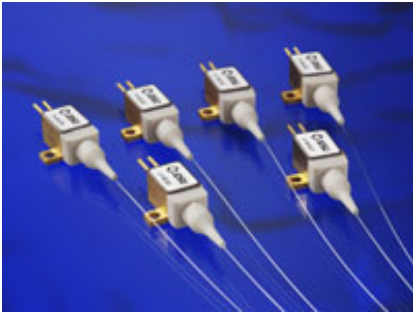

915/940 nm Fiber-Coupled Diode Lasers

L4S Series

**Key Features**

- 0.22 numerical aperture (NA) fiber: 12 W output power
- 0.15 NA fiber: 11 W output power
- High reliability
- 105 μm aperture
- 1060 nm feedback protection (L4Si)
- Isolated electrical contacts

Application

- Fiber laser pumping
- Material processing
- Graphic arts
- Medical

L4S series diode lasers offer up to 12 W of power through a 105 μm fiber. The L4S leverages the low-cost L4 platform while introducing a high-power proprietary chip, incorporating a highly-reliable design scalable into a commercial product.

The multimode pump modules offer high brightness, small footprints, and simplified thermal management by disturbing the diodes (heat sources), allowing the use of either air- or water-cooled architectures with predictable high reliability.

The L4S series is a unique solution for the fiber-coupled pump-laser market, offering powerful technical attributes in a cost-effective package.

2

Dimensions Diagram

(Specifications in mm.)

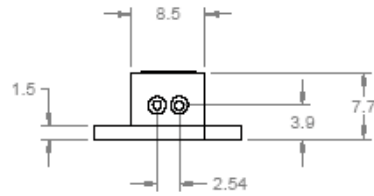
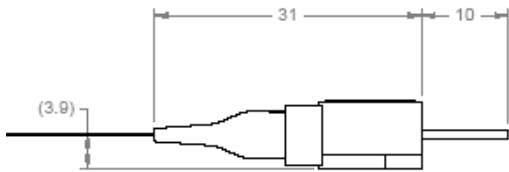
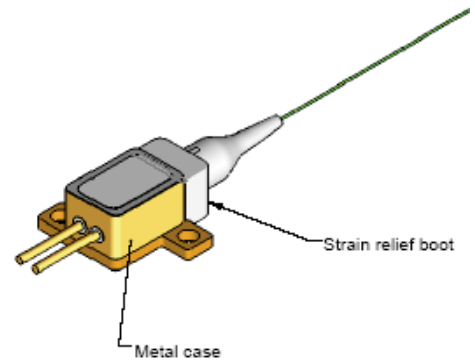
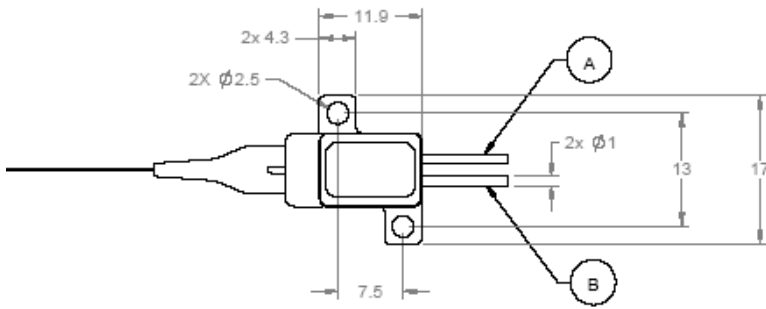

Pinout

Pin	Description
A	Laser cathode (-)
B	Laser anode (+)

3

Specifications for 0.22 NA¹

Parameter	Symbol	Minimum	Typical	Maximum
Laser Characteristics				
CW output power	P_o	—	—	12 W
Mean wavelength ²	λ_p 915 nm	905 nm	917 nm	928 nm
	λ_p 940 nm	928 nm	939 nm	950 nm
Spectral width (FWHM)	$\Delta\lambda$	—	3 nm	6 nm
Slope efficiency	η_D 915 nm	—	0.93 W/A	—
	η_D 940 nm	—	0.92 W/A	—
Conversion efficiency	η	—	46%	—
Threshold current	I_{th}	—	700 mA	950 mA
Operating current (BOL)	I_{op} 915 nm	—	13.6 A	14.6 A
	I_{op} 940 nm	—	13.8 A	15.0 A
Forward voltage	V_f	—	1.89 V	2.2 V
Series resistance	R_s	—	0.04 Ω	—
Recommended case temperature	T_c	20°C	25°C	40°C
Wavelength tuning vs. temperature ³	$\Delta\lambda/\Delta T$	—	0.35 nm/°C	—
Wavelength tuning vs. output power	$\Delta\lambda/\Delta P$	—	1.0 nm/W	—
Power in 0.17 NA		95%	—	—
Fiber Characteristics				
Fiber core diameter	d_c	102 μm	105 μm	108 μm
Fiber numerical aperture	NA	0.20	0.22	0.24
Fiber cladding	d_{cl}	—	125 μm	—
Fiber buffer	d_b	—	250 μm	—
Fiber length	l_f	0.9 m	1 m	—

1. All performance data is measured at 12 W, 25°C, beginning of life (BOL), with anti-reflective coating output.

2. Weighted average “center of mass” spectral point at 25°C at P_o .

3. Change in $\Delta\lambda$ mean with case temperature over T_{op} .

4

Specification for 0.15 NA¹

Parameter	Symbol	Minimum	Typical	Maximum
Laser Characteristics				
CW output power	P_o	—	—	11 W
Mean wavelength ²	λ_p 915 nm	905 nm	917 nm	928 nm
	λ_p 940 nm	928 nm	939 nm	950 nm
Spectral width (FWHM)	$\Delta\lambda$	—	3 nm	6 nm
Slope efficiency	η_D 915 nm	—	0.91 W/A	—
	η_D 940 nm	—	0.90 W/A	—
Conversion efficiency	η	—	46%	—
Threshold current	I_{th}	—	700 mA	950 mA
Operating current (BOL)	I_{op} 915 nm	—	13.2 A	14.4 A
	I_{op} 940 nm	—	13.6 A	14.6 A
Forward voltage	V_f	—	1.90 V	2.2 V
Series resistance	R_s	—	0.04 Ω	—
Recommended case temperature	T_c	20°C	25°C	40°C
Wavelength tuning vs. temperature ³	$\Delta\lambda/\Delta T$	—	0.35 nm/°C	—
Wavelength tuning vs. output power	$\Delta\lambda/\Delta P$	—	1.0 nm/W	—
Fiber Characteristics				
Fiber core diameter	d_c	102 μm	105 μm	108 μm
Fiber numerical aperture	NA	0.135	0.15	0.165
Fiber cladding	d_{cl}	—	125 μm	—
Fiber buffer	d_b	—	250 μm	—
Fiber length	l_f	0.9 m	1 m	—

1. All performance data is measured at 12 W, 25°C, beginning of life (BOL), with anti-reflective coating output.

2. Weighted average “center of mass” spectral point at 25°C at P_o .

3. Change in $\Delta\lambda$ mean with case temperature over T_{op} .

Fiber Laser Feedback Isolation Specifications for –120E and –120F Options

Wavelength range	Isolation	Reflectivity
1060 – 1100 nm	>30 dB	>99.9%
1050 – 1150 nm	>25 dB	>99.7%

5

Absolute Maximum Ratings

Parameter	Symbol	Minimum	Typical	Maximum
Operating current	I_{op}	—	—	17 A
Reverse voltage	V_{rvs}	—	—	2.0 V
Case operating temperature ⁴	T_{op}	15°C	—	50°C
Storage temperature ⁵	T_{stg}	−30°C	—	70°C
Lead soldering temperature, 10 s max	T_{ls}	—	—	300°C
Relative humidity, non-condensing, ambient < 45°C	RH	—	—	85%
Electrostatic discharge (ESD) ⁶	V_{esd}	—	—	500 V
Fiber bend radius (long term deployment) ⁷		30 mm	—	—
Fiber axial pull force, 15 s		—	—	5 N
Fiber side pull force, 15 s		—	—	2.5 N

4. Non-condensing, maximum

5. Non-condensing, 2000 hours

6. C = 100 pF, R = 1.5 kΩ, human body model, shown to be not damaging to its LI characteristics or its reliability, I-V curves may change in this ESD environment.

7. Minimum bend radius of 30 mm is for long-term mechanical fiber reliability; however, for 0.15 NA, some optical loss may occur and a minimum bend radius of 45 mm is recommended for layout with multiple fiber coils.

Ordering Information

For more information on this or other products and their availability, please contact your local JDSU account manager or JDSU directly at 1-800-498-JDSU (5378) in North America and +800-5378-JDSU worldwide or via e-mail at customer.service@jdsu.com.

Sample: 21176737

Part Number	Product Code	Wavelength Range	Connector	Fiber NA	Feedback Protection
21176737	L4S-91510-120B	905 – 928 nm	No	0.22	No
21176738	L4S-91510-120C	905 – 928 nm	No	0.15	No
21176739	L4S-91510-120E	905 – 928 nm	No	0.22	Yes
21176740	L4S-91510-120F	905 – 928 nm	No	0.15	Yes
22012885	L4S-94010-120B	928 – 950 nm	No	0.22	No
22012886	L4S-94010-120C	928 – 950 nm	No	0.15	No
22012887	L4S-94010-120E	928 – 950 nm	No	0.22	Yes
22012888	L4S-94010-120F	928 – 950 nm	No	0.15	Yes

6

Operating Considerations

Operating the diode laser outside at maximum ratings may cause device failure or a safety hazard. Power supplies used with the component must be employed so that the maximum peak optical power cannot be exceeded. CW diode lasers may be damaged by excessive drive current or switching transients. When power supplies are used, the diode laser should be connected with the main power on and the output voltage at zero. The current should be increased slowly while the diode laser output power and the drive current are monitored.

Device degradation accelerates with increased temperature, and thus the case temperature should be minimized.

A proper heatsink for the diode laser on a thermal radiator will greatly enhance laser life. Refer to the product application note for more information regarding heat sinking and mounting the product.

Electrostatic Discharge (ESD) Protection

ESD is the primary cause of unexpected diode-laser failure. Take extreme precaution to prevent ESD. Use wrist straps, grounded work surfaces, and rigorous antistatic techniques when handling diode lasers.

Laser Safety
DANGER

Invisible laser radiation. The laser beam emitted from this diode laser is invisible and can cause serious injury.

Avoid looking directly into the diode laser or the collimated laser beam along its optical axis when the device is in operation.

Avoid reflected or scatter radiation.

Use protective eyewear properly selected for the laser beam wavelength and maximum power.

Viewing the laser output with certain optical instruments (e.g., eye loupes, magnifiers, and microscopes) will increase eye hazards.

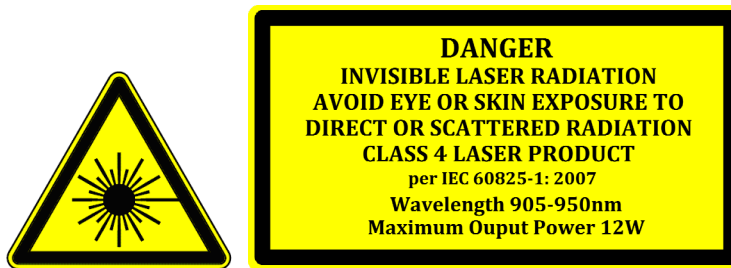
Labeling

This diode pumped laser module is not 21CFR 1040.10 or IEC 60825-1:2007 certified. It is a component intended for system integration. Compliance with 21CFR 1040.10 and/or IEC 60825-1:2007 will need to be determined at the system level.

Serial Number Identification Label
