

## Cable connector - CA-12F2N8A85DUS - 1619474

Please be informed that the data shown in this PDF Document is generated from our Online Catalog. Please find the complete data in the user's documentation. Our General Terms of Use for Downloads are valid (<http://phoenixcontact.com/download>)



Cable connector, CA, straight, shielded: yes, SPEEDCON locking, M23, No. of pos.: 12, type of contact: Socket, Crimp connection, cable diameter range: 3 mm ... 14.5 mm

### Your advantages

- ✓ Safe use in the field, thanks to high degree of protection
- ✓ Connector for flexible on-site assembly
- ✓ Consistent EMC protection for reliable connection solutions in the industrial environment
- ✓ Reduced connection time with SPEEDCON fast locking system
- ✓ Crimping connection: vibration- and temperature-resistant assembly



### Key Commercial Data

Packing unit	1 pc
GTIN	 4 046356 823739
GTIN	4046356823739
Weight per Piece (excluding packing)	100.000 g
Custom tariff number	85366990
Country of origin	Germany

### Technical data

#### Temperature range

Ambient temperature (operation)	-40 °C ... 125 °C
---------------------------------	-------------------

#### Data of the insulating body

Note	Order information: Order crimp contacts Ø 1 mm separately
Coding	N

## Cable connector - CA-12F2N8A85DUS - 1619474

### Technical data

#### Data of the insulating body

Insulator material	PA 6.6
Contact connection method	Crimp connection
Type of contacts	Socket
Application	Feedback, signal
Number of positions	12
Contact diameter of power contacts	1 mm
Nominal current per power contact at 25°C	8 A
Nominal voltage, power contact	150 V
Rated surge voltage	2.5 kV
Overvoltage category	III
Degree of pollution	3
Overvoltage category	III
Degree of pollution	3

#### Housing data

Housing material	Metal
Type of locking	SPEEDCON locking
Degree of protection (when plugged in)	IP67
Thread type	M23

#### Cable seal data

Cable diameter	3 mm ... 14.5 mm
Sealing material	FPM

#### Environmental Product Compliance

	Lead 7439-92-1
China RoHS	Environmentally Friendly Use Period = 50
	For details about hazardous substances go to tab "Downloads", Category "Manufacturer's declaration"

### Drawings

# Cable connector - CA-12F2N8A85DUS - 1619474

Dimensional drawing

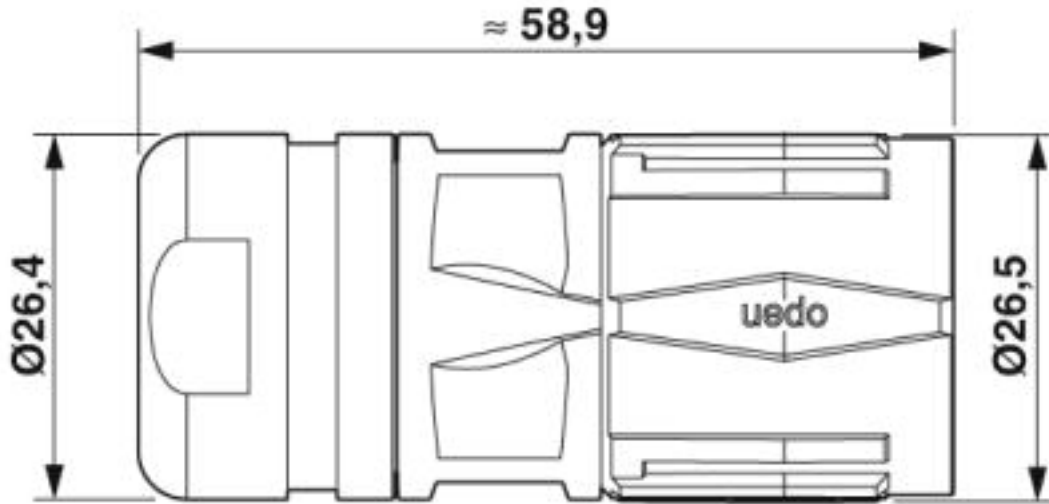

## Cable connector - CA-12F2N8A85DUS - 1619474

Schematic diagram



Contact chamber numbering (view of plug-in side), socket counter direction

### Classifications

eCl@ss

eCl@ss 4.0	27260700
eCl@ss 4.1	27260700
eCl@ss 5.0	27260700
eCl@ss 5.1	27260700
eCl@ss 6.0	27260700

# Cable connector - CA-12F2N8A85DUS - 1619474

## Classifications

### eCl@ss

eCl@ss 7.0	27440102
eCl@ss 8.0	27440102
eCl@ss 9.0	27440103

### ETIM

ETIM 3.0	EC001121
ETIM 4.0	EC002635
ETIM 5.0	EC002635
ETIM 6.0	EC002061

### UNSPSC

UNSPSC 6.01	43172015
UNSPSC 7.0901	43201404
UNSPSC 11	43172015
UNSPSC 12.01	43201404
UNSPSC 13.2	39121413

## Approvals

### Approvals

#### Approvals

UL Recognized / cUL Recognized / EAC / cULus Recognized

#### Ex Approvals

### Approval details

UL Recognized		<a href="http://database.ul.com/cgi-bin/XYV/template/LISEXT/1FRAME/index.htm">http://database.ul.com/cgi-bin/XYV/template/LISEXT/1FRAME/index.htm</a>	E335019-20141210
Nominal voltage UN	150 V		
Nominal current IN	8 A		
mm <sup>2</sup> /AWG/kcmil	18		

## Cable connector - CA-12F2N8A85DUS - 1619474

### Approvals

cUL Recognized		<a href="http://database.ul.com/cgi-bin/XYV/template/LISEXT/1FRAME/index.htm">http://database.ul.com/cgi-bin/XYV/template/LISEXT/1FRAME/index.htm</a>	E335019-20141210
Nominal voltage UN		150 V	
Nominal current IN		6 A	
mm <sup>2</sup> /AWG/kcmil		18	

EAC		B.01742
-----	--	---------

cULus Recognized	
------------------	--

### Accessories

#### Accessories

#### Crimp contact

Crimp contact - SF-6CS2000 - 1605562



Crimp contact, turned, Single contact, contact diameter: 1 mm, crimp range: 0.06 mm<sup>2</sup> ... 0.25 mm<sup>2</sup>

Crimp contact - SF-10KS004 - 1607356



Crimp contact, turned, Single contact, contact diameter: 1 mm, crimp range: 0.14 mm<sup>2</sup> ... 0.5 mm<sup>2</sup>

## Cable connector - CA-12F2N8A85DUS - 1619474

### Accessories

Crimp contact - SF-6AS2000 - 1605557



Crimp contact, turned, Single contact, contact diameter: 1 mm, crimp range: 0.25 mm<sup>2</sup> ... 1 mm<sup>2</sup>

---

### Mounting material

Color-coding - RF-Z0014 - 1620588



Color-coding, color: green

---

Color-coding - RF-Z0015 - 1620592



Color-coding, color: orange

---

Color-coding - RF-Z0016 - 1620593



Color-coding, color: black

---

Torque screwdriver - SF-Z0028 - 1607456



Torque screwdriver

---

## Cable connector - CA-12F2N8A85DUS - 1619474

### Accessories

Square mounting flange - RF-Z0003 - 1607905



Square mounting flange, Axial seal, 4xM3, flange dimensions: 35 mm x 35 mm

---

### Protective cover

Protective cap - RC-Z2058 - 1604223



Plastic protection cap for connectors with M23 knurled nut

---

Plastic anti-static dust protection cap - RC-Z2468 - 1611796



Plastic protection cap, antistatic, for connectors with M23 knurled nut

---

Hook wrench - SF-Z0027 - 1607455



Hook wrench

---