

PRELIMINARY

# MITSUBISHI DIGITAL TV ICs M65669SP/FP

Notice ; This is not the final specification.  
Some of information in this document are  
subject to changes.

**V3.1**

PICTURE-IN-PICTURE  
SIGNAL PROCESSING

## DESCRIPTION

The M65669SP/FP is a PIP (Picture in Picture) signal processing LSI, whose sub-picture input is composite signal for NTSC, PAL-M, and PAL-N. The built-in field memory (144k-bit RAM) , V-chip data slicer and analog circuitries lead the high quality PIP system low cost and small size.

## FEATURES

- \* Built-in 144k-bit field memory ( sub-picture data storage)
- \* Internal V-chip data slicer (for sub-picture)
- \* Vertical filter for sub-picture ( Y signal )
- \* Single sub-picture ( selectable picture size : 1/9 , 1/16 )
- \* Sub-picture processing specification ( 1/9 , 1/16 size ) :
  - Quantization bits Y, B-Y, R-Y : 6 bits
  - Horizontal sampling 229 pixels ( Y ) , 57 pixels ( B-Y, R-Y )
  - Vertical lines 69/ 52 lines
- \* Frame ( sub-picture ) on/off
- \* Built-in analog circuits :
  - One 8-bit A/D converter ( for sub-picture signal)
  - Three 8-bit D/A converters ( for Y, U and V of sub-picture )
  - Sync-tip-clamp, VCXO ... etc..
- \* IIC BUS control ( parallel/serial control ) :
  - PIP on/off , Frame on/off ( programmable luma level),
  - Sub-picture size ( 1/9, 1/16 ) ,
  - PIP position ( free position ) , Picture freeze ,
  - Y delay adjustment, Chroma level, Tint, Black level,
  - Contrast ...etc..

## APPLICATION

NTSC, PAL-M, PAL-N color TV

## RECOMMENDED OPERATING CONDITIONS

Supply voltage range	-----	3.1 ~ 3.5 V
Operating frequency	-----	14.32 MHz
Operating temperature	-----	-10 ~ 70 deg.
Input voltage (CMOS interface)	"H" -----	VDD x 0.7 ~ VDD V
	"L" -----	0 ~ VDD x 0.3 V
Output current ( output buffer )	-----	4 mA ( MAX )
Output load capacitance	-----	20 pF ( MAX ) *1
Circuit current	-----	mA

NOTICE: Connect a 0.1µF or larger capacitor between VDD and VSS pins.  
\*1 : Include pin capacitance ( 7 pF )

Block diagram & Application examples  
Shown next pages

## PIN CONFIGURATION (TOP VIEW)

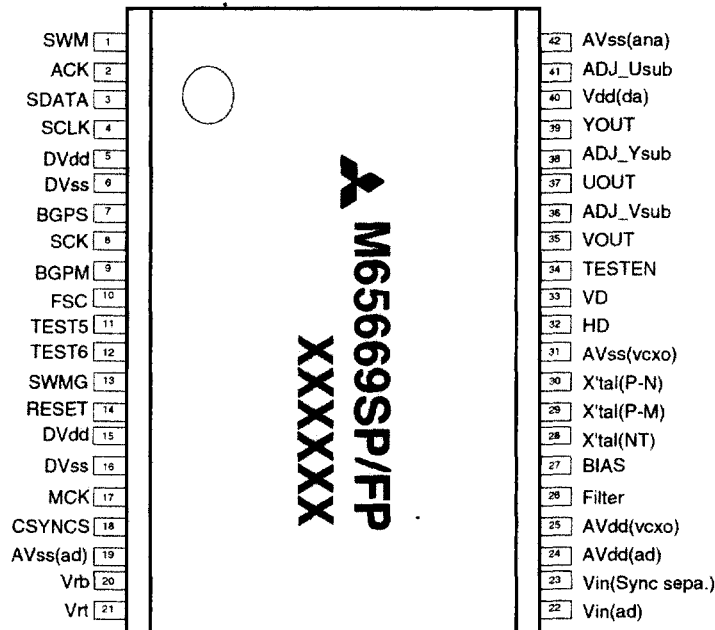

Outline 42 Pin SDIP Package (M65669SP)

Outline 0.8mm pitch 42 Pin SOP Package (M65669FP)



PRELIMINARY

# MITSUBISHI DIGITAL TV ICs M65669SP/FP

Notice ; This is not the final specification.  
Some of information in this document are  
subject to changes.

**V3.1**

PICTURE-IN-PICTURE  
SIGNAL PROCESSING

## ABSOLUTE MAXIMUM RATINGS

(V<sub>SS</sub>=0V)

Symbol	Parameter	Conditions	Limits		Unit
			Min.	Max.	
V <sub>DD3</sub>	Supply voltage (3.3V)		-0.3	4.6	V
V <sub>i</sub>	Input voltage		-0.3	V <sub>DD3</sub> +0.3	V
V <sub>o</sub>	Output voltage		-0.3	V <sub>DD3</sub> +0.3	V
I <sub>o</sub>	Output current (*1)		I <sub>OH</sub> = -4	I <sub>OL</sub> = 4	mA
P <sub>D</sub>	Power dissipation		-	1200	mW
T <sub>opr</sub>	Operating temperature		-10	70	deg.
T <sub>stg</sub>	Storage temperature		-50	125	deg.

(\*1) Output current per output terminal. But P<sub>D</sub> limits all current.

## TYPICAL CHARACTERISTICS

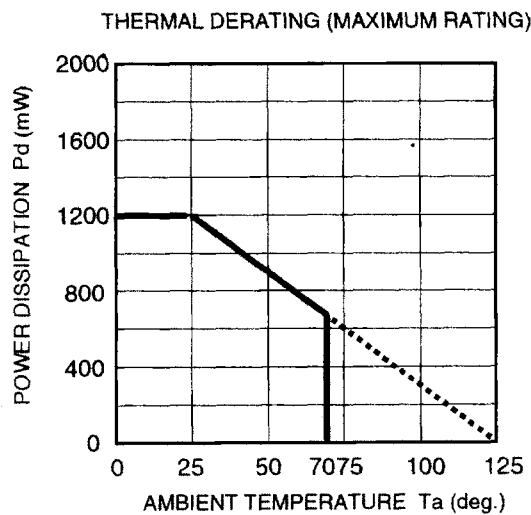

PRELIMINARY

MITSUBISHI DIGITAL TV ICs  
M65669SP/FP

Notice ; This is not the final specification.  
Some of information in this document are  
subject to changes.

**V3.1**

PICTURE-IN-PICTURE  
SIGNAL PROCESSING

DC CHARACTERISTICS

(Ta = 25 deg. unless otherwise noted)

(Vss=0V)

Symbol	Parameter		Condition	Limits			Unit
				Min.	Typ.	Max.	
V <sub>IL</sub>	Input voltage (CMOS interface)	L	V <sub>DD</sub> = 2.7V	0	-	0.81	V
V <sub>IH</sub>		H	V <sub>DD</sub> = 3.6V	2.52	-	3.6	
V <sub>T-</sub>	Input voltage schmitt trigger (CMOS interface)	-	V <sub>DD</sub> = 3.3V	0.5	-	1.65	V
V <sub>T+</sub>		+		1.4	-	2.4	
V <sub>H</sub>		Hysteresis		0.3	-	1.2	
V <sub>OL</sub>	CMOS output voltage	L	V <sub>DD</sub> = 3.3V,  I <sub>o</sub>   = 1μA	-	-	0.05	V
V <sub>OH</sub>		H		3.25	-	-	
I <sub>OL</sub>	CMOS output current	L	V <sub>DD</sub> = 3.0V, V <sub>OL</sub> = 0.4V	4	-	-	mA
I <sub>OH</sub>		H	V <sub>DD</sub> = 3.0V, V <sub>OH</sub> = 2.6V	-	-	-4	
I <sub>IH</sub>	Input current	L	V <sub>DD</sub> = 3.6V, V <sub>i</sub> = 0V	-1	-	1	μA
I <sub>IL</sub>		H	V <sub>DD</sub> = 3.6V, V <sub>i</sub> = 3.6V	-1	-	1	
I <sub>oZL</sub>	Output leakage current	L	V <sub>DD</sub> = 3.6V, V <sub>o</sub> = 0V	-1	-	1	μA
I <sub>oZH</sub>		H	V <sub>DD</sub> = 3.6V, V <sub>o</sub> = 3.6V	-1	-	1	
C <sub>i</sub>	Input pin capacitance	f = 1MHz, V <sub>DD</sub> = 0V		-	7	15	pF
C <sub>o</sub>	Output pin capacitance			-	7	15	
C <sub>io</sub>	Bidirectional pin capacitance			-	7	15	
I <sub>DD</sub>	Operating current	3.3V supply		-	180	-	mA

PRELIMINARY

MITSUBISHI DIGITAL TV ICs  
M65669SP/FP

Notice ; This is not the final specification.  
Some of information in this document are  
subject to changes.

V3.1

PICTURE-IN-PICTURE  
SIGNAL PROCESSING

PIN DESCRIPTION

Pin No.	Name	I/O	Function	Remarks
1	SWM	CMOS output	PIP switch output	
2	ACK	CMOS output	I2C SDA output (for high load SDA line use only)	
3	SDATA	CMOS I/O (5V)*1	I2C SDA input/output	
4	SCLK	CMOS input (5V)*1	I2C SCL input	
5	DVdd1	Digital Vdd	Vdd for digital part	
6	DVss1	Digital Vss	Vss for digital part	
7	BGPS	CMOS output	Test output	
8	SCK	CMOS input	Test input	connect to GND
9	BGPM	CMOS output	Test output	
10	FSC	CMOS input	Test input	connect to GND
11	TEST5	CMOS input	Test input	connect to GND
12	TEST6	CMOS input	Test input	connect to GND
13	SWMG	CMOS input		connect to Vdd
14	RESET	CMOS input	Power on reset input	
15	DVdd2	Digital Vdd	Vdd for digital part	
16	DVss2	Digital Vss	Vss for digital part	
17	MCK	CMOS input	Test input	connect to GND
18	CSYNCS	CMOS input	Sub picture external C-sync input	
19	AVss (ADC)	Analog Vss	Vss for internal ADC	
20	VRB	Analog	Low level reference voltage output of ADC	
21	VRT	Analog	High level reference voltage output of ADC	
22	VIN (ADC)	Analog	Sub picture input of ADC	
23	VIN (Sync Sep.)	Analog	Sub picture input of sync sep. for sub picture	
24	AVdd (ADC)	Analog Vdd	Vdd for internal ADC	
25	AVdd (VCXO)	Analog Vdd	Vdd for VCXO	
26	FILTER	Analog	VCXO filter voltage connection	
27	BIAS	Analog	VXCO bias voltage connection	
28	X'tal (NTSC)	Analog	X'tal of NTSC connection	
29	X'tal (PAL-M)	Analog	X'tal of PAL-M connection	
30	X'tal (PAL-N)	Analog	X'tal of PAL-N connection	
31	AVss (VCXO)	Analog Vss	Vss for VCXO	
32	HD	CMOS input (5V)*1	Main picture HD input	
33	VD	CMOS input (5V)*1	MAIN picture VD input	
34	TESTEN	CMOS input	Test input	connect to GND
35	VOUT	Analog	Sub picture V or B output	
36	ADJ_Vsub	Analog	Referece voltage connection of DAC of V	
37	UOUT	Analog	Sub picture U or G output	
38	ADJ_Ysub	Analog	Referece voltage connection of DAC of Y	
39	YOUT	Analog	Sub picture Y or R output	
40	AVdd (DAC)	Analog Vdd	Vdd for DAC	
41	ADJ_Usub	Analog	Referece voltage connection of DAC of U	
42	AVss (sub)	Analog Vss	Vss for substrate	

\*1 ) (5V)means 5V I/F torelant

PRELIMINARY

# MITSUBISHI DIGITAL TV ICs M65669SP/FP

Notice ; This is not the final specification.  
Some of information in this document are  
subject to changes.

V3.1

PICTURE-IN-PICTURE  
SIGNAL PROCESSING

## BASIC APPLICATION EXAMPLE

< NTSC only application example >

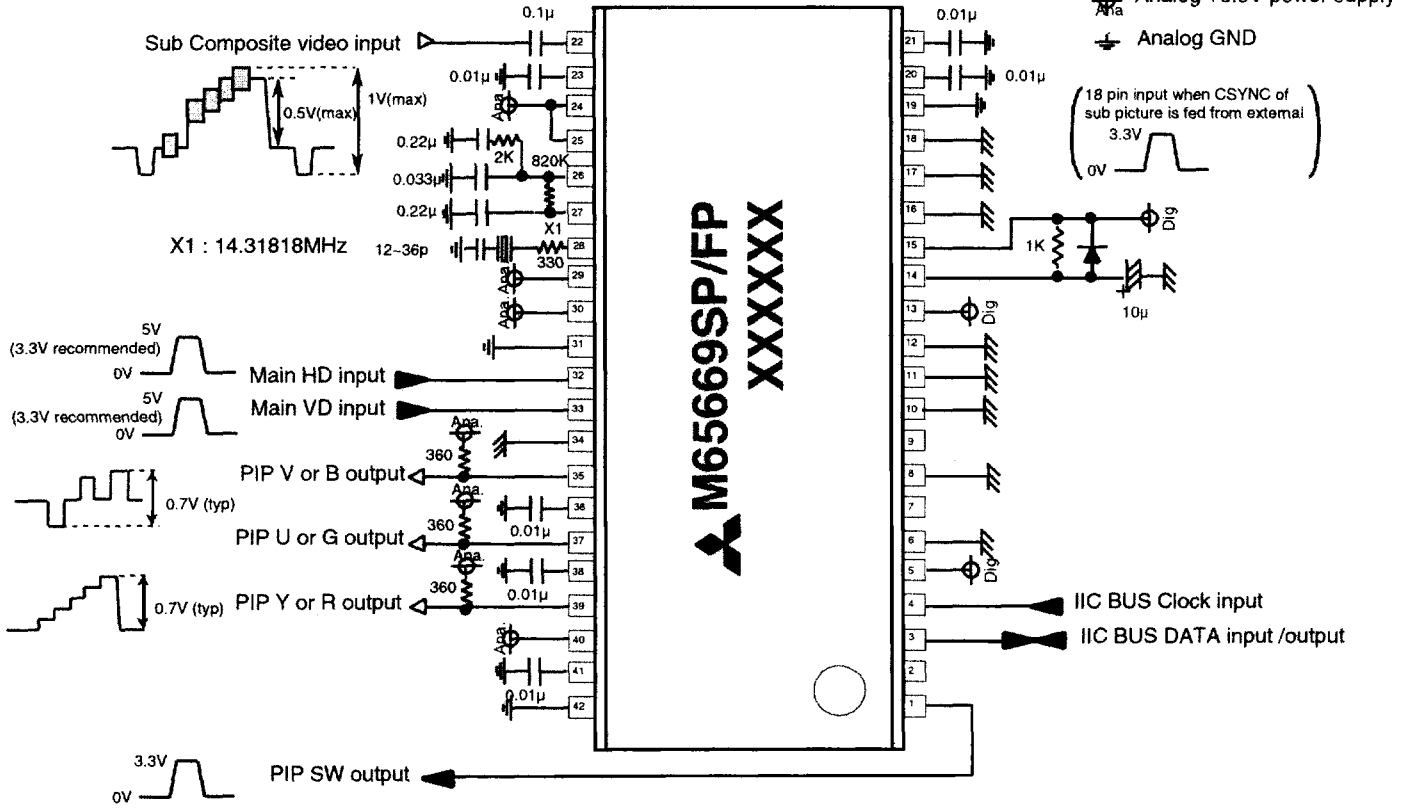

< NTSC / PAL-M / PAL-N application example >

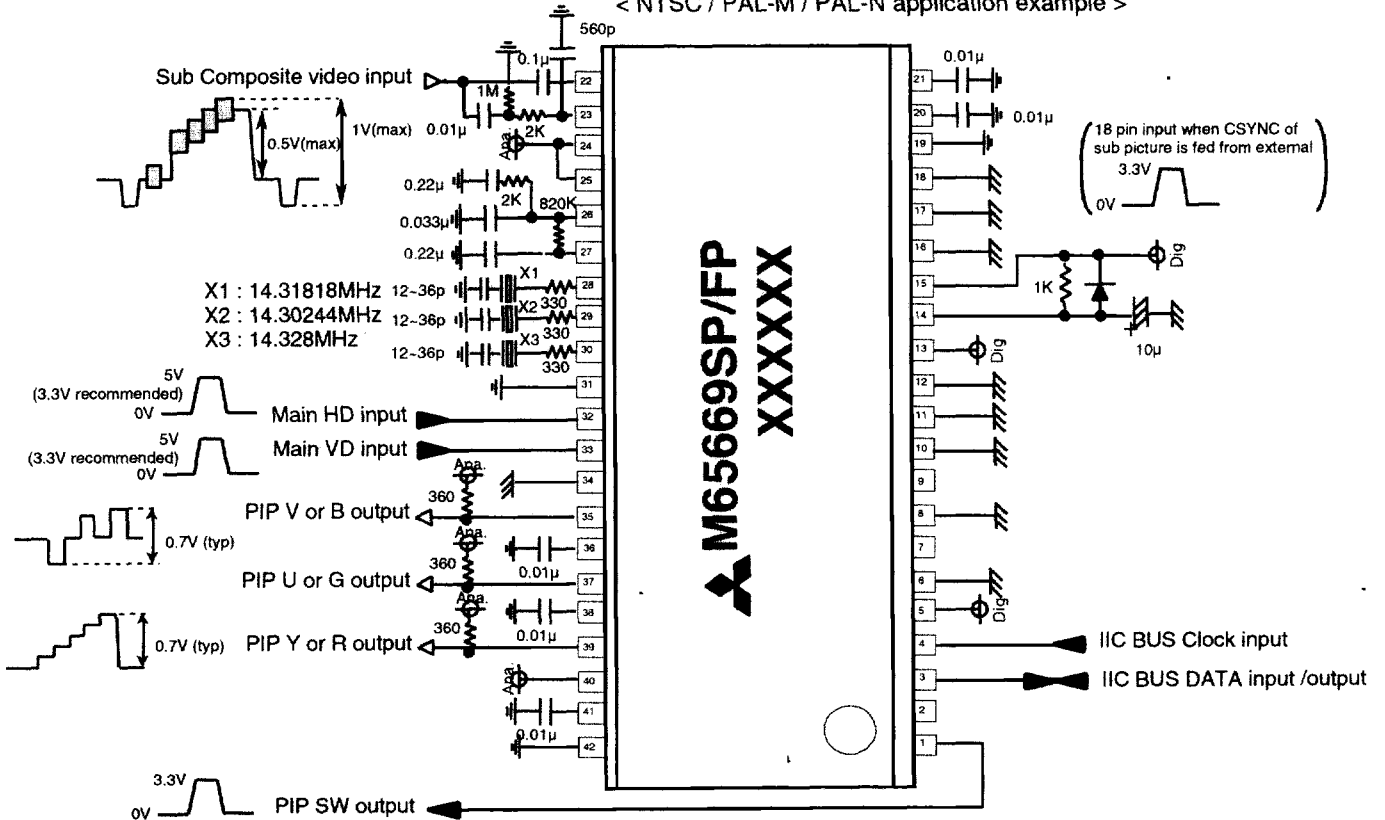

PRELIMINARY

# MITSUBISHI DIGITAL TV ICs M65669SP/FP

Notice ; This is not the final specification.  
Some of information in this document are  
subject to changes.

**V3.1**

PICTURE-IN-PICTURE  
SIGNAL PROCESSING

## M65662FP TV SYSTEM BLOCK DIAGRAM

<BASIC >

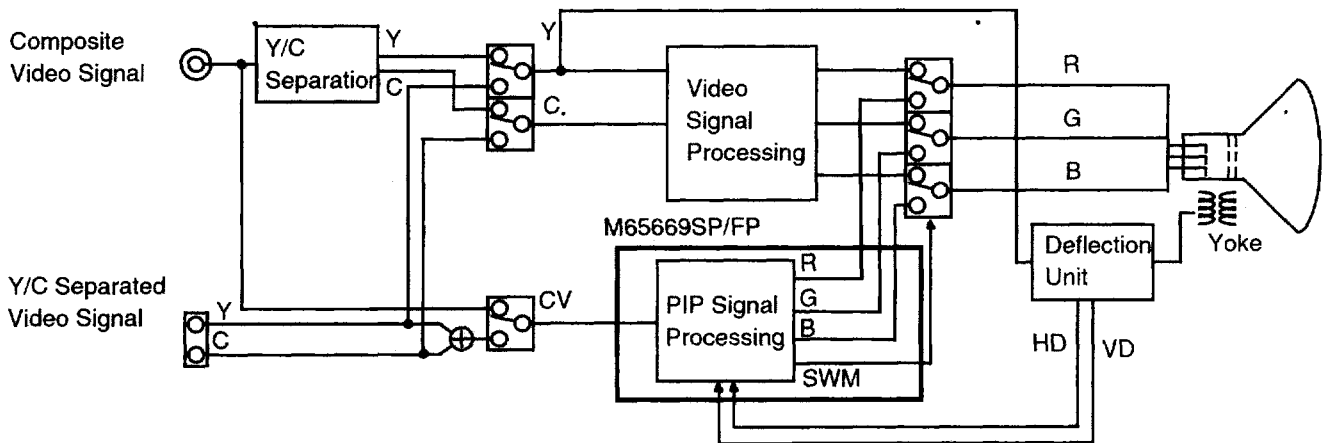
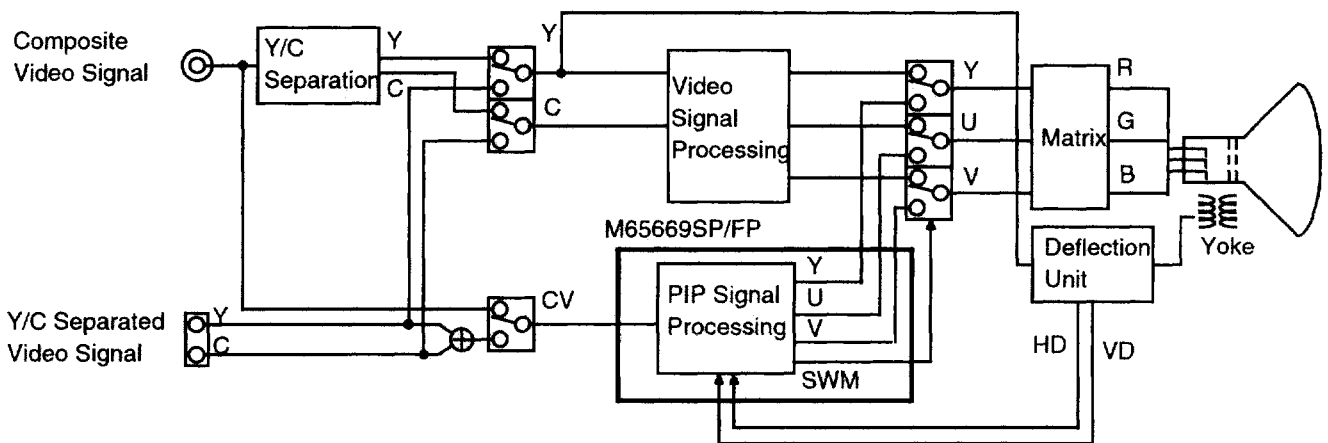

PRELIMINARY

MITSUBISHI DIGITAL TV ICs  
M65669SP/FP

Notice ; This is not the final specification.  
Some of information in this document are  
subject to changes.

V3.1

PICTURE-IN-PICTURE  
SIGNAL PROCESSING

Internal register information (preliminary)

address	bit	symbol	Reset val	1/9 ex.	remarks
00h	<7>	DISP	0	1	Sub picture display : [0] off, [1] on
	<6>	SIZE_V	0	0	Sub picture vertical size : [0] 1/9, [1] 1/16
	<5>	SIZE_H	0	0	Sub picture horizontal size : [0] 1/9, [1] 1/16
	<4>	WEN	0	1	Sub picture : [0] Still, [1] Moving
	<3>	BGC	0	0	Back ground display : [0] off, [1] on
	<2>	BGCS	0	0	Sub picture mute : [0] off, [1] on
	<1>	FREE_RUN	1	0	VCXO oscilation : [0] Lock, [1] Free run
	<0>	RVS	0	0	HD / VD input synchronous mode selection : [0] sync., [1] async.
01h	<7:0>	VXA<7:0>	FFh	20h	Sub picture vertical position
02h	<7:0>	HXA<7:0>	FFh	20h	Sub picture horizontal position
03h	<7>	DECODE	0	0	Sub picture color decoder reset : [1] reset
	<6:0>	CONTRAST<6:0>	33h	32h	Sub picture Y or R DAC output amplitude control
04h	<7>	KILLER	0	0	Sub picture color killer : [0] enable, [1] disable
	<6:0>	U_DAC<6:0>	33h	32h	Sub picture U or G DAC output amplitude control
05h	<7>	GRC	1	1	Frame display : [0] off, [1] on
	<6>	YUVN_RGB_SEL	0	0	PIP output mode selection : [0] YUV, [1] RGB
	<5:0>	TINT<5:0>	00h	00h	Sub picture tint control
06h	<7:6>	EXT_SC_SEL<1:0>	0h	0h	Sub picture C-Sync sep. input selection : [0] Digital, [1] 23 pin input, [2] external (18 pin input), [3] Int. analog
	<5:4>	DCONT<1:0>	0	0	Sub picture digital sync sep.threshold setting
	<3:0>	HT<3:0>	3h	Ah	Sub picture display timing adjust
07h	<7:6>	EXPORT<1:0>	2h	2h	Ext. port setting (7 pin) : [0or1] Sub BGP, [2]"0" output, [3]"1" output
	<5:0>	BG_START<5:0>	0Eh	0Eh	Sub picture BGP position setting
08h	<7:4>	ADJ<3:0>	2h	2h	Main/Sub switch delay control
	<3:0>	YDL<3:0>	7h	Fh	Sub picture Y/C delay adjust
09h	<7:5>	BGBY<2:0>	0h	0h	Back ground U level setting
	<4:0>	Y_OFFSET<4:0>	0Fh	0Fh	Sub picture Y bright control
0Ah	<7>	VCHIP_ONLY	0	0	V-chip decode mode : [0] off, [1] on
	<6:4>	BGRY<2:0>	0h	0h	Back ground V level setting
	<3:0>	BGY<3:0>	Ch	Ch	Back ground Y level setting
0Bh	<7:4>	PEDESTV<3:0>	0h	0h	Sub picture V pedestal level (2's comp)
	<3:0>	PEDESTU<3:0>	0h	0h	Sub picture U pedestal level (2's comp)
0Ch	<7>	UV_FILTER_OFF	0	0	Sub picture U, V output filter : [0]on, [1]off
	<6>	SET_ACC	0	0	Address 0Dh, 0Eh setting mode : [0]default, [1] enable to set
	<5:4>	SYSTEM_MODE<1:0>	0h	0h	System : [0]NTSC, [1]PAL-M, [2]PAL-N, [3] N.A.
	<3>	SET_SIZE	0	0	Address 11h, 12h, 13h, 14h setting mode : [0]default, [1] enable to set
	<2>	SET_VCHIP	0	0	Address 15h, 16h, 17h setting mode : [0]default, [1] enable to set
	<1>	INV_UV	0	0	Invert U, V output value : [0] normal, [1] invert
	<0>	CROSS_SEL	0	0	Sub picture read mode : [0] pixel based, [1] H based
0Dh	<7:6>	SYNC_DELAY<1:0>	0h		Sub picture sync.delay control
	<5:4>	MVP_SEL<1:0>	0h		Sub picture decoder macro vision mode selection
	<3>	C_GAIN_SEL	0		Sub picture chroma : [0] x1, [1] x2
	<2:0>	INVLEVEL<2:0>	0h		Sub picture decoder macro vision mode threshold
0Eh	<7>	BITSEL	0		Sub picture Y clamp time constant : [0] x2, [1] x1
	<6>	AFCBITSEL	0		Sub picture AFC time constant : [0] x2, [1] x1
	<5:0>	ACC_LEVEL<5:0>	15h		Sub picture color decoder amplitude
0Fh	<7>	AUTO_ENABLE	0		System automatic judgment : [0] off, [1] on
	<6>	BURST_CLOCK_MODE	0		VCXO mode selection : [0] 1H based, [1] 2H based
	<5>	PALN_ENABLE	0		Main picture PAL-N : [0] enable, [1] disable
	<4>	INV_WFF	0		Invert sub picture field definition : [0] normal, [1] invert
	<3>	INV_RFF	0		Invert main picture field definition : [0] normal, [1] invert
	<2>	ERRSEL	0		for test : 0 set only
	<1>	RFF_FIX	0		Main picture field fix : [0] not fix, [1]fix
	<0>	AUTO_RFF_FIX	0		Automatic 50/60Hz Judgement : [0] enable, [1] disable

PRELIMINARY

MITSUBISHI DIGITAL TV ICs  
M65669SP/FP

Notice ; This is not the final specification.  
Some of information in this document are  
subject to changes.

V3.1

PICTURE-IN-PICTURE  
SIGNAL PROCESSING

Internal register information (continuing) (preliminary)

address	bit	symbol	Reset val	1/9 ex.	remarks
10h	<7>	INVDECODE	0	0	Sub picture decoder mode : [0] NTSC, [1] PAL
	<6>	AVERAGE	0	0	Sub picture decoder mode : [0] 1H based, [1] 2H based
	<5:0>	PALRY<5:0>	00h	00h	Threshold control of ident judgment of sub picture decoder
11h	<7>	WDOF_KILLER_ON	0		Sub picture killer on when its vert. sync lost : [0] on, [1] off
	<6:0>	HYA<6:0>	37h		Sub picture horizontal display pixel
12h	<7:0>	VYA<7:0>	44h		Sub picture vertical display line number
13h	<7:2>	HX<5:0>	1Eh		Sub picture horizontal capture position (coarse)
	<1:0>	HP<1:0>	0h		Sub picture horizontal capture position (fine)
14h	<7:6>	MVC<1:0>	0h		Sub picture C-sync input mask period : 0] 48us, [1] 44us, [2] 53us, [3] off
	<5:0>	VXS<5:0>	29h		Sub picture sample start line
15h	<7>	-	0		for test : 0 set only
	<6>	PLUS	0		for test : 0 set only
	<5>	-	0		for test : 0 set only
	<4:0>	LINE_NUM<4:0>	11h		Data slicer line selection
16h	<7:0>	STB_DLY<7:0>	40h		Data slicer start bit detection parameter
17h	<7:0>	L_LEVEL<7:0>	82h		Data slicer data slice parameter
18h	<7>	EDGE_ON	0		Frame data independent control : [0] disable, [1] enable
	<6:4>	BGBY_EDGE<2:0>	0h		Frame data independent B-Y data setting
	<3:0>	BGY_EDGE<3:0>	Ch		Frame data independent Y data setting
19h	<7:5>	BGRY_EDGE<2:0>	0h		Frame data independent R-Y data setting
	<4>	HPFOFF	0		Sub picture Y output HPF : [0]on, [1]off
	<3:0>	FREE_RUN_ADJ<3:0>	0h		Frequency adjustment control when free run mode (2's comp)
1Ah	<7:0>	SUB_PALM_JDGE<7:0>	0h		Parameter setting for PAL-M judgment
1Bh	<7:6>	NO_BST_LEVEL	0h		for test
	<5:4>	BW_DET_LEVEL	0h		for test
	<3:0>	HADJ<3:0>	0h		Parameter setting for PAL-M judgment
1Ch	<7>	PINOE	0		for test
	<6:0>	V_DAC<6:0>	0h		Sub picture V or B DAC output amplitude control
1Dh	<7:0>	PINOE<7:0>	FFh		for test
1Eh	<7:0>	-			No assignment
1Fh	<7:6>	SYSTEM_STATE<1:0>			System state : [0] NTSC, [1] PAL-M, [2] PAL-N, [3]N.A. (Read only)
	<5>	MAIN_PALN			Main is : [0] not PAL-N, [1] PAL-N (Read only)
	<4>	SUB_UNLOCK			VCXO is : [0] Lock, [1] Unlock (Read only)
	<3>	SUB_PALN			Sub is : [0] not PAL-N, [1] PAL-N (Read only)
	<2>	RDOF			Main picture vertical sync is : [0] present, [1] not present (Head only)
	<1>	MAIN_BW			Test use (Head only)
	<0>	WDOF			Sub picture vertical sync is : [0] present, [1] not present (Read only)
20h	<7:6>	NOISE<1:0>			Test use (Read only)
	<5>	WDOF			Sub picture vertical sync detection (Read only)
	<4>	EDS_ACK2			EDS data flag of even field : [0] no EDS, [1] EDS (Read only)
	<3>	EDS_ACK1			EDS data flag of odd field : [0] no EDS, [1] EDS (Read only)
	<2>	SIGNAL_OK			Test use (Read only)
	<1>	READ_REQB			Read request of even field : [0] no, [1] requesting (Read only)
	<0>	READ_REQA			Read request of odd field : [0] no, [1] requesting (Read only)
21h	<7:0>	PDB<15:8>			Even field Sliced data upper 8 bit (Read only)
22h	<7:0>	PDB<7:0>			Even field Sliced data lower 8 bit (Read only)
23h	<7:0>	PDA<15:8>			Odd field Sliced data upper 8 bit (Read only)
24h	<7:0>	PDA<7:0>			Odd field Sliced data lower 8 bit (Read only)

Notice ; This is not the final specification.  
Some of information in this document are  
subject to changes.

V3.1

PICTURE-IN-PICTURE  
SIGNAL PROCESSING

---

#### <Driving Method and Operating Specification for Serial Interface Data>

##### (1) Serial data transmission completion and start

A low-to-high transition of the DATA (serial data) line while the CLK (serial clock) is high, that completes the serial transmission and makes the bus free.

A high-to-low transition of the DATA line while the CLK is high, that starts the serial transmission and waits for the following CLK and DATA inputs.

##### (2) Serial data transmission

The data are transmitted in the most significant bit (MSB) first by one-byte unit on the DATA line successively. One-byte data transmission is completed by 9 clock cycles, the former 8 cycles are for address/data and the latter one is for acknowledge detection. (In reading state, ACK is 'H' under these two conditions ; 1) the coincidence of two address data for the address data transmission, 2) the completion of 8-bit setting data transfer. In writing state, ACK is 'H' with the address coincidence and ACK is 'L' for detecting acknowledge input from the master (micro processor) after sending 8-bit setting data.)

For address/data transmission, DATA must change while CLK is 'L'. (The data change while CLK is 'H' or the simultaneous change of CLK and DATA, that will be a false operation because of undistinguished condition from the completion/start of serial data transfer).

After the beginning of serial data transmission, the total number of data bytes that can be transferred are not limited.

##### (3) The byte format of data transmission (The sequence of data transmission)

###### a. The byte format during data setting to M65669FP are shown as follows.

In right after the forming of serial data transmitting state, the slave address 24h (00100100b) is transferred. Afterwards, the internal register address (1 byte) and setting data (by 1 byte unit) are transferred successively. Several bytes of setting data can be handled in the one transmission. In this operation, the setting data are written into the address register whose address is increased one in initially transferred internal register address.

###### b. The byte format during data reading from M65669FP are shown as follows.

Before data reading from M65669FP, whose internal address need to be set by the data reading/transmitting. After the data reading/transmitting, the operation of "serial data transmission completion and start" (described in (1)) is necessary. Continuously, the slave address 25h (00100101b) is sent, and then the inverted read out data are available on ACK. Several bytes of writing data can be handled in the one transmission, too. In this operation, the setting data also are written into the address register whose address is increased one in initially transferred internal register address.

---

Notice ; This is not the final specification.  
Some of information in this document are  
subject to changes.

<The examples of serial byte transmission format>

(1) The writing operation of the setting data (AAh) into M65669FP internal address of 00h

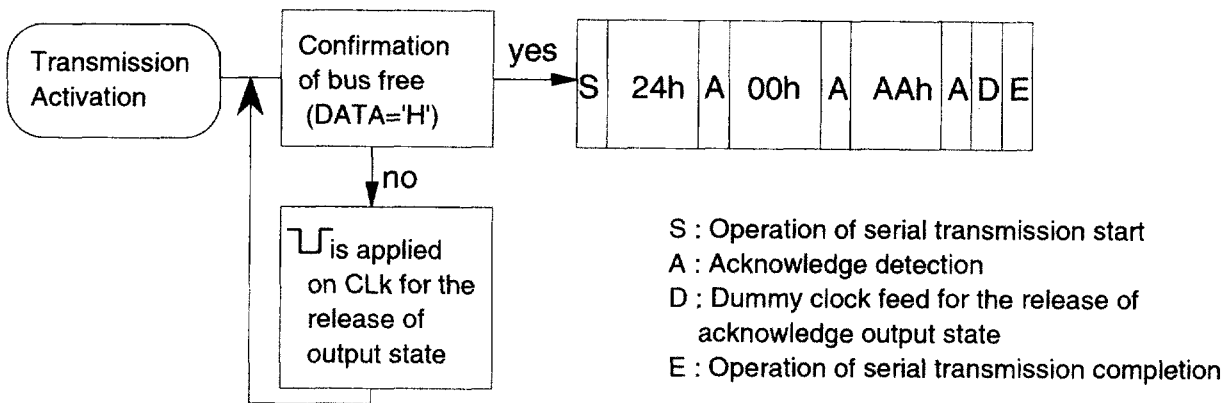

(2) The writing operation of the setting data (FFh, 80h, EEh) into M65669FP internal address of 04h ~ 06h

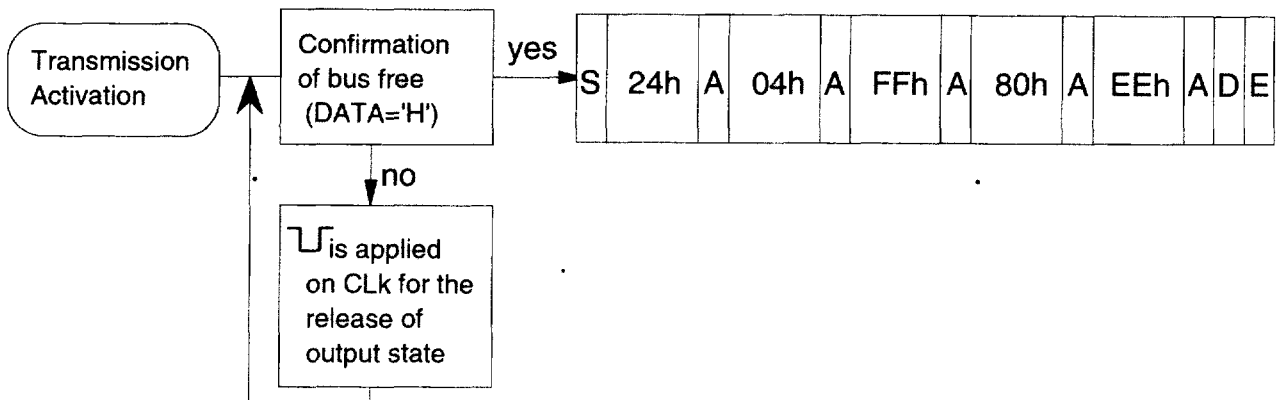

(3) The reading operation of the setting data from M65669FP internal address of 00h

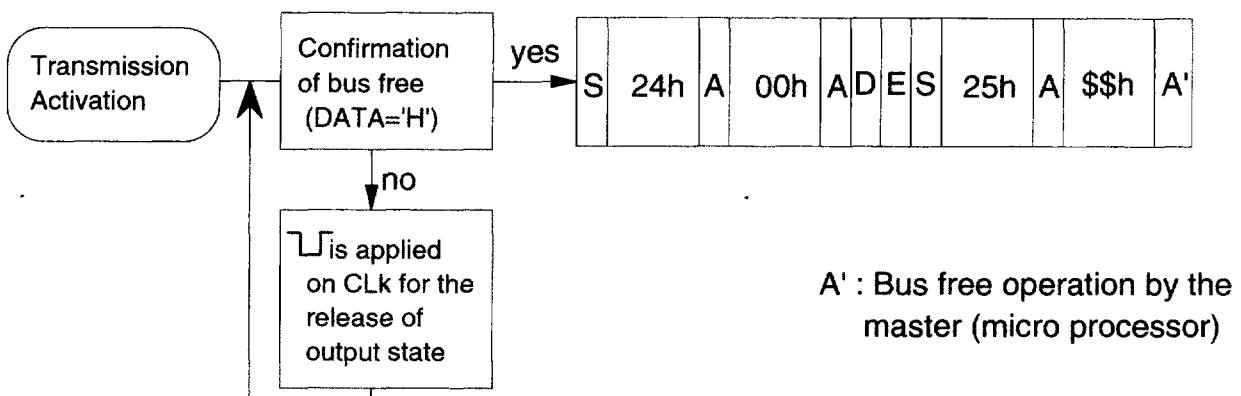

Notice ; This is not the final specification.  
 Some of information in this document are  
 subject to changes.

**V3.1**

PICTURE-IN-PICTURE  
 SIGNAL PROCESSING

(4) The reading operation of the setting data from M65669FP internal address of  
 04h ~ 06h

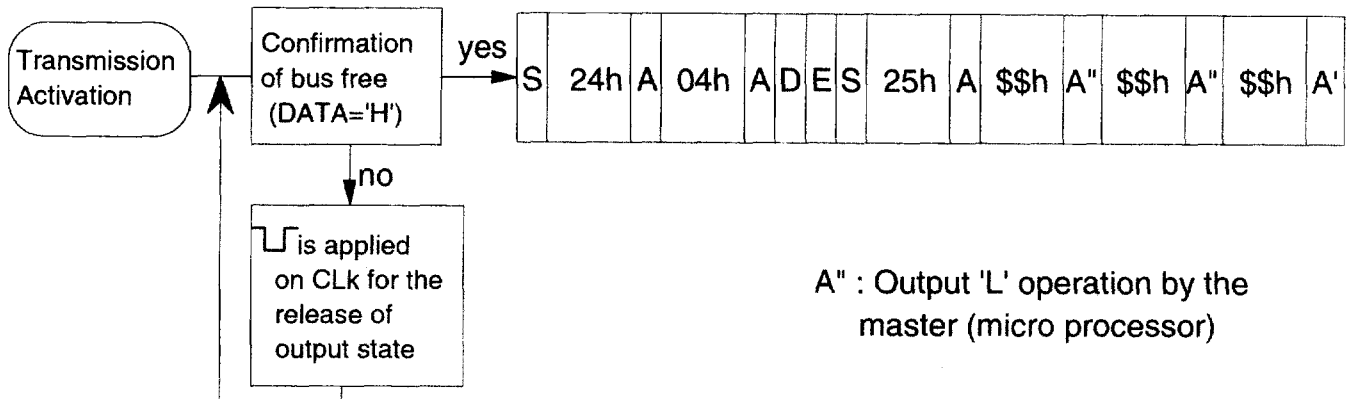

**<Timing Diagram>**

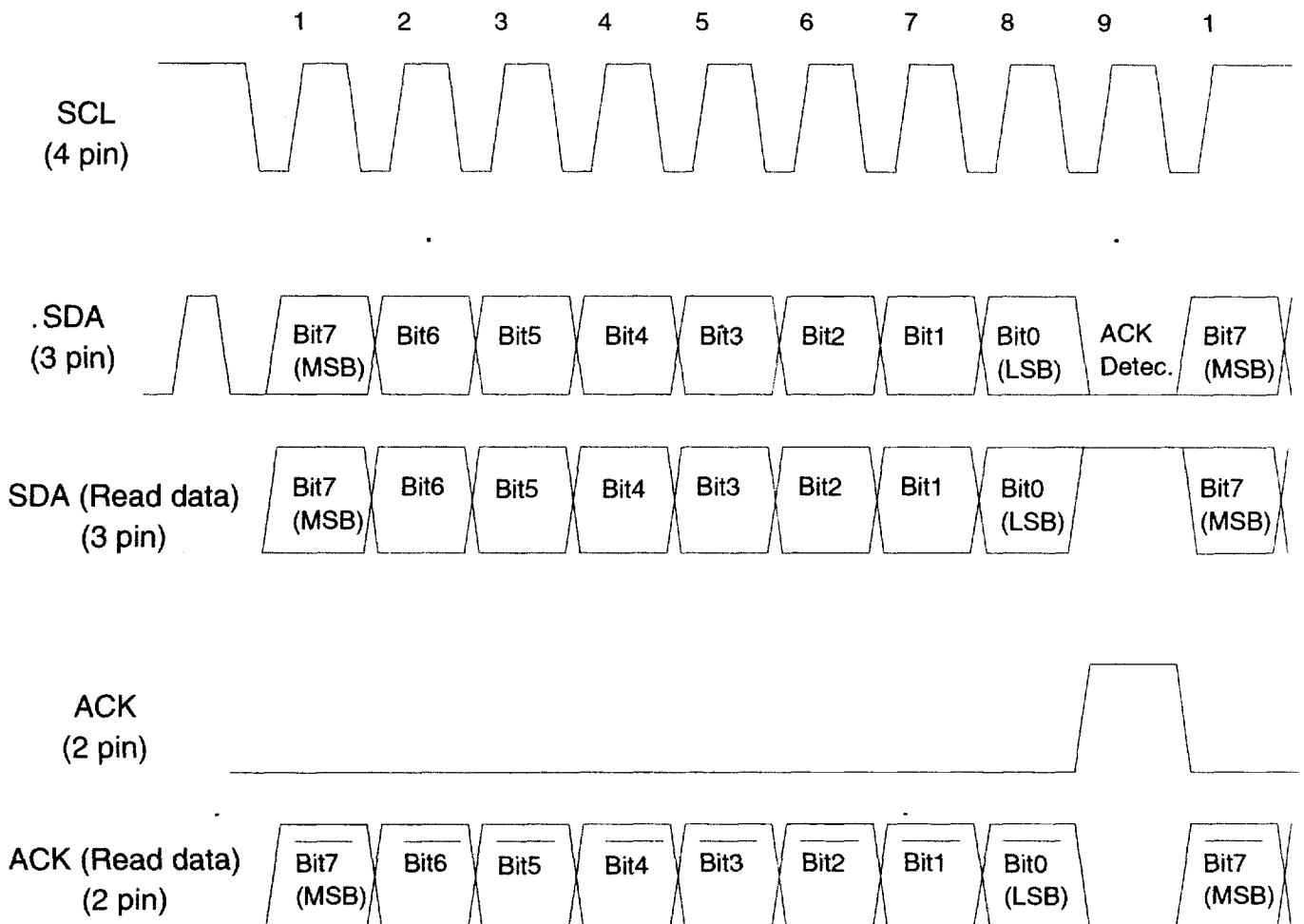

PRELIMINARY

MITSUBISHI DIGITAL TV ICs  
M65669SP/FP

Notice ; This is not the final specification.  
Some of information in this document are  
subject to changes.

V3.1

PICTURE-IN-PICTURE  
SIGNAL PROCESSING

Internal register information (preliminary : *functional reference only, address and bit definition NOT fixed*)

		symbol	remarks
00h	<7>	DISP	Sub picture display : [0] off , [1] on
	<6>	SIZE_V	Sub picture vertical size : [0] 1/9, [1] 1/16
	<5>	SIZE_H	Sub picture horizontal size : [0] 1/9, [1] 1/16
	<4>	WEN	Sub picture : [0] Still, [1] Moving
	<3>	BGC	Back ground display : [0] off, [1] on
	<2>	BGCS	Sub picture mute : [0] off, [1] on
	<1>	FREE_RUN	VCXO oscillation : [0] Lock, [1] Free run
	<0>	RVS	HD / VD input synchronous mode selection : [0] sync., [1] async.
01h	<7:0>	VXA<7:0>	Sub picture vertical position
02h	<7:0>	HXA<7:0>	Sub picture horizontal position
03h	<7>	DECODE	Sub picture color decoder reset : [1] reset
	<6:0>	CONTRAST<6:0>	Sub picture Y DAC output amplitude control
04h	<7>	KILLER	Sub picture color killer : [0] enable, [1] disable
	<6:0>	COLOR_SAT<6:0>	Sub picture U and V DAC output amplitude control
05h	<7>	GRC	Frame display : [0] off , [1] on
	<6>	YUVN_RGB_SEL	PIP output mode selection : [0] YUV , [1] RGB
	<5:0>	TINT<5:0>	Sub picture tint control
06h	<7:6>	EXT_SC_SEL<1:0>	Sub picture C-Sync sep. input selection : [0] Digital, [1] 23 pin input, [2] external, [3] Int. analog
	<5:4>	DCONT<1:0>	Sub picture digital sync sep.threshold setting
	<3:0>	HT<3:0>	Sub picture display timing adjust
07h	<7:6>	EXPORT<1:0>	Ext. port setting (7 pin) : [0or1]—, [2]"0" output, [3]"1" output
	<5:0>	BG_START<5:0>	Sub picture BGP position setting
08h	<7:4>	ADJ<3:0>	Main/Sub switch delay control
	<3:0>	YDL<3:0>	Sub picture Y/C delay adjust
09h	<7:5>	BGBY<2:0>	Back ground U level setting
	<4:0>	Y_OFFSET<4:0>	Sub picture Y bright control
0Ah	<7>	VCHIP_ONLY	V-chip decode mode : [0] on , [1] off
	<6:4>	BGRY<2:0>	Back ground V level setting
	<3:0>	BGY<3:0>	Back ground Y level setting
0Bh	<7:4>	pedestu<3:0>	Sub picture U pedestal level
	<3:0>	pedestv<3:0>	Sub picture V pedestal level
0Ch	<7>	SIZE_Q	Sub picture vertical size : [0] 1/9 or 1/16, [1] 1/4
	<6>	SET_ACC	Address 0Dh, 0Ch setting mode : [0]default , [1] enable set
	<5:4>	SYSTEM_MODE<1:0>	System : [0]NTSC, [1]NTSC/PAL-M, [2]NTSC/PAL-N, [3]All
	<3>	SET_SIZE	Address 11h, 12h, 13h setting mode : [0]default , [1] enable set
	<2>	SET_VCHIP	Address 15h, 16h, 17h setting mode : [0]default , [1] enable set
	<1>	INV_UV	Invert U, V output value : [0] off, [1] on
	<0>	CROSS_SEL	Sub picture read mode : [0] pixel based, [1] H based
0Dh	<7:6>	SYNC_DELAY<1:0>	Sub picture sync.delay control
	<5:4>	MVP_SEL<1:0>	Sub picture decoder macro vision mode selection
	<3>	C_GAIN_SEL	Sub picture chroma : [0] x1, [1] x2
	<2:0>	INVLEVEL<2:0>	Sub picture decoder macro vision mode threshold
0Eh	<7>	BITSEL	Sub picture Y clamp time constant : [0] x2, [1] x1
	<6>	AFCBITSEL	Sub picture AFC time constant : [0] x2, [1] x1
	<5:0>	ACC_LEVEL<5:0>	Sub picture color decoder amplitude
0Fh	<7>	AUTO_ENABLE	System automatic judgement : [0] off , [1] on
	<6>	BURST_CLOCK_MODE	VCXO mode selection : [0] 1H based, [1] 2H based
	<5>	EVENUPRA	Invert sub picture display beginnig line field : [0] normal, [1] invert
	<4>	INV_WFF	Invert sub picture field definition : [0] normal, [1] invert
	<3>	INV_RFF	Invert main picture field definition : [0] normal, [1] invert
	<2>	RVHS	for test : [0] off, [1] on
	<1:0>	-	No assignment

PRELIMINARY

MITSUBISHI DIGITAL TV ICs  
M65669SP/FP

Notice ; This is not the final specification.  
Some of information in this document are  
subject to changes.

V3.1

PICTURE-IN-PICTURE  
SIGNAL PROCESSING

Internal register information (preliminary : *functional reference only, address and bit definition NOT fixed*)

10h	<7>	INVDECODE		Sub picture decoder mode : [0] NTSC, [1] PAL
	<6>	AVERAGE		Sub picture decoder mode : [0] 1H based, [1] 2H based
	<5:0>	PALHY<5:0>		Threshold control of ident judgement of sub picture decoder
11h	<7>	WDOF_KILLER_ON		Sub picture killer on when its vert. sync lost : [0] on, [1] off
	<6:0>	HYA<6:0>	38h/29h	Sub picture horizontal display pixel
12h	<7:0>	VYA<7:0>	44h/33h	Sub picture vertical display line number
13h	<7:2>	HX<5:0>		Sub picture horizontal capture position
	<1:0>	HP<1:0>		Sub picture horizontal capture position
14h	<7:6>	MVC<1:0>		Sub picture C-sync input mask period : [0] 48us, [1] 44us, [2] 53us, [3] off
	<5:0>	VXS<5:0>		Sub picture sample start line
15h	<7>	-	0	Test use
	<6>	PLUS	0	Test use
	<5>	SW_TESTEN	0	Test use
	<4:0>	LINE_NUM<4:0>	11h	Data slicer line selection
16h	<7:0>	STB_DLY<7:0>	40h	Data slicer start bit detection parameter
17h	<7:0>	L_LEVEL<7:0>	82h	Data slicer data slice parameter
18h	<7>	EDGE_ON		Frame data independent control : [0] disable, [1] enable
	<6:4>	BGBY_EDGE<2:0>		Frame data independent B-Y data setting
	<3:0>	BGY_EDGE<3:0>		Frame data independent Y data setting
19h	<7:5>	BGRY_EDGE<2:0>		Frame data independent R-Y data setting
	<4>	HPFOFF		Sub picture Y output HPF : [0]on, [1]off
	<3:0>	FREE_RUN_ADJ<3:0>		Frequency adjustment control when free run mode
1Ah	<7:0>	SUB_PALM_JUDGE<7:0>		Parameter setting for PAL-M judgement
1Bh	<7:6>	NO_BST_LEVEL		for test
	<5:4>	BW_DET_LEVEL		for test
	<3:0>	HADJ<3:0>		for test
1Ch	<7>	PINOE		for test
	<6>	BGP_M_SEL		for test
	<5:0>	BST_BY<3:0>		for test
1Dh	<7:0>	PINOE<7:0>		for test
1Eh	<7:0>	-		No assignment
1Fh	<7:6>	SYSTEM_STATE<1:0>		System state : [0] NTSC, [1] NTSC, [2] PAL-N, [3]N.A. (Read only)
	<5>	MAIN_PALN		Main is : [0] not PAL-N, [1] PAL-N(Read only)
	<4>	SUB_UNLOCK		VCXO is : [0] Lock, [1] un-Lock(Read only)
	<3>	SUB_PALN		Sub is : [0] not PAL-N, [1] PAL-N(Read only)
	<2>	RDOF		Main picture vertical sync is : [0] not present, [1] present(Read only)
	<1>	MAIN_BW		Test use (Read only)
	<0>	WDOF		Sub picture vertical sync is : [0] not present, [1] present (Read only)
20h	<7:6>	NOISE<1:0>		Test use (Read only)
	<5>	WDOF		Sub picture vertical sync detection (Read only)
	<4>	EDS_ACK2		EDS data flag of even field (Read only) : [0] no EDS, [1] EDS
	<3>	EDS_ACK1		EDS data flag of odd field (Read only) : [0] no EDS, [1] EDS
	<2>	SIGNAL_OK		Test use (Read only)
	<1>	READ_REQB		Read request of even field (Read only) : [0] no, [1] request
	<0>	READ_REQA		Read request of odd field (Read only) : [0] no, [1] request
21h	<7:0>	PDB<15:8>		Even field Sliced data upper 8 bit (Read only)
22h	<7:0>	PDB<7:0>		Even field Sliced data lower 8 bit (Read only)
23h	<7:0>	PDA<15:8>		Odd field Sliced data upper 8 bit (Read only)
24h	<7:0>	PDA<7:0>		Odd field Sliced data lower 8 bit (Read only)

PRELIMINARY

MITSUBISHI DIGITAL TV ICs  
**M65669SP/FP**

Notice ; This is not the final specification.  
 Some of information in this document are  
 subject to changes.

**V3.1**

PICTURE-IN-PICTURE  
 SIGNAL PROCESSING

Internal register information (preliminary : *functional reference only, address and bit definition NOT fixed*)

		symbol	remarks
25h	<7:0>	FREQ_DIFF_TERM<7:0>	
30h	<7:6>	WPROC<2:1>	
	<5>	TEST_WHV	
	<4>	TI_DELAY90	
	<3>	TI_VFSC	
	<2>	TI_KVFLT	
	<1>	TI_YPROC	
	<0>	SWAP	
	31h	<7>	ACK_OUT_SEL
<6>		SEL_PD_OUT	
<5>		DOFC	
<4>		TI_ZEC	
<3>		TI_SPRF	
<2>		TEST_YT	
<1>		TI_CPROCS	
<0>		TI_MCSEQ	
32h	<7>	TEST_SPRF96K	
	<6>	C_DAC_CTRL	
	<5>	YDAOUTSEL	
	<4>	DISADCLK	
	<3>	INV_PROBE_MSB	
	<2>	DISLOGICCLK	
	<1>	CDAOUTSEL	
	<0>	TEST_RH	
33h	<7:0>	MAN_SEL<7:0>	
34h	<7:6>	ADCCLKSEL<1:0>	
	<5>	RHMS	
	<4>	OUT_SEL	
	<3>	TEST_C27	
	<2>	TEST_DGATE	
	<1>	TEST_MSL	
	<0>	TEST_SGATE	
	35h	<7:6>	DOUT_SEL<1:0>
<5>		PROBESEL	
<4:0>		TMON<4:0>	
36h	<7>	VCXO_TEST<7>	MCK Comp Filter
	<6>	VCXO_TEST<6>	X'tal fCNT2
	<5>	VCXO_TEST<5>	X'tal fCNT1
	<4>	VCXO_TEST<4>	· CNT4
	<3>	VCXO_TEST<3>	· CNT3
	<2>	VCXO_TEST<2>	· CNT2
	<1>	VCXO_TEST<1>	· CNT1
	<0>	VCXO_TEST<0>	o b N A b v æ H f