

Bluetooth Module Data Sheet

Product Description : BlueModule™

Sample Part Number : LBMA465HG1-TEMP
LBMA465HG2-TEMP
LBMA465HG3-TEMP

Product Engineering Section
Bluetooth Modules Department
Component Division III
Murata Manufacturing Co., Ltd.

1. Scope

This specification is applied to the Bluetooth HCI module (BlueModule™).

2. Part Number

New Sample Part Number	LBMA465HG1-TEMP	LBMA465HG2-TEMP	LBMA465HG3-TEMP
HCI Interface	USB	UART (H4)	BCSP *

* BCSP (Blue Core Serial Protocol) is a proprietary of CSR's serial protocol.

3. Rating

	min.	max.	unit
Storage Temperature	-40	+85	deg.C
Supply Voltage :			
VDD_1.8V	-0.4	+2.2	V
VDD_IO	-0.4	+3.7	V
VREG_IN	-0.4	+5.6	V
Other terminal	Vss-0.4	VDD+0.4	V

4. Weight (nominal)

TBD

5. Power Supply Diagram

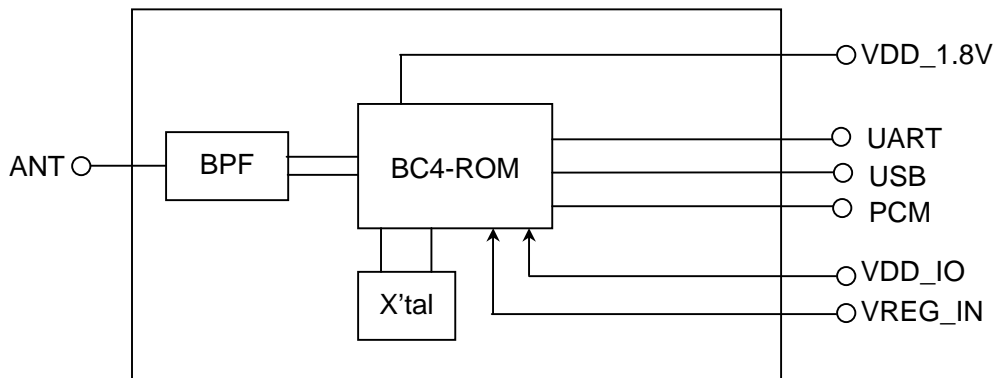

Terminal	3.0 Power Supply	1.8V Power Supply
VDD_1.8V	Bypass capacitor	1.7 to 1.9V
VDD_IO	1.7 to 3.6V	1.7 to 1.9V
VREG_IN	2.6 to 4.2V	NC

6. Dimensions, Marking and Terminal Configurations

<Top View>

<Side View>

<Bottom View>

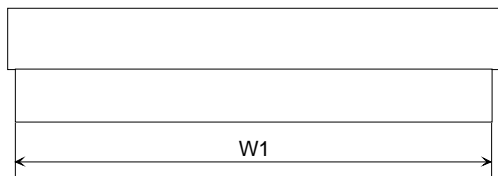
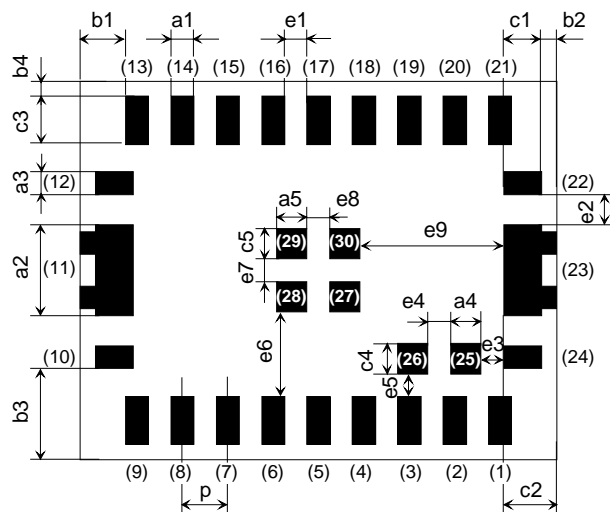
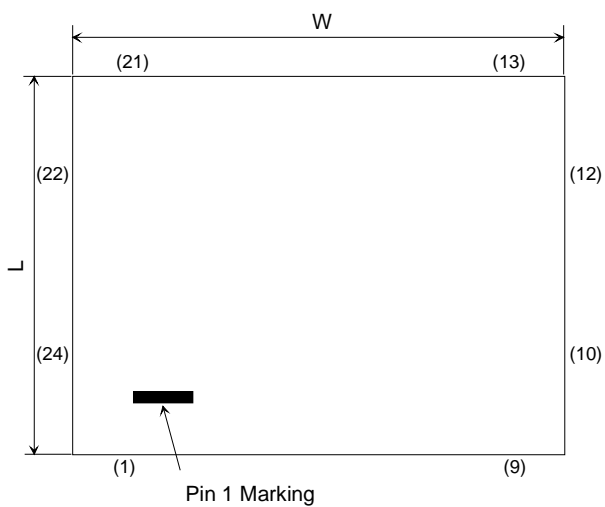

Dimensions

(Unit : mm)

Mark	Dimension	Mark	Dimension	Mark	Dimension
L	5.0 +/- 0.3	W	6.4 +/- 0.3	W1	6.3 +/- 0.3
T	1.5 max.	a1	0.3 +/- 0.1	a2	1.2 +/- 0.1
a3	0.3 +/- 0.1	a4	0.4 +/- 0.1	a5	0.4 +/- 0.1
b1	0.6 +/- 0.2	b2	0.2 +/- 0.2	b3	1.2 +/- 0.2
b4	0.2 +/- 0.2	c1	0.5 +/- 0.1	c2	0.7 +/- 0.1
c3	0.625 +/- 0.1	c4	0.4 +/- 0.1	c5	0.4 +/- 0.1
e1	0.3 +/- 0.1	e2	0.4 +/- 0.1	e3	0.3 +/- 0.1
e4	0.3 +/- 0.1	e5	0.3 +/- 0.1	e6	1.125 +/- 0.100
e7	0.3 +/- 0.1	e8	0.3 +/- 0.1	e9	1.9 +/- 0.1
p	0.6 +/- 0.1	-	-	-	-

Terminal Configurations

Terminal No.	Terminal Name	Pad Type	Description
(1)	PIO_3	Bi-directional with programmable strength internal pull-up/down	Programmable input/output line
(2)	RESETB	CMOS input with weak internal pull-up	Reset if low. Input dedounced so must be low for >5ms to cause a reset
(3)	PCM_OUT	CMOS output, tri-state with weak internal pull-down	Synchronous data output
(4)	PCM_SYNC	Bi-directional with weak internal pull-down	Synchronous data sync
(5)	PCM_IN	CMOS input, with weak internal pull-down	Synchronous data input
(6)	PCM_CLK	Bi-directional with weak internal pull-down	Synchronous data clock
(7)	UART_RTS	CMOS output, tri-state with weak internal pull-up	UART request to send active low
(8)	UART_RX	CMOS input, with weak internal pull-down	UART data input active high
(9)	UART_TX	CMOS output, tri-state with weak internal pull-up	UART data output active high
(10)	UART_CTS	CMOS input, with weak internal pull-down	UART clear to send active low
(11)	GND		
(12)	ANT		
(13)	GND		
(14)	PIO_0	Bi-directional with programmable strength internal pull-up/down	Programmable input/output line
(15)	PIO_1	Bi-directional with programmable strength internal pull-up/down	Programmable input/output line
(16)	VREG_IN	Regulator input (VDD_REG)	Regulator input
(17)	VDD_IO	VDD	Positive supply for UART, USB, AIO, PIO, other digital input/output port.
(18)	VDD_1.8V	VDD	Positive supply for internal digital circuitry, RF, VCO, synthesizer, analogue circuitry.
(19)	PIO_4	Bi-directional with programmable strength internal pull-up/down	Programmable input/output line
(20)	PIO_5	Bi-directional with programmable strength internal pull-up/down	Programmable input/output line
(21)	PIO_6	Bi-directional with programmable strength internal pull-up/down	Programmable input/output line
(22)	PIO_7	Bi-directional with programmable strength internal pull-up/down	Programmable input/output line
(23)	GND		
(24)	PIO_2	Bi-directional with programmable strength internal pull-up/down	Programmable input/output line
(25)	USB_D-	Bi-directional	USB data minus
(26)	USB_D+	Bi-directional	USB data plus
(27)	PIO_10	Bi-directional with programmable strength internal pull-up/down	Programmable input/output line
(28)	PIO_8	Bi-directional with programmable strength internal pull-up/down	Programmable input/output line
(29)	GND		
(30)	PIO_9	Bi-directional with programmable strength internal pull-up/down	Programmable input/output line

Preliminary & Confidential

< Specification may be changed by Murata without notice >

Murata Manufacturing Co., Ltd.

7. Electrical Characteristics

7-1. Operating Condition

7-1-1. UART operation

	min.	typ.	max.	unit
Operating Temperature	-20	+25	+75	deg.C
Supply Voltage : VDD_1.8V	1.7	1.8	1.9	V
VDD_IO	1.7	3.0	3.6	V
VREG_IN	2.6	3.0	4.2	V

7-1-2. USB operation

	min.	typ.	max.	unit
Operating Temperature	-20	+25	+75	deg.C
Supply Voltage : VDD_1.8V	1.7	1.8	1.9	V
VDD_IO	3.1	3.3	3.6	V
VREG_IN	2.6	3.0	4.2	V

7-2. DC/RF Characteristics

7-2-1. Normal Condition : +25deg.C, VDD_IO=VREG_IN=3.0V

Items	Contents			
Bluetooth specification	Ver 2.0 + EDR			
Channel spacing	1MHz			
Number of RF channel	79			
Power class	2			
Operation mode (Rx/Tx)	Time division multiplex either transmit or receive frequency hopping after one Rx/Tx Cycle			
	min.	typ. (nominal)	max.	unit
1.DC Current				
1) DH1 Packet	-	40		mA
2) DH3 Packet	-	43		mA
3) DH5 Packet	-	46		mA

-Tx Characteristics-	min.	typ. (nominal)	max.	unit
2.Frequency Range	2400 to 2483.5			MHz
3.Output Power	-6	1.2	4	dBm
4.-20dB Bandwidth	-	0.8	1	MHz
5.Adjacent Channel Power * ¹				
1) M-N=-2,+2	-		-20	dBm
2) M-N=-3,-4,-5	-		-40	dBm
3) M-N=+3,+4,+5	-		-40	dBm
6.Modulation Characteristics				
1) Modulation f _{1avg}	140	155	175	kHz
2) Modulation f _{2max}	115	145	-	kHz
3) f _{2avg} / f _{1avg}	0.8	1.0	-	
7.Initial Carrier Frequency Tolerance	-75	10	75	kHz
8.Carrier Frequency Drift				
1) 1slot	-25	+/-10	25	kHz
2) 3slot	40	-	40	kHz
3) 5slot	40	-	40	kHz
4) Maximum drift rate	-20	+/-7	20	kHz/50us
9.Out of Band Spurious Emissions				
1) 30MHz - 1000MHz (Operation mode)	-	-	-36	dBm
2) 1GHz – 12.75GHz (Operation mode)	-	-	-30	dBm
3) 1.8GHz – 1.9GHz (Operation mode)	-	-	-47	dBm
4) 5.15GHz – 5.3GHz (Operation mode)	-	-	-47	dBm
-Rx Characteristics-	min.	typ. (nominal)	max.	unit
11.Sensitivity (BER ≤ 0.1%)				
1) 2402MHz	-	-84	-70	dBm
2) 2441MHz	-	-84	-70	dBm
3) 2480MHz	-	-83.5	-70	dBm
12.C/I Performance (BER ≤ 0.1%) * ²				
1) co-channel Ratio (-60dBm input)	-	-	11	dB
2) 1MHz Ratio (-60dBm input)	-	-	0	dB
3) 2MHz Ratio (-60dBm input)	-	-	-30	dB
4) 3MHz Ratio (-67dBm input)	-	-	-40	dB
5) Image Ratio (-67dBm input)	-	-	-9	dB
6) Image +/-1MHz Ratio (-67dBm input)	-	-	-20	dB
13.Blocking Performance (BER ≤ 0.1%) * ³				
1) 30MHz to 2000MHz	-10	-	-	dBm
2) 2000MHz to 2400MHz	-27	-	-	dBm
3) 2500MHz to 3000MHz	-27	-	-	dBm
4) 3000MHz to 12.75GHz	-20	-	-	dBm
14.Intermodulation Performance (BER ≤ 0.1% , -64dBm input)	-39		-	dBm
15. Maximum Input Level (BER ≤ 0.1%)	-20		-	dBm

*1 Up to three spurious responses within Bluetooth limits are allowed.

*2 Up to five spurious responses within Bluetooth limits are allowed.

*3 Up to twenty-four spurious responses within Bluetooth limits are allowed.

Note:

The above-mentioned values have been obtained according to our own measuring methods (testing jig : Fig.1) and may vary depending on the circuit, in which this component is actually incorporated.

Therefore, you are kindly requested to test the performance of this component incorporating in your set.

8. Other Specification and Methods

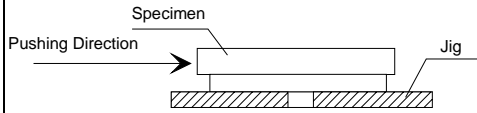
No.	Items		Specifications	Test Methods
1	Vibration Resistance	Appearance	No severe damages	Solder specimens on the testing jig shown in appended Fig.1 by an solder. The soldering shall be done either by iron or reflow and be conducted with care so that the soldering is uniform and free of defect such as by heat shock. Frequency : 10 to 2000 to 10 Hz Acceleration : 196 m/s ² Direction : X,Y,Z 3axes Period : 2 h on each direction (Total 6 h)
		Electrical Specifications	Satisfy specifications listed in paragraph 7-2-2.	
2	Shock	Appearance	No severe damages	Solder specimens on the testing jig shown in appended Fig.1 by an solder. The soldering shall be done either by iron or reflow and be conducted with care so that the soldering is uniform and free of defect such as by heat shock. Pulse Wave : Sine Half Wave Acceleration : 980 m/s ² (Peak) Period : 6 ms. Cycle : 10 times
		Electrical Specifications	Satisfy specifications listed in paragraph 7-2-2.	
3	Deflection		No damage with 1mm deflection	Solder specimens on the testing jig shown in appended Fig.3 by an solder. The soldering shall be done either by iron or reflow and be conducted with care so that the soldering is uniform and free of defect such as by heat shock.
4	Soldering strength (Push Strength)		9.8 N min.	Solder specimens on the testing jig shown in appended Fig.3 by an solder. As shown below, apply pushing force at 0.5 mm/s until electrode pads are pealed off or ceramics are broken. Pushing force is applied as show below. 
5	Solderability of Termination		75% of the terminations is to be soldered evenly and continuously.	Immerse specimens first a ethanol solution of rosin (25% rosin in weight proportion), then in an solder solution for 2+/-0.5 s at 230+/-5 deg.C. Preheat : 100 to 120 deg.C, 60 s Solder Paste : Eutectic Solder Flux : Solution of ethanol and rosin (25% rosin in weight proportion)
6	Resistance to Soldering Heat (Dipping)	Appearance	No severe damages	Immerse the chip in an solder solution of 260+/-5 deg.C for 20+/-0.5 s (flow soldering bath) after preheating for 1 min at 120 to 150 deg.C. Then set it for 2 to 24 h at room temperature and measure.
7	Resistance to Soldering Heat (Reflow)	Appearance	No severe damages	Preheat Temperature : 150+/-10 deg.C Preheat Period : 60 s Peak Temperature : 230+/-5 deg.C Peak Temp. Period : 10 s Specimens are soldered twice with the above condition, then kept in room condition for 24 h before measurements.
		Electrical Specifications	Satisfy specifications listed in paragraph 7-2-2.	

No.	Items		Specifications	Test Methods		
8	Temperature Cycle	Appearance	No severe damages	Set the specimens to the supporting jig in the same manner and under the same condition as Fig.1 and conduct the 100 cycles according to the temperatures and time shown in the following table.		
		Electrical Specifications	Satisfy specifications listed in paragraph 7-2-2.			
				Step	1	2
				Temp. (deg.C)	Min Strage Temp. +0/-3	Max Strage Temp. +3/-0
				Time (min)	30+/-3	30+/-3
9	Humidity Load Life	Appearance	No severe damages	Temperature : 85 +/-2 deg.C Humidity : 80 to 85 %RH Period : 500 +48/-0 h Room Condition : 2 to 24 h Supply Voltage : 3.6V D.C.		
		Electrical Specifications	Satisfy specifications listed in paragraph 7-2-2.			
10	High Temp. Load Life	Appearance	No severe damages	Temperature : 85 +/-2 deg.C Period : 500 +48/-0 h Room Condition : 2 to 24 h Supply Voltage : 3.6V D.C.		
		Electrical Specifications	Satisfy specifications listed in paragraph 7-2-2.			

Excessive mechanical force or thermal stress may damage the products. Appropriate handling is required.

9. Production Site

Fukui Murata Manufacturing Co., Ltd.

10. Reference Circuit

10-1. UART interface

10-1-1. UART I/F, 3.0V Power Supply

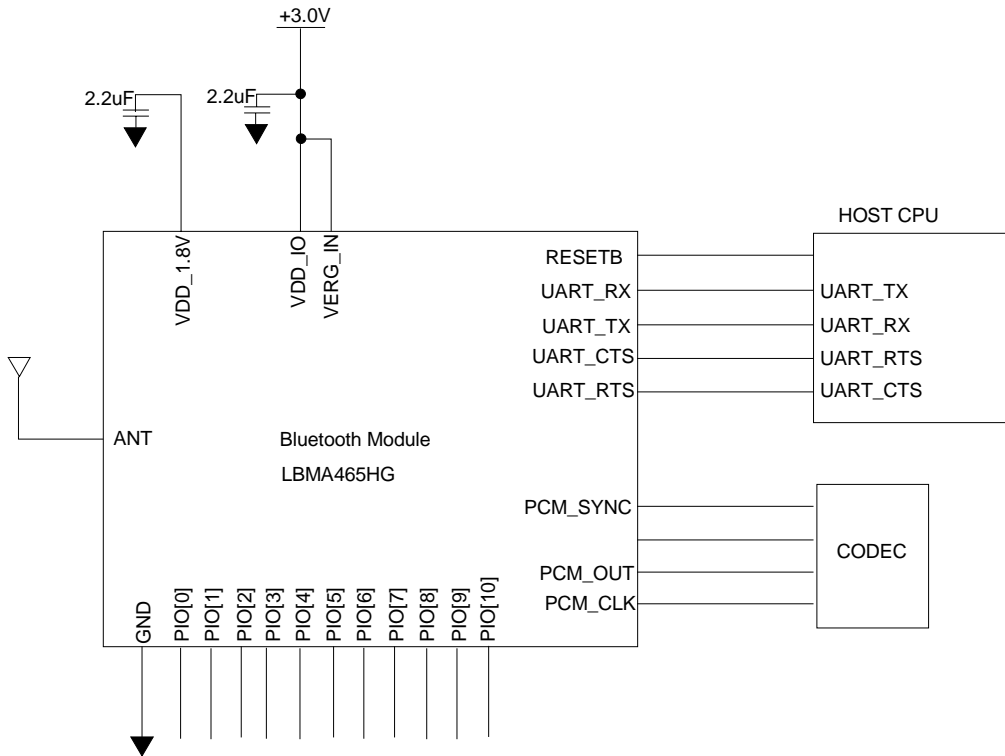

10-1-2. UART I/F, 1.8V Power Supply

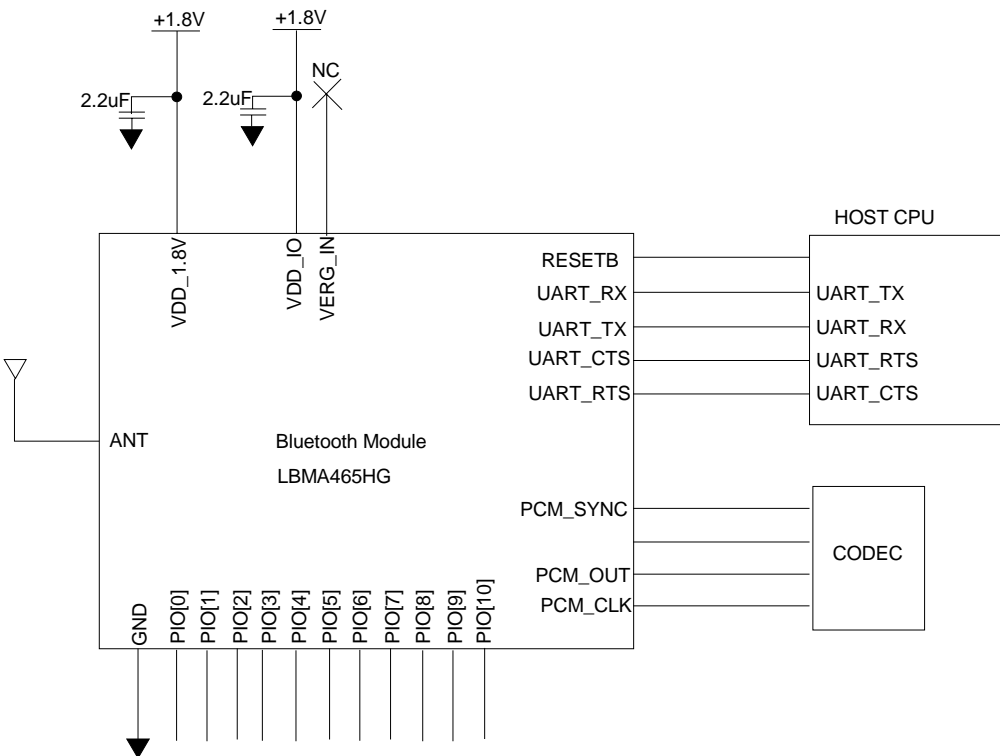

10-2. USB interface

10-2-1. USB I/F, 3.3V Power Supply

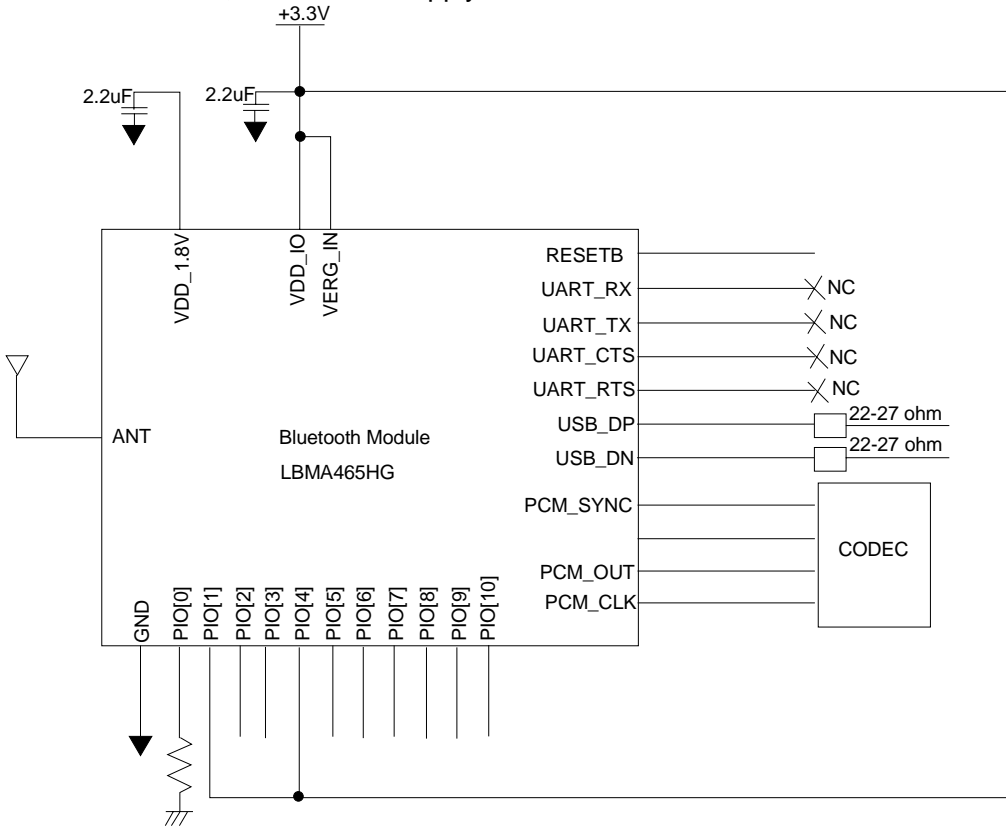

10-2-2. USB I/F, 3.3V / 1.8V Power Supply

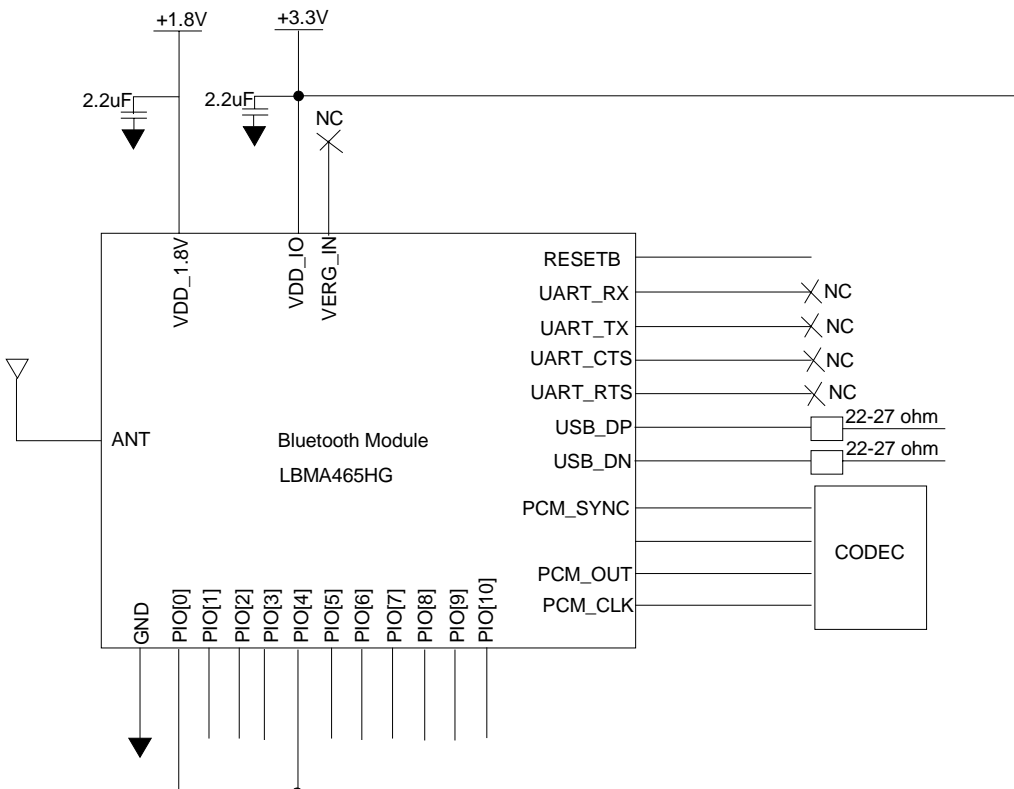

10-2-3. USB Self Powered Mode

In self-powered mode, the circuit is powered from its own power supply and not from the VBUS (5V) line of the USB cable. It draws only a small leakage current (below 0.5mA) from VBUS on the USB cable. This is the easier mode for which to design, as the design is not limited by the power that can be drawn from the USB hub or root port. However, it requires that VBUS be connected to LBMA465HG via a resistor network (Rvb1 and Rvb2), so LBMA465HG can detect when VBUS is powered up. LBMA465HG will not pull USB_DP high when VBUS is off.

Self-powered USB designs (powered from a battery or PSU) must ensure that a PIO line is allocated for USB pull-up purposes. A 1.5K 5% pull-up resistor between USB_DP and the selected PIO line should be fitted to the design.

Failure to fit this resistor may result in the design failing to be USB compliant in self-powered mode. The internal pull-up in BlueCore is only suitable for bus-powered USB devices, e.g., dongles.

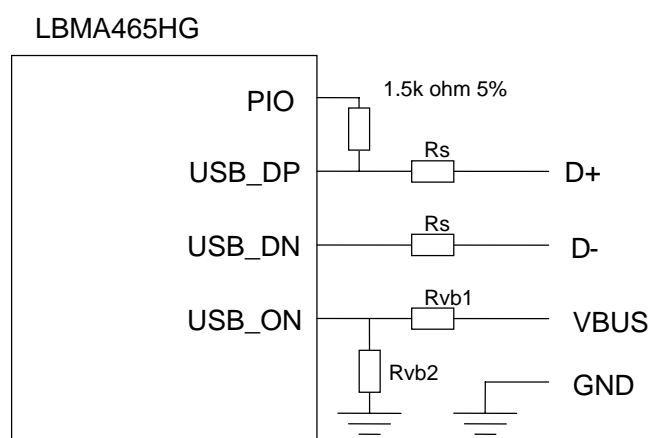

The terminal marked USB_ON can be any free PIO pin. The PIO pin selected must be registered by setting “PSKEY_USB_PIO_VBUS” to the corresponding pin number. And the PIO line used to control the pull-up resistor on the USB D+ line must be registered by setting “PSKEY_USB_PIO_PULLUP”.

“PSKEY_USB_PIO_VBUS(0x02D1)”

The PIO line used for USB VBus detection. This must be one of the 2 available interrupt input pins (4 or 5). The absence of this key indicates that this feature is not in use. This value is only used if the chip is presenting its USB interface. Default setting is no value.

“PSKEY_USB_PIO_PULLUP(0x02D0)”

The PIO line used to control the pull-up resistor on the USB D+ line. The absence of this key in the ps indicates that this feature is not in use.

This value is only used if the chip is presenting its USB interface.

See the description of PSKEY_HOST_INTERFACE.

On BlueCore 2, there are 16 PIO lines, 0 to 15, but 12 to 15 are not available for the USB pullup.

However, an internal pullup can be used by setting this key to 16. Default setting is “16” = internal pull up mode.

Note:

USB_ON is shared with LBMA465HG PIO terminals.

The resistor values are indicated following table.

Identifier	Value	Functions
Rs	22-27 ohm	Impedance matching to USB cable
Rvb1	22k ohm 5%	VBUS ON sense divider
Rvb2	47k ohm 5%	VBUS ON sense divider

10-3. UART Bypass

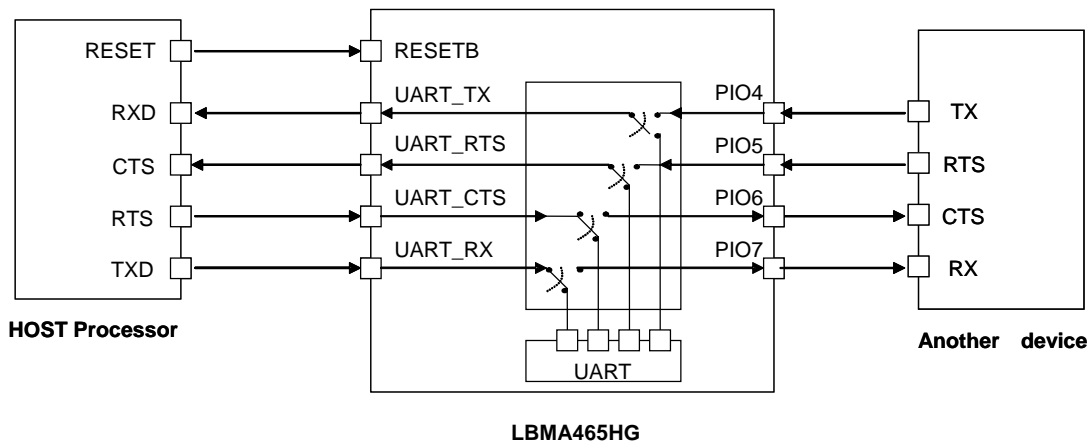

10-3-1. UART Configuration While RESET is Active

The UART interface for LBMA465HG while the chip is being held in reset is tri-state. This will allow the user to daisy chain devices onto the physical UART bus. The constraint on this method is that any devices connected to this bus must tri-state when LBMA465HG reset is de-asserted and the firmware begins to run.

10-3-2. UART Bypass Mode

Alternatively, for devices that do not tri-state the UART bus, the UART bypass mode on LBMA465HG can be used. The default state of LBMA465HG after reset is de-asserted; this is for the host UART bus to be connected to the LBMA465HG UART, thereby allowing communication to LBMA465HG via the UART.

In order to apply the UART bypass mode, a BCCMD command will be issued to LBMA465HG. Upon this issue, it will switch the bypass to PIO[7:4] as above figure indicates. Once the bypass mode has been invoked, LBMA465HG will enter the Deep Sleep state indefinitely.

In order to re-establish communication with LBMA465HG, the chip must be reset so that the default configuration takes effect.

Therefore, it is not possible to have active Bluetooth links while operating the bypass mode.

10-3-3. Current Consumption in UART Bypass Mode

The current consumption for a device in UART bypass mode is equal to the values quoted for a device in standby mode

Fig.1

Measurement Board

TBD

Fig.2

Land Pattern

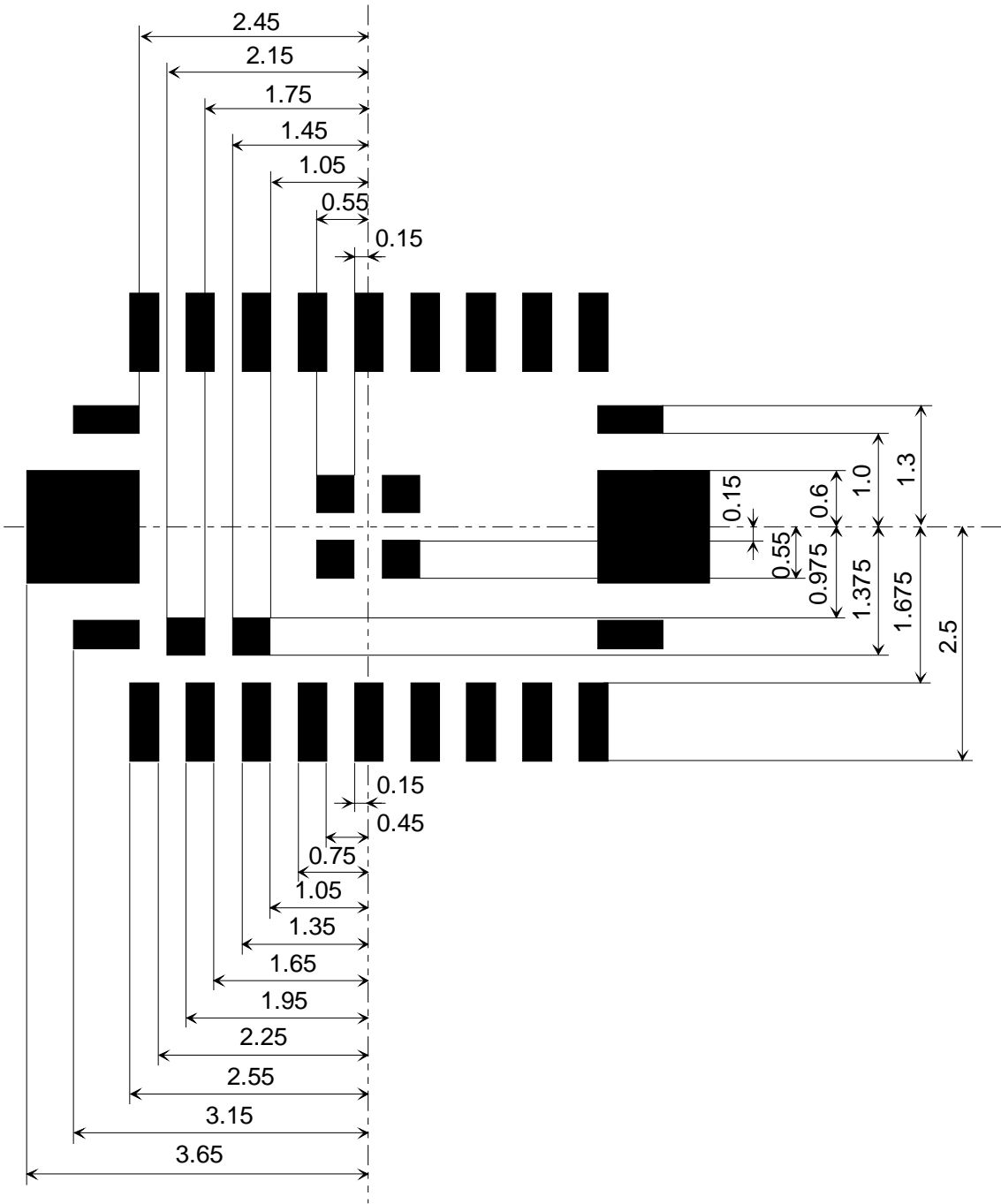

(unit : mm)

Fig.3

Testing Board

TBD

Mounted Situation

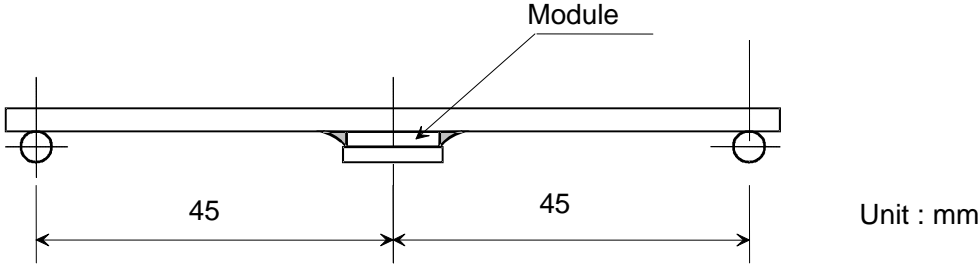

Testing Method

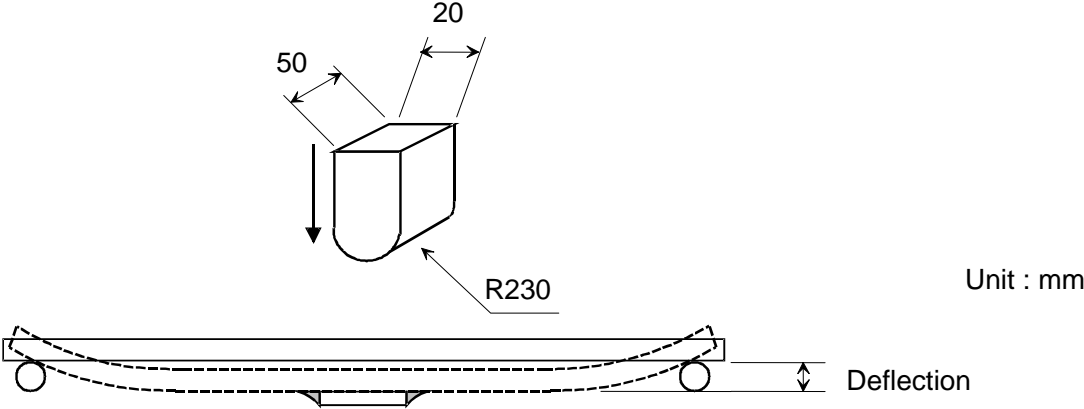

(3) Taping Diagrams

- [1] Feeding Hole : As specified in (1)
- [2] Hole for Chip : As specified in (1)
- [3] Cover Tape : 62um in thickness
- [4] Base Tape : As specified in (1)

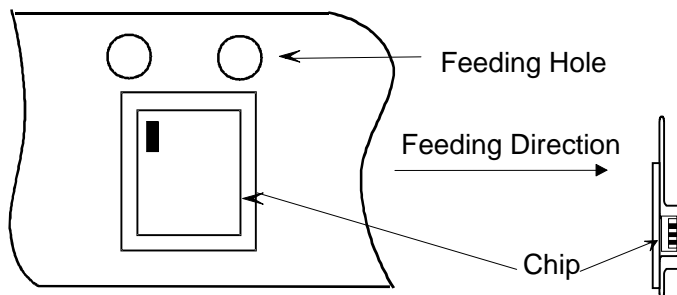
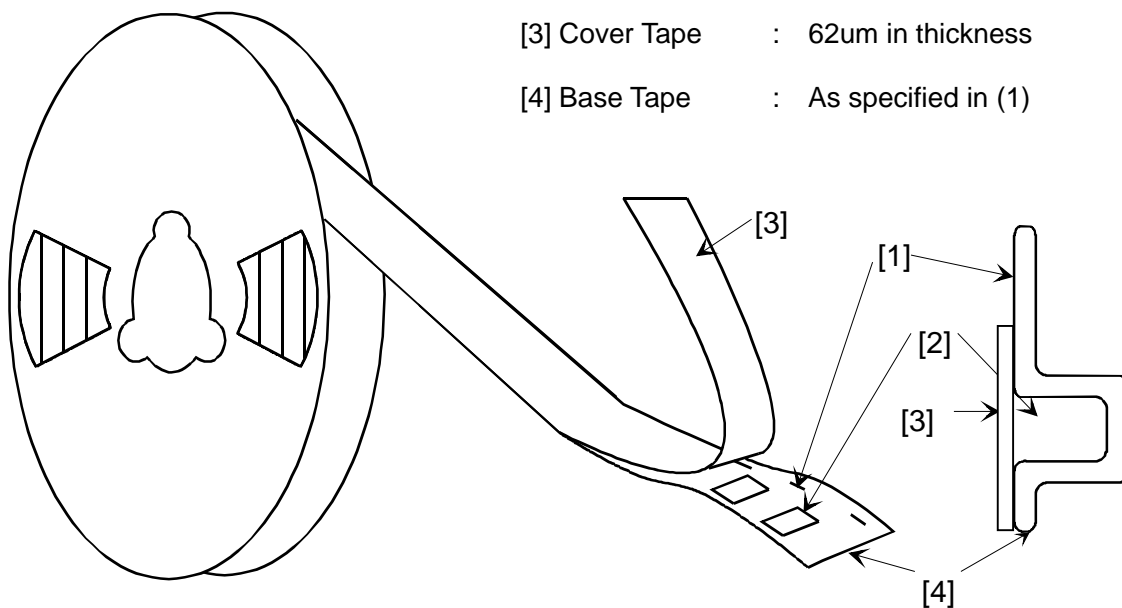

(4) Leader and Tail tape

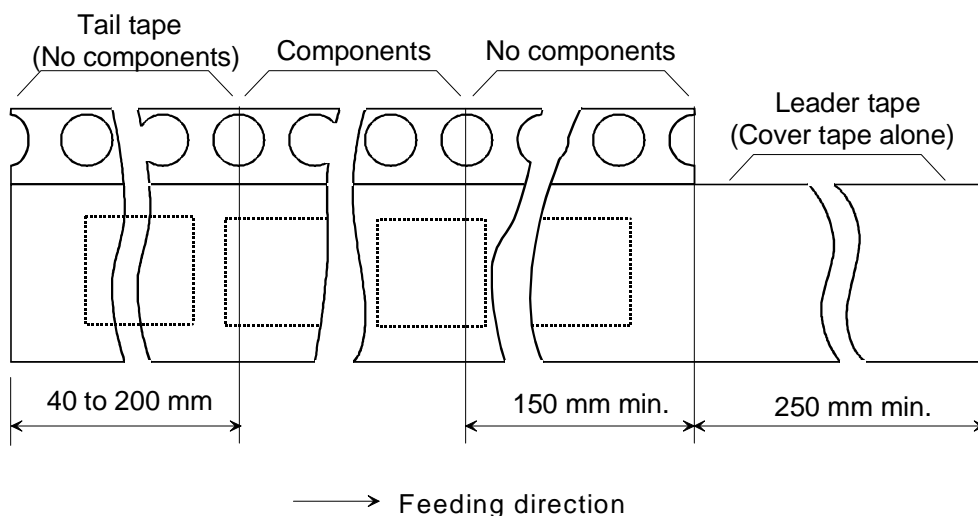

- (5) The tape for chips are wound clockwise, the Feeding Holes to the right side as the tape is pulled toward the user.
- (6) The Cover Tape and Base Tape are not adhered at no components area for 250 mm min.
- (7) Tear off strength against pulling of Cover Tape : 5 N min.
- (8) Packaging unit : 1000 pcs./ Reel
- (9) Material
 - Base Tape : Plastic
 - Reel : PlasticCover Tape , Base Tape and Reel are made the anti-static processing.
- (10) Peeling of force : 0.7 N max. in the direction of peeling as shown below.

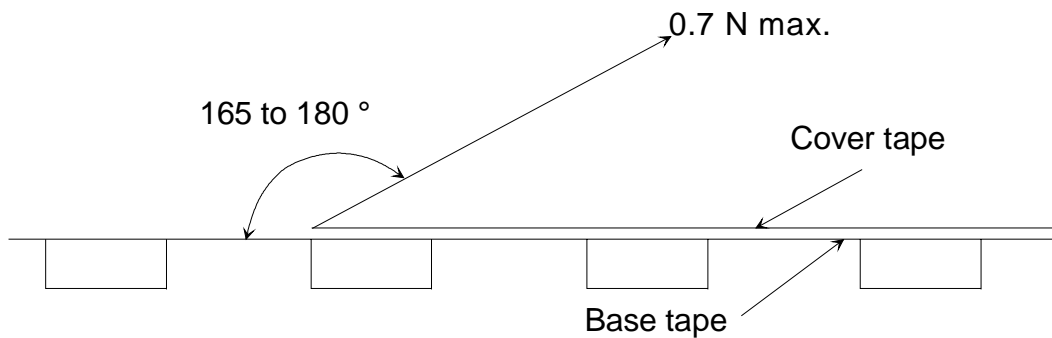

NOTICE

1. Storage Conditions:

The product shall be stored under the following conditions in order not to damage the solderability of the external electrodes.

- The product shall be stored without opening the packing and at the ambient temperature between 5 and 30 deg.C and humidity between 20 and 70 %RH. And the product shall be used within 6 months after reception. (Packing materials, in particular, may be deformed at the temperature over 45 deg.C.)
- After opening the packing, the product shall be stored at 5 to 30 deg.C / \leq 60 %RH and the product shall be used within 48 hours. If the product is not used within 48 hours after opening the packing, the product shall be baked under the following conditions.

Baking condition : 125 +/-5 deg.C, 24 hours, 1 time

The products shall be baked on the heat-resistant tray because the material (Base Tape, Reel Tape and Cover Tape) are not heat-resistant.

- The product shall be stored in non corrosive gas (Cl₂, NH₃, SO₂, No_x, etc.).
- Solderability shall be confirmed before use if the product is stored for more than 3 months.
- When the indicator in the packing has changed its color, the product shall be baked before soldering.
- Any excess mechanical shock including, but not limited to, sticking the packing materials by sharp object and dropping the product, shall not be applied in order not to damage the packing materials.

2. Handling Conditions:

- Be careful in handling or transporting products because excessive stress or mechanical shock may break products due to the nature of ceramics structure.
- Handle with care because the characteristics of products may change if products may have cracks or damages on their terminals. Do not touch products with bare hands that may result in poor solderability.

3. Standard PCB Design (Land Patterns and Dimensions) :

- All the ground terminals should be connected to the ground patterns. Please refer to Fig.2 for the standard land dimensions.
- The recommended land patterns and dimensions are as Murata's standard. The characteristics of products may vary depending on the pattern drawing method, grounding method, land dimensions, land forming method of the NC terminals and the PCB material and thickness. Therefore, be sure to verify the characteristics in the actual set. When using non-standard lands, contact Murata beforehand.

4. Notice for Chip Placer :

- When placing products on the PCB, products may be stressed and broken by uneven forces from a worn-out chucking locating claw or a suction nozzle. To prevent products from damages, be sure to follow the specifications for the maintenance of the chip placer being used. For the positioning of products on the PCB, be aware that mechanical chucking may damage products.

5. Soldering Conditions :

- Carefully perform preheating so that the temperature difference (ΔT) between the solder and products surface should be in the following range. When products are immersed in solvent after mounting, pay special attention to maintain the temperature difference within 100 deg.C. Soldering must be carried out by the above mentioned conditions to prevent products from damage. Contact Murata before use if concerning other soldering conditions.

Soldering methods	Temperature
Soldering iron method	$\Delta T \leq 130 \text{ deg.C}$
Reflow method	

- Soldering iron method conditions are indicated below.

Kind of iron	Nichrome heater	Ceramic heater
Items		
Soldering iron wattage	$\leq 30 \text{ W}$	$\leq 18 \text{ W}$
Temperature of iron-tip	$\leq 280 \text{ deg.C}$	$\leq 250 \text{ deg.C}$

- Diameter of iron-tip : 3.0 mm max.
- Do not touch the module itself directly by the iron-tip.

Reflow soldering standard conditions(Example)

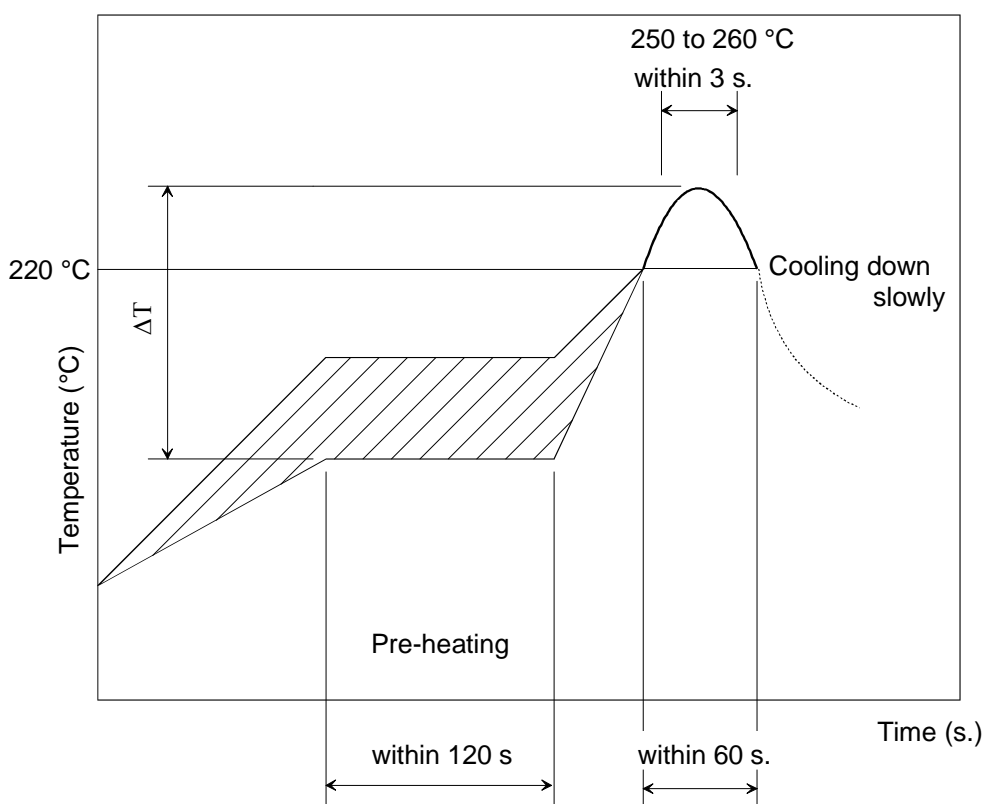

- Use rosin type flux or weakly active flux with a chlorine content of 0.2 wt% or less. Be careful so as not to remain the flux residue around products. Because there are possibilities to become worse the characteristics.

- Amount of Solder Paste:

Ensure that solder is applied smoothly to a minimum height of 0.2 to 0.5 mm at the end surface of the external electrodes. If too much or little solder is applied, there is high possibility that the mechanical strength will be insufficient, creating the variation of characteristics.

Amount of solder paste

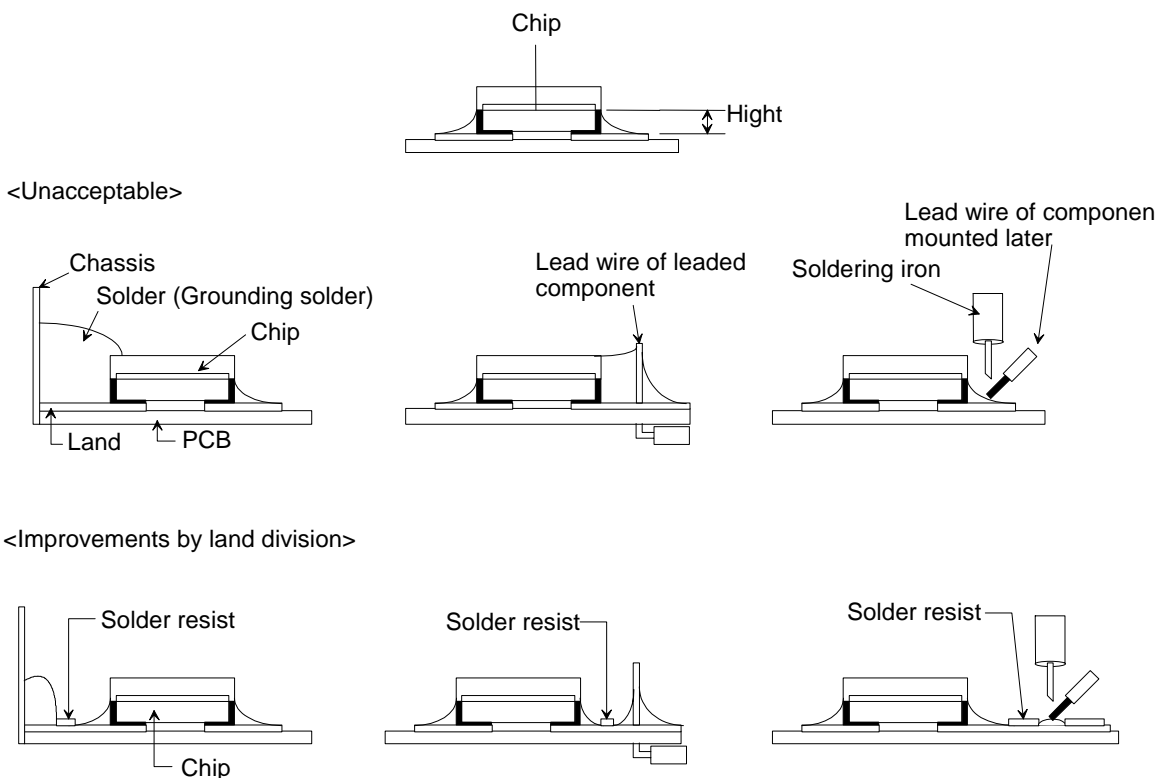

6. Operational Environment Conditions :

- Products are designed to work for electronic products under normal environmental conditions (ambient temperature, humidity and pressure). Therefore, products have no problems to be used under the similar conditions to the above-mentioned. However, if products are used under the following circumstances, it may damage products and electric shock and abnormal temperature may occur.
 - In an atmosphere containing corrosive gas (CL₂, NH₃, SO_x, NO_x, etc.).
 - In an atmosphere containing combustible and volatile gases.
 - Dusty place.
 - Direct sunlight place.
 - Water splashing place.
 - Humid place where water condenses.
 - Freezing place.
- If there are possibilities for products to be used under the preceding clause, consult with Murata before actual use.
- As it might be a cause of degradation or destruction to apply static electricity to products, do not apply static electricity or excessive voltage while assembling and measuring.

7. Limitation of Applications :

Please contact Murata before using products for the applications listed below which require especially high reliability for the prevention of defects which might directly cause damage to the third party's life, body or property.

- Aircraft equipment.
- Aerospace equipment.
- Undersea equipment.
- Medical equipment.
- Transportation equipment (vehicles, trains, ships, etc.).
- Traffic signal equipment.
- Disaster prevention / crime prevention equipment.
- Data-processing equipment
- Application of similar complexity and/ or reliability requirements to the applications listed in the above.



Note :

- Please make sure that your product has been evaluated and confirmed against your specifications when our product is mounted to your product.

- All the items and parameters in this product specification have been prescribed on the premise that our product is used for the purpose, under the condition and in the environment agreed upon between you and us. You are requested not to use our product deviating from such agreement.

- We consider it not appropriate to include other terms and conditions for transaction warranty in product specifications, drawings or other technical documents. Therefore, even if your original part of this product specification includes such terms and conditions as warranty clause, product liability clause, or intellectual property infringement liability clause, we are not able to accept such terms and conditions in this product specification unless they are based on the governmental regulation or what we have agreed otherwise in a separate contact. We would like to suggest that you propose to discuss them under negotiation of contract.