

CMOS LSI FOR 12 lines × 24 columns CHARACTER DISPLAY ON SCREEN

DESCRIPTION

μPD6451 is the CMOS LSI for on-screen character display that can be used in combination with a microcomputer to display time, channel numbers, and chapter numbers on the screen.

Use of this LSI for the video camera and VTR allows recording of video signals with the time and date.

The display character format is 12 x 18 dots. Because there is no space between characters, this LSI enables display of a combination of two or more characters, kanji characters, and graphs.

Both μPD6451CX-001 and μPD6451GT-101 display the same number of characters. μPD6451CX-001 is enclosed in a 18-pin DIP (Dual In-line Package), while μPD6451GT-101 is enclosed in a 20-pin SOP (Small Out-line Package).

FEATURES

- Number of characters displayed : 12 lines x 24 columns
- Number of character types : 128
- Character size : Any one of 1H, 2H, 3H, and 4H per dot can be selected.
- Character color : Any one of 8 colors can be selected for each character.
- Background : One of No Background, Black fringe, Square Background, or Solid Background can be selected for each image. (For Square Background and Solid Background, any one of eight colors can be selectable.)
- Dot matrix : 12-by-18 dot pattern with no space between characters.
- Blink : Selectable at 1:1, 3:1, or 1:3.
- Mask pulse (Code Option) : To be output in vertical direction for each line.
- Double-speed scan TV mode (Switching Command) : Switching of the vertical-scan lines counter adapts to a system in which one field contains 525 scan lines.
- Interface with microprocessor : 8-bit serial input format
- Power supply : +5 V single power supply
- Construction : Low-power-consumption CMOS

ORDERING INFORMATION

PART NUMBER	PACKAGE
μPD6451CX-001	18-pin plastic DIP (300 mil)
μPD6451GT-101	20-pin plastic SOP (375 mil)

BLOCK DIAGRAM

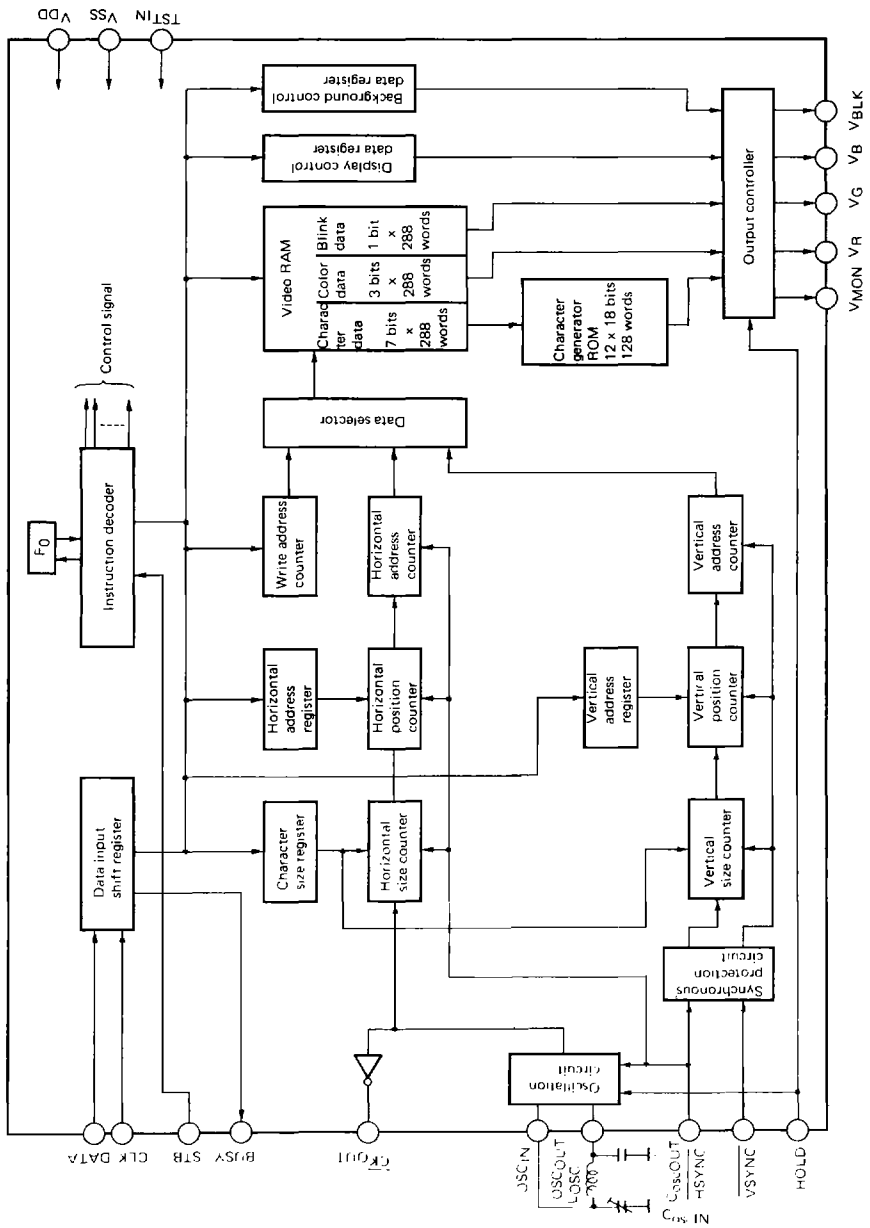

ABSOLUTE MAXIMUM RATINGS (T_a = 25 °C)

Supply Voltage	V _{DD} -V _{SS}	7.0	V
Input Voltage	V _{IN}	V _{DD} + 0.3 > V _{IN} > V _{SS} - 0.3	V
Output Voltage	V _{OUT}	V _{DD} + 0.3 > V _{OUT} > V _{SS} - 0.3	V
Operating Temperature	T _{opt}	-20 to +75	°C
Storage Temperature	T _{stg}	-40 to +125	°C
Output Current	I _O	±5	mA

RECOMMENDED OPERATING RANGE

ITEM	SYMBOL	MIN.	TYP.	MAX.	UNIT
Supply Voltage	V _{DD} - V _{SS}	4.5	5.0	5.5	V
Oscillation Frequency	f _{osc}	4.5		7.0 (12) ^{Note}	MHz

Note: The parenthesized value in the double-speed mode.

ELECTRICAL CHARACTERISTICS

(T_a = 25 °C, V_{DD} = 5.0 V, V_{SS} = 0 V, L_{osc} = 39/56 μH, C_{osc OUT} = 30 pF, C_{osc IN} = 5 to 30 pF)

CHARACTERISTIC	SYMBOL	MIN.	TYP.	MAX.	UNIT	TEST CONDITION
Supply Voltage	V _{DD} - V _{SS}	4.5	5.0	5.5	V	
Current Consumption	I _{DD}			10	mA	
Control Input High Level Voltage	V _{IH}	2.4			V	
Control Input Low level Voltage	V _{IL}			0.8	V	
Synchronous Signal Input High level Voltage	V _{IH}	2.4			V	
Synchronous Signal Input Low level Voltage	V _{IL}			0.8	V	
Signal Output High level Voltage	V _{QH}	4.5			V	I _{OH} = -1.0 mA
Signal Output Low level Voltage	V _{OL}			0.5	V	I _{OL} = 1.0 mA
Clock Output High level Voltage	V _{OH}	4.5			V	I _{OH} = -0.5 mA
Clock Output Low level Voltage	V _{OL}			0.5	V	I _{OL} = 0.5 mA
Hold Signal Input High level Voltage	V _{HHOLD}	4.5			V	
Hold Signal Input Low level Voltage	V _{LHOLD}			2.5	V	

Note Control input DATA, CLK, STB
 Synchronous signal input HSYNC, VSYNC
 Signal output VR, VG, VB, VBLK, VMON, BUSY
 Clock output CKOUT
 Hold signal input HOLD

CONNECTION DIAGRAM (Top View)

(1) μPD6451CX

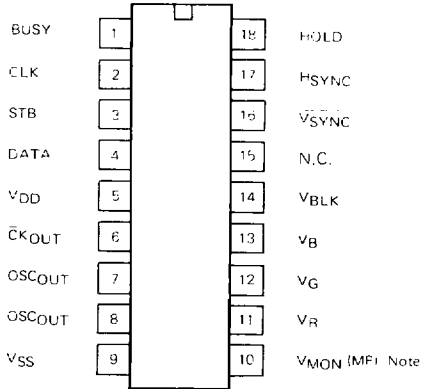

(2) μPD6451GT

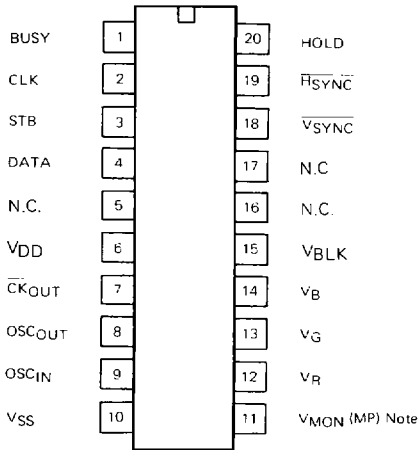

Note:

Pin 10 (μPD6451CX) or 11 (μPD6451GT) within parentheses is the mask code option to be used as the mask pulse. However, μPD6451CX-001/μPD6451GT-101 does not use the mask pulse, so pin 10 or 11 is used as monitor output VMON.

PIN DESCRIPTION

SYMBOL	PIN NAME	FUNCTION
V _{DD}	Power supply terminal	This terminal supplies +5 V power.
V _{SS}	Grounding terminal	This is connected to the system GND.
DATA	Serial data input terminal	This terminal inputs control data. It reads data synchronizing with the clock input to the CLK terminal.
CLK	Clock input terminal	This terminal inputs the clock for reading data. At the rise of this clock, the data input to the DATA terminal is read.
STB	Strobe input terminal	This terminal inputs the strobe pulse after input of serial data. The 8-bit data is read at the rise of the strobe pulse input to the STB terminal. If the 8-bit data is a character, the data address is incremented by 1 at the fall of the strobe pulse.
OSC _{IN} OSC _{OUT}	Oscillation terminals	These terminals are connected to the oscillation capacitor or coil.
H _{SYNC}	Horizontal synchronous signal input terminal	This terminal inputs the horizontal synchronizing signal. The oscillator oscillates when this signal is high, synchronizing with the rise of the signal. Be sure to input the horizontal synchronizing signal when it is active low.
V _{SYNC}	Vertical synchronizing signal input terminal	This terminal inputs the vertical synchronizing signal. Be sure to input this signal when it is active low.
V _R V _G V _B	Character signal output terminals	These terminals output the character data corresponding to R, G, and B.
V _{BLK}	Blanking signal output terminal	This terminal outputs the blanking signal to cut the video signal.
CK _{OUT}	Clock output terminal	This is the inverted output of OSC OUT. To connect another type of on-screen IC in parallel, be sure to connect this terminal to OSCIN of the IC.
HOLD	Hold terminal	Oscillation stops when this signal is low. At this time, the signals output from V _R , V _G , V _B , and V _{BLK} all become low. (Be sure to normally set this signal high.)
BUSY	Data input enable terminal	Output terminal to notify the microcomputer that data is enabled or disabled for input. Data can be input at a low level.
V _{MON} ^{Note}	Character signal output monitor terminal	If any of character signal outputs V _R , V _G , and V _B is High, the high-level signal is output.

Note:

The mask code option enables this terminal to be used as the mask pulse output terminal.

However, μPD6145C-001/μPD6145G-101 does not use the mask pulse, so pin 10 or 11 is used as monitor output V_{MON}.

Command Format

All the control commands are in 8-bit serial input format.

Each control command is executed when a strobe pulse is input after 8-bit data has been input.

Before starting the program, be sure to input the format reset command ("FR = 1", set by the format selection command) to release the test mode.

μPD6451CX-xxx/6451GT-xxx Command List

Content	F ₀	D ₇	D ₆	D ₅	D ₄	D ₃	D ₂	D ₁	D ₀
Display character data	0	0	C ₆	C ₅	C ₄	C ₃	C ₂	C ₁	C ₀
Color blink data for each character	0	1	0	0	0	Blink	R	G	B
Character display line address	0	1	0	0	1	AR ₃	AR ₂	AR ₁	AR ₀
Character display column address	0	1	0	1	AC ₄	AC ₃	AC ₂	AC ₁	AC ₀
Background specification	0	1	1	0	BS ₄	BS ₃	R _b	C _b	B _b
Blink, oscillation, Display ON/OFF	0	1	1	1	0	D ₀	BL ₂	BL ₁	OGC
Fringing Control	0	1	1	1	1	0	0	E ₀₁	E ₀₂
Format selection	X	1	1	1	1	1	1	F ₀	FR
Display position vertical address, Double-speed selector	1	0	1	V _D	V ₄	V ₃	V ₂	V ₁	V ₀
Display position horizontal address	1	1	1	0	H ₄	H ₃	H ₂	H ₁	H ₀
Character size specification <small>Note</small>	1	1	0	S ₅	S ₄	AR ₃	AR ₂	AR ₁	AR ₀
Test mode setting	1	1	1	1	0	T ₃	T ₂	T ₁	T ₀

Note:

Change of a command by using a mask pulse (mask code option).

If the mask code option allows pin 10 (6451CX) or 11 (6451GT) to be used as the mask pulse output terminal (MPI), the character size specification command is changed as follows and used as the mask pulse selection command. (The number of selectable character sizes is changed from 4 to 2.)

Content	F ₀	D ₇	D ₆	D ₅	D ₄	D ₃	D ₂	D ₁	D ₀
Character size/mask pulse	1	1	0	MP	S ₄	AR ₃	AR ₂	AR ₁	AR ₀

Format Selection/Reset (Test Mode Releasing)

The μ PD6451 commands consist of 9 bits, but the shift registers for serial interfacing with external units consist of 8 bits. Therefore, instructions are divided into two banks. One of these banks is selected by one bit of the format selection command.

Bank-0 commands ($F_0 = 0$)

- Display character data
- Color/blink data for each character
- Character display line address
- Character display column address
- Background specification
- Blink, Oscillation control, Display ON/OFF
- Fringing control

Bank-1 commands ($F_0 = 1$)

- Vertical display position address, Double-speed selector
- Horizontal display position address
- Character size specification

Format Reset (Test Mode Releasing)

When bit 1 (FR) of the format reset command is set to "1", the test command mode is released to reset the contents of the following command. A normal command cannot be accepted in the test command mode. Therefore, be sure to release the test command mode by resetting the format before starting the program.

Command to Be Reset

The contents of all the line size registers (AR_{0-3}) are set to (S_5, S_4) = (0, 0).

[All the lines are specified in the minimum size.]

If the mask option allows pin 10 (μ PD6451CX) or pin 11 (μ PD6451GT) to be used as the mask pulse output terminal, the contents of all the line size registers (AR_{0-3}) are set to " $(S_4) = (0)$ " to disable the mask pulse output from any line. (MP) = (0).

To release the test command mode without resetting the above command, use the test command mode release instruction ($F_0, D_7, D_6, D_5, D_4, D_3, D_2, D_1, D_0$) = (1, 1, 1, 1, 0, 0, 0, 0, 0).



Format Selection Command

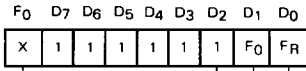

Format reset bit (Not latched)	
F _R	Function
1	Release the test mode and resets the contents of the character size selection command.

BANK selector bit	
F ₀	Function
0	Allows the use of each Bank-0 command.
1	Allows the use of each Bank-1 command.

Indicates the format selection command.

μPD6451CX-001/6451GT-101 Character Pattern

As shown in the following, μPD6451CX-001/6451GT-101 enables display of 128 character generator ROM patterns. The 128 character generator ROM patterns can be changed by the mask code option. However, character code "7FH" is fixed to the display OFF code so that no character pattern can be input to this code.

μPD6451CX-001 and μPD6451GT-101 have the same character patterns in the character generator ROM though their packages are different.

μPD6451CX-001/6451GT-101 Character Patterns

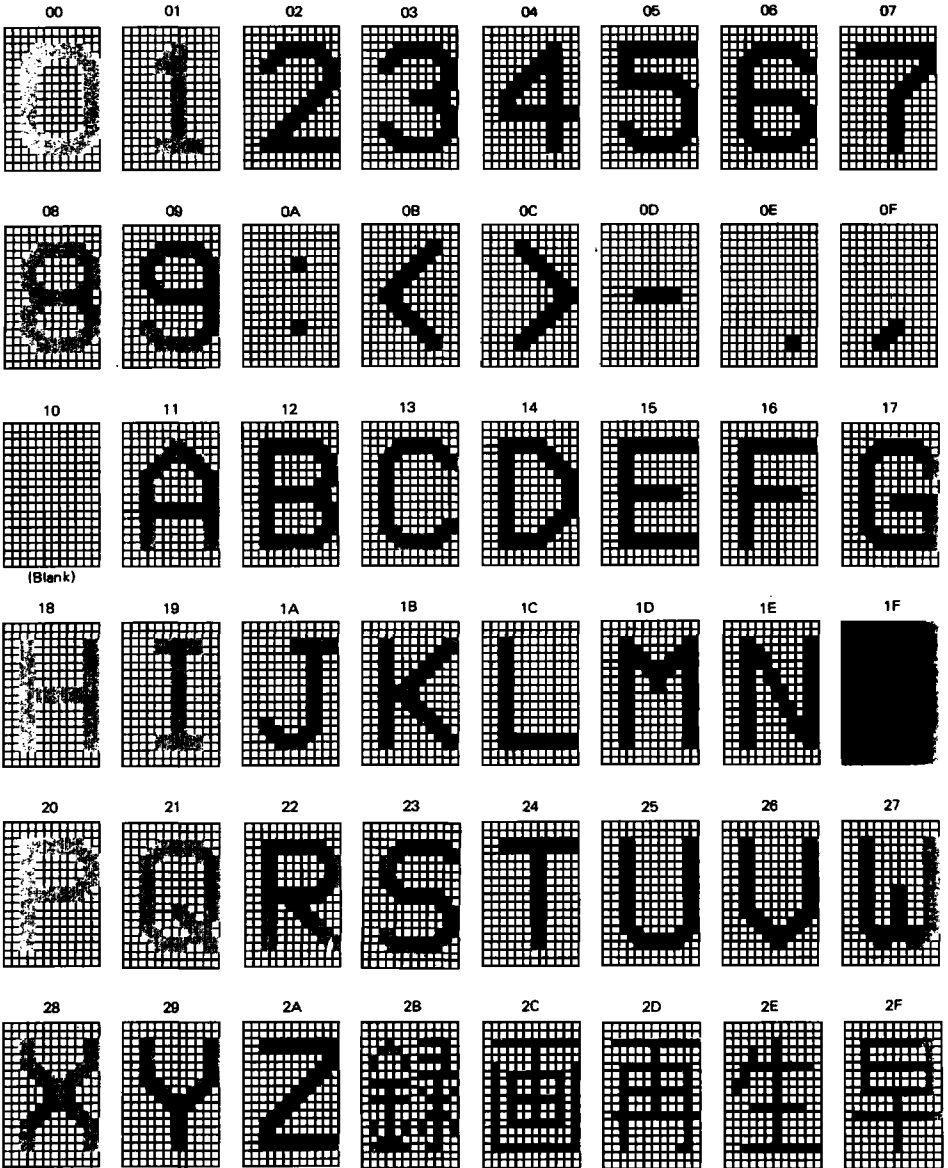

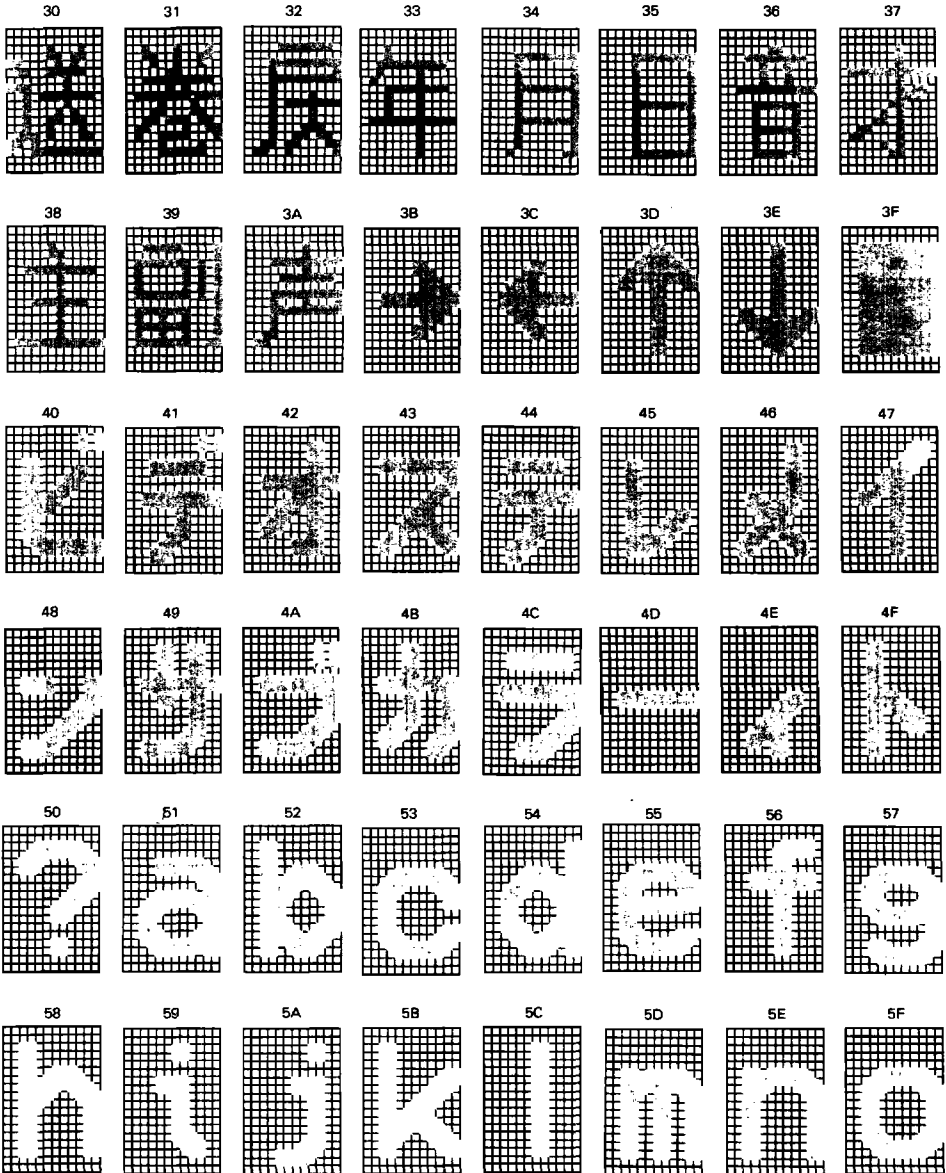

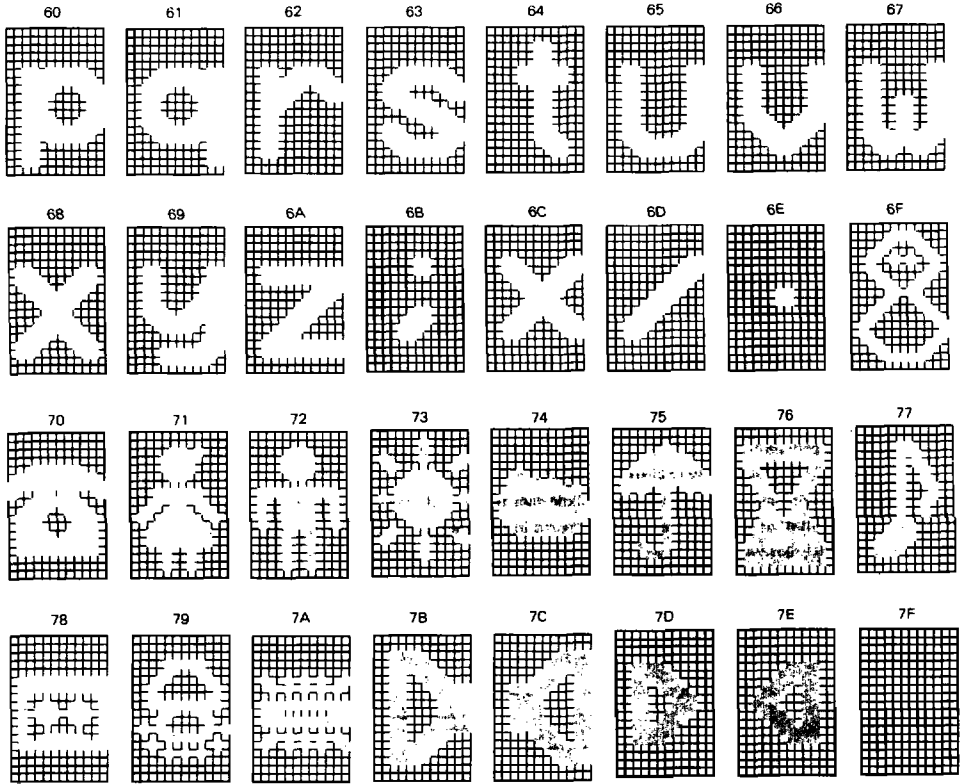

Display off data
(No character pattern
can be entered)

Character Display

The number of characters displayed is 12 lines x 24 columns; that is, 288 as shown below:

ACA, AC3, AC2, AC1, AC0	00000	00001	00010	00011	00100	00101	00110	00111	01000	01001	01010	01011	01100	01101	01110	01111	10000	10001	10010	10011	10100	10101	10110	10111	
AR3 AR2 AR1 AR0	0000																								
	0001																								
	0010																								
	0011																								
	0100																								
	0101																								
	0110																								
	0111																								
	1000																								
	1001																								
	1010																								
	1011																								

Writing of Display Character Data and Color/Blink Data for Each Character

The write address for data can be directly set in the address counter by the character display line address command and the character display column address command.

After the write address is set, the color/blink data for each character is input by the color/blink data command. The color or blink data for each character is saved in the internal register. Then, the display character data is input by the display character data command. At the rise of the STB pulse (to be input at completion of execution of the display character data command), the color/blink data and the display character data, which are saved in the internal register, are written to the video RAM. The write address is incremented as shown below at the fall of the STB pulse when the display character data is input. To write display character data continuously without changing the color/blink data for each character, just input the display character command.

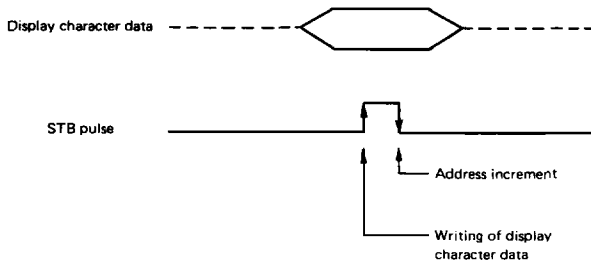

Column address counter AC₄, AC₃, AC₂, AC₁, AC₀

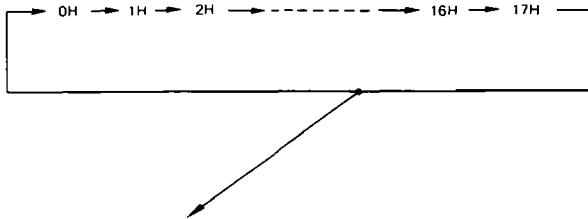

Line address counters AR₃, AR₂, AR₁, AR₀

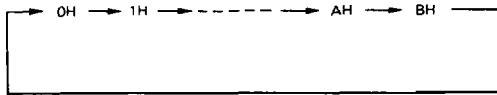

Example: Writing of the following data in lines/columns from line 0/column 0 to line 0/column F

Character color	Blue	Blue	Blue	Blue	Blue	Red	Red	Red	Red	Red	Red	Green	Green	Green	Green	Green
Character blinking	OFF	OFF	OFF	ON	ON	ON	ON	ON	ON	ON	ON	OFF	OFF	OFF	OFF	OFF
Display character	0	1	2	3	4	5	6	7	8	9	9	9	9	9	9	9

- Set line 0 using the character display line address command.
- ↓
- Set column 0 using the character display column address command.
- ↓
- Set "blue" and "blinking off" using the color blink data for each character data command.
- ↓
- Set data "0" using the display character data command.
- ↓
- Set data "1" using the display character data command.
- ↓
- Set data "2" using the display character data command.
- ↓
- Set "blue" and "blinking off" using the color blink data for each character data command.
- ↓
- Set data "3" using the display character data command.
- ↓
- Set data "4" using the display character data command.
- ↓
- Set data "red" and "blinking on" using the color blink data for each character data command.
- ↓
- Set data "5" using the display character data command.
- ↓
- Set data "6" using the display character data command.
- ↓
- Set data "7" using the display character data command.
- ↓
- Set data "8" using the display character data command.
- ↓
- Set data "9" using the display character data command.
- ↓
- Set data "9" using the display character data command.*
- ↓
- Set "green" and "blinking off" using the color blink data for each character data command.
- ↓
- Set data "9" using the display character data command.
- ↓
- Set data "9" using the display character data command.*
- ↓
- Set data "9" using the display character data command.*
- ↓
- Set data "9" using the display character data command.*
- ↓
- Set data "9" using the display character data command.*

*Data can be set by only sending the STB signal without sending 8-bit serial data.

Character Display Line Address Command

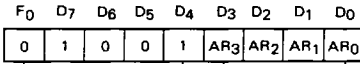

Line addressing bits				Function
AR ₃	AR ₂	AR ₁	AR ₀	
0	0	0	0	Set the 1st line.
0	0	}	0	Set the 2nd line.
1	0		1	1

Do not set an address other than addresses 0H through BH.

Indicates the character display line address command.

Character Display Column Address Command

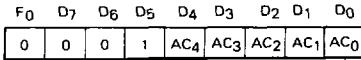

Column addressing bits					Function
AC ₄	AC ₃	AC ₂	AC ₁	AC ₀	
0	0	0	0	0	Set the 1st line.
0	0	}	0	0	Set the 2nd line.
1	0		1	1	1

Do not set an address other than the addresses 0H through 17H.

Indicates the character display column address command.

Color Blink Data for Each Character Command

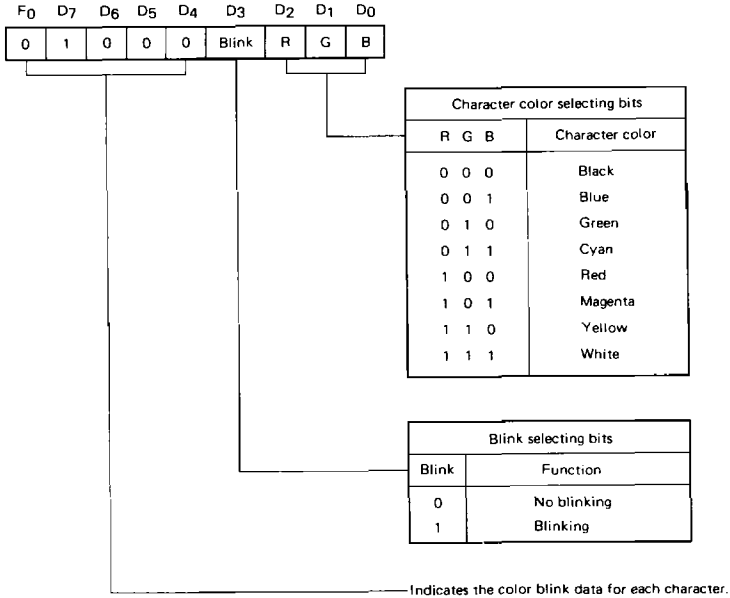

Display Character Data Command

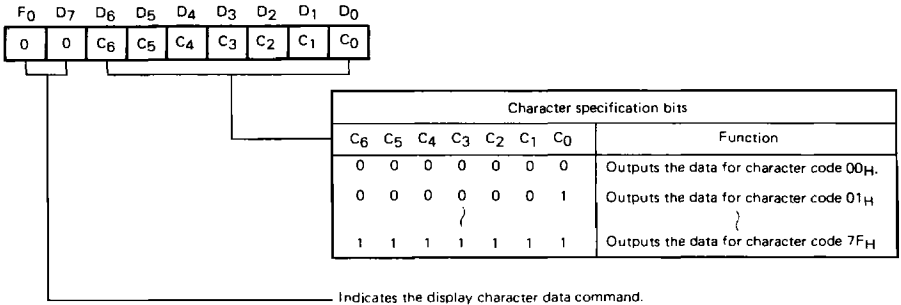

Oscillation Control

This IC allow oscillation to be turned ON/OFF with the blinking/oscillation control command so that it can stop oscillation during the period for displaying no character in order to save power. However, the character output remains executable even after oscillation has been stopped. Therefore, use the display control command in conjunction with this command. And the VRAM cannot be overwritten while oscillation is off.

Character Blinking

This IC allow character-by-character blinking with the blinking/oscillation control command. Use the color blink data for each character command to specify the character or characters to be blinked. Select a blinking ratio of 1:1, 1:3, or 3:1. (A blinking cycle of approximately one second is equivalent to 64 times the vertical cycle.)

Blinking, Oscillation, Display ON/OFF Control Command

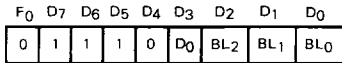

Oscillation control bits	
OSC	Function
0	Oscillation OFF
1	Oscillation ON

Blinking control bits		
BL ₂	BL ₁	Function
0	0	Blinking OFF
0	1	ON 1 OFF 3
1	0	ON 3 OFF 1
1	1	ON 1 OFF 1

Display ON/OFF control bits	
DO	Function
0	Display OFF
1	Display ON

Indicates the blinking, oscillation, display ON/OFF control command



Character Display Address

The character display start address can be determined, as shown below, according to the values specified by the display position vertical address Double-speed selector command ($F_0, D_7, D_6, D_5, D_4, D_3, D_2, D_1, D_0$) = (1, 0, 1, $V_D, V_4, V_3, V_2, V_1, V_0$) and the display position horizontal address command ($F_0, D_7, D_6, D_5, D_4, D_3, D_2, D_1, D_0$) = (1, 1, 1, 0, H_4, H_3, H_2, H_1, H_0):

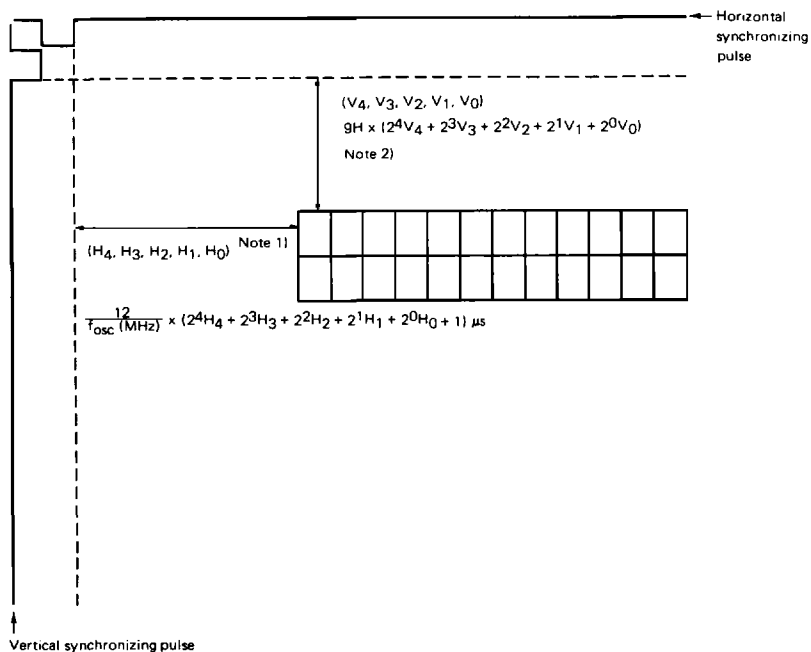

Note 1: 9H is changed to 18H when the double-speed scan TV mode is selected by the double-speed selector command.

Display Position Vertical Address Command

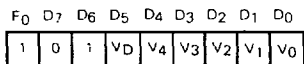

Vertical address assignment bits					
V4	V3	V2	V1	V0	Start address
0	0	0	0	0	From the trailing edge of the vertical synchronizing pulse Note) 9 x 0H
0	0	0	0	1	From the trailing edge of the vertical synchronizing pulse 9 x 1H
1	1	1	1	1	From the trailing edge of the vertical synchronizing pulse 9 x 31H

Double-speed selector bit	
V _D	Function
0	Normal TV
1	Double-speed scan TV

Indicates the command for display position vertical address and double-speed switching.

Display Position Horizontal Address Command

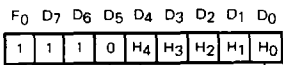

Horizontal address assignment bits					
H4	H3	H2	H1	H0	Start address
0	0	0	0	0	From the trailing edge of the horizontal synchronizing pulse $12/f_{osc}(\text{MHz}) \times 1 [\mu\text{s}]$
0	0	0	1	0	From the trailing edge of the horizontal synchronizing pulse $12/f_{osc}(\text{MHz}) \times 2 [\mu\text{s}]$
1	1	1	1	1	From the trailing edge of the horizontal synchronizing pulse $12/f_{osc}(\text{MHz}) \times 32 [\mu\text{s}]$

Indicates the display position horizontal address command.

Notes: 9H is changed to 18H when the double-speed scan TV mode is selected by the double-speed selector command.

Character Size Specification

As the character size, one dot 2H, 4H, 6H, or 8H can be selected for each line. Use the character size specification command to specify lines and their character sizes.

If, however, the mask pulse function is selected by the mask option, only two character sizes (one-dot 2H and 4H) can be selected. (See the section for the mask pulse.)

Character Size Specification Command

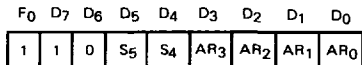

Line address selection bits				
AR ₃	AR ₂	AR ₁	AR ₀	Function
0	0	0	0	Select the 1st line.
0	0	0	1	Select the 2nd line.
))
1	1	0	1	Select the 12th line.

Do not set an address other than addresses 0H through BH.

Character size specification bits			
S ₅	S ₄	Character dot size	
0	0	Vertical 1H	Horizontal t _{dot}
0	1	2H	2 · t _{dot}
1	0	3H	3 · t _{dot}
1	1	4H	4 · t _{dot}

$$t_{dot} = \frac{1}{f_{osc}(\text{MHz})} \mu\text{s}$$

Indicates the character size specification command.

Background Specification

The background type and color can be specified for each image using the background specification command. The background types available are: no background, black fringe, square background, and solid background. The background colors available are: black, blue, green, cyan, red, magenta, yellow, and white.

Background Specification Command

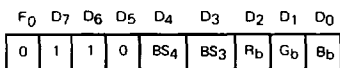

Background color specification bits			
R _b	G _b	B _b	Background color
0	0	0	Black
0	0	1	Blue
0	1	0	Green
0	1	1	Cyan
1	0	0	Red
1	0	1	Magenta
1	1	0	Yellow
1	1	1	White

For no background or black border, set (R_b, G_b, B_b) = (0, 0, 0).

Background format specification bits		
BS ₄	BS ₃	Background format
0	0	No background
1	0	Square background
1	1	Solid background

Note: Do not use (BS₄, BS₃) = (0, 1)

Indicates the background specification command.

Fringing Control Command

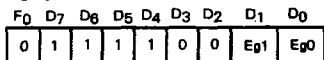



Fringing control bit		
Eg ₁	Eg ₀	Function
0	0	Fringing off
0	1	
1	0	Black fringing
1	1	White fringint

Indicate the fringing control command.

Display format in Each Background Mode

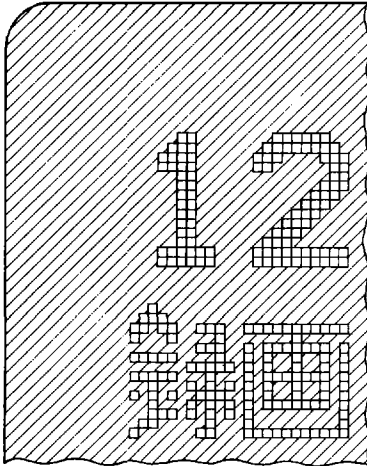

No background



-  Character color
-  Picture

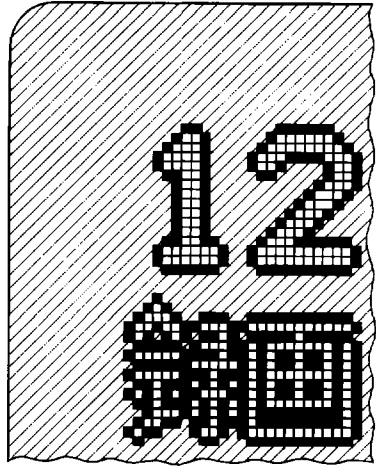

Black or white fringe



-  Character color
-  Black or white fringe
-  Picture

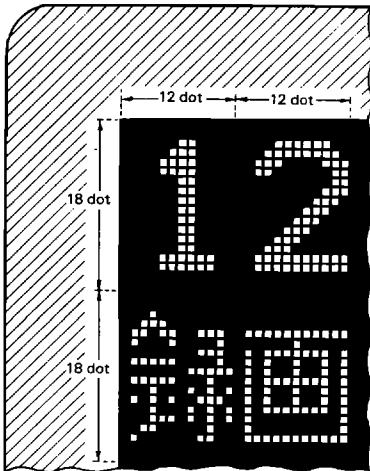

Square background

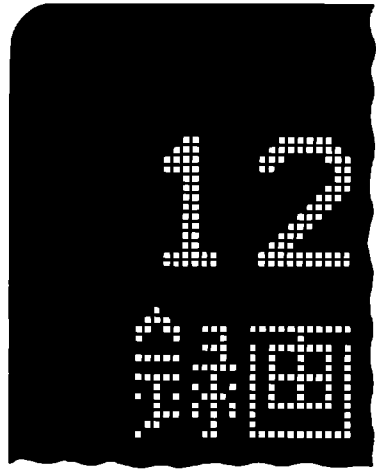

-  Character color
-  Background color
-  Picture

Solid background



-  Character color
-  Background color

Write Control

Data to be displayed is synchronized with the dot clock whether or not characters are being displayed on the screen according to the display on/off command. While the displayed data is being written, the BUSY terminal (terminal 1) becomes high to direct the microcomputer to stop sending data, to prevent the next data from being sent to the external source.

Mask Pulse Function (Mask Code Option)

When used in a VTR camera, the on-screen ICs provide two types of information; information to be recorded on VTR tape, such as the date and title, and information to be displayed only inside the electronic view finder, such as the battery, focus, sensitivity, and mode. For proper use of these two types of information, the mask option allows the V_{MON} terminal to be used as the character-by-character signal output terminal.

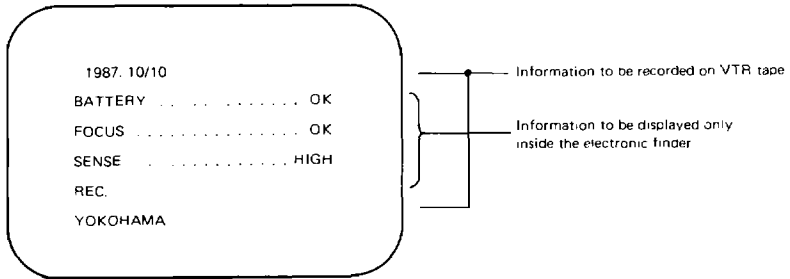

Example: The mask pulse is to be output to line addresses 1H, 3H, and 5H with vertical address 0H and a character size of 1H/dot.

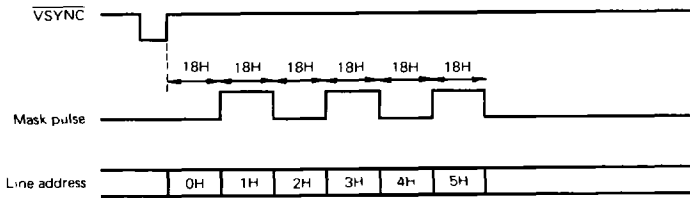

The leading and trailing edges of the mask pulse are synchronized with the trailing edge of $\overline{\text{HSYNC}}$.

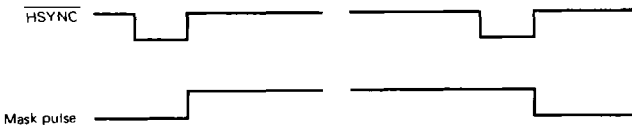

Double-Speed Scan TV Application (Mask Code Option)

In general, if on-screen ICs are used in a television set with a double-speed scanning function, the number of scan lines per field (twice the conventional number) and the time required for horizontal scan (half of the conventional time) are different from those for the conventional NTSC and PAL TV systems.

Character output is doubled in width, halved in height, and halved in time lag with respect to the vertical synchronizing pulse. The character width can be adjusted according to oscillation frequency (but the maximum permissible value of f_{osc} is 7.0 MHz in the case of double-speed scan TV it is 10.0 MHz), but neither the character height nor the vertical position can be changed because they are automatically determined by the number of horizontal lines.

The μ PD6145 is therefore designed so that the character height and vertical position can be changed by inserting a single stage of 1/2-cycle dividers in the vertical address counter section using a mask code option. This, however, involves the following changes to the display-position vertical address assignment command and the character size specification command.



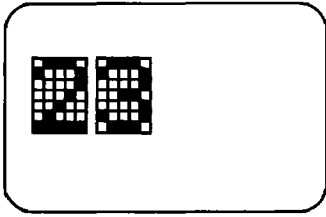

When an on-screen IC is used in a system with one field equivalent to 262.5 H (or 312.5 H).

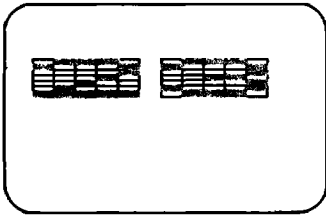

When an on-screen IC is used directly in a system with one field equivalent to 525 H (or 625 H).

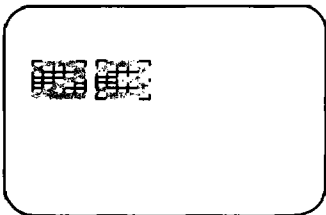

When an on-screen IC with its oscillation frequency doubled is used in a system with one field equivalent to 525 H (or 625 H).

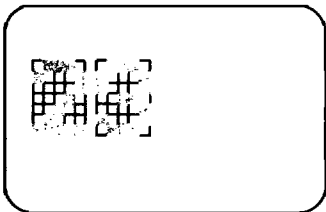

When μ PD6451CX/GT is used in a system applying the double-speed scanning TV mode with a mask option.

Display-Position Vertical Address Assignment Command

(Available only when the system is set in a double-speed scanning TV mode by mounting a mask code option)

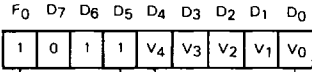

Vertical address specification bits					Start address
V4	V3	V2	V1	V0	
0	0	0	0	0	From the tailing edge of the vertical synchronizing pulse 18 x 0H
0	0	0	0	1	From the trailing edge of the vertical synchronizing pulse 18 x 1H
}					}
1	1	1	1	1	From the trailing edge of the vertical synchronizing pulse 18 x 31H

Indicates the display-position vertical address assignment command.

Note: Neither the μPD6451CX-001 nor μPD6451GT-101 are optional in the double-speed scanning TV mode.

Character Size Specification Command

(Available only when the system is set in double-speed scanning TV mode)

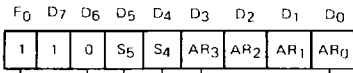

Line address selection bits				Function
AR3	AR2	AR1	AR0	
0	0	0	0	Select the 1st line
0	0	0	1	Select the 2nd line
		}		}
1	0	1	1	Select the 12th line

Do not set an address other than addresses 0H through BH

Character size specification bits		Character dot size	
S5	S4		
0	0	Vertical 2H	Horizontal t dot
0	1	4H	2 t dot
1	0	6H	3 t dot
1	1	8H	4 t dot

$$t_{dot} = \frac{1}{f_{osc}(\text{MHz})} = \mu\text{s}$$

Indicates the character size specification command.

RECOMMENDED CONDITIONS FOR OPERATION TIMING

($T_a = 25^\circ\text{C}$, $V_{DD} - V_{SS} = 5.0\text{ V}$)

ITEM	SYMBOL	CONDITION	MIN.	TYP.	MAX.	UNIT
Minimum setup time	$t_{D\phi}$		200			ns
Minimum hold time	$t_{\phi D}$		200			ns
Minimum clock width at low level	$t_{\phi WL}$		700			ns
Minimum clock width at high level	$t_{\phi WH}$		700			ns
Minimum clock-to-strobe time	$t_{\phi S}$		400			ns
Minimum strobe width at high level	t_{SWH}		1			μs
Clock cycle	$t_{\phi CY}$		1.6			μs
Minimum strobe-to-clock time	$t_{B\phi}$	During display OFF	100			ns
Minimum VSYNC width at low level	t_{VWL}		4			μs
Minimum HSYNC width at high level	t_{HWL}		4			μs

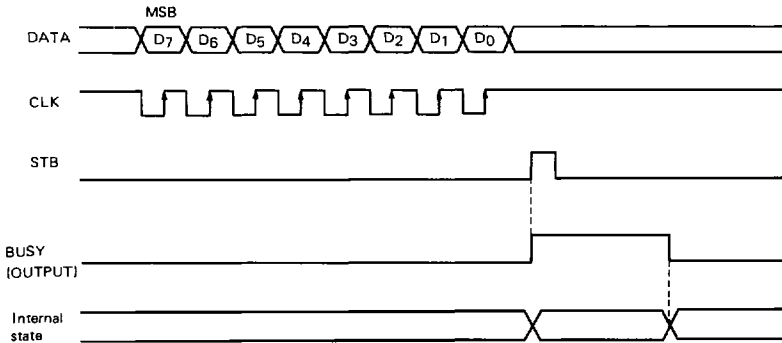

For format data, the BUSY signal goes low after the internal state is completely established. It also goes low when writing data into the VRAM is finished.

When writing data into the VRAM extends to the horizontal flyback time, the BUSY signal lasts longer than usual. (This is because oscillation is off and data cannot be written into the VRAM during the horizontal flyback time.)

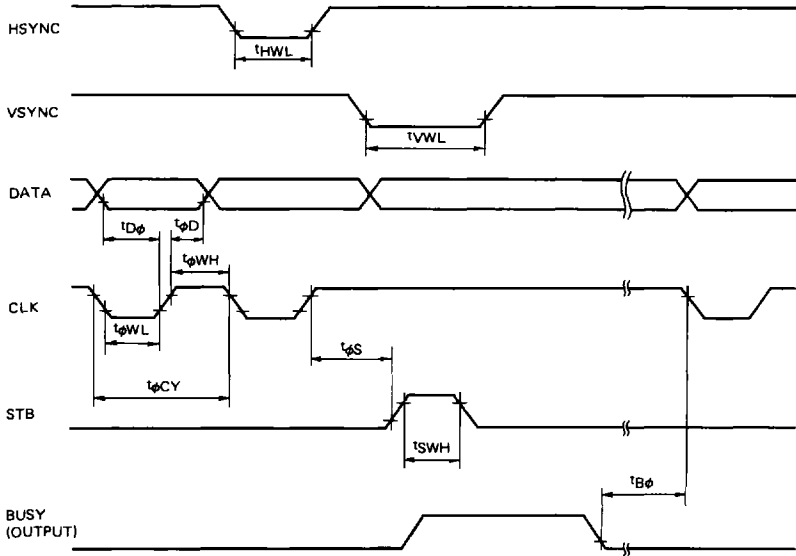

APPLICATION CIRCUIT CONFIGURATION

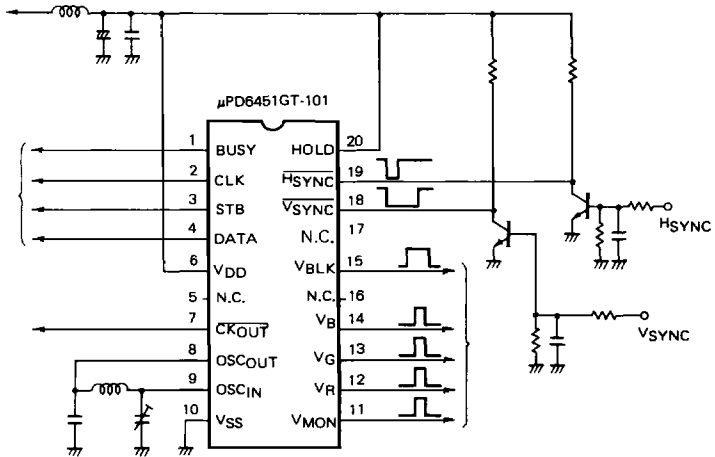
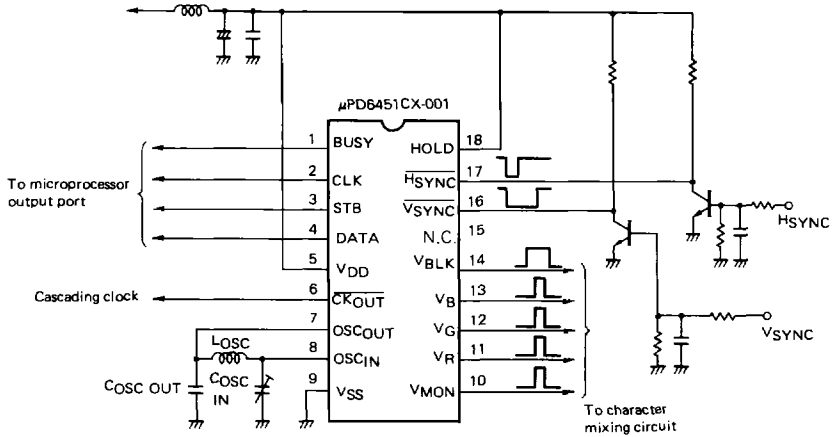

μPD6451CX-001

18-pin plastic DIP (300 mil)

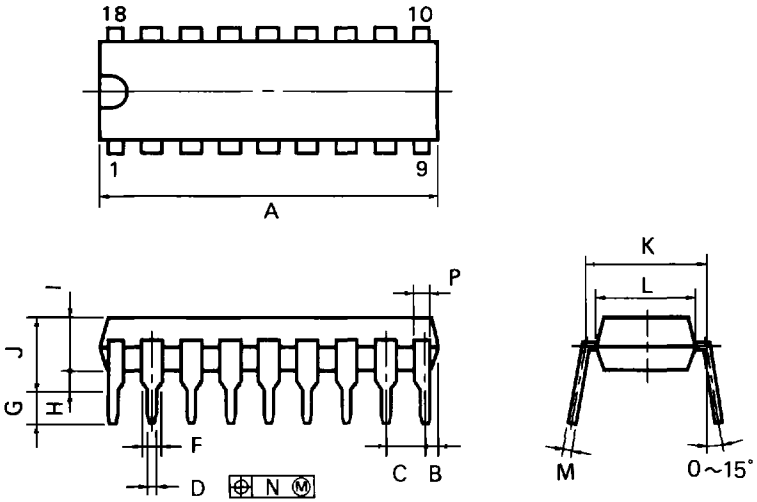

P18C-100-300B

NOTES

- 1) Each lead centerline is located within 0.25 mm (0.01 inch) of its true position (T.P.) at maximum material condition.
- 2) Item "K" to center of leads when formed parallel.

ITEM	MILLIMETERS	INCHES
A	22.86 MAX.	0.900 MAX.
B	1.27 MAX.	0.050 MAX.
C	2.54 (T.P.)	0.100 (T.P.)
D	0.50 ^{+0.10}	0.020 ^{-0.004}
F	1.2 MIN.	0.047 MIN.
G	3.2 ^{+0.3}	0.126 ^{+0.012}
H	0.51 MIN.	0.020 MIN.
I	4.31 MAX.	0.170 MAX.
J	5.08 MAX.	0.200 MAX.
K	7.62 (T.P.)	0.300 (T.P.)
L	6.4	0.252
M	0.25 ^{+0.10}	0.010 ^{-0.004}
N	0.25	0.01
P	1.0 MIN.	0.039 MIN.

μPD6145GT-101

20-pin plastic SOP (375 mil)

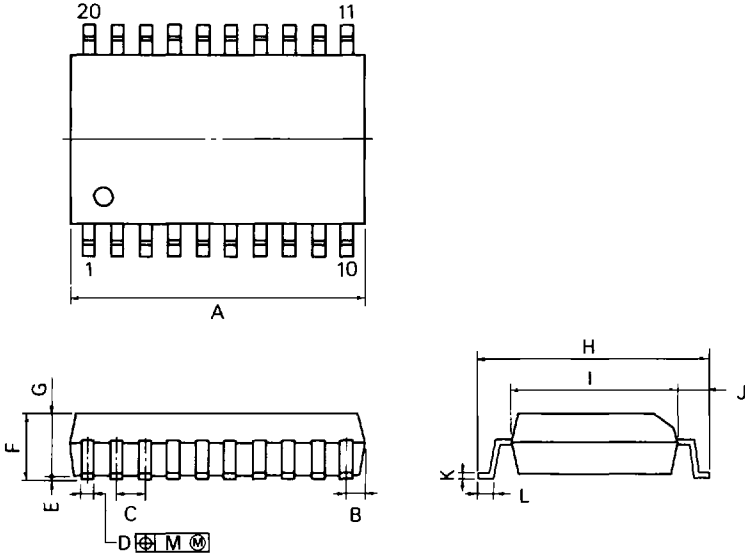

P20GM-50-375B

NOTE

Each lead centerline is located within 0.12 mm (0.005 inch) of its true position (T.P.) at maximum material condition.

ITEM	MILLIMETERS	INCHES
A	13.00 MAX.	0.512 MAX.
B	0.78 MAX.	0.031 MAX.
C	1.27 (T.P.)	0.050 (T.P.)
D	0.40 ^{-0.010} / _{0.05}	0.016 ^{-0.004} / _{0.003}
E	0.1 ^{-0.02} / _{0.1}	0.004 ^{-0.008} / _{0.004}
F	2.9 MAX.	0.115 MAX.
G	2.50	0.098
H	10.3 ^{-0.3} / _{0.3}	0.406 ^{-0.013} / _{0.013}
I	7.2	0.283
J	1.6	0.063
K	0.15 ^{-0.05} / _{0.05}	0.006 ^{-0.004} / _{0.002}
L	0.8 ^{-0.2} / _{0.2}	0.031 ^{-0.008} / _{0.008}
M	0.12	0.005