

PM8354 & PM8354A

QuadPHY[®] 1G

**4 CHANNEL PHYSICAL LAYER TRANSCEIVER WITH
GIGABIT ETHERNET PCS AND TRUNKING FOR
933 Mbit/s TO 1.25 Gbit/s INTERFACES**

Data Sheet

Released

Issue No. 6: November 2005

Legal Information

Copyright

Copyright 2005PMC-Sierra, Inc. All rights reserved.

The information in this document is proprietary and confidential to PMC-Sierra, Inc., and for its customers' internal use. In any event, no part of this document may be reproduced or redistributed in any form without the express written consent of PMC-Sierra, Inc.

PMC-2012433 (R6)

Disclaimer

None of the information contained in this document constitutes an express or implied warranty by PMC-Sierra, Inc. as to the sufficiency, fitness or suitability for a particular purpose of any such information or the fitness, or suitability for a particular purpose, merchantability, performance, compatibility with other parts or systems, of any of the products of PMC-Sierra, Inc., or any portion thereof, referred to in this document. PMC-Sierra, Inc. expressly disclaims all representations and warranties of any kind regarding the contents or use of the information, including, but not limited to, express and implied warranties of accuracy, completeness, merchantability, fitness for a particular use, or non-infringement.

In no event will PMC-Sierra, Inc. be liable for any direct, indirect, special, incidental or consequential damages, including, but not limited to, lost profits, lost business or lost data resulting from any use of or reliance upon the information, whether or not PMC-Sierra, Inc. has been advised of the possibility of such damage.

Trademarks

For a complete list of PMC-Sierra's trademarks and registered trademarks, visit:
<http://www.pmc-sierra.com/legal/> .

Patents

Granted

The technology discussed in this document is protected by one or more of the following patent grants:

U.S. Patent No. 6,316,977B1, 6,552,619

Contacting PMC-Sierra

PMC-Sierra
100-2700 Production Way
Burnaby, BC Canada V5A 4X1

Tel: +1 (604) 415-6000
Fax: +1 (604) 415-6200

Document Information: document@pmc-sierra.com
Corporate Information: info@pmc-sierra.com
Technical Support: apps@pmc-sierra.com
Web Site: <http://www.pmc-sierra.com>

Revision History

Issue No.	Issue Date	Details of Change
1	July 2001	Initial release.
2	June 2002	<p>Grammar & spelling corrections</p> <p>Changed Issue from 1 to 2 and date from September to January 2002</p> <p>Changed Device Status from Preview to Advanced</p> <p>Deleted pending patents in Patents Section</p> <p>Changed references to QuadPHY and OctaPHY from Engineering Document to Data Sheet.</p> <p>Removed PMC-2001507, Enhanced-LVDS (ELVDS) Electrical Specification from Reference Section.</p> <p>Removed PMC-2010750, SINGAL INTEGRITY FOR PMC-SIERRA 3.125/2.488/1.5Gbit/s LINKS from Reference Section.</p> <p>Removed document links from Reference Section.</p> <p>Updated Pin Diagram.</p> <p>Updated Pin Descriptions.</p> <p>Added TEST_EN pin.</p> <p>General Document Cleanup.</p> <p>Added sections 10 through 19.</p> <p>Replaced PCS State Diagrams with reference to IEEE specification.</p> <p>Removed Patent Heading</p> <p>Compacted and rephrased - Chapter 2 Features</p> <p>Modified – Chapter 3 Applications</p> <p>Corrected Diagram from 10GE text on line card to 8xGE text</p> <p>Chapter 5.2 Applications – deleted mode specific applications and replaced with generic protocol model application.</p> <p>Installed Thermal Information</p> <p>Added Mechanical Drawing</p> <p>Removed optional implementation marking in the Auto-negotiation State Machine diagram.</p> <p>Updated pin descriptions for RXDA[0:9], RXDB[0:9], RXDC[0:9], RXDD[0:9], TXCKA, TXDA[0:9], TXCKB, TXDB[0:9], TXCKC, TXDC[0:9], TXCKD, TXDD[0:9]</p> <p>Reworded transmit FIFO description for clarity regarding deviation of phase relationship</p> <p>Updated Trunking Mode description in Section 10.1.2</p> <p>Added figure and associated text: Simulation Results for 6" Trace and 5 pf Load</p> <p>Added information to Section 13.3 – High-speed Serial Interface</p> <p>Updated Reference Clock Timing data</p> <p>Changed default values for bits 7-10 in PMC Test Register 2 definition.</p> <p>Replaced references to CVDISEN with CODE_VIOL_DIS_ENABLE.</p> <p>Added SYNC_ERR_CODE_EN bit description to Bit 3 of the PMC Control 3 Register.</p>

		<p>Updated MDC/MDIO Read Cycle Figure so that Opcode is 10.</p> <p>Added information in MDC/MDIO Interface section that describes the need for a preamble when a code error occurs.</p> <p>Added sentence in MDC pin description that states a clock must be present on REFCLK for the MDC/MDIO interface to work properly.</p> <p>Replaced references to INSERTA with INSERT_A_CHAR.</p> <p>Replaced references to ACHAR_EN with A_CHAR_EN.</p> <p>Updated LINK_STATUS and REMOTE_FAULT pin descriptions and type in register table.</p> <p>Updated IPG description to Receive FIFO Section.</p> <p>Added text to clarify "Alignment Character insertion during IPG" description to Receive FIFO Section.</p> <p>Updated A_DELAY bit description.</p> <p>Added note to REFCLK to TXCKy AC timing Spec. to clarify description.</p> <p>Added max fall time spec on RESET AC timing Spec.</p> <p>Added max rise time spec on TRSTB AC timing Spec.</p> <p>The MDC/MDIO rise and fall times have been changed to max and "Input" has been added to the MDIO rise and fall time description.</p> <p>Added TzMDIO spec of 10ns.</p> <p>The JTAG spec is called out in the reference section. The MDC/MDIO interface is called out in Clause 22 of the 802.3 Spec.</p> <p>Changed Unit from UI in jitter specification to UI pk-pk.</p> <p>Changed absolute maximum voltage rating on digital inputs and bi-directional pins Absolute Maximum Ratings section.</p> <p>Changed Type from R/W to R on the reserved bits in the following registers 0x10, 0x12, 0x13, 0x14, 0x15.</p> <p>Added AC timing to Parallel Interface section for 106MHz.</p> <p>Added bit definition table to the INT_MODE_SEL[1:0] bit description in register 0x11.</p> <p>Added bit definitions to test bits [15:12] of the Redundancy Control Register 0x1D.</p> <p>Updated the description in the Byte Alignment Section.</p> <p>Updated Parallel Loopback Section. Removed local clock remote clock relationship description and added modes that are not supported.</p> <p>Added OUI bit description in the GMII PHY Identifier Register definition.</p> <p>Changed ANSI X3T11 Fibre Channel compliant to ANSI X3T11 Fibre Channel System compliant in General Feature List.</p> <p>Removed optional decoder block from the Receive Data Path HRRC Mode Block Diagram.</p> <p>Added text to HRRC Mode Section that clearly states that the transmitting device is expected to keep track of even and odd-ness for sending commas.</p> <p>Updated Transmit Latency Timing Table to account for the increase in the transmit FIFO's depth.</p>
--	--	---

		<p>Added TMS note to TAP Controller Finite State Machine Figure.</p> <p>Changed item number 5 in the GEMOD pin description. Invalid register location and bit name.</p> <p>Decreased the pk-pk voltage levels of the High Speed differential outputs in the High-speed I/O Characteristics Table.</p>
3	March 2003	<ul style="list-style-type: none"> - Updated Engineering Document to be compliant with Rev. 12 of the ASSP Product Engineering Document. - Updated ISOLATE Bit description. - Updated POWER_DOWN Bit description. - Added text to REFCLK pin description so that it clearly states that the PLL expects an uninterrupted reference clock. - Changed bits in PMC Control Register 1 (0x10) Bit Description Table to read only. - Changed bits in Loopback Control Register (0x16) Bit Description Table to read only. - Changed text in PHYAD Bit Description that referencing number of QuadPHY 1G required for 32 PHYs. Text below Management Interface Frame Format Table. - Updated text in the RRRRC Mode Options section of the Eng Doc to correct bit configuration typo. - Updated detailed Transmit Channel Block Diagram in Transmit Path Section. - Updated detailed Receive Channel Block Diagram in Receive Path Section. - Updated SMRESET pin and SOFT_RESET bit descriptions to indicate that they are ORed together. - Updated REFCLK pin description so that it indicates that the voltage levels are referenced to VDDQ. - Updated descriptions in Byte Alignment and Synchronization Section and Receive PCS Section Also, updated Sync Byte State Machine Diagram 1. - Updated typos found in the Mode of Operations Section. - Updated the Trunking Mode Section to include the statement that fewer than 4 channels can be used. - Updated the CODE_ERR_EXCEED bit description to indicate that the coding error counters in all channels will be cleared whenever the CODE_ERR_STB is set. - Updated PKT_CNT bit description to indicate that a value of 0x7FFF will not set the CODE_ERR_EXCEED to a logic 1. - Re-wrote the Packet Generator and Packet Comparator Section. - Added text to FILTER_COEFFICIENTS to state that a value of 0x0 is not allowed. - Tagged FIFO_CNT_THRESHOLD bits in register 0x11 so that they are marked as reserved in Data Sheet. - Updated FIFO_CNT_THRESHOLD bit description in register 0x11. - Replaced JTAG Timing picture with the one in the r12 engineering document template. - Split out VCO_RESET tables in PMC Test Register 2 (0x1F) bit

		<p>description to show differences between rev A and rev B devices.</p> <ul style="list-style-type: none"> - Split out PLLBW tables in PMC Test Register 2 (0x1F) bit description to show differences between rev A and rev B devices. - Updated signal labels on Parallel Receive Timing Diagram for LRRC, Trunking, and RRRC Mode diagram (PREP # 10873). - Updated tSKEW values in Receive Timing Table and added note. - Changed 2 references of “ordered-set “ to “code-group” in the 2nd paragraph of the Byte Synchronization State Machine section. - Added text to the DIGITAL_LPBK_EN section which states that for digital loopback to work properly, only primary channels should be selected. - Added note to power requirements table that indicates the switching density at with the current measurements were made. - Corrected I_{DDA} specifications. - Added text to the SYNC_ERR_CODE_EN description to address. - modified “Storage Temperature” to –40 to +125 - inserted 1.8/2.5 in the typical column for VDDQ in D.C. Characteristics Section - Clarified packet gen/comp section. - Adjustment to V_{IL} and V_{IH} based on characterization results. - Adjusted high speed VOD output levels output differential levels based on characterization results. - Inserted 1.8/2.5 in the typical column for V_{DDQ} in D.C. Characterizations Section. - t_{TH} changed TDX minimum hold time data from 0.0 ns to 0.5 ns. - Renamed t_{RXLOCK} to B_sync in Receive Timing Table. - Added note on B_sync value at the end of the Receive Timing Table - Added Bit Synchronization Timing description in the Clock and Data Recovery Section. - Added Typ column to Reference Clock Timing Table and moved 1000ps Tr/TF Refclk Specification from Max to Typ. - Removed hidden marketing text for V_{IH} and V_{IL}.
4	June 2003	<ul style="list-style-type: none"> - Changed references relating to local clock rate and receive data rate difference from +/-400ppm to +/-200ppm - Removed the statement “This condition will typically be reached when local ambient reaches 85 °C.” from the 125C box in the Thermal Information section. - In the Transmit Timing section, the minimum TXD hold time from TXCK (t_{TH}) specification was changed from 0.5 ns to 0.0 ns. - Changed the Frequency lock after reset specification in the Reference Clock section from 2.5ms to 5.0ms. - Changed note # 4 in of the `MDC/MDIO Interface section so that the Read OP code is 0b10 and the write OP code is to read (PREP # 11724) - Changed the EXTENDED_STATUS register bit decription (bit 8 in Register 0x01). It refers to GMII regsiter 0x15. Changed it to the hex value of 0x.0F. - Added US patent issue 6,552,619 to Patents section. - Changed all references of “bps” to “bit/s”.

		<ul style="list-style-type: none"> - Changed all references of 1.0 Gbit/s to 933 Mbit/s. - Added note 4 to Fibre Channel Jitter Specification table indicating that the jitter values are also applicable to 933 Mbit/s operation. - Added 93.3 MHz timing to Parallel Rx and Tx Timing Specification Tables. - Added RBC Duty Cycle specification to Receive Timing Table. - Reworded last Voh/Voh paragraph in Parallel Interface Section. - Replaced Table 26 Power Requirements with an updated table and associated notes. - Updated Section 19 Thermal Information
5	May 2004	<ul style="list-style-type: none"> - Returned Thermal information. Ensured that all figures were exposed. - Updated Figure 43 to show 33uF cap on VDDA power rail. - Added Note 1 to bottom of table 40 - Added Note 2 to bottom of table 40 - Updated document to reflect addition of new part number – PM8354A.
6	November 2005	Updated ordering information including RoHS-compliant device details.

Table of Contents

Legal Information.....	2
Copyright.....	2
Disclaimer	2
Trademarks	2
Patents 2	
Contacting PMC-Sierra.....	3
Revision History.....	4
Table of Contents.....	9
List of Registers.....	11
List of Figures	12
List of Tables.....	14
1 Definitions	16
2 Features.....	17
3 Applications.....	19
4 References.....	20
5 Application Examples.....	21
5.1 Gigabit Ethernet Switch/Router Application	21
5.2 IEEE 802.3-2000 Gigabit Ethernet Transceiver.....	22
6 Block Diagram.....	23
7 Description	24
7.1 Overview	24
8 Pin Diagram	26
9 Pin Description.....	27
10 Functional Description	41
10.1 Modes of Operation.....	41
10.2 Channel Redundancy.....	49
10.3 Serial Channel Overview.....	50
10.4 JTAG Test Access Port.....	72
10.5 Microprocessor Interface.....	77
11 Normal Mode Register Description.....	82
11.1 IEEE Defined Registers	82
11.2 PMC-Sierra Specific Registers.....	102
12 Test Features Description	126

12.1	Packet Generator and Packet Comparator	126
12.2	JTAG Test Access Port.....	128
13	Operation	130
13.1	Power-up	130
13.2	Parallel Interface	130
13.3	High-Speed Serial Interface	131
13.4	Clock Requirements	132
13.5	Hardware/Software Configuration Options	132
13.6	Analog Considerations	132
13.7	JTAG Considerations	132
14	Functional Timing	133
14.1	MDC/MDIO Interface.....	133
15	Absolute Maximum Ratings	135
16	Power Information.....	136
16.1	Power Requirements.....	136
16.2	Power Sequencing	138
16.3	Power Supply Filtering	138
16.4	Power Supply Decoupling	138
17	D.C. Characteristics	140
18	Interface Timing Characteristics.....	142
18.1	Reference Clock.....	142
18.2	Asynchronous Reset	142
18.3	MII Management Interface (MDC/MDIO)	143
18.4	JTAG.....	144
18.5	Transmit Timing	146
18.6	Receive Timing.....	146
18.7	Receive Latency.....	148
18.8	Transmit Latency	149
18.9	High-speed Serial Timing Characteristics	150
18.10	Terminal Input Capacitance.....	152
19	Ordering & Thermal Information	153
19.1	Ordering Information	153
19.2	Thermal Information	154
20	Mechanical Information.....	156

List of Registers

Register 0x00: GMII Control	82
Register 0x01: GMII Status	85
Register 0x02: GMII PHY Identifier 1	88
Register 0x03: GMII PHY Identifier 2	90
Register 0x04: GMII Auto-Negotiation Advertisement	91
Register 0x05: GMII Auto-Negotiation Link Partner Ability Base Page.....	93
Register 0x06: GMII Auto-Negotiation Expansion.....	95
Register 0x07: GMII Auto-Negotiation Next Page Transmit.....	96
Register 0x08: GMII Auto-Negotiation Link Partner Next Page Ability	98
Register 0x09 through 0x0E: Reserved	100
Register 0x0F: GMII Extended Status.....	101
Register 0x10: PMC Control 1.....	102
Register 0x11: PMC Control 2.....	104
Register 0x12: IDLE 1	107
Register 0x13: IDLE 2	108
Register 0x14: IDLE 1A.....	109
Register 0x15: IDLE 2A.....	110
Register 0x16: Loopback Control.....	111
Register 0x17: Trunking Control.....	113
Register 0x18: PMC Control 3.....	115
Register 0x19: Auto-Negotiation Status 1	118
Register 0x1A: Auto-Negotiation Status 2.....	119
Register 0x1B: Packet Generator/Checker Control/Status	120
Register 0x1C: Packet Generator Count Control	122
Register 0x1D: Redundancy Control.....	124

List of Figures

Figure 1	QuadPHY 1G in Switch/Router Applications	21
Figure 2	IEEE 802.3-2000 Gigabit Ethernet Supported Functions	22
Figure 3	QuadPHY 1G Block Diagram.....	23
Figure 4	QuadPHY 1G Detailed Channel Block Diagram	25
Figure 5	QuadPHY 1G Pin Diagram (Bottom View).....	26
Figure 6	LRRC Mode Receive Data Path	42
Figure 7	RRRC Mode Receive Data Path.....	46
Figure 8	Receive Data Path for HRRC Mode	48
Figure 9	Parallel Loopback Data Path.....	49
Figure 10	Transmit Channel Functional Blocks	52
Figure 11	Transmit Timing	53
Figure 12	Receive Channel Functional Blocks	55
Figure 13	Byte Synchronization State Machine	59
Figure 14	Insertion/Deletion of Idle Sequences by the Receive FIFO	61
Figure 15	Trunking Mode Channel Alignment using Alignment Characters	63
Figure 16	Trunking Mode Channel Alignment using the Transition from Idle to Data.....	64
Figure 17	Insertion of a Column of Idle Sequences when Trunking	65
Figure 18	Deletion of a Column of Idle Sequences when Trunking.....	66
Figure 19	Deskew State Machine	68
Figure 20	Receive Timing for RRRC Mode.....	70
Figure 21	Receive Timing for LRRC and Trunking Mode	70
Figure 22	Receive Timing for HRRC Mode.....	71
Figure 23	Boundary Scan Architecture	73
Figure 24	TAP Controller Finite State Machine.....	74
Figure 25	Register Access	78
Figure 26	Behavior of MDIO During TA Field of a Read Transaction.....	80
Figure 27	Serial Loopback Data Path with Packet Generator/Comparator Enabled	128
Figure 28	Parallel Receive and Transmit Interface	130
Figure 29	High-Speed Serial Interface	131
Figure 30	MDC/MDIO Write Cycle	133
Figure 31	MDC/MDIO Read Cycle	133
Figure 32	Behavior of MDIO During TA Field of a Read Transaction.....	134

Figure 33	Recommended Power Supply Decoupling	139
Figure 34	QuadPHY 1G Reset Timing	143
Figure 35	MDIO Timing Diagram	143
Figure 36	MDIO Sourced by PHY	144
Figure 37	JTAG Port Interface Timing.....	145
Figure 38	Parallel Transmit Timing (All Modes).....	146
Figure 39	Parallel Receive Timing Diagram for LRRC, Trunking, and RRRC Mode	148
Figure 40	Parallel Receive Timing Diagram for HRRC Mode.....	148
Figure 41	Receive Latency.....	149
Figure 42	Transmit Latency.....	149
Figure 43	933 Mbit/s to 1.25 Gbit/s Serial I/O Block Diagram.....	150
Figure 44	Differential Peak-Peak Receiver Eye Diagram	150
Figure 45	Mechanical Drawing 289 Pin CABGA.....	156

List of Tables

Table 1	Definitions.....	16
Table 2	Receive Path Pins.....	27
Table 3	Transmit Path Pins.....	30
Table 4	MDC/MDIO Pins.....	32
Table 5	Configuration/Status Pins.....	33
Table 6	JTAG Pins.....	35
Table 7	Miscellaneous Pins.....	36
Table 8	Digital Power and Digital Ground Pins.....	36
Table 9	Analog Power and Ground Pins.....	40
Table 10	LRRRC Mode Options.....	43
Table 11	Trunking Mode Options.....	45
Table 12	RRRC Mode Options.....	46
Table 13	HRRC Mode Options.....	48
Table 14	Valid K Bit Values.....	51
Table 15	Example REFCLK and PLL Clock Combinations.....	52
Table 16	Parallel Transmit Interface Pin Mapping.....	54
Table 17	Maximum Packet Size Supported.....	67
Table 18	Parallel Receive Interface Pin Mapping.....	72
Table 19	Management Interface Frame Format.....	79
Table 20	Register Memory Map.....	80
Table 21	Instruction Register.....	129
Table 22	Identification Register.....	129
Table 23	Hardware/Software Configuration Options.....	132
Table 24	Maximum Ratings.....	135
Table 25	Power Requirements.....	136
Table 26	D.C. Characteristics.....	140
Table 27	Reference Clock Timing.....	142
Table 28	QuadPHY 1G Reset Timing.....	142
Table 29	MDIO Timing.....	143
Table 30	JTAG Port Interface.....	144
Table 31	Transmit Timing.....	146
Table 32	Receive Timing.....	146
Table 33	Receive Latency Timing.....	148

Table 34	Transmit Latency Timing	149
Table 35	High-speed I/O Characteristics ($V_{DD} = 1.8\text{ V}$)	151
Table 36	Gigabit Ethernet Jitter Specifications ²	151
Table 37	Fibre Channel Jitter Specifications ³	152
Table 38	Ordering Information	153
Table 39	Outside Plant Thermal Information	154
Table 40	Thermal Resistance vs. Air Flow ³	154
Table 41	Device Compact Model ⁴	154
Table 42	Outside Plant Thermal Information	155
Table 43	Device Compact Model	155
Table 44	Heat Sink Requirements	155

1 Definitions

All references to PM8354 in this document denote both PM8354 and PM8354A.

The following table defines terms and abbreviations used in this document.

Table 1 Definitions

Term	Definition
ANSI	American National Standards Institute
ASIC	Application Specific Integrated Circuit
BIST	Built-in Self Test
CABGA	Chip Array Ball Grid Array
CMOS	Complementary Metal-oxide Silicon
COL	Collision Detect.
CRS	Carrier Sense
DDR	Dual Data Rate
FIFO	First In, First Out
GMII	Gigabit Medium-Independent Interface
IEEE	Institute of Electrical and Electronics Engineers
IPG	Interpacket Gap
JTAG	Joint Test Action Group
MDC/MDIO	Management Data Clock/Management Data Input/Output
PCS	Physical Coding Sublayer

2 Features

General

- Four 933 Mbit/s to 1.25 Gbit/s IEEE 802.3-2000 Gigabit Ethernet and Fibre Channel Physical Interfaces (FC-PI) System Compliant Transceivers
- Four secondary channels to support channel redundancy
- Configurable as four independent channels or as a single logical trunked channel with deskew providing up to 4 Gbit/s duplex data throughput
- Integrated clock synthesis, clock recovery, serializer/deserializer, built-in self-test, 8B/10B codec and IEEE 802.3-2000 Gigabit Ethernet Physical Coding Sublayer (PCS) logic
- Rate matching via IDLE character insertion and deletion capable of compensating up to ± 200 ppm of difference between the local REFCLK and the incoming data
- Pin programmable or software configurable operation using 2 pin IEEE 802.3 MDC/MDIO serial management interface
- Ultra-low power operation using 0.18 μ technology

Serial Interface

- High-speed outputs feature programmable output current to optimize drive distance and power - directly drives 50 Ω (100 Ω differential) systems
- Direct AC coupled interface to copper serial backplanes, optics and coaxial cable
- Low threshold receive differential input threshold

Parallel Interface

- SDR parallel interface with synchronous receive clock (clock forwarding)
- Half Rate Mode that supports Dual Data Rate
- Supports GMII and TBI (Ten-bit Interface) standards.
- Receive channel output clocks eliminate the need for PLLs in interface ASICs
- 1.8 V and 2.5 V interoperable; 3.3 V tolerant

Test Features

- IEEE 1149.1 JTAG Boundary Scan support
- Built-in self-test (BIST) via internal packet generator/checker
- Per-channel control of serial and parallel loopback
- 8B/10B error counters

Physical

- Thermally enhanced 289-pin, 19mm x 19mm CABGA Package

3 Applications

- High-speed serial backplanes
- IEEE 802.3-2000 Gigabit Ethernet dense line cards
- ANSI X3T11 Fibre Channel dense line cards
- Link Aggregation
- Intra-system and inter-system interconnect
- Chassis Extender

4 References

1. IEEE 802.3-2000 Gigabit Ethernet, 2000 Edition
2. Methodologies for Jitter and Signal Quality Specification (MJSQ) Rev. 4.0
3. Fibre Channel Physical Interfaces (FC-P1) Rev. 13
4. IEEE 1149.1-2001 Standard Test Access Port and Boundary Scan Architecture, 23 July 2001.
5. PMC-2012433, QuadPHY 1G Telecom Standard Product Data Sheet
6. PMC-2030175, Octal/QuadPHY 1G Board Level Design and Debug Tips
7. PMC-2012358, OctalPHY 1G/QuadPHY 1G Evaluation Board Design
8. PMC-2022181, OctalPHY/QuadPHY 1G Evaluation Kit User's Guide

5 Application Examples

The QuadPHY 1G has numerous applications in networking, storage and computing systems requiring high-speed serial I/O technology. Typical applications include backplane interconnect, Gigabit Ethernet line cards and Fiber Channel line cards.

5.1 Gigabit Ethernet Switch/Router Application

Figure 1 shows the QuadPHY 1G being used in a Gigabit Ethernet Switch/Router Application. This application demonstrates the many uses of the QuadPHY 1G. On the line cards, the QuadPHY 1G provides the Gigabit Ethernet transceiver function as well as the interface to the backplane. On the switch card, the QuadPHY 1G provides a dense high-speed backplane interconnect to the line cards over a copper backplane.

Figure 1 QuadPHY 1G in Switch/Router Applications

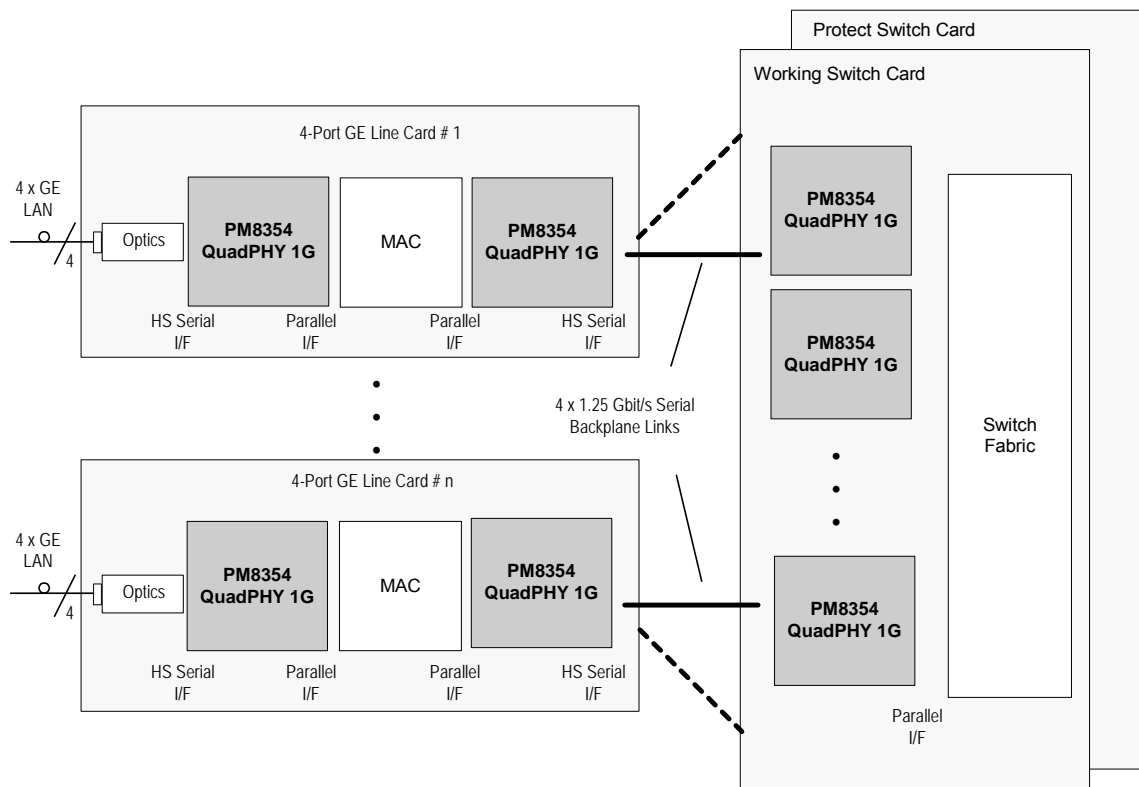

5.2 IEEE 802.3-2000 Gigabit Ethernet Transceiver

As a Gigabit Ethernet Transceiver, the QuadPHY 1G integrates the PCS layer down to the PMA layer for fiber mediums and down to the PMD layer for copper mediums. Figure 2 shows in gray shade, the supported functions of the device. The QuadPHY 1G may be configured to enable or disable certain layers.

Figure 2 IEEE 802.3-2000 Gigabit Ethernet Supported Functions

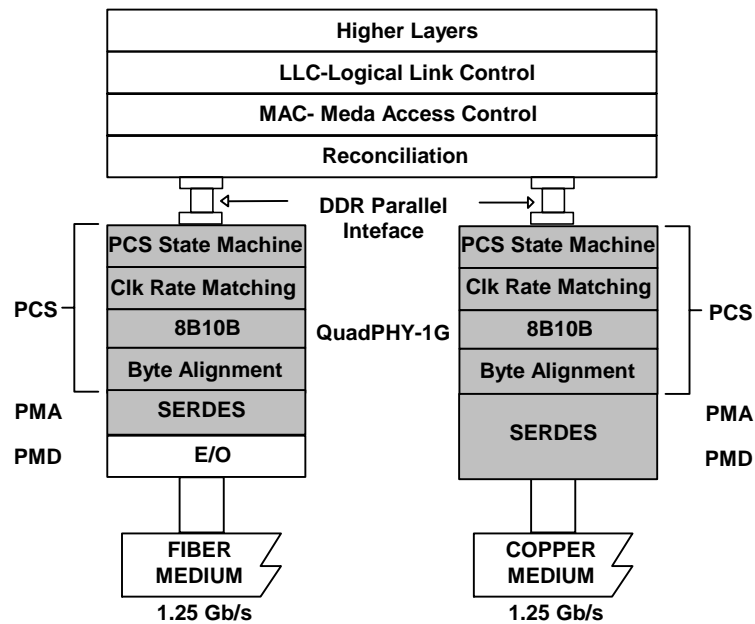

6 Block Diagram

The block diagram of the QuadPHY 1G is shown in Figure 3.

Figure 3 QuadPHY 1G Block Diagram

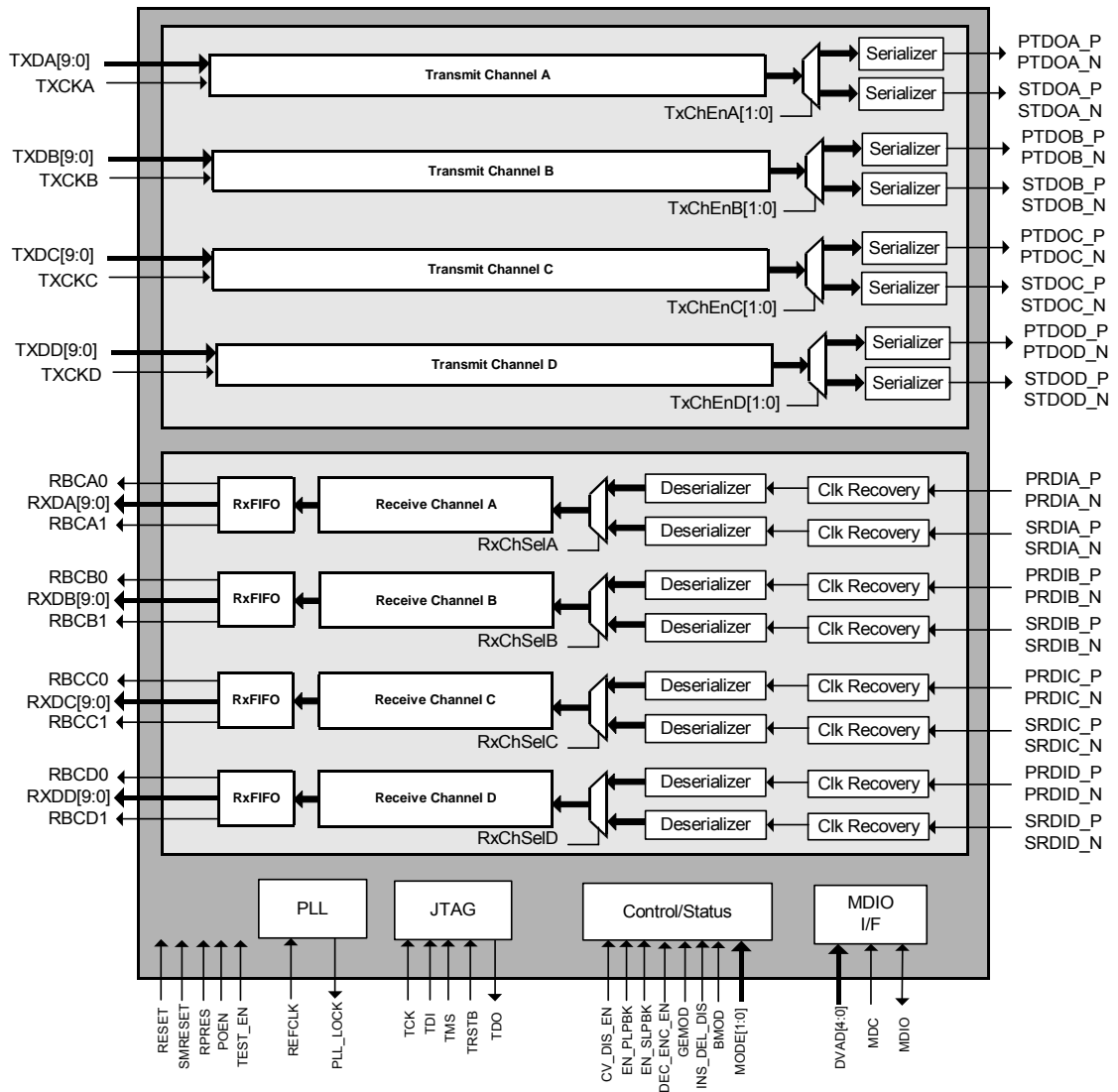

7 Description

7.1 Overview

The PM8354 QuadPHY 1G is a low power four channel transceiver suitable for applications such as high-speed serial backplanes and dense Gigabit Ethernet line cards.

In the transmit direction, the PM8354 takes 8-bit or 10-bit data, serializes the data and transmits the data differentially at 933 Mbit/s - 1.25 Gbit/s. The PM8354 integrates a SDR/DDR parallel interface, 8B/10B encoder, IEEE 802.3-2000 Gigabit Ethernet PCS logic, trunking logic, serializer, clock synthesis unit and differential transmitters.

In the receive direction, the PM8354 receives serial differential data, recovers the data and converts the data back to 8-bit or 10-bit data. The PM8354 integrates differential receivers, clock recovery unit, PCS logic, 8B/10B decoder, receive FIFOs and a SDR/DDR parallel interface.

In addition to these fundamental SERDES functions, the PM8354 provides other features such as trunking and rate compensation.

The PM8354 has the ability to trunk data across the four channels at the transmitter and deskew/realign the data at the receiver. This trunking feature enables the device to provide up to a 4 Gbit/s single logical channel. A system requires deskew due to mismatches in propagation delay between channels. The PM8354 can compensate for this lane-to-lane skewing.

A system requires rate compensation if the transmitting device and receiving device are operating from different clock sources (asynchronous system). For example, if four asynchronous 1.25 Gbit/s links from four line cards are transmitting over a backplane to one receiving device, the receiving device must provide rate compensation to achieve a common local clock. The receive logic compensates for these clock differences by inserting or deleting special 8B/10B IDLE characters.

The QuadPHY 1G provides redundant serial transmit and serial receive ports. The active port can be selected through the Management Interface for each pair of transmit and receive ports.

The PM8354 has four primary channels and 4 secondary channels (A to D). Figure 4 shows a detailed block diagram of channel A's primary and secondary channels. The block diagrams of channels B, C, and D are identical to channel A's primary and secondary channels.

Figure 4 QuadPHY 1G Detailed Channel Block Diagram

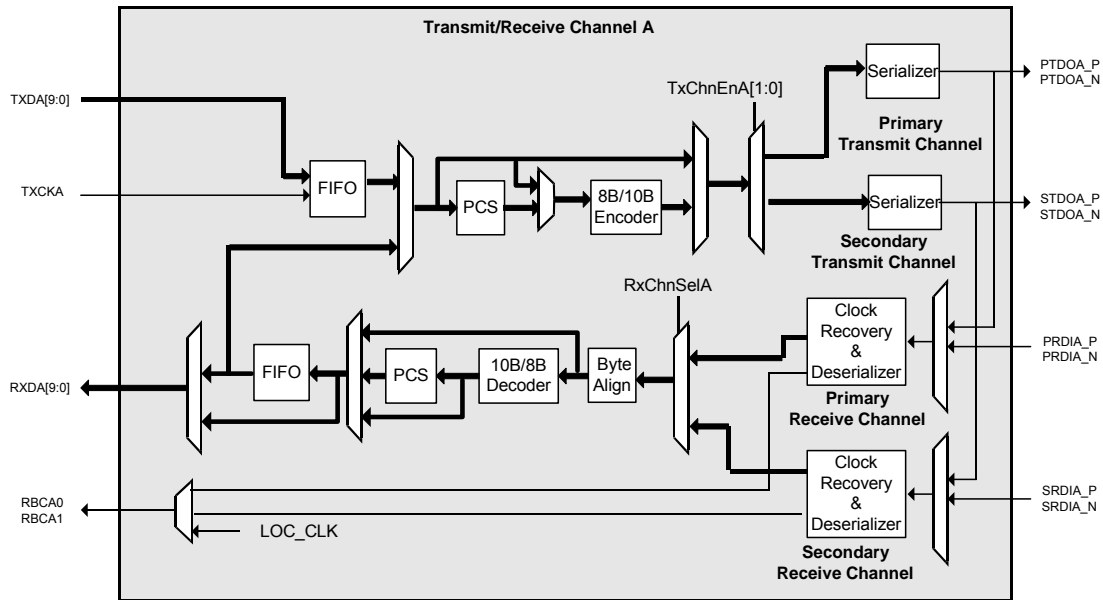

The QuadPHY 1G supports IEEE 802.3-2000 Gigabit Ethernet and Fibre Channel Physical Interfaces (FC-PI) Rev. 13. The high-speed outputs feature programmable output current that enables directly driving 50 Ω (100 Ω differential) systems. This allows direct interface to optical modules, coax, or serial backplanes.

The QuadPHY 1G supports a Single Data Rate (SDR) or a Dual Data Rate (DDR) Parallel Interface with independent receive and transmit ports. Depending on which mode of operation is being used, the QuadPHY 1G parallel interface will operate as a SDR interface or a DDR interface: Section 10.1, Modes of Operation, describes these interfaces in detail.

The selection of interface modes, as well as operating features such as the internal 8B/10B encoding/decoder, full duplex PCS, frequency compensation, Trunking, and parallel loopback, can be done via the 2 pin serial MDC/MDIO management interface or through external pins for systems that do not support MDC/MDIO.

A 2-pin serial management interface using IEEE 802.3 MDC/MDIO protocol for configuration and diagnostic access is also provided. The QuadPHY 1G supports various loopback modes for testing and debug including individual serial channel loopback. Support for built-in self test (BIST) via an internal packet generator/checker is also provided on a per transceiver basis.

The part is produced in 0.18 μm , 1.8 V CMOS technology with compatible 1.8/2.5 V I/Os. IEEE 1149.1 JTAG is fully supported and the 289-pin CABGA package has a small 19x19 mm footprint.

8 Pin Diagram

The QuadPHY 1G is packaged in a 289-ball Chip Array Ball Grid Array (CABGA) package having a body size of 19 mm by 19 mm. Figure 5 shows the bottom view of the pin diagram of the QuadPHY 1G.

Figure 5 QuadPHY 1G Pin Diagram (Bottom View)

	17	16	15	14	13	12	11	10	9	8	7	6	5	4	3	2	1	
A	GND	PTD00_P	PTD00_N	GND	TXD0[8]	TXD0[6]	TXD0[4]	TXD0[2]	TXD0[0]	TXD0[8]	TXD0[6]	TXD0[4]	TXD0[2]	TXD0[0]	TXD0[8]	TXD0[4]	TXD0[0]	A
B	GND	STD00_P	STD00_N	GND	TXD0[8]	TXD0[7]	TXD0[5]	TXD0[3]	TXD0[1]	TXD0[9]	TXD0[7]	TXD0[5]	TXD0[3]	TXD0[1]	TXD0[9]	TXD0[5]	TXD0[1]	B
C	GND	PTD0C_P	PTD0C_N	GND	RPRES	REFCLK	TMS	TCK	TDI	GEMOD	TDO	TXCKD	TXCKC	TXCKB	TXD0[8]	TXD0[1]	TXD0[0]	C
D	GND	STD0C_P	STD0C_N	GND	POEN	DVAD[4]	DVAD[3]	NC	NC	TRSTB	EN_SLPBK	NC	NC	NC	TXD0[7]	TXDA[1]	TXDA[0]	D
E	GND	PTD0B_P	PTD0B_N	GND	VDD	VDD	VDD	VDD	VDDQ	VDDQ	VDDQ	VDDQ	VDDQ	GND	TXCKA	TXDA[3]	TXDA[2]	E
F	GND	STD0B_P	STD0B_N	GND	VDD	T_GND	T_GND	T_GND	T_GND	T_GND	T_GND	T_GND	VDDQ	GND	NC	TXDA[5]	TXDA[4]	F
G	GND	PTD0A_P	PTD0A_N	GND	VDD	T_GND	T_GND	T_GND	T_GND	T_GND	T_GND	T_GND	VDDQ	GND	RESET	TXDA[7]	TXDA[6]	G
H	GND	STD0A_P	STD0A_N	GND	VDD	T_GND	T_GND	T_GND	T_GND	T_GND	T_GND	T_GND	VDDQ	GND	MDC	TXDA[9]	TXDA[8]	H
J	GND	GND	VDDA	VDDA	VDD	T_GND	T_GND	T_GND	T_GND	T_GND	T_GND	T_GND	VDDQ	GND	CV_DIS_EN	DEC_ENC_EN	MDIO	J
K	GND	PRD0_P	PRD0_N	GND	VDD	T_GND	T_GND	T_GND	T_GND	T_GND	T_GND	T_GND	VDDQ	GND	TEST_EN	RXDA[1]	RXDA[0]	K
L	GND	SRD0_P	SRD0_N	GND	VDD	T_GND	T_GND	T_GND	T_GND	T_GND	T_GND	T_GND	VDDQ	GND	SMRESET	RXDA[3]	RXDA[2]	L
M	GND	PRD0C_P	PRD0C_N	GND	VDD	T_GND	T_GND	T_GND	T_GND	T_GND	T_GND	T_GND	VDDQ	GND	INS_DEL_DIS	RXDA[5]	RXDA[4]	M
N	GND	SRD0C_P	SRD0C_N	GND	VDD	VDD	VDD	VDD	VDDQ	VDDQ	VDDQ	VDDQ	VDDQ	GND	ENPLBPBK	RXDA[7]	RXDA[6]	N
P	GND	PRD0B_P	PRD0B_N	GND	DVAD[2]	MODE[1]	MODE[0]	NC	BMOD	NC	NC	NC	NC	RBCA0	RXD0[7]	RXD0[9]	RXD0[8]	P
R	GND	SRD0B_P	SRD0B_N	GND	DVAD[1]	DVAD[0]	PLL_LOCK	RBCD1	RBCD0	RBC01	RBC00	RXC01	RXC00	RBCA1	RXD0[6]	RXD0[1]	RXD0[0]	R
T	GND	PRD0A_P	PRD0A_N	GND	RXD0[8]	RXD0[7]	RXD0[5]	RXD0[3]	RXD0[1]	RXD0[9]	RXD0[7]	RXD0[5]	RXD0[3]	RXD0[1]	RXD0[9]	RXD0[5]	RXD0[1]	T
U	GND	SRD0A_P	SRD0A_N	GND	RXD0[8]	RXD0[6]	RXD0[4]	RXD0[2]	RXD0[0]	RXD0[8]	RXD0[6]	RXD0[4]	RXD0[2]	RXD0[0]	RXD0[8]	RXD0[4]	RXD0[0]	U
	17	16	15	14	13	12	11	10	9	8	7	6	5	4	3	2	1	

9 Pin Description

The following tables describe all pins of the QuadPHY 1G.

Table 2 Receive Path Pins

Pin Name	Type	Pin No.	Function
SRDIA_P SRDIA_N PRDIA_P PRDIA_N SRDIB_P SRDIB_N PRDIB_P PRDIB_N SRDIC_P SRDIC_N PRDIC_P PRDIC_N SRDID_P SRDID_N PRDID_P PRDID_N	Input High-speed Differential	U16 U15 T16 T15 R16 R15 P16 P15 N16 N15 M16 M15 L16 L15 K16 K15	Differential, high-speed serial Receive Data Input pins . This data must be 8B/10B line coded and operate in the range from 933 Mbit/s and 1.25 Gbit/s. The differential inputs are internally terminated with 100 Ω differential terminations. These ports are ignored when Serial Loopback is enabled using either the EN_SLPBK input or the INT_EN_SERIAL_LPBK [D:A] bits in Loopback Register (Register 0x16). These inputs are enabled by default. If a channel is enabled, active data must be provided to it. Do not use pull-up/pull-down resistors on the high-speed differential inputs. These inputs may be left unconnected when this channel is not used .
RBCA0	Output CMOS	P4	In HRRC Mode, the Receive Backplane Channel A0 clock is 180 degrees out of phase with the RBCA1 clock. In HRRC Mode, the rising edge of RBCA0 can be used to sample odd data on RXDA[9:0]. In RRRC mode, the RBCA0 pin is not used and should be left unconnected. While in LRRC, Trunking, or Parallel Loopback Mode, the RXCLK4 bit 4 in Register 0x18 PMC Control 3 determines whether the RBCA0 pin is active or inactive.
RBCA1	Output CMOS	R4	In HRRC or RRRC Mode, the Receive Backplane Channel A1 clock is the receive clock for Channel A. In RRRC mode the rising edge of RBCA1 can be used to sample RXDA[9:0]. In HRRC Mode, the rising edge of RBCA1 can be used to sample even data on RXDA[9:0]. While in LRRC, Trunking, or Parallel Loopback Mode, the RXCLK4 bit 4 in Register 0x18 PMC Control 3 determines whether the RBCA1 pin is active or inactive.

Pin Name	Type	Pin No.	Function
RXDA[9] RXDA[8] RXDA[7] RXDA[6] RXDA[5] RXDA[4] RXDA[3] RXDA[2] RXDA[1] RXDA[0]	Output CMOS	P2 P1 N2 N1 M2 M1 L2 L1 K2 K1	<p>Parallel Receive Data Backplane from primary or secondary channel A (PRDIA_P, PRDIA_N or SRDIA_P, SRDIA_N). When PCS_ENABLE is 1, this data may optionally be 8B/10B decoded. If decoded, Bits 9:0 of RXDA are defined as (Error Bit + K Bit + Data[7:0]). Data that appears here is provided in a SDR fashion when operating in Trunking, LRRC or RRRC modes and in a DDR fashion when operating in HRRC Mode.</p> <p>RXDA0 represents the first bit of the word received on the differential pairs PRDIA_P, PRDIA_N or SRDIA_P, SRDIA_N.</p> <p>When in Trunking or LRRC Mode, RXDA[9:0] is updated using either the rising edges of RBCA1 or RBCD1 depending on the state of control bit RXCLK4. When in RRRC Mode, RXDA[9:0] is updated using the rising edges of RBCA1. For HRRC Mode, RXDA[9:0] is updated using both the rising edges of RBCA1 and RBCA0.</p>
RBCB0	Output CMOS	R5	<p>In HRRC Mode, the Receive Backplane Channel B0 clock is 180 degrees out of phase with the RBCB1 clock. In HRRC Mode, the rising edge of RBCB0 can be used to sample odd data on RXDB[9:0]. In RRRC mode, the RBCB0 pin is not used and should be left unconnected. While in LRRC, Trunking, or Parallel Loopback Mode, the RXCLK4 bit 4 in Register 0x18 PMC Control 3 determines whether the RBCB0 pin is active or inactive.</p>
RBCB1	Output CMOS	R6	<p>In HRRC or RRRC Mode, the Receive Backplane Channel B1 clock is the receive clock for Channel B. In RRRC mode the rising edge of RBCB1 can be used to sample RXDB[9:0]. In HRRC Mode, the rising edge of RBCB1 can be used to sample even data on RXDB[9:0]. While in LRRC, Trunking, or Parallel Loopback Mode, the RXCLK4 bit 4 in Register 0x18 PMC Control 3 determines whether the RBCB1 pin is active or inactive.</p>
RXDB[9] RXDB[8] RXDB[7] RXDB[6] RXDB[5] RXDB[4] RXDB[3] RXDB[2] RXDB[1] RXDB[0]	Output CMOS	T3 U3 P3 R3 T2 U2 U1 T1 R2 R1	<p>Parallel Receive Data Backplane from primary or secondary channel B (PRDIB_P, PRDIB_N or SRDIB_P, SRDIB_N). When PCS_ENABLE is 1, This data may optionally be 8B/10B decoded. If decoded, Bits 9:0 of RXDB are defined as (Error Bit + K Bit + Data[7:0]). Data that appears here is provided in a SDR fashion when operating in Trunking, LRRC or RRRC modes and in a DDR fashion when operating in HRRC Mode.</p> <p>RXDB0 represents the first bit of the word received on the differential pairs PRDIB_P, PRDIB_N or SRDIB_P, SRDIB_N.</p> <p>When in Trunking or LRRC Mode, RXDB[9:0] is updated using either the rising edges of RBCB1 or RBCD1 depending on the state of control bit RXCLK4. When in RRRC Mode, RXDB[9:0] is updated using the rising edges of RBCB1. For HRRC Mode, RXDB[9:0] is updated using both the rising edges of RBCB1 and RBCB0.</p>

Pin Name	Type	Pin No.	Function
RBCC0	Output CMOS	R7	In HRRC Mode, the Receive Backplane Channel C0 clock is 180 degrees out of phase with the RBCA1 clock. In HRRC Mode, the rising edge of RBCC0 can be used to sample odd data on RXDC[9:0]. In RRRC mode, the RBCC0 pin is not used and should be left unconnected. While in LRRC, Trunking, or Parallel Loopback Mode, the RXCLK4 bit 4 in Register 0x18 PMC Control 3 determines whether the RBCC0 pin is active or inactive.
RBCC1	Output CMOS	R8	In HRRC or RRRC Mode, the Receive Backplane Channel C1 clock is the receive clock for Channel C. In RRRC mode the rising edge of RBCC1 can be used to sample RXDC[9:0]. In HRRC Mode, the rising edge of RBCC1 can be used to sample even data on RXDC[9:0]. While in LRRC, Trunking, or Parallel Loopback Mode, the RXCLK4 bit 4 in Register 0x18 PMC Control 3 determines whether the RBCC1 pin is active or inactive.
RXDC[9] RXDC[8] RXDC[7] RXDC[6] RXDC[5] RXDC[4] RXDC[3] RXDC[2] RXDC[1] RXDC[0]	Output CMOS	T8 U8 T7 U7 T6 U6 T5 U5 T4 U4	Parallel Receive Data Backplane from primary or secondary channel C (PRDIC_P, PRDIC_N or SRDIC_P, SRDIC_N) . When PCS_ENABLE is 1, this data may optionally be 8B/10B decoded. If decoded, Bits 9:0 of RXDC are defined as (Error Bit + K Bit + Data[7:0]). Data that appears here is provided in a SDR fashion when operating in Trunking, LRRC or RRRC modes and in a DDR fashion when operating in HRRC Mode. RXDC0 represents the first bit of the word received on the differential pairs PRDIC_P, PRDIC_N or SRDIC_P, SRDIC_N. When in Trunking or LRRC Mode, RXDC[9:0] is updated using either the rising edges of RBCC1 or RBCD1 depending on the state of control bit RXCLK4. When in RRRC Mode, RXDC[9:0] is updated using the rising edges of RBCC1. For HRRC Mode, RXDC[9:0] is updated using both the rising edges of RBCC1 and RBCC0.
RBCD0	Output CMOS	R9	In HRRC Mode, the Receive Backplane Channel D0 clock is 180 degrees out of phase with the RBCD1 clock. In HRRC Mode, the rising edge of RBCD0 can be used to sample odd data on RXDD[9:0]. In RRRC mode, the RBCD0 pin is not used and should be left unconnected. While in LRRC, Trunking, or Parallel Loopback Mode, the RBCD0 pin is the complementary clock that RXDA[9:0], RXDB[9:0], RXDC[9:0], and RXDD[9:0] is referenced to. The RXCLK4 bit 4 in Register 0x18 PMC Control 3 determines whether the RBCD0 signal is output on the RBCA0, RBCB0 and RBCC0 clock outputs.
RBCD1	Output CMOS	R10	In HRRC or RRRC Mode, the Receive Backplane Channel D1 clock is the receive clock for Channel D. In RRRC mode the rising edge of RBCD1 can be used to sample RXDD[9:0]. In HRRC Mode, the rising edge of RBCD1 can be used to sample even data on RXDD[9:0]. While in LRRC, Trunking, or Parallel Loopback Mode, the RBCD1 pin is the clock that RXDA[9:0], RXDB[9:0], RXDC[9:0] and RXDD[9:0] is referenced to. The RXCLK4 bit 4 in Register 0x18 PMC Control 3 determines whether the RBCD1 signal is output on the RBCA1, RBCB1 and RBCC1 clock outputs.

Pin Name	Type	Pin No.	Function
RDDD[9] RXDD[8] RXDD[7] RXDD[6] RXDD[5] RXDD[4] RXDD[3] RXDD[2] RXDD[1] RXDD[0]	Output CMOS	T13 U13 T12 U12 T11 U11 T10 U10 T9 U9	<p>Parallel Receive Data Backplane from primary or secondary channel D (PRDID_P, PRDID_N or SRDID_P, SRDID_N). When PCS_ENABLE is 1, this data may optionally be 8B/10B decoded. If decoded, Bits 9:0 of RXDD are defined as (Error Bit + K Bit + Data[7:0]). Data that appears here is provided in a SDR fashion when operating in Trunking, LRRC or RRRC modes and in a DDR fashion when operating in HRRC Mode.</p> <p>RXDD0 represents the first bit of the word received on the differential pairs PRDID_P, PRDID_N or SRDID_P, SRDID_N.</p> <p>When in Trunking, LRRC, or RRRC Mode, RXDD[9:0] is updated using the rising edges of RBCD1. For HRRC Mode, RXDC[9:0] is updated using both the rising edges of RBCC1 and RBCC0.</p>

Table 3 Transmit Path Pins

Pin Name	Type	Pin No.	Function
STDOA_P STDOA_N PTDOA_P PTDOA_N STDOB_P STDOB_N PTDOB_P PTDOB_N STDOC_P STDOC_N PTDOC_P PTDOC_N STDOD_P STDOD_N PTDOD_P PTDOD_N	Output High-speed Differential	H16 H15 G16 G15 F16 F15 E16 E15 D16 D15 C16 C15 B16 B15 A16 A15	<p>Differential, high-speed serial Transmit Data Output pins. This data is operating from between 933 Mbit/s and 1.25 Gbit/s and is 8B/10B encoded.</p> <p>The differential outputs are internally terminated with 100-ohm differential terminations.</p> <p>These outputs are inactive are inactive when serial loopback is enables.</p> <p>These outputs are enabled by default.</p> <p>Do not use pull-up or pull-down resistors on the high-speed differential outputs.</p> <p>The outputs may be left unconnected if this channel is not used</p>
TXCKA	Input CMOS	E3	<p>Parallel Transmit Clock for Channel A. The rising edges of TXCKA is used to clock in TXDA[9:0].</p> <p>In all modes of operation, Channel A Transmit Data is loaded in on the rising edge of TXCKA.</p> <p>TXCKA can optionally be used to clock in data for all of the input parallel transmit ports (TXDA, TXDB, TXDC, TXDD). When the TXCLK4 bit in PMC Control 2 Register is set to logic 0, all of the TXDy ports are sampled by a common clock, TXCKA. This configuration is required when operating in Trunking Mode.</p> <p>If this pin is not used, it should be tied to ground.</p>

Pin Name	Type	Pin No.	Function
TXDA[9] TXDA[8] TXDA[7] TXDA[6] TXDA[5] TXDA[4] TXDA[3] TXDA[2] TXDA[1] TXDA[0]	Input CMOS	H2 H1 G2 G1 F2 F1 E2 E1 D2 D1	<p>Parallel Transmit Data Backplane to primary or secondary channel A (PTDOA_P, PTDOA_N or STDOA_P, STDOA_N). This data can optionally be 8B/10B encoded. If encoded, Bits 9:0 of TXDA are defined as (Reserved Bit + K Bit + Data[7:0]). Data that appears here is provided in a SDR fashion regardless of operating mode.</p> <p>In all modes of operation, TXDA0 represents the first bit of the word that is transmitted on the differential pairs PTDOA_P, PTDOA_N and STDOA_P, STDOA_N.</p> <p>In all modes of operation, TXCKA is used to load in data using its rising edges.</p> <p>If these pins are not used, they should be tied to ground.</p>
TXCKB	Input CMOS	C4	<p>Parallel Transmit Clock for Channel B. The rising edges of TXCKB is used to clock in TXDB[9:0].</p> <p>In all modes of operation, Channel B Transmit Data is loaded in on the rising edge of TXCKB.</p> <p>TXCKA can optionally be used to clock in data for all of the input parallel transmit ports (TXDA, TXDB, TXDC, TXDD). When the TXCLK4 bit in PMC Control 2 Register is set to logic 0, all of the TXDy ports are sampled by a common clock, TXCKA. This configuration is required when operating in Trunking Mode.</p> <p>If this pin is not used, it should be tied to ground.</p>
TXDB[9] TXDB[8] TXDB[7] TXDB[6] TXDB[5] TXDB[4] TXDB[3] TXDB[2] TXDB[1] TXDB[0]	Input CMOS	B3 A3 D3 C3 B2 A2 A1 B1 C2 C1	<p>Parallel Transmit Data Backplane to primary or secondary channel B (PTDOB_P, PTDOB_N or STDOB_P, STDOB_N). This data can optionally be 8B/10B encoded. If encoded, Bits 9:0 of TXDB are defined as (Reserved Bit + K Bit + Data[7:0]). Data that appears here is provided in a SDR fashion regardless of operating mode.</p> <p>In all modes of operation, TXDB0 represents the first bit of the word that is transmitted on the differential pairs PTDOB_P, PTDOB_N and STDOB_P, STDOB_N.</p> <p>In all modes of operation, either TXCKB or TXCKA is used to load in data using its rising edges, depending on the state of control bit TXCLK4.</p> <p>If these pins are not used, they should be tied to ground.</p>
TXCKC	Input CMOS	C5	<p>Parallel Transmit Clock for Channel C. The rising edges of TXCKC is used to clock in TXDC[9:0].</p> <p>In all modes of operation, Channel C Transmit Data is loaded in on the rising edge of TXCKC.</p> <p>TXCKA can optionally be used to clock in data for all of the input parallel transmit ports (TXDA, TXDB, TXDC, TXDD). When the TXCLK4 bit in PMC Control 2 Register is set to logic 0, all of the TXDy ports are sampled by a common clock, TXCKA. This configuration is required when operating in Trunking Mode.</p> <p>If this pin is not used, it should be tied to ground.</p>

Pin Name	Type	Pin No.	Function
TXDC[9] TXDC[8] TXDC[7] TXDC[6] TXDC[5] TXDC[4] TXDC[3] TXDC[2] TXDC[1] TXDC[0]	Input CMOS	B8 A8 B7 A7 B6 A6 B5 A5 B4 A4	<p>Parallel Transmit Data Backplane to primary or secondary channel C (PTDOC_P, PTDOC_N or STDOC_P, STDOC_N). This data can optionally be 8B/10B encoded. If encoded, Bits 9:0 of TXDC are defined as (Reserved Bit + K Bit + Data[7:0]). Data that appears here is provided in a SDR fashion regardless of operating mode.</p> <p>In all modes of operation, TXDC0 represents the first bit of the word that is transmitted on the differential pairs PTDOC_P, PTDOC_N and STDOC_P, STDOC_N.</p> <p>In all modes of operation, either TXCKC or TXCKA is used to load in data using its rising edges, depending on the state of control bit TXCLK4.</p> <p>If these pins are not used, they should be tied to ground.</p>
TXCKD	Input CMOS	C6	<p>Parallel Transmit Clock for Channel D. The rising edges of TXCKD is used to clock in TXDD[9:0].</p> <p>In all modes of operation, Channel D Transmit Data is loaded in on the rising edge of TXCKC.</p> <p>TXCKA can optionally be used to clock in data for all of the input parallel transmit ports (TXDA, TXDB, TXDC, TXDD). When the TXCLK4 bit in PMC Control 2 Register is set to logic 0, all of the TXDy ports are sampled by a common clock, TXCKA. This configuration is required when operating in Trunking Mode.</p> <p>If this pin is not used, it should be tied to ground.</p>
TXDD[9] TXDD[8] TXDD[7] TXDD[6] TXDD[5] TXDD[4] TXDD[3] TXDD[2] TXDD[1] TXDD[0]	Input CMOS	B13 A13 B12 A12 B11 A11 B10 A10 B9 A9	<p>Parallel Transmit Data Backplane to primary or secondary channel D (PTDOD_P, PTDOD_N or STDOD_P, STDOD_N). This data can optionally be 8B/10B encoded. If encoded, Bits 9:0 of TXDD are defined as (Reserved Bit + K Bit + Data[7:0]). Data that appears here is provided in a SDR fashion regardless of operating mode.</p> <p>In all modes of operation, TXDD0 represents the first bit of the word that is transmitted on the differential pairs PTDOD_P, PTDOD_N and STDOD_P, STDOD_N.</p> <p>In all modes of operation, either TXCKD or TXCKA is used to load in data using its rising edges, depending on the state of control bit TXCLK4.</p> <p>If these pins are not used, they should be tied to</p>

Table 4 MDC/MDIO Pins

Pin Name	Type	Pin No.	Function
DVAD4 DVAD3 DVAD2 DVAD1 DVAD0	Input CMOS	D12 D11 P13 R13 R12	<p>SERDES Device Address. Pins DVAD[4:2] define the base device address of the QuadPHY 1G. Pins DVAD[1:0] are not used and should be tied to logic 0. The MDC/MDIO protocol addresses this device when the 3 MSBs of the PHYAD address match pins DVAD[4:2]. The two LSBs of the MDC/MDIO protocol PHYAD address point to the specific SERDES within the device.</p>

Pin Name	Type	Pin No.	Function
MDIO	Input/Output CMOS	J1	Management Data Input/Output. This terminal is the management interface (MI) serial port. During MI write cycles, input data is placed on this terminal and sampled by MDC. During a MI read cycle the MDIO terminal outputs management interface register information. Input data is sampled on the rising edge of MDC. Input and output data on this terminal is referenced to the rising edge of MDC. Note that MDIO should be externally pulled up to VDDQ with a 10kΩ resistor for proper operation between accesses.
MDC	Input CMOS	H3	Management Data Clock. Used to control data transfer to/from the management interface registers. Management interface input data is sampled on the rising edges of MDC. When data is to be output on the MDIO terminal it is referenced to the rising edge of MDC. MDC can be aperiodic. The presence of a clock on REFCLK is required for proper operation of the MDC/MDIO interface.

Table 5 Configuration/Status Pins

Pin Name	Type	Pin No.	Function
CV_DIS_EN	Input CMOS	J3	Code Violation/Disparity Error Code Enable (Active high). This static signal must be pulled high or low <u>prior</u> to deasserting RESET. Enables the error code option. If a code violation or disparity error is detected, the outputs RXD[9:0] are set to 1. This option requires that the decoder be enabled. This terminal is logically OR'd with the CODE_VIOL_DIS_ENABLE bit (Register 0x11). When not asserted, the CV bit indicates the disparity error.
DEC_ENC_EN	Input CMOS	J2	Decoder/Encoder Enable (Active high). This static signal must be pulled high or low <u>prior</u> to deasserting RESET. Enables the internal 8B/10B encoder/ decoder across all channels. When set to 0, the device processes 10B encoded data only. This terminal is logically OR'd with the INT_DEC_ENC_ENABLE(7) bit (Register 0x11); i.e., the INT_DEC_ENC_ENABLE(7) bit must be low in order for this pin to function.
EN_SLPBK	Input CMOS	D7	Enable Serial Data Loop-back (Active high). This static signal must be pulled high or low <u>prior</u> to deasserting RESET. Enables the loop-back function for serial data. When high, serial data is routed from the output of the serializer block to the input of the clock recovery block for each channel. The TDO_P/TDO_N serial outputs are held at a logical 1 state. The RDI_P/RDI_N serial inputs are ignored. Should be held low for normal operation.
SMRESET	Input Pulldown CMOS	L3	This active-high State Machine Reset signal provides an asynchronous QuadPHY 1G reset to all state machine flip flops. It has no affect on the PLL or the configuration and status flip flops accessible by the MDC/MDIO port. The minimum reset assertion time is typically less than 500 ns. This terminal is logically ORed with the Soft_Reset bit (Register 0x11) and provides the same functionality.

Pin Name	Type	Pin No.	Function										
INS_DEL_DIS	Input Pulldown CMOS	M3	Insert/Delete Disable. This static signal must be pulled high or low <u>prior</u> to deasserting RESET. When low, the QuadPHY 1G performs frequency compensation on incoming data. When high, frequency compensation is disabled.										
ENPLPBK	Input Pulldown CMOS	N3	Enable Parallel Loopback. This static signal must be pulled high or low <u>prior</u> to deasserting RESET. When high, the QuadPHY 1G internally connects all receive channel parallel ports to their corresponding transmit parallel ports. Data is still sent to the parallel outputs. When low, this connection is broken.										
GEMOD	Input Pulldown CMOS	C8	<p>Gigabit Ethernet Mode (active high)</p> <p>When asserted, the chip will:</p> <ol style="list-style-type: none"> Configuration words that pass through the PHY during the Auto-Negotiation process may be inserted/deleted for frequency compensation /K28.5/ followed by any non-K character are recognized as an IDLE sequence which can be inserted or deleted for frequency compensation (except when BMOD is asserted, chip will treat /K28.5/D10.1/ as described in BMOD pin description) Modify IDLE to correct disparity by substituting /D5.6/ for /D16.2/ in a /K28.5/ Dx.y/ transmit IDLE pair. <p>GEMOD is OR'd with GE_REG. PCS_ENABLE must be set to 0 when GE_REG = 1. See Register 0x18, Bit 15 for additional information.</p> <p>This static signal must be pulled high or low <u>prior</u> to deasserting RESET.</p>										
BMOD	Input Pulldown CMOS	P9	Busy Bit Mode , active high. This static signal must be pulled high or low <u>prior</u> to deasserting RESET. When asserted, the K28.5/D10.1 adjacent pair will be treated as valid data and passed through the FIFO. When deasserted, it will be treated as an IDLE sequence and can be deleted. This pin is valid only when GEMOD is asserted. BMOD is OR'ed with BUSY_REG.										
MODE1 MODE0	Input CMOS	P12 P11	<p>Mode Selector bits. This static signal must be pulled high or low <u>prior</u> to deasserting RESET. The MODE[1:0] input selects the interface mode according to the table below. Also see Register 0x11.</p> <table border="1"> <thead> <tr> <th>Mode</th> <th>Description</th> </tr> </thead> <tbody> <tr> <td>00</td> <td>Locally Referenced Receive Clock (LRRC) Mode</td> </tr> <tr> <td>01</td> <td>Trunking Mode</td> </tr> <tr> <td>10</td> <td>Remotely Referenced Receive Clock (RRRC) Mode</td> </tr> <tr> <td>11</td> <td>Half-rate Receive Clock (HRRC) Mode</td> </tr> </tbody> </table>	Mode	Description	00	Locally Referenced Receive Clock (LRRC) Mode	01	Trunking Mode	10	Remotely Referenced Receive Clock (RRRC) Mode	11	Half-rate Receive Clock (HRRC) Mode
Mode	Description												
00	Locally Referenced Receive Clock (LRRC) Mode												
01	Trunking Mode												
10	Remotely Referenced Receive Clock (RRRC) Mode												
11	Half-rate Receive Clock (HRRC) Mode												

Pin Name	Type	Pin No.	Function
REFCLK	Input CMOS	C12	<p>Reference Clock. Requires an accurate, low jitter, 100 ppm for frequencies between 93.3 and 125 MHz reference clock. The clock synthesis PLL uses REFCLK to generate a phase locked 10X internal clock. The PLL expects an uninterrupted reference clock. If the reference clock is disrupted for any duration of time, a hardware reset maybe necessary to allow the PLL to fully recover.</p> <p>REFCLK is referenced to VDDQ voltage levels (see the D.C Characteristics Section for details about Vol and Voh logic thresholds).</p> <p>The presence of a clock on REFCLK is required for proper operation of the MDC/MDIO interface.</p>
PLL_LOCK	Output CMOS	R11	<p>PLL Lock is an external indication that the internal clock synthesis PLL has locked to REFCLK.</p>
RESET	Input CMOS	G3	<p>The active-high Reset (RESET) signal provides an asynchronous QuadPHY 1G reset to all flip-flops. The minimum reset assertion time is 500 ns.</p>

Table 6 JTAG Pins

Pin Name	Type	Pin No.	Function
TCK	Input CMOS	C10	<p>The Test Clock (TCK) signal provides timing for test operations that are carried out using the IEEE P1149.1 test access port.</p>
TDI	Input CMOS Pullup	C9	<p>The Test Data Input (TDI) signal carries test data into the QuadPHY 1G via the IEEE P1149.1 test access port. TDI is sampled on the rising edge of TCK. TDI has an integral pull-up resistor.</p>
TMS	Input Pullup CMOS	C11	<p>The Test Mode Select (TMS) signal controls the test operations that are carried out using the IEEE P1149.1 test access port. TMS is sampled on the rising edge of TCK. TMS has an integral pull-up resistor.</p>
TRSTB	Input CMOS	D8	<p>The active-low Test Reset (TRSTB) signal provides an asynchronous QuadPHY 1G test access port reset via the IEEE P1149.1 test access port. TRSTB must be pulled low during normal device operation. This places the JTAG logic into the reset state.</p>
TDO	Output Tristate CMOS	C7	<p>The Test Data Output (TDO) signal carries test data out of the QuadPHY 1G via the IEEE P1149.1 test access port. TDO is updated on the falling edge of TCK. TDO is a tristate output which is inactive except when scanning of data is in progress.</p>

Table 7 Miscellaneous Pins

Pin Name	Type	Pin No.	Function
NC	No Connect	D4 D5 D6 D9 D10 F3 P5 P6 P7 P8 P10	Not Connected. These pins should be left floating.
POEN	Input CMOS	D13	Parallel Output Enable (active high). Tristates all the parallel output data drivers (RXDxy[9:0]) and clock drivers (RXCx) when low.
TEST_EN	Input Pulldown CMOS	K3	Reserved for PMC Test Purposes. Must be left unconnected.
RPRES	Analog Bias	C13	Terminal for a Precision Resistor of 10k 1% reference resistor is connected between this terminal and ground. This sets the internal reference current sources.

Table 8 Digital Power and Digital Ground Pins

Pin Name	Type	Pin No.	Function
VDD	Power Digital Core	E10 E11 E12 E13 F13 G13 H13 J13 K13 L13 M13 N13 N12 N11 N10	Digital core power. This is, $V_{DD} = 1.8 V \pm 5\%$, for the digital core logic.

Pin Name	Type	Pin No.	Function
VDDQ	Power Digital I/O	E9 E8 E7 E6 E5 F5 G5 H5 J5 K5 L5 M5 N5 N6 N7 N8 N9	Digital I/O power.

Pin Name	Type	Pin No.	Function
GND	Ground Digital	E4 F4 G4 H4 J4 K4 L4 M4 N4 A14 B14 C14 D14 E14 F14 G14 H14 K14 L14 M14 N14 P14 R14 T14 U14 A17 B17 C17 D17 E17 F17 G17 H17 K17 L17 M17 N17 P17 R17 T17 U17	Digital ground.

Pin Name	Type	Pin No.	Function
T_GND	Ground Digital Thermal	F6 F7 F8 F9 F10 F11 F12 G6 G7 G8 G9 G10 G11 G12 H6 H7 H8 H9 H10 H11 H12 J6 J7 J8 J9 J10 J11 J12 K6 K7 K8 K9 K10 K11 K12 L6 L7 L8 L9 L10 L11 L12 M6 M7 M8 M9 M10 M11 M12	Thermal ground. Used as a ground pin and to conduct heat away from the part and into the PCB. This ground should be attached to the same ground plane as GND.

Table 9 Analog Power and Ground Pins

Pin Name	Type	Pin No.	Function
VDDA	Power Analog	J14 J15	Analog Power. This is, $V_{DDA} = 1.8\text{ V} \pm 5\%$ and must be separated from digital power.
GND A	Ground Analog	J16 J17	Analog ground. Connect to same ground plane as GND pins.

Notes:

1. All QuadPHY 1G inputs and bi-directionals present minimum capacitive loading and operate at CMOS logic levels.
2. Digital and analog ground pins are not connected together internally. Failure to connect any of these pins can cause malfunction or damage to the QuadPHY 1G.
3. Digital and analog power pins are not connected together internally. Failure to connect any of these pins could also result in malfunction or damage to the QuadPHY 1G.

10 Functional Description

10.1 Modes of Operation

The QuadPHY 1G has five modes of operation:

- Locally Referenced Receive Clock (LRRC) Mode
- Trunking Mode
- Remotely Referenced Receive Clock (RRRC) Mode
- Half-rate Receive Clock (HRRC) Mode
- Parallel Loopback Mode

LRRC, Trunking, and Parallel Loopback modes use the channel Receive FIFOs to synchronize the received data to the local clock domain (REFCLK). The LRRC and Trunking Modes configure the Parallel Receive and Transmit Interface into four 10-bit Single Data Rate (SDR) Ports.

RRRC Mode bypasses the channel Receive FIFOs, which enables all four channels to operate independently with their own recovered clock and data. RRRC Mode configures the Parallel Receive and Transmit Interface into four 10-bit Single Data Rate (SDR) Ports.

HRRC Mode also bypasses the channel Receive FIFOs, which enables all four channels to operate independently with their own recovered clock and data. HRRC Mode configures the Parallel Receive Interface into four 10-bit Dual Data Rate (DDR) Ports, each having their own common and complimentary half rate receive clocks. The Transmit Interface is configured as four 10-bit Single Data Rate (SDR) Ports with full rate transmit clocks.

When the QuadPHY 1G is configured in LRRC, Trunking, or Parallel Loopback Mode, the Receive FIFO is enabled to synchronize the incoming serial data to the local clock domain determined by REFCLK. While operating in these modes, the QuadPHY 1G can be programmed to perform frequency compensation on a channel by channel basis, as well as Trunking across all four serial channels. Trunking allows the QuadPHY 1G to remove the skew (delay differences) between the 4 serial receive channels to enable the device to operate as a single 4 Gbit/s logical channel (when REFCLK = 125 MHz).

When the QuadPHY 1G is configured in RRRC or HRRC Mode, the Receive FIFO is bypassed. In these modes, all four channels operate independently with their own recovered clock and data on a dedicated set of terminals. Since this mode provides a recovered clock per channel, the frequency difference between REFCLK and recovered clock (receive data rate) is limited only by the capture range of the clock recovery circuit. The QuadPHY 1G clock recovery circuit can tolerate frequency differences of ± 200 ppm of the REFCLK frequency (with no packet size or IPG restriction). This mode provides the lowest possible latency since the internal Receive FIFOs are bypassed.

10.1.1 Locally Recovered Receive Clock (LRRC) Mode

LRRC Mode uses the Receive FIFOs to transfer data from the recovered clock domain to the local (REFCLK) clock domain on all four channels. To activate this mode, the MODE pins must be set to logic 00. In this mode, the four channels of high-speed receive data coming into the QuadPHY 1G can be sourced from different clocks by the QuadPHY 1G's link partners. Figure 6 illustrates the receive data path for LRRC Mode. It shows the data path from one of the QuadPHY 1G's 4 high-speed serial input channels to one of its 10-bit parallel receive output port. The RBCD1 and RBCD0 are common across all 4 parallel ports.

Figure 6 LRRC Mode Receive Data Path

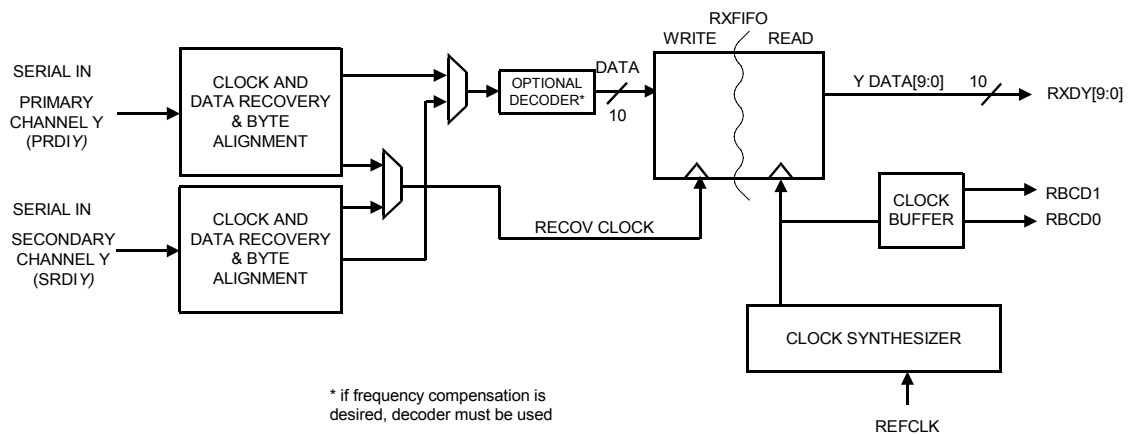

Table 10 defines the Mode Options for LRRC Mode. In **Mode Option 1**, the `INS_DEL_DIS` is set to a logic 0 which allows idle patterns to be inserted or deleted into the Receive FIFO to compensate for clock rate differences and `DEC_ENC_EN` is set to a logic 1 which enables the internal 8B/10B encoder/decoder. In **Mode Option 2**, the `INS_DEL_DIS` is set to a logic 1 which disables the inserts and deletes of idles in the Receive FIFO. This can be done in synchronous systems that guarantee that the clock that sourced the serial receive data is the same as the REFCLK. In **Mode Option 3**, `DEC_ENC_EN` is set to a logic 0 and `INS_DEL_DIS` is set to a logic 1. This allows 10B data to be passed through the Receive FIFO to the parallel outputs, in a synchronous system. In **Mode Option 4**, `PCS_ENABLE` is set to a logic 1, `INS_DEL_DIS` is set to a logic 0, and `DEC_ENC_EN` is set to a logic 1. This enables full duplex PCS functionality with frequency compensation.

Table 10 LRRC Mode Options

Option	Parallel Interface	LRRC Mode (MODE[1:0] = 00) Channel data are sampled on the positive edge of RBCD1 and TXCK. One 10-bit data port supports a single channel.	RX interface			Pin Settings								
			FIFOs	RXCLK(s)	Frequency	MODE1	MODE0	DEC_ENC_EN	GEMOD	BMOD	PCS_ENABLE (Config Bit Only)	INS_DEL_DIS	ENPLPBK	
1	8B	With frequency compensation												
		<u>Receive</u> RXDY[7:0] = 8-bit data RXDY 8 = K bit RXDY 9 = code violation bit <u>Transmit</u> TXDY [7:0] = 8-bit data TXDY 8 = K bit TXDY 9 = reserved	on	1	f _{REFCLK}	0	0	1	*	*	0	0	0	
2	8B	Without frequency compensation												
		Same as option 1 except the Receive FIFO insert/delete function is disabled. The REFCLK signals of the remote transmit PHY and local receiving PHY must be synchronous.	on	1	f _{REFCLK}	0	0	1	*	*	0	1	0	
3	10B	Without frequency compensation												
		<u>Receive</u> RXDY [9:0] = 10-bit block encoded data <u>Transmit</u> TXDY [9:0] = 10-bit block encoded data	on	1	f _{REFCLK}	0	0	0	0	0	0	1	0	
4	PCS	Full Duplex PCS with frequency compensation												
		<u>Receive</u> RXDY [7:0] = 8-bit data RXDY 8 = RX_DV RXDY 9 = RX_ER <u>Transmit</u> TXDY [7:0] = 8 bit data TXDY 8 = TX_EN TXDY 9 = TX_ER	on	1	f _{REFCLK}	0	0	1	0	0	1	0	0	

* Optional: Processing of Gigabit Ethernet data via GEMOD=1 (and optionally busy bit via BMOD=1), otherwise should be set to zero.

10.1.2 Trunking Mode

Trunking Mode operation is identical to LRRC Mode, except that it also compensates for differences in wire length between channels and allows the QuadPHY 1G to appear to operate as a single 4 Gbit/s logical channel (when REFCLK = 125 MHz). To activate this mode, the MODE pins must be set to logic 01. The Trunking process removes the skew (delay differences) between serial channels so that eight bytes transmitted together are aligned by the receiving device. This is achieved by sensing alignment information on each channel that identifies bytes to be aligned. All four transmit channels are synchronous to each other and must be within ± 200 ppm of the receive device's REFCLK. Refer to the Receive FIFO description under section 10.3.4 Receive Path for a detailed explanation of the Trunking process.

This mode combines the four serial streams into a single high bandwidth channel across four channels in each direction. On the parallel side of the chip, the four ports are combined into forty bit wide, transmit and receive, SDR interfaces. A common complementary clock (RBCD1, RBCD0) is output as a reference for the received data. A common transmit clock, TXCKA, must be used to clock the TXDy[9:0] input data when operating in Trunking Mode. TXCKA is used in this manner when the TXCLK4 bit in the PMC Control 2 Register is set to logic 0 (default state). TXCKA must be synchronous to REFCLK in this mode.

The execution of a soft reset is recommended after the PLL has locked while operating in Trunking Mode.

It is possible to use fewer than 4 channels when operating in trunking mode, however the unused channels must be disabled through Register 0x10 (PMC Control Register 1).

Table 10 defines the Trunking Mode Options for Trunking Mode. Trunking Mode is not functional when the PCS logic is enabled, or when the GEMOD is set to a logic 1 or when DEC_ENC_EN is set to a logic 0. In **Mode Option 1**, the INS_DEL_DIS is set to a logic 0, which allows idle patterns to be inserted or deleted into the Receive FIFO to compensate for clock rate differences and. In **Mode Option 2**, the INS_DEL_DIS is set to a logic 1, which disables the inserts and deletes of idles in the Receive FIFO. This can only be done in synchronous systems that guarantee that the clock that sourced the serial receive data is the same as the REFCLK.

Table 11 Trunking Mode Options

Option	Parallel Interface	Trunking Mode (MODE[1:0] = 01) Trunking aligns all four lanes to create a high bandwidth data channel. A 10-bit parallel port services each lane. Data for each lane is sampled on the rising of RBCD1 and TXCK.	RX Interface			Pin Settings							
			FIFOs	RBC(s)	Frequency	MODE1	MODE0	DEC_ENC_EN	GEMOD	BMOD	PCS_ENABLE (Config Bit Only)	INS_DEL_DIS	ENLPBK
1	8B	With frequency compensation											
		<u>Receive</u> RXDY [7:0] = 8-bit data RXDY 8 = K bit RXDY 9 = code violation bit <u>Transmit</u> TXDY [7:0] = 8-bit data TXDY 8 = K bit TXDY 9 = reserved	on	1	f_{REFCLK}	0	1	1	0	0	0	0	0
2	8B	Without frequency compensation											
		<u>Receive</u> RXDY [7:0] = 8-bit data RXDY 8 = K bit RXDY 9 = code violation bit <u>Transmit</u> TXDY [7:0] = 8-bit data TXDY 8 = K bit TXDY 9 = reserved	on	1	f_{REFCLK}	0	1	1	0	0	0	1	0

10.1.3 Remotely Referenced Receive Clock (RRRC) Mode

In RRRC Mode all four channels operate independently with their own recovered clock and data. Since this mode does not use the Receive FIFOs, the frequency difference between REFCLK and recovered clock (receive data rate) is limited only by the capture range of the clock recovery circuit. Therefore, the QuadPHY 1G can tolerate frequency differences of ± 200 ppm of the REFCLK frequency (with no packet size or IPG restriction). This mode provides the lowest possible latency since the internal Receive FIFOs are bypassed.

Figure 7 illustrates the receive data path for RRRC Mode. It documents the data path from 1 of the QuadPHY 1G's 4 high-speed serial input channels to one of its 10-bit SDR parallel receive output ports.

Figure 7 RRRC Mode Receive Data Path

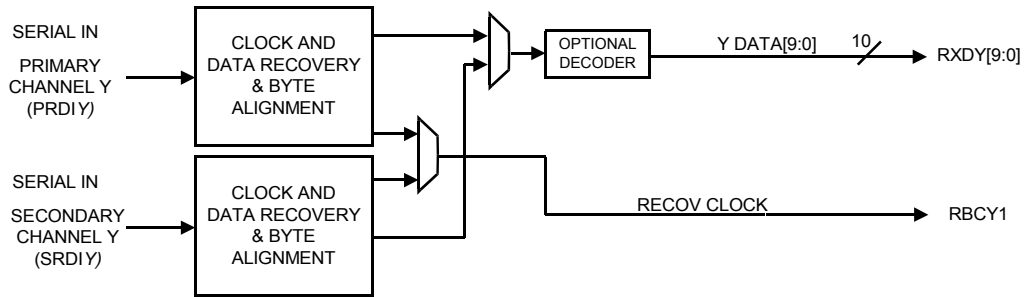

Table 12 defines the Mode Options for RRRC Mode. The `INS_DEL_DIS` is automatically disabled while in RRRC Mode. To activate this mode, the `MODE` pins must be set to logic 10. In **Mode Option 1**, `DEC_ENC_EN` is set to a logic 1, which enables the internal 8B/10B encoder/decoder. In **Mode Option 2**, `DEC_ENC_EN` is set to a logic 0, which disables the internal 8B/10B encoder/decoder. In **Mode Option 3**, `PCS_ENABLE` is set to a logic 1 and `DEC_ENC_EN` is set to a logic 1. This enables full duplex PCS functionality.

Table 12 RRRC Mode Options

Option	Parallel Interface	RRRC Mode (<code>MODE[1:0] = 10</code>) Channel data are sampled on the rising edge of the byte clock, <code>RBCY1</code> . Each 10-bit data port supports a single channel.	RX interface			Pin Settings								
			FIFOs	RBC(s)	Frequency	MODE1	MODE0	DEC_ENC_EN	GEMOD	BMOD	PCS_ENABLE (Conf Bit only)	INS_DEL_DIS	ENPLPBK	
1	8B	8B/10B Encoder/Decoder Enabled												
		<u>Receive</u> <code>RXD Y [7:0] = 8 bit data</code> <code>RXD Y [8] = K bit</code> <code>RXD Y [9] = code violation bit</code> <u>Transmit</u> <code>TXD Y [7:0] = 8 bit data</code> <code>TXD Y [8] = K bit</code> <code>TXD Y [9] = reserved</code>	off	4	$f_{\text{recoveredclk}}$	1	0	1	*	*	0	X	0	
2	10B	8B/10B Encoder/Decoder Disabled												
		<u>Receive</u> <code>RXD Y [9:0] = 10-bit block encoded data</code> <u>Transmit</u> <code>TXD Y [9:0] = 10-bit block encoded data</code>	off	4	$f_{\text{recoveredclk}}$	1	0	0	0	0	0	X	0	

3	PCS	Full Duplex PCS												
		<u>Receive</u> RXD Y[7:0] = 8 bit data RXD Y[8] = RX_DV RXDY[9] = RX_ER <u>Transmit</u> TXD Y[7:0] = 8 bit data TXD Y[8] = TX_EN TXD Y[9] = TX_ER	off	4	f _{recoveredclk}	1	0	1	0	0	1	X	0	

*Optional : Processing of Gigabit Ethernet data via GEMOD=1(and optionally Busy Bit via BMOD=1)
Otherwise should be set to 0

10.1.4 Half Rate Receive Clock (HRRC) Mode

The Half Rate Receive Clock (HRRC) Mode maps four channels of serial data to four ports. The receive clocks are derived from the remote reference clock of each remote transmitter. The transmit clock is input from a local source. Each port consists of a 10-bit receive data output bus and a 10-bit transmit input data bus. A half rate complementary receive clock pair (RBCD1/RBCD0, RBCC1/RBCC0, RBCB1/RBCB0, RBCA1/RBCA0) is used as a reference for each receive data port. A full-rate transmit clock for the four ports can be a single common clock (TXCKA) or four individual transmit clocks, (TXCKD, TXCKC, TXCKB, or TXCKA).

HRRC allows all four channels to operate independently with its own recovered clock and data on a dedicated set of terminals. Frequency differences of ± 200 ppm¹ of the REFCLK frequency can be tolerated.

Figure 8 illustrates the receive data path for HRRC Mode. It documents the data path from 1 of the QuadPHY 1G's 4 high-speed serial input channels to one of its 10-bit DDR parallel receive output ports.

The internal 8B/10B Encoder/Decoder and the PCS Logic must be disabled while operating in HRRC Mode. When PCS logic is disabled the PM8354 will not keep track of even and odd byte locations. If the interfacing logic is implementing the PCS functions this logic will also have to keep track of even and odd byte locations as commas are expected to be sent in even byte locations. If PCS functionality is not part of the system the PM8354 does not impose any restrictions regarding byte positions.

Figure 8 Receive Data Path for HRRC Mode

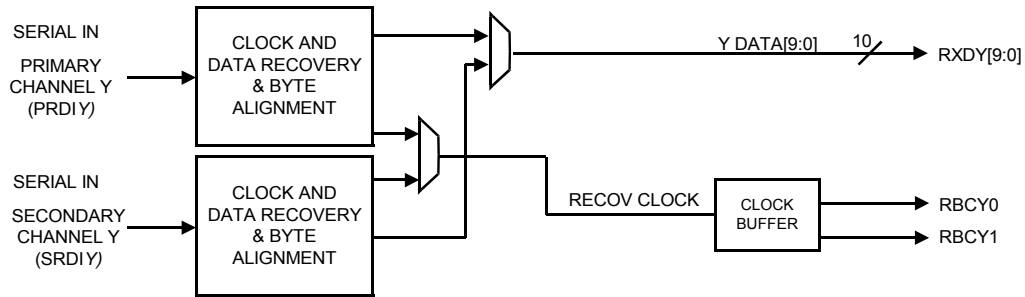

Table 13 defines the Mode Options for HRRC Mode. The INS_DEL_DIS is automatically disabled while in HRRC Mode. To activate this mode, the MODE pins must be set to logic 11. In **Mode Option 1**, DEC_ENC_EN is set to a logic 0, which disables the internal 8B/10B encoder/decoder.

Table 13 HRRC Mode Options

Option	Parallel Interface	HRRC Mode (MODE[1:0] = 11) Channel data are sampled on both edges of the half rate byte clock, RBCx1. (RBCx0 is the complementary clock) Each 10-bit data port supports a single channel.	RX interface			Pin Settings								
			FIFOs	RBC(s)	Frequency	MODE1	MODE0	DEC_ENC_EN	GEMOD	BMOD	PCS_ENABLE (Conf Bit only)	INS_DEL_DIS	ENPLPBK	
1	10B	8B/10B Encoder/Decoder Disabled												
		<u>Receive</u> RXDY [9:0] = 10-bit block encoded data <u>Transmit</u> TXD Y [9:0] = 10-bit block encoded data	off	8	$f_{\text{recoveredclk}}$	1	1	0	0	0	0	X	0	

10.1.5 Parallel Loopback Mode

Parallel Loopback Mode provides a means to transmit a serial data stream on the high-speed transmit outputs (TDO) that has been received on the high-speed receive inputs (RDI) without external intervention. This is useful to retime serial data streams or for diagnostic/test purposes. Figure 9 shows the data path for a channel that is configured in Parallel Loopback Mode.

It is important to note that during internal serial data loopback testing, channel loopback enable bits in the Loopback control register must be coordinated with the redundancy control register's channel select bits so that transmit primary and secondary channels are paired with their receive channel counterparts.

10.3 Serial Channel Overview

The QuadPHY 1G uses high-speed serial channel technology to communicate data between chips. Each channel consists of a differential transmit pair and a differential receive pair. The device supports PECL voltage swings and the receiver inputs are designed to be capacitively coupled external to the device. A clock is embedded in the serial data stream at the transmitter and extracted at the receiver, where it is used to recover the data. Data is de-serialized, decoded and processed internally as 9 bit bytes (8 data bits and 1 control bit) plus decode error indication. In Trunking Mode, up to 4 such groups of data are bound together into a single 64-bit wide data path supported by accompanying control signals.

The QuadPHY 1G requires that received data to be 8B/10B encoded to ensure sufficient transition density. The QuadPHY 1G's internal 8B/10B encoder/decoder can be disabled if an external 8B/10B encoder/decoder is used. The 8B/10B coding method offers several advantages including high-transition density, low DC offset and availability of special control characters (see Section 10.3.1).

10.3.1 8B Code Group Bit Mappings

All QuadPHY 1G registers that contain 8B code groups adhere to the following convention:

- Bit0, the LSB – contains the A-bit of the code group
- Bit7, the MSB – contains the H-bit of the code group
- Bit8, contains the k-bit (if applicable)

Table 14 identifies the valid control code groups that will encode/decode properly. Do not specify any other control code groups in the QuadPHY 1G registers or apply these code groups to the TXDxy[8:0] interface.

Table 14 Valid K Bit Values

K-Bit	Valid 9-bit Value (hex)	Code	Definition
K28.0	0x11C	/R/ ¹	Suggested Skip/Replace Idle Character
K28.1	0x13C		Alternate Skip/Replace Idle Character
K28.2	0x15C		Alternate Skip/Replace Idle Character
K28.3	0x17C	/A/	Suggested Alignment Idle Character
K28.4	0x19C		Alternate Skip/Replace Idle Character
K28.5	0x1BC	/K/	Synchronization Idle Character
K28.6	0x1DC		Alternate Skip/Replace Idle Character
K28.7	0x1FC		Special Diagnostics Character ²
K23.7	0x1F7	/R/	Carrier-Extend for 1000BaseX PCS Apps
K27.7	0x1FB	/S/	Start-of-Packet
K29.7	0x1FD	/T/	End-of-Packet
K30.7	0x1FE	/V/	Error Propagation

Note:

1. Refer to Table 48-4 Defined ordered_sets and special code groups in the IEEE Draft P802.3-2000.
2. This character is not to be used as part of normal transmission data. Please see section 36.2.4.9 in IEEE 802.3 for further details.

For backplane applications, the usage of these characters is not limited by the QuadPHY 1G. Any characters not used as Alignment or Idle characters will be passed transparently between QuadPHY 1G devices.

For Gigabit Ethernet applications, these characters must be used in a manner consistent with the 802.3 specification.

10.3.2 Clock Synthesizer

The Clock Synthesizer uses a PLL to synthesize a clock from the REFCLK input. The frequency of the PLL clock is 10 times the frequency of REFCLK, and a single synthesized clock is used to transmit serial data on all 4 transmit channels.

The PLL clock frequency can be varied over a range of 1.0 GHz to 1.25 GHz by changing the frequency of REFCLK. The PLL has a fixed multiplication ratio of 10, so the frequency of REFCLK must be 1/10 the required PLL clock frequency as illustrated in Table 15.

The PLL in the Clock Synthesizer requires a 10 k $\Omega \pm 1\%$ precision resistor on the RPRES terminal.

Table 15 Example REFCLK and PLL Clock Combinations

REFCLK Frequency	Multiplier	PLL Clock Frequency	Transmit Data Rate
93.3 MHz	10x	933MHz	933 Mbit/s
106.25 MHz	10X	1.0625 GHz	1.0625 Gbit/s
125 MHz	10X	1.25 GHz	1.25 Gbit/s

10.3.3 Transmit Path

The QuadPHY 1G contains four transmit channels. Each channel consists of a SDR Parallel Interface, Transmit FIFO, Transmit PCS, 8B/10B Encoder, and Serializer. The configuration of these functional block is shown in Figure 10.

The device can accept 8-bit plus control bit, GMII formatted data, or 10-bit coded data on the TXDy ports. The data must be frequency synchronous with REFCLK. The 8B/10B encoder and PCS logic may be bypassed depending on the type of data presented.

Figure 10 Transmit Channel Functional Blocks

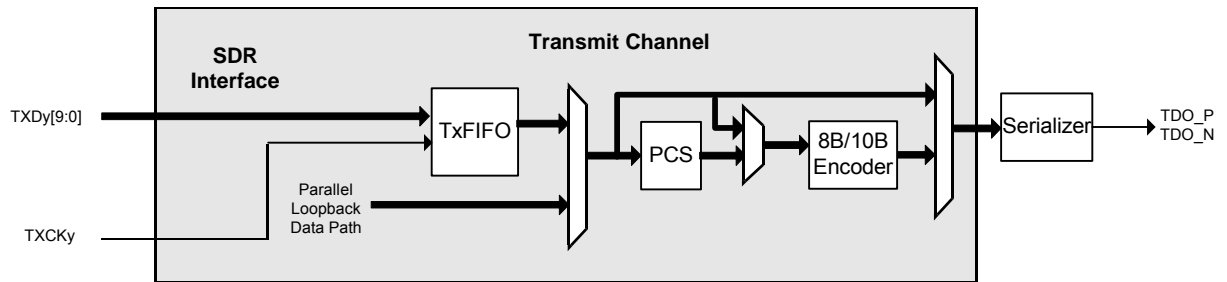

SDR Parallel Interface

The transmit parallel interface consists of 40 data pins that are divided across the four transmit channels. Channel’s A, B, C, and D each use 10 pins. The pins are utilized by applying the input data in a Single-Data Rate (SDR) fashion, that is, data is applied on the rising edges of the transmit clock. The parallel transmit interface is employed as a SDR interface for all operational modes of the QuadPHY 1G. There are 10 data bits dedicated to each channel. The transmit data for each channel is sampled on the rising edge of the corresponding transmit clock. This is depicted in Figure 11, where y refers to A, B, C or D.

Figure 11 Transmit Timing

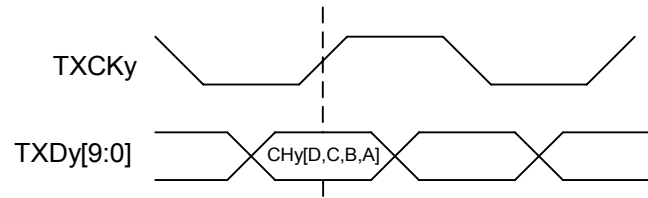

The device may be configured so that each TXDy port has its own clock or so that all four share a common clock.

When the TXCLK4 bit in PMC Control 2 Register is set to logic 0, all of the TXDy ports are sampled by a common clock, TXCKA.

When the TXCLK4 bit is set to logic 1, TXCKA samples TXDA, TXCKB samples TXDB, TXCKC samples TXDC and TXCKD samples TXDD. Clocks TXCKA, TXCKB, TXCKC, and TXCKD must all be synchronous to REFCLK, but the phase of each clock can be different. The Transmit FIFO will account for the phase differences (see the Transmit FIFO description for addition details). The transmit data can be 10B encoded data if the encoder is disabled, 8B data plus K control bit if the encoder is enabled, or 8 bits of data (TXD) plus TX_EN and TX_ER for Gigabit Ethernet applications

While operating in Trunking mode, one common clock, TXCKA, must be used to clock all 4 TXDy[9:0] input busses. This requires that the TXCLK4 bit be set to logic 0. Table 16 describes the mapping of data bits to the transmit data ports. When the encoder is disabled, the 10B word is mapped to a TBI (Ten-Bit Interface) and is generally described by “abcdeifghj” where “a” is the least significant bit and serialized onto the wire first and “j” is the most significant bit. When the encoder is enabled, the 8B word is represented by “HGFEDCBA” where “H” is the most significant bit and “A” is the least significant bit, and the control value is “K”. When the PCS logic is enabled, the transmit data is mapped to GMII signals. When the encoder is enabled, the transmit date is 10B encoded internally and is generally described by “abcdeifghj” where “a” is the least significant bit and serialized onto the wire first and “j” is the most significant bit.

Table 16 Parallel Transmit Interface Pin Mapping

	10B Transmit Data	8B Transmit Data	GMII DATA
TXDy9	j	TIE LOW	TX_ER
TXDy8	h	K	TX_EN
TXDy7	g	H	TXD7
TXDy6	f	G	TXD6
TXDy5	i	F	TXD5
TXDy4	e	E	TXD4
TXDy3	d	D	TXD3
TXDy2	c	C	TXD2
TXDy1	b	B	TXD1
TXDy0	a	A	TXD0

Transmit FIFO

The Transmit FIFO is a 6-word by 10-bit FIFO that transfers data from the TXCKy domain to the internal clock domain that is synchronous to REFCLK. The TXCKy and the REFCLK must be synchronous. Once an arbitrary phase relationship is established, the phase deviation must not vary by more than ± 500 ps. Should the phase change more than ± 500 ps, momentary corruption of data may occur.

Transmit PCS

The QuadPHY 1G supports the 1000Base-X PCS for full-duplex applications. Note that carrier sense (CRS) and collision detect (COL) are not supported per *IEEE 802.3-2000* standard. The PCS functionality is enabled by setting the PCS_ENABLE bit in PMC Control 2 Register to logic 1 and the INT_DEC_ENC_ENABLE bit in PMC Control 2 Register or the DEC_ENC_EN pin to logic 1.

The PCS transmit logic contains an 8B/10B encoder and a single transmit state machine whose operation is consistent with the operation of the two transmit state machines that run in unison within clause 36 of *IEEE 802.3-2000*. All transmit blocks are compliant with the *IEEE 802.3-2000* (Clauses 36 and 37).

8B/10B Encoder

When enabled, the encoder accepts an 8-bit word plus the k-bit and encodes these bits into a 10-bit parallel code. The encoder generates a running disparity for its own use in generating sub-blocks of 6- and 4-bit codes that limit the run length and maintain DC balance of the serialized bits. The user can present data as an un-encoded byte along with a control signal indicating a "K" character, or can disable the encoding logic and present pre-encoded 10-bit data. The Encoder logic is enabled either by connecting the DEC_ENC_EN pin to logic 1 or programming PMC Control 2 Register, bit 7 (INT_DEC_ENC_ENABLE) with logic value 1. Rules for encoding are specified in *IEEE 802.3-2000*.

When the encoder is enabled and input pin GEMOD or PMC Control 3 Register, bit 15 (GE_REG) is set to logic 1 and PMC Control 2 Register, bit 2 (PCS_ENABLE) is set to logic 0, the encoder will substitute a D5.6 octet for a D16.2 octet when it follows a K28.5 character and the current running disparity is negative. This functionality is useful when the input data stream is generated from a 1000Base-X PCS Transmit state machine and the current running disparity during Interpacket Gap (IPG) must be maintained such that positive commas are encoded.

In Trunking Mode, the encoder can also substitute an alignment character, the octet value programmed into the A_CHAR bits in the Trunking Control Register, for the second octet of an idle sequence (idle sequences are defined in registers 0x12, and 0x13, and 0x14 and 0x15) when the INSERT_A_CHAR register bit in the Trunking Control register is set to logic 1. All channels being trunked must currently be transmitting the same idle sequence for the second half of the idle to be replaced. Idles will be replaced by the A_CHAR register value at a frequency determined by the A_DELAY bits in the Trunking Control register.

Serializer

The serializer accepts 10-bit transmission characters and converts them from a parallel format to a serial bit stream at bit rates between 933 Mbit/s and 1.25 Gbit/s. The serializer accepts a 10-bit parallel word with the least significant bit being transmitted first.

10.3.4 Receive Path

The QuadPHY 1G contains four receive channels. Each channel consists of a Clock and Data Recovery Unit (CDRU), Byte Alignment logic, 8/B/10B Decoder, Receive PCS, Receive FIFO, and a SDR/DDR Parallel Output Interface. The configuration of these functional blocks are shown in Figure 12.

Figure 12 Receive Channel Functional Blocks

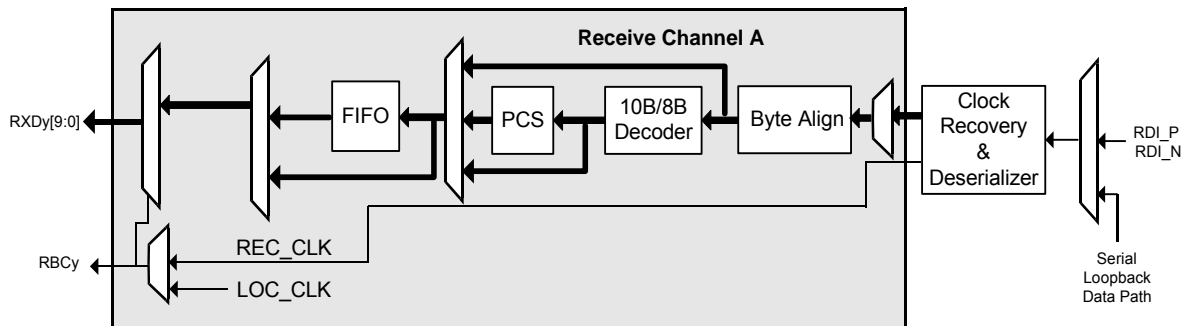

Each channel's CDRU, comma detection and byte alignment logic run independently. The comma detection logic is programmable to detect +comma, -comma, or both. The decoded words with K bits are optionally retimed by the Receive FIFO with IDLE character insertion/deletion for frequency compensation. The four channels are also optionally column aligned to /A/, alignment character as programmed into the Trunking Control register, or idle to data transitions across the four channels.

The receiver input data must be AC coupled with a transfer rate between 933 Mbits/s and 1.25 Gbit/s. The QuadPHY 1G supports on-chip 100Ω differential termination. The data is expected to be a 10-bit encoded data stream as specified in *IEEE 802.3-2000*. The clock recovery circuit recovers a clock (REC_CLK) from the incoming data. The recovered clock is used to sample the data. Both the recovered clock and data are provided to the deserializer independently for each channel.

Serial input ports may be internally looped-back to the serial output ports for testing purposes. While in a serial loopback mode, the serial output pins are held at a differential one. Serial loopback may be enabled using one of the following mechanisms:

- Assert INT_EN_PRI_SERIAL_LPBK/INT_EN_SEC_SERIAL_LPBK control bit in the Loopback Control Register
- Assert Loopback bit in the channel's GMII Control register
- Assert EN_SLPBK pin to loopback all channels simultaneously

When the CODE_VIOL_DIS_ENABLE (bit 14 PMC Control 2) bit is set or the CV_DIS_EN pin is asserted, a code or disparity violation detected by the receiver will replace the byte in violation by the encoding of all 1's or 0xFF on the data pins and a 1 on the K bit and the associated code error counter is incremented. The error code is propagated through QuadPHY 1G and eventually transmitted at the egress.

Clock and Data Recovery

A 933 Mbit/s to 1.25 Gbit/s receive clock is extracted from the 10-bit coded serial data stream independently on each channel. The data rate of the received serial bit stream should be between 933 Mbit/s and 1.25 Gbit/s to guarantee proper lock. The receive clock locks to the input within 2 μS after a valid input data stream is applied. The received data is de-serialized and byte aligned. The recovered clock will be synchronous to the REFCLK if no data is present on the RDI serial inputs. The de-serializer converts the received serial stream into 10-bit parallel data.

The bit synchronization time, the time required for the Clock and Data Recovery unit to recover the incoming bitstream error-free, is influenced by several factors including:

- Receive jitter.
- Relative phase difference between the incoming bitstream and the signal to which the CDRU was previously synchronized.
- Transition density.
- DC Common Mode voltage offsets

The bit synchronization time is independent of the ppm offset, but the incoming bitstream must be within +/- 200 ppm of the local REFCLK..

The maximum bit synchronization time is required under conditions of minimum permissible receiver eye opening & worst-case relative phase difference alignment between the bitstream and the CDR. Under these conditions, the maximum bit sync time is determined by the transition density of the incoming bit stream. Should a difference in DC Common Mode voltages exist, the minimum signal amplitude must be increased by an equivalent amount in order to maintain the shortest possible bit sync time.

An 8B/10B coded bitstreams that contain the idle ordered set of K28.5, D16.2 will provide a nominal transition density of approximately 60%, and will result in a maximum bit synchronization time of 500 bit times. With other transition densities, the bit synchronization time can be calculated as:

$$T_{\text{BitSync}} \text{ (in bit times)} = 24000 / \text{nominal transition density (expressed as a percentage)}$$

This determination of bit sync time is only applicable when the CDRU inputs are switched from one transitioning bitstream to another. Should the inputs remain inactive for several 1000s of bit times, bit synchronization will be delayed while the external AC coupling capacitors at the input of the SERDES charge to their steady state values. In this case, the maximum bit synchronization time is 2000 bit times.

Byte Alignment and Synchronization

The character alignment logic searches the coded incoming serial stream for a sequence defined in *IEEE 802.3-2000* as a comma. A comma is the sequence 0011111 or its complement and is unique in valid 10B coded data. This makes the comma useful for detecting proper alignment of incoming characters to byte boundaries. Upon detection of a comma, the alignment logic shifts the incoming data to align the received data properly in the 10-bit character field. An optional Byte-Sync State machine, shown in Figure 13, is implemented on a per channel basis to enable character alignment and preserve the alignment through occasional bit errors.

If a channel's Byte Synchronization State Machine is in the LOSS_OF_SYNC state, it can acquire synchronization by detecting four code-groups that contain commas without detecting code-group errors. An initial comma must be detected by the character alignment logic before the state machine can start the synchronization process. Once synchronization is acquired, the channel moves into the SYNC_ACQ_1 state. The state machine tests the received code-group to move between the SYNC_ACQ_1 and LOSS_OF_SYNC states. To prevent loss of synchronization during occasional bit errors, hysteresis can be added by setting the BA_HYST_EN bit in PMC Control 3 Register. The Byte Sync State Machine operates independently from the PCS Synchronization State Machine described in PCS Receive Section.

Hysteresis is normally disabled upon reset. In this case, once the channel's synchronization state machine has entered the SYNC_ACQ_1 state, any realignment caused by the detection of a comma in a new location causes the channel to move to the LOSS_OF_SYNC state. If hysteresis is enabled, the synchronization process uses the hysteresis defined in the synchronization state machine. Even if a channel's hysteresis is disabled, the synchronization state machine continues to monitor alignment and supply a synchronization status indication. If a channel's synchronization state machine enters the LOSS_OF_SYNC state, the corresponding BYTE_ALIGN_STAT_[D:A] bit in Auto-Negotiation Status Register 2 latches the low valued status and holds it until a read of that register is preformed.

The serial bit stream must be ordered 'abcdeifghj' with 'a' being the first bit received and 'j' the last bit received. The recovered receive clocks are neither stretched nor slivered during character alignment. During alignment up to, but not exceeding, four 10-bit code groups may be deleted or modified while aligning the code group to the edges of the receive clock.

Figure 13 Byte Synchronization State Machine

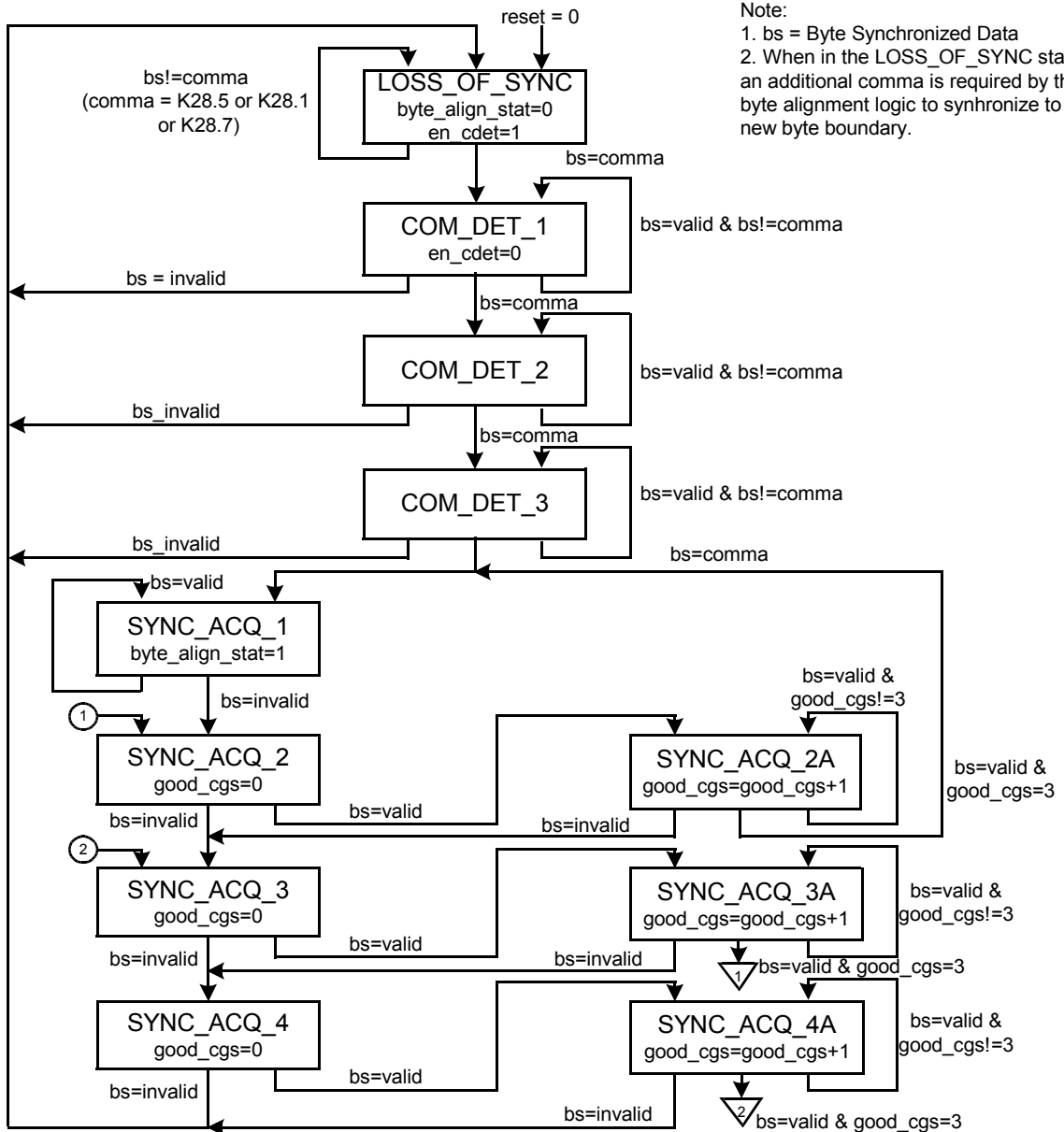

8B/10B Decoder

When enabled, each receive channel decodes incoming data into an 8-bit data byte and an associated control bit called the k-bit. Information is routed and processed internally in this 9-bit parallel form. The decoder monitors for proper disparity and coding logging errors. A 10th bit for indicating a code violation or disparity error is also routed with the 9-bit parallel data. When the CODE_VIOL_DIS_ENABLE (bit 14 PMC Control 2) or the CV_DIS_EN pin is set, errors are reinforced by the receiver by substituting the code, 0x3FF, for the byte in error.

When the EN_CODE_ERR_CHK bit in Register 0x1B is a logic 1, the 8B/10B decoder in the corresponding channel will count coding errors received and will flag the error count reaching the maximum set by PKT_CNT[14:0] in Register 0x1C. The error will be indicated by the CODE_ERR_EXCEED bit in Register 0x1B being read as logic 1. CODE_ERR_EXCEED will hold the error until Register 0x1B is read. The 8B/10B coding error counters in all channels will be cleared whenever the CODE_ERR_STB bit in register 24 is set to logic 1. CODE_ERR_STB is self-clearing.

Receive PCS

The QuadPHY 1G supports the 1000Base-X PCS for full-duplex applications. Note that carrier sense (CRS) and collision detect (COL) are not supported per *IEEE 802.3-2000* standard. The PCS functionality is enabled by setting the PCS_ENABLE bit and the INT_DEC_ENC_ENABLE bit in Register 0x11.

The PCS receive logic contains an 8B/10B decoder, synchronization state machine, receive state machine, and auto-negotiation (AN) state machine. All receive blocks are compliant with the *IEEE 802.3-2000* (Clauses 36 and 37). The AN state machine supports both base page and next page exchange as well as having programmable link timers. The link timer value can be programmed via LINK_TIMER_MODE bits [1:0] of Register 0x11. The link timers can be set to approximately 12.6 ms or 16.8 ms to be compliant with the *IEEE 802.3-2000*, the default is 16.8 ms.

The management interface provides AN registers as prescribed by IEEE 802.3-2000. Additionally, two status registers,

Register 0x19 (Auto Negotiation Status 1) and Register 0x1A (Auto Negotiation Status 2), have been added for polling the four separate ports with a single management register read.

Register 0x19 contains a base page received and a next page received indication for each port. These bits clear on read. Normally during AN, a channel's base page received bit will get set once and then the next page received bit for that channel would get set for any subsequent pages received. If the base page received bit becomes set again during AN, it is an indication that AN has been restarted for that port. Register 0x1A contains an indication for each channel that AN has completed. Both of the status registers reflect same information found in Register 0x01 (Status), bit 5 and Register 0x06 (AN Expansion), bit 1. Reading

Register 0x19 only clears that register; it does not clear the page received bits in Register 0x06. The opposite is also true; when reading Register 0x06,

Register 0x19 is not cleared.

Additional information on PCS and GMII can be found in *IEEE* 802.3 sections 35 and 36.

Receive FIFO

The Receive FIFO transfers data from the recovered clock domain to the internal clock domain that is synchronous to REFCLK. The Receive FIFO compensates for differences in the clock tolerances. The Receive FIFO is used in the LRRC, Trunking, and Parallel Loopback Mode. The Receive FIFO is not used in RRRC and HRRC Mode. In addition, in Trunking Mode, the Receive FIFO is used for channel (lane) alignment, removing skew differences between channels.

The Receive FIFO achieves clock tolerance compensation by inserting or deleting 2 octet wide IDLE sequences as needed. Figure 14 illustrates the insertion (and deletion) of an IDLE sequence when the recovered clock is running slower (or faster) than the REFCLK. The Receive FIFO will only delete an IDLE sequence when more than one IDLE sequences has been recognized. When the Receive FIFO inserts an IDLE sequence, the IDLE sequence inserted is the same as the previous IDLE sequence received.

Figure 14 Insertion/Deletion of Idle Sequences by the Receive FIFO

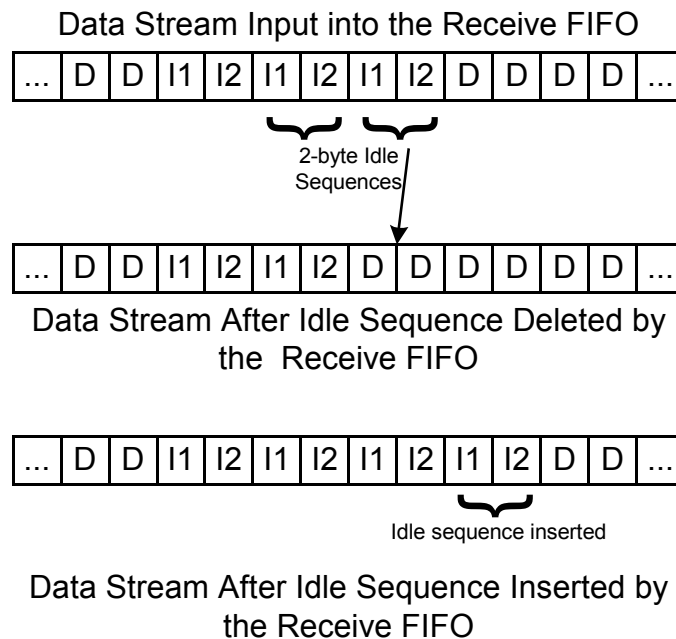

The IDLE sequences are defined by registers 0x12 through 0x15. Registers 0x12 – 0x15 are only used by the Receive FIFO and will not affect the de-serialization process. These registers are formatted as K-bit (bit 8) and data (bits 7:0). Generally, IDLE1 and IDLE1A should be programmed to one of the three valid control characters (K28.1, K28.5, or K28.7) that contain a comma pattern. The decoder must be enabled for the Receive FIFO to use these register values in the clock tolerance compensation logic.

The alternate IDLE sequence registers, IDLE1A and IDLE2A, are available for applications that make use of multiple idle sequences to indicate system conditions. An example of this would be flow control. One IDLE sequence might indicate clear to send while the other sequence indicated not clear to send. If only one IDLE sequence is desired, the two pairs of control registers should be programmed to the same values.

The QuadPHY 1G uses the values stored in the IDLE sequence registers to insert or delete idles in the Receive FIFO. Data can be presented to the QuadPHY 1G with either an IDLE1 or IDLE1A that is not followed by an IDLE2 or IDLE2A. In this condition, the data that follows the IDLE1 or IDLE1A must not be the same as the data stored in the IDLE2 or IDLE2A registers. If the data is the same, the QuadPHY 1G decodes the data pattern that follows the IDLE1 or IDLE1A as a valid IDLE2 or IDLE2A character and could delete it.

Even if the incoming data stream does not contain IDLE sequences, the Receive FIFO can still transfer data from the recovered clock domain to the REFCLK domain and compensate for phase only. The insertion and deletion of IDLE sequences for clock tolerance compensation can be disabled by setting the INS_DEL_DIS bit in PMC Control 3 Register to logic 1.

The depth of the Receive FIFO determines the amount of clock frequency difference the QuadPHY 1G can tolerate. The QuadPHY 1G has a sixteen (16) character deep FIFO on each receive channel. This enables the QuadPHY 1G to tolerate up to ± 200 ppm clock differences on 1600 byte packets with 4 byte IPG. However, larger packet sizes (16K bytes) can be accommodated in systems with tighter clock differences (± 100 ppm) and appropriate IPG (4 bytes).

The typical additional latency due to FIFO operation is six bytes. To accommodate 16K-byte packets with ± 100 ppm reference clock difference between systems, the alignment logic requires that it be able to insert or remove three IDLE sequences between packets. The ability to remove three IDLE sequences gives a safety margin of 2 bytes in system clock differences. Depending on the relative frequency between RBCH_H and the received data frequency, the additional latency due to the FIFO operation could be 2 bytes to 12 bytes. The Receive FIFO depth is programmable via the FIFOCNT[3:0] register, and has a default value of 8. This programmable FIFO depth allows the user to decrease latency if shorter packets or tighter clock tolerances are used.

In Trunking Mode, the Receive FIFO realigns the read pointers to remove channel-to-channel skew differences in addition to performing clock tolerance compensation. Trunking Mode is not functional when the PCS logic is enabled, or when the GEMOD pin or GE_REG bit is set to logic 1. There are two methods of alignment based on the A_CHAR_EN bit in the Trunking Control Register. When A_CHAR_EN is set to logic 1, the Trunking logic within the Receive FIFO looks for an alignment character in each channel being trunked and then realigns all trunked channels' read pointers to the address of the alignment character. The alignment character is defined in the Trunking Control Register. If the INSERT_A_CHAR bit within the Trunking Control Register is set to logic 1, then the Receive FIFO replaces all alignment characters with either an IDLE2 or IDLE2A character depending on the preceding byte being an IDLE1 or IDLE1A, respectively. Figure 15 illustrates Trunking with A_CHAR_EN set to logic 1 and INSERT_A_CHAR set to logic 0.

Figure 15 Trunking Mode Channel Alignment using Alignment Characters

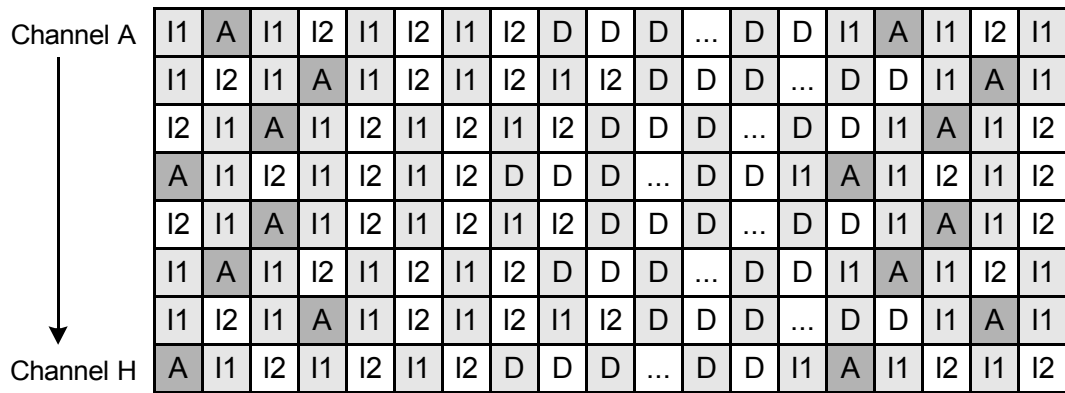

Data Containing Alignment Characters Received with Skew

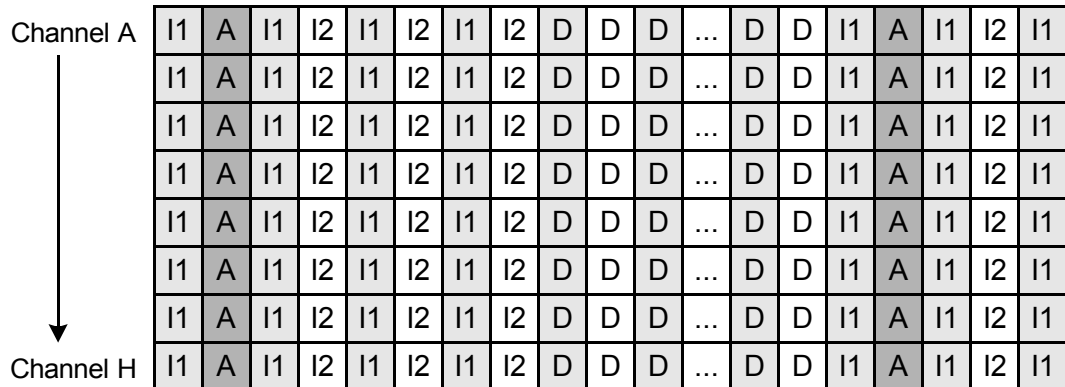

Data Aligned Utilizing Alignment Characters

If the INSERT_A_CHAR bit is set to logic 0 and the A_CHAR_EN bit is set to logic 1, then it is assumed that the alignment character, as defined in the Trunking Control Register, will be present in the Inter Packet Gap periodically inserted into the data stream, across all channels simultaneously.

The alignment character should be present in the received data periodically to induce continuous alignment of all channels. Two or more alignment characters may be present during an IPG, but they must be separated by a distance that is greater than or equal to 16 bytes which is the depth of the receive FIFO.

When A_CHAR_EN is set to logic 0, the Trunking logic within the Receive FIFO looks for a transition from IDLE sequences to data (or non-IDLE sequences). All channels being trunked will realign their read pointers to the transition from IDLE sequence to data simultaneously. Figure 16 illustrates Trunking with A_CHAR_EN set to logic 0.

While operating in the idle-data transition mode, frames should not be sent more often than every 16 columns or 128 bytes (including the IPG). This guarantees that there is enough separation between transitions so that a false realignment will not occur. If packets are required to be sent closer together, it is recommended that the deskew state machines be enabled to reduce the risk of a false channel realignment.

Figure 16 Trunking Mode Channel Alignment using the Transition from Idle to Data

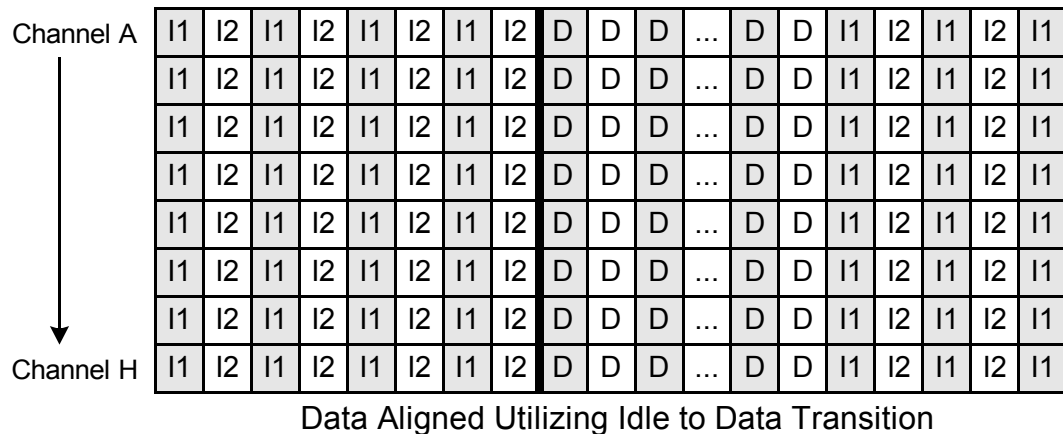
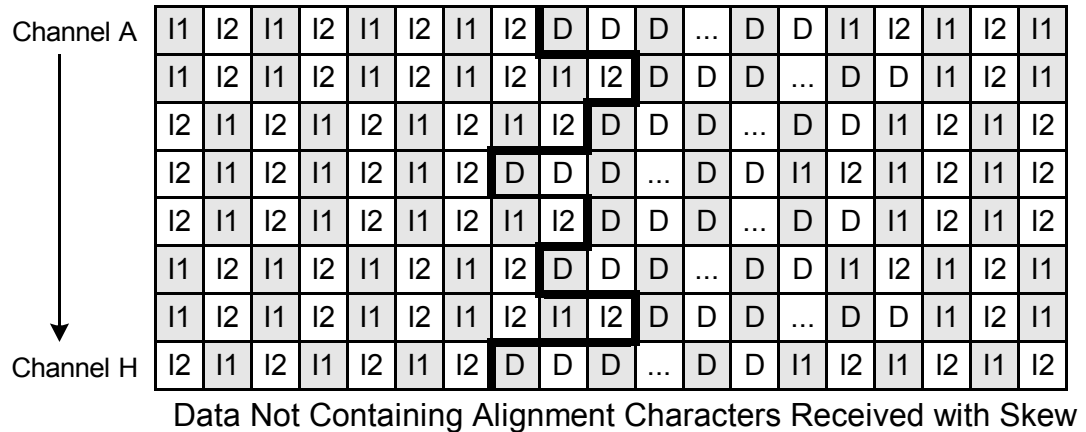

When Trunking, the Receive FIFO performs clock tolerance compensation across all trunked channels simultaneously. All channels must possess valid IDLE sequences for an insertion or deletion of a column of IDLE sequences to occur. Figure 17 illustrates an insertion of a column of IDLE sequences when Trunking. Figure 18 illustrates a deletion of a column of IDLE sequences when Trunking.

The QuadPHY 1G can be used to trunk less than 4 channels at a time, but the unused QuadPHY channels must be disabled. Those channels that are disabled will have no bearing on the alignment or clock tolerance compensation operations.

Figure 17 Insertion of a Column of Idle Sequences when Trunking

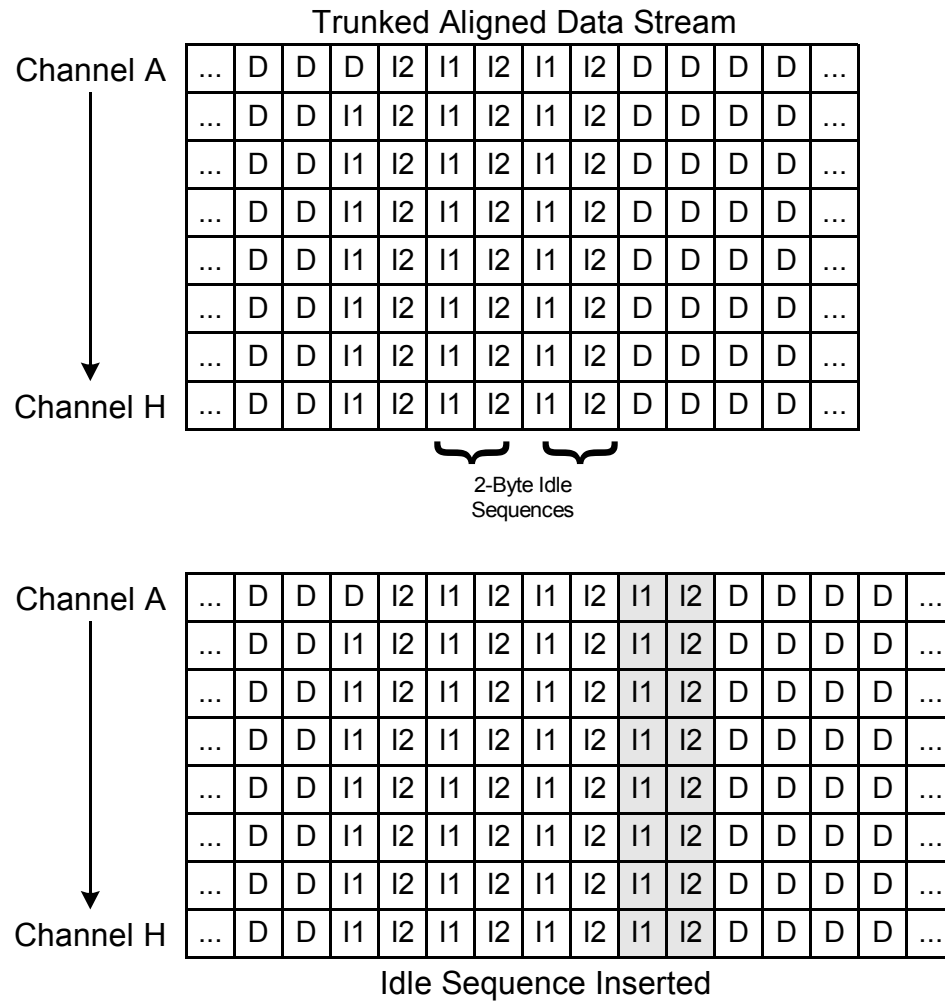
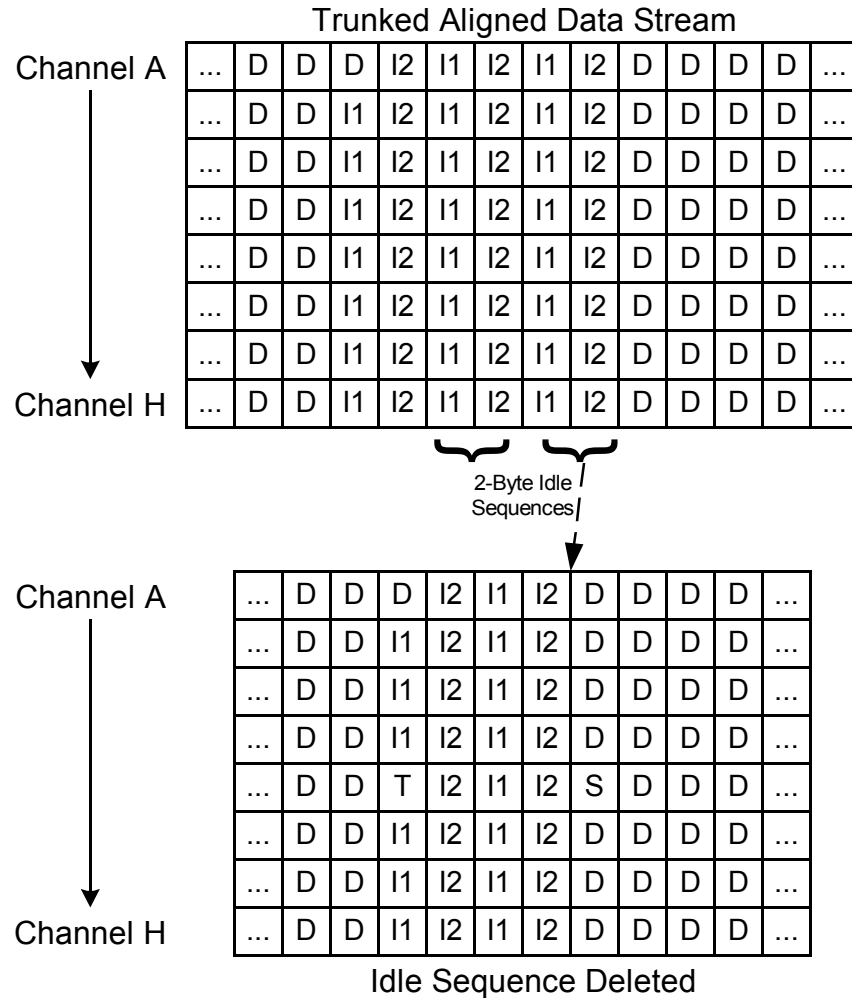

Figure 18 Deletion of a Column of Idle Sequences when Trunking



Maximum Size Packets Supported

Internal logic within the QuadPHY 1G establishes a relationship between the frequency at which serial data is received (f_{DATA}) and ten times the reference clock frequency (f_{REFCLK}) provided by the local clock. This relationship allows the device to recover incoming serial data and place it on the REFCLK domain for further processing. The difference in these two frequencies is usually stated in parts per million (ppm) and is calculated as follows:

$$C_{ppm} = 10^6 \cdot \left| (10 \cdot f_{REFCLK} - f_{DATA}) / (10 \cdot f_{REFCLK}) \right| \tag{1}$$

Clock compensation is the ability for the QuadPHY 1G to adjust for this frequency difference. It uses internal FIFOs to accomplish this.

These same FIFOs are used to eliminate the skew between lanes when in trunking mode. Lane skew is defined as the difference in time between the most delayed lane to the least delayed lane. For convenience, lane skew is measured in bits (b). The absolute delay on any one lane is not relevant in device performance except for its contribution to overall latency.

The size of these internal FIFOs mathematically establish the maximum packet size supported by the device given b and c_{ppm} on a per lane basis. Another factor in determining maximum packet size is whether or not the DESKEW_HYST_EN is enabled (see register 0x18: PMC Control 3). If this register (D) is set to a zero, further maximum packet size degradation occurs.

Equation 2 below is a conservative closed form solution of the largest packet size (S_{max}) supported by the QuadPHY 1G as a function of the number of bits of skew, whether DESKEW_HYST_EN is asserted, the number of lanes (n) being used and the difference is clock frequency in ppm.

$$S_{max} = 10^6 \cdot (5 + D - \text{int}[(b+11)/10]) \cdot n / c_{ppm} \quad (2)$$

As long as the system is operating synchronously (c_{ppm} = 0) and the skew between lanes is less than 40, there is no maximum packet size. Note that for calculations in which the part is not in trunking mode, the skew (b) should be zero and the lanes (n) should be 1. Table 17 gives some examples as to what sorts of maximum packet sizes would be typical of a system.

Table 17 Maximum Packet Size Supported

S _{max} (bytes)	b (bits)	D (unitless)	n (lanes)	c _{ppm} (unitless)
10000	30	0	1	100
20000	35	1	2	200
80000	10	1	4	200
∞	<40	0 or 1	1 – 4	0

10.3.5 Trunking Logic

The trunking logic determines when all lanes being trunked will realign, insert an idle column or delete an idle column when in trunking mode. A two octet wide idle column will be inserted or deleted if all lanes being trunked contain the same idle pattern and at least one lane needs to have an idle inserted or deleted to compensate for the clock rate differences. The trunking logic contains a deskew state machine that monitors the lane to lane word alignment. The deskew state machine determines with hysteresis if all lanes are aligned. The alignment status is reported via the DESKEW_STATUS bit in the Trunking Control register. The deskew state machine is depicted in Figure 19.

Figure 19 Deskew State Machine

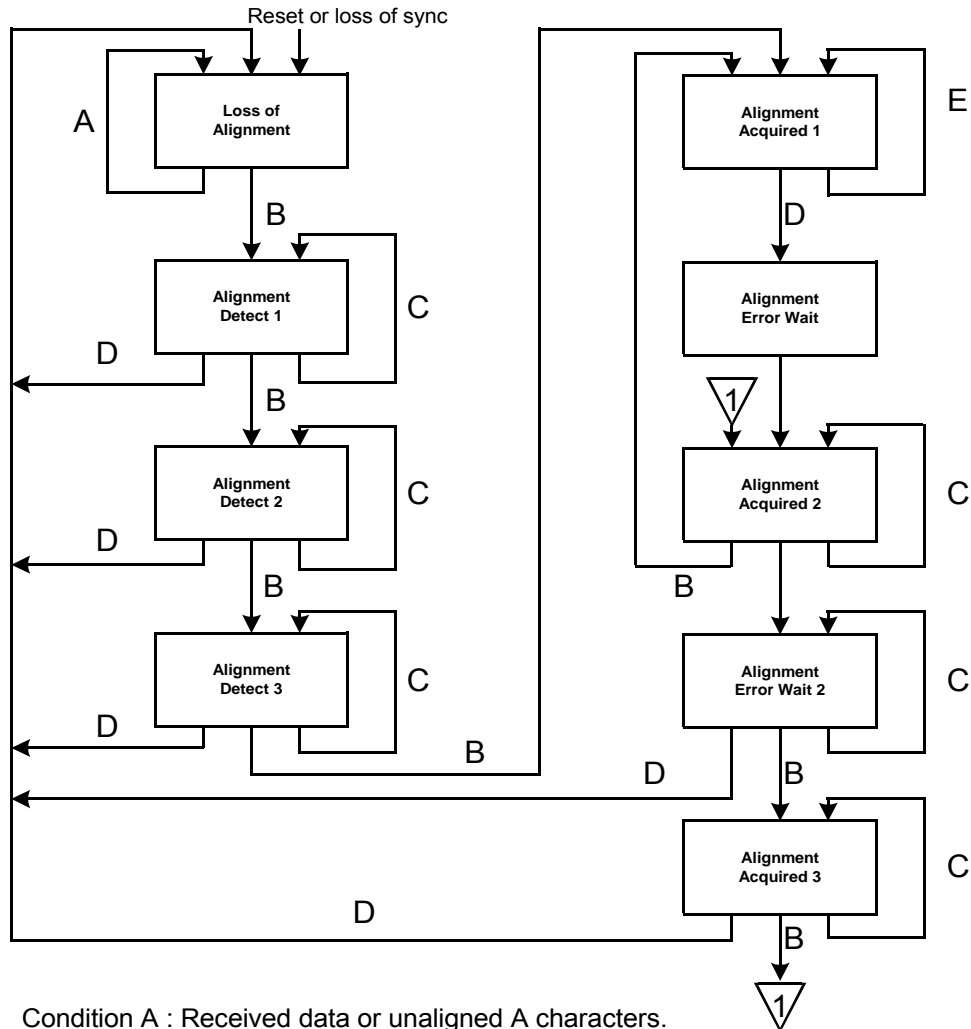

Condition A : Received data or unaligned A characters.
 Condition B: Received correctly aligned A characters.
 Condition C: Received data, not unaligned A characters.
 Condition D: Received unaligned A characters.
 Condition E: Received data or aligned A characters.

All lanes will realign when an alignment character, as defined in the Trunking Control register, is found in each lane's receive FIFO. When DESKEW_HYST_EN in the PMC Control register 3 is a logic 0, realignment will occur whenever there are alignment characters in all receive FIFOs. If all lanes are currently word aligned, a realignment will have no affect on the output data or the receive FIFOs' pointers. When DESKEW_HYST_EN is logic 1, the deskew state machine will control when realignment can occur; realignment will only occur when the deskew state machine is in the Loss of Alignment state.

A subset of the four lanes provided by QuadPHY 1G can be trunked by disabling the undesired channels' ENABLE_CHN_[D:A] bits in PMC Control Register 1.

10.3.6 Gigabit Ethernet and PCS Operating Modes

PCS_ENABLE (bit 2 in Register 0x11h) is used to enable the 1000Base-X PCS logic. The GEMOD pin or the GE_REG register bit is used to enable a small subset of “PCS-type” functions. The description below specifies exact functions which GEMOD/GE_REG affects.

Note that PCS_ENABLE should not be set to logic 1 when either GEMOD or GE_REG register is set to logic 1.

Gigabit Ethernet with PCS Enabled

When the PCS logic is enabled the parallel interface is formatted as GMII data. The PCS logic includes TX and RX state machines, auto-negotiation and byte alignment logic that are fully compliant with the IEEE 802.3 1000Base-X PCS specification.

Gigabit Ethernet with PCS Disabled - GEMOD Enabled and BMOD Disabled

When the GEMOD pin or GE_REG bit in the PMC Control 3 Register is set to logic 1, the parallel interface is formatted as 8B data. The receive FIFO recognizes a decoded /K28.5/ pattern followed by any valid data pattern, /Dx.y/, excluding the /D21.5/ and /D2.2/ data patterns, as an IDLE sequence that can be used for insertion or deletion in clock tolerance compensation. A decoded /K28.5/ pattern followed by the /D21.5/ or /D2.2/ data patterns and then followed by 2 valid data bytes are recognized as a 4-byte configuration pattern as sent during auto-negotiation. These 4-byte configuration patterns can be inserted or deleted for clock tolerance compensation.

Also, in this mode of operation IDLE patterns are corrected to ensure negative running disparity during the IPG by substituting /D5.6/ for /D16.2/ in a /K28.5/Dx.y/ transmit IDLE pair.

Note that Auto-Negotiation functions are NOT performed when GEMOD=1.

Gigabit Ethernet with PCS Disabled - GEMOD Enabled and BMOD Enabled

This mode operates the same as Gigabit Ethernet with PCS Disabled - GEMOD enabled and BMOD disabled shown above. For this mode, when the BMOD pin or the BUSY_REG bit in the PMC Control 3 Register is set to logic 1, a decoded /K28.5/ pattern followed by a /D10.1/ data byte will not be recognized as an IDLE sequence and will not be inserted or deleted.

10.3.7 SDR/DDR Parallel Outputs

The parallel receive interface consists of 40 pins that are divided across 4 channels. Channels A, B, C, and D utilize 10 pins each. Depending on the mode of operation, the pins are configured to operate in either a Single-Data Rate (SDR) fashion, that is, data is output on the rising edge of the receive clock or a Dual-Data Rate (DDR) fashion, that is, data is output on both the rising and falling edge of the receive clock.

In RRRC Mode, the parallel receive pins are configured in SDR mode. The receive clocks are derived from the remote reference clock of each remote transmitter. A full rate receive clock (RBCD1, RBCC1, RBCB1, RBCA1) is used as a reference for each receive data bus. Receive data for channels D, C, B and A are sampled on the rising edge of RBCy1 – see Figure 20.

This mode allows all four channels to operate independently with its own recovered clock and data on a dedicated set of terminals. Frequency differences of ± 200 ppm² of the REFCLK frequency can be tolerated.

Figure 20 Receive Timing for RRRC Mode

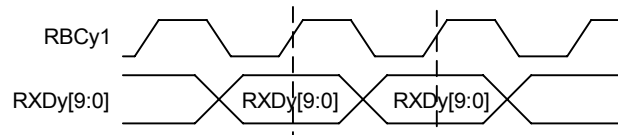

Note:

1. There is no complementary clock (RBCy0) provided in this mode.

In LRRC and Trunking Mode, the parallel receive pins are configured in SDR mode. Receive data for channels D, C, B and A are sampled on the rising edge of RBCD1 (falling edge of RBCD0) see Figure 21. This common complementary receive clock (RBCD1, RBCD0) is used as a reference for received data on all four ports.

Figure 21 Receive Timing for LRRC and Trunking Mode

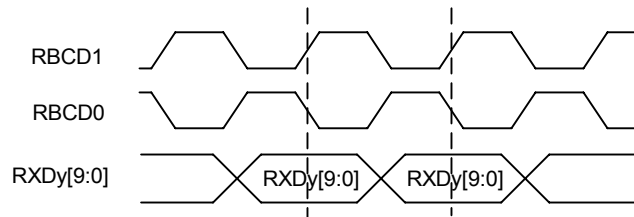

The frequency of the receive data for each channel must be within ± 200 ppm³ of the REFCLK. The receive FIFO on each channel transfers the data from the recovered clock domain to the local clock domain. Idle sequences (2 byte pairs)⁴ are inserted or deleted as needed to compensate for the frequency difference between recovered and local clocks.

² There is no restriction on IPG or packet size in this mode.

³ With 1600 byte packet and 4-byte inter-packet gap (IPG). Adjusting ppm and IPG accommodates larger packet sizes.

⁴ An IDLE sequence is defined as any of the following combinations: IDLE1/IDLE2 or IDLE1A/IDLE2A. These values can be programmed in registers 18-21.

If the frequency of the recovered clock is the same as the local clock (i.e., a synchronous system), the insert/delete function of the receive FIFO can be disabled. In this case both the local receiver and the remote transmitter must use a common clock reference. This is useful when idle insertion and deletion is undesirable.

In HRRC Mode, the parallel receive pins are configured in DDR mode. The receive clocks are derived from the remote reference clock of each remote transmitter. A half rate complementary receive clock pair (RBCD1/RBCD0, RBCC1/RBCC0, RBCB1/RBCB0, RBCA1/RBCA0) is used as a reference for each receive data port. Receive data for channels D, C, B and A are sampled on both edges of RBCy1/RBCy0 – see Figure 22.

This mode allows all four channels to operate independently with its own recovered clock and data on a dedicated set of terminals. Frequency differences of ± 200 ppm⁵ of the REFCLK frequency can be tolerated.

Figure 22 Receive Timing for HRRC Mode

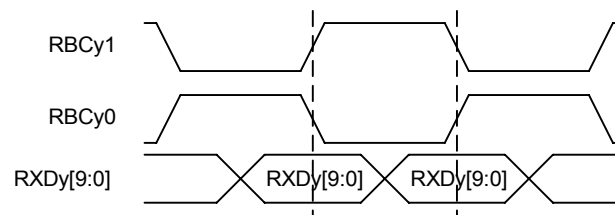

The receive data can be 10B encoded data when the decoder is disabled, 8B data plus K-bit control and code violation/disparity error indication bits when the decoder is enabled, or 8 bits of data (RXD) plus RX_DV and RX_ER (GMII data). Table 18 describes the mapping of data bits per to the receive data ports. When the decoder is disabled, the 10B word is mapped to a TBI (Ten-Bit Interface) and is generally described by “abcdeifghj” where “a” is the least significant bit and deserialized from the wire first and “j” is the most significant bit. When the decoder is enabled, the 8B word is represented by “HGFEDCBA” where “H” is the most significant bit and “A” is the least significant bit, the control value is “K”, and the code violation/disparity error is “CV”. When the PCS logic is enabled, the receive data is mapped to GMII signals.

⁵ There is no restriction on IPG or packet size in this mode.

Table 18 Parallel Receive Interface Pin Mapping

	10B Receive Data	8B Receive Data	GMII DATA
RxDy9	J	CV	RX_ER
RxDy8	H	K	RX_DV
RxDy7	G	H	RXD7
RxDy6	F	G	RXD6
RxDy5	I	F	RXD5
RxDy4	E	E	RXD4
RxDy3	D	D	RXD3
RxDy2	C	C	RXD2
RxDy1	B	B	RXD1
RxDy0	A	A	RXD0

10.4 JTAG Test Access Port

The QuadPHY 1G supports the IEEE Boundary Scan Specification as described in the IEEE 1149.1 standards. The JTAG Test Access Port (TAP) consists of the five standard pins, TRSTB, TCK, TMS, TDI and TDO used to control the TAP controller and the boundary scan registers. The TRSTB input is the active-low reset signal used to reset the TAP controller. TCK is the test clock used to sample data on input, TDI and to output data on output, TDO. The TMS input is used to direct the TAP controller through its states. The basic boundary scan architecture is shown below.

Figure 23 Boundary Scan Architecture

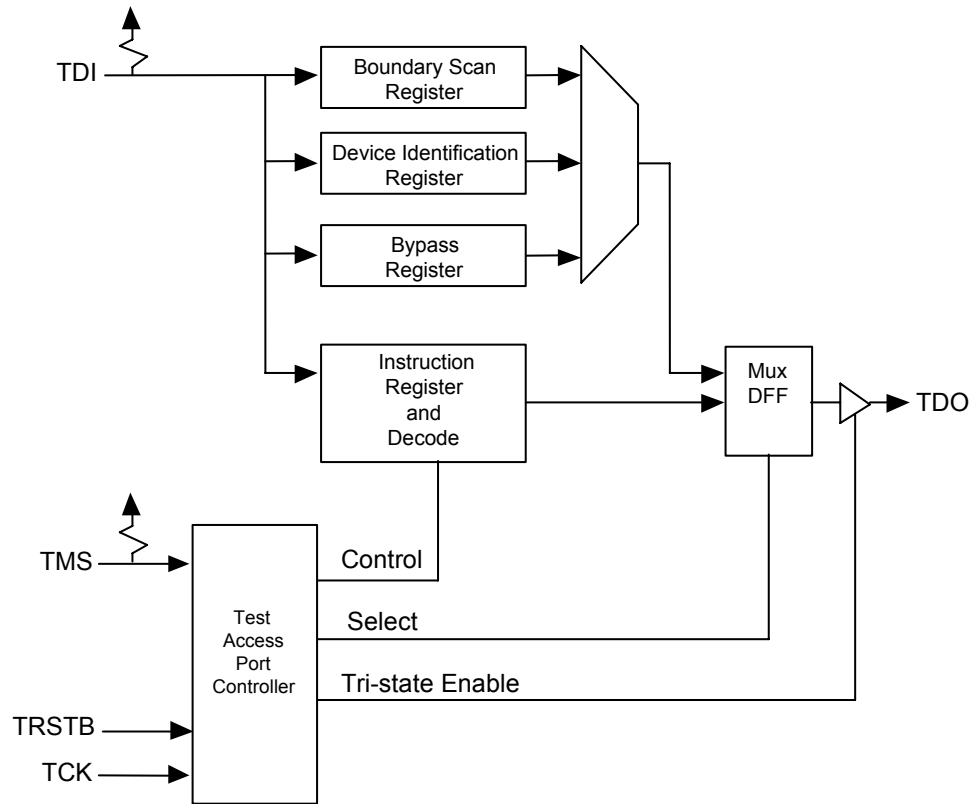

The boundary scan architecture consists of a TAP controller, an instruction register with instruction decode, a bypass register, a device identification register and a boundary scan register. The TAP controller interprets the TMS input and generates control signals to load the instruction and data registers. The instruction register with instruction decode block is used to select the test to be executed and/or the register to be accessed. The bypass register offers a single-bit delay from primary input, TDI to primary output, TDO. The device identification register contains the device identification code.

The boundary scan register allows testing of board inter-connectivity. The boundary scan register consists of a shift register placed in series with device inputs and outputs. Using the boundary scan register, all digital inputs can be sampled and shifted out on primary output, TDO. In addition, patterns can be shifted in on primary input, TDI and forced onto all digital outputs.

10.4.1 TAP Controller

The TAP controller is a synchronous finite state machine clocked by the rising edge of primary input, TCK. All state transitions are controlled using primary input, TMS. The finite state machine is shown in Figure 24.

Figure 24 TAP Controller Finite State Machine

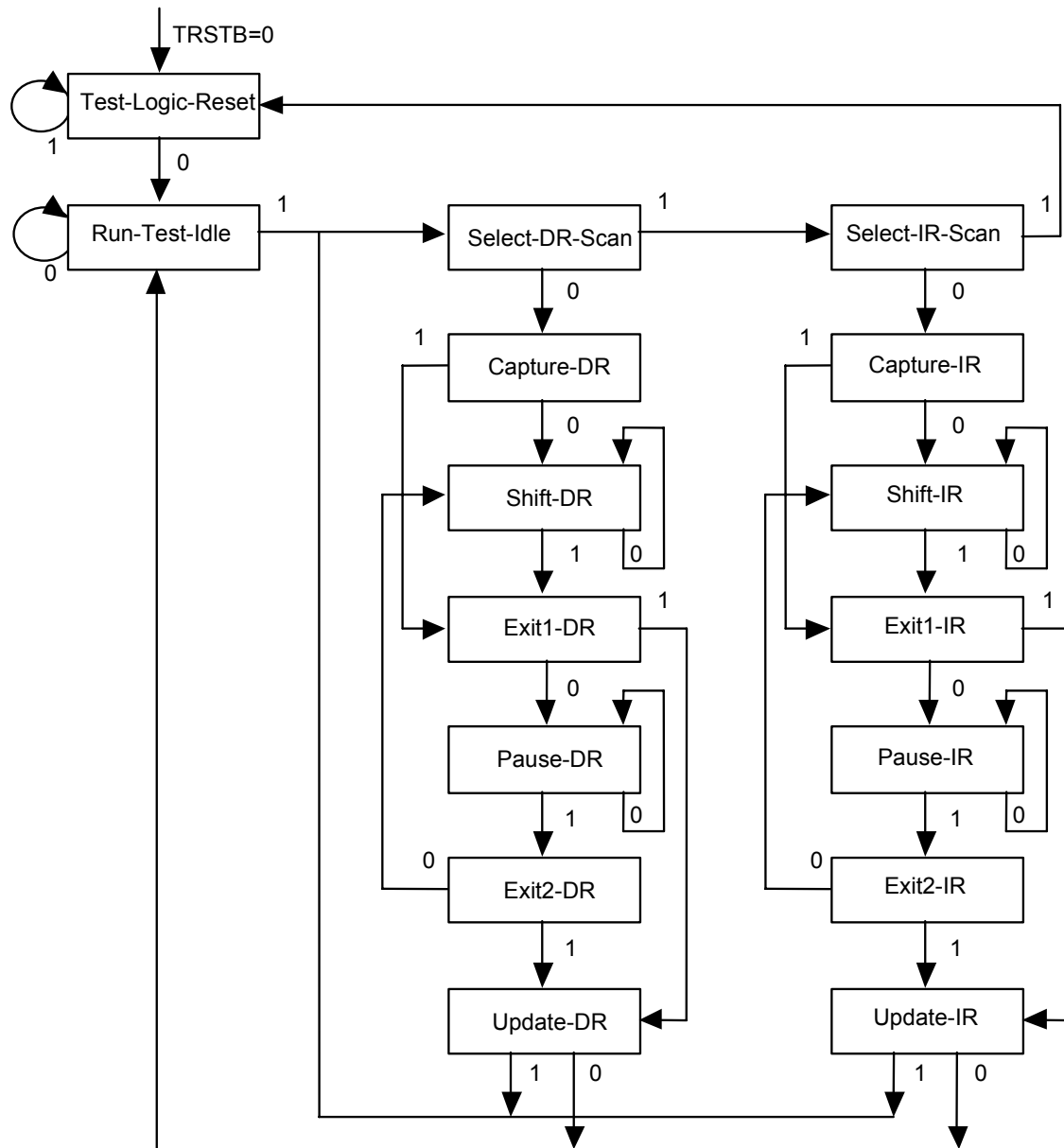

Note:

1. TRSTB must be set to a logic 1 in order to transition out of the Test-Logic-Reset State.
2. The value shown adjacent to each state transition in Figure 24 represents the signal present at TMS at the rising edge of TCK.
3. All transitions are dependent on the logic level of TMS.

Test-Logic-Reset

The test logic reset state is used to disable the TAP logic when the device is in normal mode operation. The state is entered asynchronously by asserting input, TRSTB. The state is entered synchronously regardless of the current TAP controller state by forcing input, TMS high for 5 TCK clock cycles. While in this state, the instruction register is set to the IDCODE instruction.

Run-Test-Idle

The run test/idle state is used to execute tests.

Capture-DR

The capture data register state is used to load parallel data into the test data registers selected by the current instruction. If the selected register does not allow parallel loads or no loading is required by the current instruction, the test register maintains its value. Loading occurs on the rising edge of TCK.

Shift-DR

The shift data register state is used to shift the selected test data registers by one stage. Shifting is from MSB to LSB and occurs on the rising edge of TCK.

Update-DR

The update data register state is used to load a test register's parallel output latch. In general, the output latches are used to control the device. For example, for the EXTEST instruction, the boundary scan test register's parallel output latches are used to control the device's outputs. The parallel output latches are updated on the falling edge of TCK.

Capture-IR

The capture instruction register state is used to load the instruction register with a fixed instruction. The load occurs on the rising edge of TCK.

Shift-IR

The shift instruction register state is used to shift both the instruction register and the selected test data registers by one stage. Shifting is from MSB to LSB and occurs on the rising edge of TCK.

Update-IR

The update instruction register state is used to load a new instruction into the instruction register. The new instruction must be scanned in using the Shift-IR state. The load occurs on the falling edge of TCK.

The Pause-DR and Pause-IR states are provided to allow shifting through the test data and/or instruction registers to be momentarily paused.

10.4.2 Boundary Scan Instructions

The following is a description of the standard instructions. Each instruction selects a serial test data register path between input, TDI and output, TDO.

BYPASS

The bypass instruction shifts data from input, TDI to output, TDO with one TCK clock period delay. The instruction is used to bypass the device.

EXTEST

The external test instruction allows testing of the interconnection to other devices. When the current instruction is the EXTEST instruction, the boundary scan register is placed between input, TDI and output, TDO. Primary device inputs can be sampled by loading the boundary scan register using the Capture-DR state. The sampled values can then be viewed by shifting the boundary scan register using the Shift-DR state. Primary device outputs can be controlled by loading patterns shifted in through input TDI into the boundary scan register using the Update-DR state.

SAMPLE

The sample instruction samples all the device inputs and outputs. For this instruction, the boundary scan register is placed between TDI and TDO. Primary device inputs and outputs can be sampled by loading the boundary scan register using the Capture-DR state. The sampled values can then be viewed by shifting the boundary scan register using the Shift-DR state.

IDCODE

The identification instruction is used to connect the identification register between TDI and TDO. The device's identification code can then be shifted out using the Shift-DR state. The QuadPHY 1G identification code has not been assigned at this time.

STCTEST

The single transport chain instruction is used to test out the TAP controller and the boundary scan register during production test. When this instruction is the current instruction, the boundary scan register is connected between TDI and TDO. During the Capture-DR state, the device identification code is loaded into the boundary scan register. The code can then be shifted out output, TDO using the Shift-DR state

10.5 Microprocessor Interface

The QuadPHY 1G implements a management interface that uses a protocol defined in *IEEE* 802.3. This two-wire interface is used for configuration, control and status of up to eight QuadPHY 1G devices and consists of MDC (management data clock) and MDIO (management data I/O) terminals. This interface allows serial read/write of internal control and status registers. The register map is defined in Table 20. Note that there are both global address registers, a single register used for all channels and addressed only by bits PHYAD[4:2] of the management frame, and per-port addressed registers, a register addressed using all bits of PHYAD of the management frame. Figure 25 illustrates the addressing of both the global and per-port registers.

Figure 25 Register Access

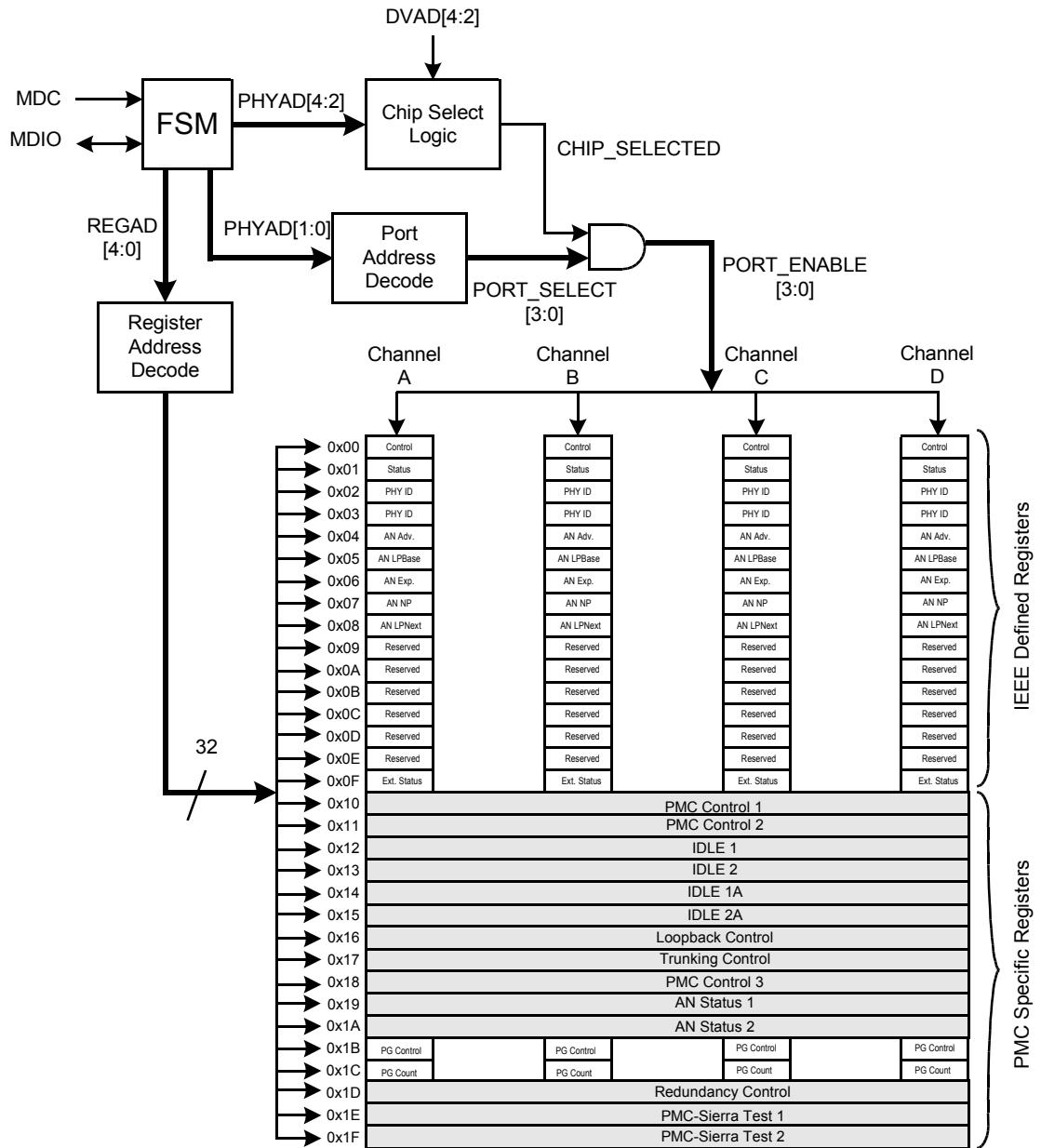

Frames transmitted on the management interface have the frame structure shown in. The order of bit transmission is from left to right.

Table 19 Management Interface Frame Format

	PRE	ST	OP	PHYAD	REGAD	TA	Data	Idle
READ	1 1	01	10	AAAAA	RRRRR	Z0	DDDDDDDDDDDDDDDDDD	Z
WRITE	1 1	01	01	AAAAA	RRRRR	10	DDDDDDDDDDDDDDDDDD	Z

PRE (Preamble) - At the beginning of each transaction, the management interface controller sends a sequence of 32 contiguous logic 1 bits on MDIO with 32 corresponding cycles on MDC to provide the QuadPHY 1G with a pattern that it can use to establish synchronization. The QuadPHY 1G observes a sequence of 32 contiguous 1 bits on MDIO with 32 corresponding cycles on MDC before it responds to any transaction.

ST (Start of Frame) - is indicated by a <01> pattern. This pattern assures transitions from the default logic 1 line state to 0 and back to 1.

OP (Operation Code) - The operation code for a read transaction is <10>, while the operation code for a write transaction is <01>.

PHYAD (PHY Address) - is 5 bits, allowing 32 unique device addresses (i.e., eight QuadPHY 1Gs consisting of four devices each.) The first PHY address bit transmitted and received is the MSB of the address.

The QuadPHY 1G will respond only when the PHYAD[4:2] bits match the DVAD[4:2] terminal values. A given port is addressable by the PHYAD[1:0] bits. Note the DVAD[1:0] terminals are unused and should be tied to ground.

REGAD (Register Address) – is 5 bits, allowing 32 individual registers to be addressed within each QuadPHY 1G. The first Register Address bit transmitted and received is the MSB of the address.

TA (Turnaround) – is a 2-bit time spacing between the Register Address field and the Data field of a management frame to avoid contention during a read transaction. For a read transaction, both the management interface controller and the QuadPHY 1G remain in a high-impedance state for the first bit time of the turnaround. The QuadPHY 1G drives a 0 bit during the second bit time of the turnaround of a read transaction. During a write transaction, the management interface controller drives a 1 bit for the first bit time of the turnaround and a 0 bit for the second bit time of the turnaround.

Figure 26 Behavior of MDIO During TA Field of a Read Transaction

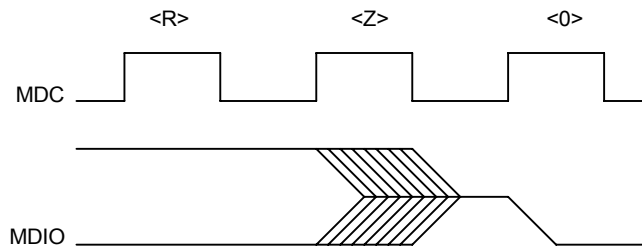

DATA - 16-bit field. The first data bit transmitted and received is bit 15 (MSB) of the register being addressed.

IDLE – logic state on MDIO is high-impedance. MDIO must be pulled high when not driven.

Table 20 Register Memory Map

Address (Hex)	Register
0x00	GMII Control
0x01	GMII Status
0x02	GMII PHY Identifier
0x03	GMII PHY Identifier
0x04	GMII Auto-Negotiation Advertisement
0x05	GMII Auto-Negotiation Link Partner Base Page Ability
0x06	GMII Auto-Negotiation Expansion
0x07	GMII Auto-Negotiation Next Page Transmit
0x08	GMII Auto-Negotiation Link Partner Next Page Received
0x09	GMII Reserved
0x0A	GMII Reserved
0x0B	GMII Reserved
0x0C	GMII Reserved
0x0D	GMII Reserved
0x0E	GMII Reserved
0x0F	GMII Extended Status
0x10	PMC Control 1
0x11	PMC Control 2
0x12	IDLE 1
0x13	IDLE 2
0x14	IDLE 1A
0x15	IDLE 2A
0x16	Loopback Control

Address (Hex)	Register
0x17	Trunking Control
0x18	PMC Control 3
0x19	Auto-Negotiation Status 1
0x1A	Auto-Negotiation Status 2
0x1B	Packet Generator/Checker Control/Status
0x1C	Packet Generator Count Control
0x1D	Redundancy Control Register
0x1E	Reserved/PMC Test 1
0x1F	Reserved/PMC Test 2

Note:

1. Registers 0x00 – 0x0F are only valid when PCS_ENABLE = 1.
2. Registers 0x1B and 0x1C are only valid when PCS_ENBABLE = 0.

11 Normal Mode Register Description

Normal mode registers are used to configure and monitor the operation of the QuadPHY 1G.

Notes on Normal Mode Register Bits:

1. Writing values into unused register bits has no effect. However, to ensure software compatibility with future, feature-enhanced versions of the product, unused register bits must be written with logic 0. Reading back unused bits can produce either a logic 1 or a logic 0; hence, unused register bits should be masked off by software when read
2. In configuration bits that can be written into can also be read back. This allows the processor controlling the QuadPHY 1G to determine the programming state of the block
3. Writeable normal mode register bits are cleared to logic 0 upon reset unless otherwise noted
4. Writing into read-only normal mode register bit locations does not affect QuadPHY 1G operation unless otherwise noted
5. Certain register bits are reserved. These bits are associated with either reserved addresses dictated by the IEEE 802.3 standard or PMC-Sierra Test functions. To ensure that the QuadPHY 1G operates as intended, reserved register bits must be written with their default value as indicated by the register bit description

11.1 IEEE Defined Registers

Register 0x00: GMII Control

Bit	Type	Function	Default
Bit 15	R/W ¹	RESET	0
Bit 14	R/W	LOOPBACK	0
Bit 13	R	SPEED_SELECTION_LSB	0
Bit 12	R/W	AN_ENABLE	1
Bit 11	R/W	POWER_DOWN	0
Bit 10	R/W	ISOLATE	0
Bit 9	R/W ¹	RESTART_AN	0
Bit 8	R	DUPLEX_MODE	1
Bit 7	R	COLLISION_TEST	0
Bit 6	R	SPEED_SELECTION_MSB	1
Bit 5	R	RESERVED	0
Bit 4	R	RESERVED	0
Bit 3	R	RESERVED	0
Bit 2	R	RESERVED	0
Bit 1	R	RESERVED	0
Bit 0	R	RESERVED	0

Note:

1. When written with a 1, this bit self clears.

The GMII Control Register provides control over the basic functionality of the QuadPHY 1G. For additional information refer to *IEEE* Standard 802.3, Section 22.2.4.1.

SPEED_SELECTION_MSB

The SPEED_SELECTION_MSB bit is used in conjunction with the SPEED_SELECTION_LSB bit (bit 13) to select the speed of operation. Since the QuadPHY 1G only supports 1000Mbps operation, the SPEED_SELECTION_MSB is a read only bit that is always set to a logic 1.

COLLISION_TEST

The Collision Test functions is not supported by the QuadPHY 1G. Therefore, the COLLISION_TEST bit is a read only bit that is always set to zero.

DUPLEX_MODE

The QuadPHY 1G operates in full-duplex mode. Therefore, the DUPLEX_MODE bit is a read only bit that is always set to a logic 1.

RESTART_AN

If a PHY reports via the AN_ENABLE bit (bit 12), that it lacks the ability to perform Auto-Negotiation, or if Auto-Negotiation is disabled, the QuadPHY 1G will return a value of zero for the RESTART_AN bit. If this is the case, the RESTART_AN bit should be written as zero and any attempt to write a logic 1 will be ignored.

Otherwise, the Auto-Negotiation process is started by setting the RESTART_AN to a logic 1. This bit is self-clearing, and the RESTART_AN bit will return a logic 1 until the Auto-Negotiation process has been initiated. The Auto-Negotiation process is not affected by writing a logic 0 into bit RESTART_AN bit.

ISOLATE

The ISOLATE bit is initialized to a logic 0 for normal operation. If the ISOLATE bit is set to a logic 1 and the QuadPHY 1G's PCS Logic is enabled, the associated transmit and receive channel data paths will be disabled and will be isolated from the GMII. If the QuadPHY 1G's PCS Logic is disabled, the state of the ISOLATE bit has no effect on the channel's operation.

POWER_DOWN

The associated channel on the QuadPHY 1G is placed in a low-power consumption state by setting the POWER_DOWN bit to a logic 1. Clearing the POWER_DOWN bit to a logic 0 allows for normal operation. The QuadPHY 1G's PCS Logic must be enabled to allow the POWER_DOWN bit to operate as specified. If the PCS Logic is disabled, the state of the POWER_DOWN bit has no effect on the channel's operation. While in the power-down state, the QuadPHY 1G responds to management transitions.

AN_ENABLE

The Auto-Negotiation process is enabled by setting the AN_ENABLE bit to a logic 1. If the AN_ENABLE bit is enabled, the Speed Select and Duplex Mode bits have no effect on the link configuration other than providing status. If the AN_ENABLE bit is cleared to a logic 0 then the Speed Select and Duplex Mode bits determine the link configuration.

SPEED_SELECTION_LSB

The SPEED_SELECTION_LSB bit is used in conjunction with the SPEED_SELECTION_MSB bit (bit 6) to select the speed of operation. Since the QuadPHY 1G supports only 1000Mbps operation, the SPEED_SELECTION_LSB is a read-only bit that is always set to a logic 0.

LOOPBACK

The QuadPHY 1G is placed into High-speed Serial Loopback Mode when the LOOPBACK bit is set to a logic 1. When the LOOPBACK bit is set, the QuadPHY 1G accepts data from the GMII transmit data path and returns it to the GMII receive data path. Clearing the LOOPBACK bit to a logic 0 allows the QuadPHY 1G to operate normally. The DIGITAL_LOOPBACK_EN Control Bit (Bit 7 of Register 0x18) must be set to a logic 0 to operate this Serial Loopback Mode.

RESET

Setting this bit to a logic 1 resets the associated channel in the QuadPHY 1G. This action sets the status and control registers to their default states. As a consequence, this action can change the internal state of the QuadPHY 1G and the state of the physical link associated with the QuadPHY 1G. This bit is self-clearing and the QuadPHY 1G will return a value of one in bit 15 until the reset process is complete. The QuadPHY 1G is not required to accept a write transaction to the control register until the reset process is complete. Writing to bits of the control register other than bit 15 will have no effect until the reset process is completed.

Register 0x01: GMII Status

Bit	Type	Function	Default
Bit 15	R	100BASE-T4	0
Bit 14	R	100BASE-X_FULL_DUPLEX	0
Bit 13	R	100BASE-X_HALF_DUPLEX	0
Bit 12	R	10MBS_FULL_DUPLEX	0
Bit 11	R	10MBS_HALF_DUPLEX	0
Bit 10	R	100BASE-T2_FULL_DUPLEX	0
Bit 9	R	100BASE-T2_HALF_DUPLEX	0
Bit 8	R	EXTENDED_STATUS	1
Bit 7	R	RESERVED	0
Bit 6	R	MF_PREAMBLE_SUPPRESSION	1
Bit 5	R	AN_COMPLETE	0
Bit 4	R ¹	REMOTE_FAULT	0
Bit 3	R	AN_ABILITY	1
Bit 2	R ²	LINK_STATUS	0
Bit 1	R	JABBER_DETECT	0
Bit 0	R	EXTENDED_CAPABILITY	1

Notes:

1. This bit latches high and is cleared when read
2. This bit latches low and is set when read

The GMII Status Register provides status over the basic functionality of the QuadPHY 1G. All of the bits in the Status Register are read only, a write to this register has no effect. For additional information refer to *IEEE* Standard 802.3, Section 22.2.4.2.

EXTENDED_CAPABILITY

The EXTENDED_CAPABILITY bit is set to a logic 1 which indicates that the QuadPHY 1G provides an extended set of capabilities that can be accessed through the extended register set.

JABBER_DETECT

The QuadPHY 1G is specified to operate at 1000Mb/s. PHYs specified to operate at this speed do not incorporate the Jabber Detect function, as this function is defined to be preformed in the repeater unit at this speed. Therefore, the QuadPHY 1G always returns a value of zero for JABBER_DETECT.

LINK_STATUS

When the LINK_STATUS bit is read as a logic 1, it indicates that the QuadPHY 1G has determined that a valid link has been established. When read as a logic 0, it indicates that the link is not valid. The LINK_STATUS bit is implemented with a latching function, such that the occurrence of a link failure will cause the LINK_STATUS bit to be cleared and remain cleared until the GMII Status Register is read.

AN_ABILITY

The QuadPHY 1G has the ability to perform Auto-Negotiation. Therefore, the AN_ABILITY bit will return a logic 1 when read.

REMOTE_FAULT

When the REMOTE_FAULT bit is read as a logic 1, it indicates that a remote fault condition has been detected. The REMOTE_FAULT bit is implemented with a latching function, such that the occurrence of a remote fault will cause the REMOTE_FAULT bit to be set and remain set until the GMII Register is read or when the QuadPHY 1G is reset.

AN_COMPLETE

When the AN_COMPLETE bit is read as a logic 1, it indicates that the Auto-Negotiation process has been completed, and that the contents of the extended registers implemented by the Auto-Negotiation protocol are valid. The QuadPHY 1G returns value of zero in the AN_COMPLETE bit if Auto-Negotiation is disabled.

MF_PREAMBLE_SUPPRESSION

The QuadPHY 1G is capable of accepting management frames regardless of whether they are or are not preceded by the preamble pattern described in the IEEE Standard 802.3, Section 22.2.4.4.2. Therefore, the MF_PREAMBLE_SUPPRESSION bit returns a logic 1 when read.

EXTENDED_STATUS

The QuadPHY 1G provides extended base register status information in GMII register 0x0F. Therefore, this bit returns a logic 1 when read.

100BASE-T2_HALF_DUPLEX

The QuadPHY 1G does not support half duplex link transmission and reception using the 100BASE-T2 signaling specification. Therefore, this bit returns a logic 0 when read.

100BASE-T2_FULL_DUPLEX

The QuadPHY 1G does not support full duplex link transmission and reception using the 100BASE-T2 signaling specification. Therefore, this bit returns a logic 0 when read.

10MBS_HALF_DUPLEX

The QuadPHY 1G does not support half duplex link transmission and reception while operating at 10 Mb/s. Therefore, this bit returns a logic 0 when read.

10MBS_FULL_DUPLEX

The QuadPHY 1G does not support full duplex link transmission and reception while operating at 10 Mb/s. Therefore, this bit returns a logic 0 when read.

100BASE-X_HALF_DUPLEX

The QuadPHY 1G does not support half duplex link transmission and reception using the 100BASE-X signaling specification. Therefore, this bit returns a logic 0 when read.

100BASE-X_FULL_DUPLEX

The QuadPHY 1G does not support full duplex link transmission and reception using the 100BASE-X signaling specification. Therefore, this bit returns a logic 0 when read.

100BASE-T4

The QuadPHY 1G does not support link transmission and reception using the 100BASE-T4 signaling specification. Therefore, this bit returns a logic 0 when read.

Register 0x02: GMII PHY Identifier 1

Bit	Type	Function	Default
Bit 15	R	PHY_ID_1[15]	0
Bit 14	R	PHY_ID_1[14]	0
Bit 13	R	PHY_ID_1[13]	0
Bit 12	R	PHY_ID_1[12]	0
Bit 11	R	PHY_ID_1[11]	0
Bit 10	R	PHY_ID_1[10]	0
Bit 9	R	PHY_ID_1[9]	0
Bit 8	R	PHY_ID_1[8]	0
Bit 7	R	PHY_ID_1[7]	0
Bit 6	R	PHY_ID_1[6]	0
Bit 5	R	PHY_ID_1[5]	0
Bit 4	R	PHY_ID_1[4]	1
Bit 3	R	PHY_ID_1[3]	1
Bit 2	R	PHY_ID_1[2]	1
Bit 1	R	PHY_ID_1[1]	0
Bit 0	R	PHY_ID_1[0]	0

The GMII PHY Identifier 1 register contains bit 3 through 18 of the Organizationally Unique Identifier (OUI) assigned to PMC-Sierra by the IEEE. This PHY Identifier is intended to provide sufficient information to support the ResourceTypeID object as required in *IEEE* Standard 802.3, Section 30.1.2.

PHY_ID_1[15:0]

The PHY_ID_1 bits contain bits 3 through 18 of the Organizationally Unique Identifier (OUI). The 3rd bit of the OUI is assigned to PHY_ID_1[15], the 4th bit of the OUI is assigned to PHY_ID_1[14], and so on. Bit PHY_ID_1[0] contains the 18th bit of the OUI. The default setting for PHY_ID_1[15:0] is 0x001Ch.

The Organizationally Unique Identifier (OUI) field is a 24-bit field that extends across the two GMII PHY Identifier Registers. Its value is 00E004H. The mapping of the OUI to the PHY Identifier registers is described below.

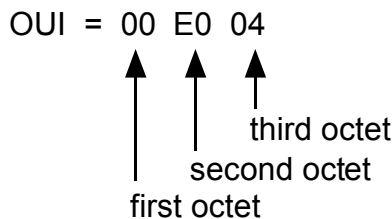

Register 0x03: GMII PHY Identifier 2

Bit	Type	Function	Default
Bit 15	R	PHY_ID_2[15]	1
Bit 14	R	PHY_ID_2[14]	0
Bit 13	R	PHY_ID_2[13]	0
Bit 12	R	PHY_ID_2[12]	0
Bit 11	R	PHY_ID_2[11]	0
Bit 10	R	PHY_ID_2[10]	0
Bit 9	R	PHY_ID_2[9]	0
Bit 8	R	PHY_ID_2[8]	0
Bit 7	R	PHY_ID_2[7]	0
Bit 6	R	PHY_ID_2[6]	1
Bit 5	R	PHY_ID_2[5]	0
Bit 4	R	PHY_ID_2[4]	1
Bit 3	R	PHY_ID_2[3]	0
Bit 2	R	PHY_ID_2[2]	0
Bit 1	R	PHY_ID_2[1]	0
Bit 0	R	PHY_ID_2[0]	0

The GMII PHY Identifier 2 register contains the 19th through 24th bits of the Organizationally Unique Identifier (OUI) assigned to PMC-Sierra by the IEEE, the 6 bit Manufacturing Model Number and the 4 bit Revision Number. The default value for the GMII PHY Identifier 2 register is 0x8050.

PHY_ID_2[3:0]

PHY_ID_2[3:0] contain the 4 bit Revision Number of the QuadPHY 1G. The default setting for these bits change with device revision. The revision number for Revision A of the QuadPHY 1G is 0x00.

PHY_ID_2[9:4]

PHY_ID_2[9:4] contain the 6 bit Manufacturing Model Number. The default setting for these bits is 0x05.

PHY_ID_2[15:10]

PHY_ID_2[15:10] contain the 19th through 24th bits of the Organizationally Unique Identifier (OUI). The default setting for these bits is 0x20.

Register 0x04: GMII Auto-Negotiation Advertisement

Bit	Type	Function	Default
Bit 15	R/W	NEXT_PAGE	0
Bit 14	R	RESERVED	0
Bit 13	R/W	REMOTE_FAULT[1]	0
Bit 12	R/W	REMOTE_FAULT[0]	0
Bit 11	R	RESERVED	0
Bit 10	R	RESERVED	0
Bit 9	R	RESERVED	0
Bit 8	R/W	PAUSE[1]	0
Bit 7	R/W	PAUSE[0]	0
Bit 6	R/W	HALF_DUPLEX	0
Bit 5	R/W	FULL_DUPLEX	1
Bit 4	R	RESERVED	0
Bit 3	R	RESERVED	0
Bit 2	R	RESERVED	0
Bit 1	R	RESERVED	0
Bit 0	R	RESERVED	0

The GMII Auto-Negotiation Advertisement register contains the advertised ability of the QuadPHY 1G. Before Auto-Negotiation starts, this register is configured to advertise the abilities of the QuadPHY 1G.

FULL_DUPLEX

The QuadPHY 1G is capable of full-duplex operation. This bit is set to a logic 1 for normal operation

HALF_DUPLEX

The QuadPHY 1G supports only full-duplex operation. This bit should be set to a logic 0 for normal operation.

PAUSE[1:0]

PAUSE Capabilities. The QuadPHY 1G device's PAUSE capability is encoded in bits 8:7, and the decodes are shown in the Pause Encoding Table below.

[7]	[8]	Capability
0	0	No PAUSE
0	1	Asymmetric PAUSE toward link partner
1	0	Symmetric PAUSE
1	1	Both Symmetric PAUSE and Asymmetric PAUSE toward local device

REMOTE_FAULT[1:0]

The QuadPHY 1G device's remote fault condition is encoded in bits 13:12 of the base page. Values are shown in Remote Fault Encoding Table shown below. The default value is 0x00b. The QuadPHY 1G indicates a fault by setting a non-zero Remote Fault encoding and re-negotiating.

[12]	[13]	Description
0	0	No error, link OK
0	1	Offline
1	0	Link Failure
1	1	Auto-Negotiation Error

NEXT_PAGE

The base page and subsequent next pages can set the NEXT_PAGE bit to a logic 1 to request next page transmission. Subsequent next pages can set the NEXT_PAGE bit to a logic 0 in order to communicate that there is no more next page information to be sent.

Register 0x05: GMII Auto-Negotiation Link Partner Ability Base Page

Bit	Type	Function	Default
Bit 15	R	NEXT_PAGE	0
Bit 14	R	ACKNOWLEDGE	0
Bit 13	R	REMOTE_FAULT[1]	0
Bit 12	R	REMOTE_FAULT[0]	0
Bit 11	R	RESERVED	0
Bit 10	R	RESERVED	0
Bit 9	R	RESERVED	0
Bit 8	R	PAUSE[1]	0
Bit 7	R	PAUSE[0]	0
Bit 6	R	HALF_DUPLEX	0
Bit 5	R	FULL_DUPLEX	0
Bit 4	R	RESERVED	0
Bit 3	R	RESERVED	0
Bit 2	R	RESERVED	0
Bit 1	R	RESERVED	0
Bit 0	R	RESERVED	0

The GMII Auto-Negotiation Link Partner Ability Base Page register contains the advertised ability of the link partner's base page. The values contained in the GMII Auto-Negotiation Link Partner Ability Base Page register are guaranteed to be valid either once the Auto-Negotiation has successfully completed, as indicated by the Auto-Negotiation Complete bit in the GMII Status register or when the Page Received bit in the GMII Auto-Negotiation Expansion Register is set to a logic 1.

All of the bits in the GMII Auto-Negotiation Link Partner Ability Base Page register are read only. A write to this register has no effect.

FULL_DUPLEX

If the FULL_DUPLEX bit is set to logic 1, it means that the QuadPHY 1G's Link Partner is capable of operating in full-duplex mode. This bit is initialized to a logic 0.

HALF_DUPLEX

If the HALF_DUPLEX bit is set to logic 1, it means that the QuadPHY 1G's Link Partner is capable of operating in half-duplex mode. This bit is initialized to a logic 0.

PAUSE[1:0]

PAUSE Capabilities. The Link Partner's PAUSE capability is encoded in bits 8:7, and the decodes are shown in the Pause Encoding Table below.

[7]	[8]	Capability
0	0	No PAUSE
0	1	Asymmetric PAUSE toward link partner
1	0	Symmetric PAUSE
1	1	Both Symmetric PAUSE and Asymmetric PAUSE toward local device

REMOTE_FAULT[1:0]

The Link Partner's remote fault condition is encoded in bits 13:12 of the base page. Values are shown in Remote Fault Encoding Table shown below. The default value is 0x00b. The Link Partner indicates a fault by sending a non-zero Remote Fault encoding and during Auto-Negotiation.

[12]	[13]	Description
0	0	No error, link OK
0	1	Offline
1	0	Link_Failure
1	1	Auto-Negotiation_Error

ACKNOWLEDGE

The Acknowledge (Ack) bit is used by the Auto-Negotiation function to indicate that the local device has successfully received its link partner's base page.

Logic 0 = device has not received the message.

Logic 1 = device has received the message.

NEXT_PAGE

The base page and subsequent next pages can set the NEXT_PAGE bit to a logic 1 to indicate that there is additional next pages to be received. Subsequent next pages can set the NEXT_PAGE bit to a logic 0 in order to communicate that there the last page has been received.

Register 0x06: GMII Auto-Negotiation Expansion

Bit	Type	Function	Default
Bit 15	R	RESERVED	0
Bit 14	R	RESERVED	0
Bit 13	R	RESERVED	0
Bit 12	R	RESERVED	0
Bit 11	R	RESERVED	0
Bit 10	R	RESERVED	0
Bit 9	R	RESERVED	0
Bit 8	R	RESERVED	0
Bit 7	R	RESERVED	0
Bit 6	R	RESERVED	0
Bit 5	R	RESERVED	0
Bit 4	R	RESERVED	0
Bit 3	R	RESERVED	0
Bit 2	R	NEXT_PAGE_ABLE	1
Bit 1	R ¹	PAGE_RECEIVED	0
Bit 0	R	RESERVED	0

Notes:

1. This bit latches high and is cleared when read

All of the bits in the GMII Auto-Negotiation Expansion register are read only. A write to this register has no effect.

PAGE_RECEIVED

The PAGE_RECEIVED bit is reset to a logic 0 on a read to the GMII Auto-Negotiation Expansion register. Subsequent to the setting of the Page Received bit, and in order to prevent overlay of the Auto-Negotiation Link Partner Ability Next Page register, the Auto-Negotiation Link Partner Ability Next Page register should be read before the Auto-Negotiation Next Page Transmit register is written.

NEXT_PAGE_ABLE

The Next Page Able bit is set to a logic 1 to indicate that the QuadPHY 1G supports the Next Page function.

Register 0x07: GMII Auto-Negotiation Next Page Transmit

Bit	Type	Function	Default
Bit 15	R/W	NEXT_PAGE	0
Bit 14	R	RESERVED	0
Bit 13	R/W	MESSAGE_PAGE	0
Bit 12	R/W	ACKNOWLEDGE_2	0
Bit 11	R	TOGGLE	0
Bit 10	R/W	MESSAGE_UNFORMATTED_CODE FIELD[10]	0
Bit 9	R/W	MESSAGE_UNFORMATTED_CODE FIELD[9]	0
Bit 8	R/W	MESSAGE_UNFORMATTED_CODE FIELD[8]	0
Bit 7	R/W	MESSAGE_UNFORMATTED_CODE FIELD[7]	0
Bit 6	R/W	MESSAGE_UNFORMATTED_CODE FIELD[6]	0
Bit 5	R/W	MESSAGE_UNFORMATTED_CODE FIELD[5]	0
Bit 4	R/W	MESSAGE_UNFORMATTED_CODE FIELD[4]	0
Bit 3	R/W	MESSAGE_UNFORMATTED_CODE FIELD[3]	0
Bit 2	R/W	MESSAGE_UNFORMATTED_CODE FIELD[2]	0
Bit 1	R/W	MESSAGE_UNFORMATTED_CODE FIELD[1]	0
Bit 0	R/W	MESSAGE_UNFORMATTED_CODE FIELD[0]	0

The GMII Auto-Negotiation Next Page Transmit register contains the advertised ability of the QuadPHY 1G's next page.

MESSAGE_UNFORMATTED_CODE FIELD[10:0]

The MESSAGE_UNFORMATTED_CODE FIELD is an eleven bit wide field, encoding 2048 possible messages. Message Code Field definitions are found in the IEEE 802.3u/Annex 28C.

TOGGLE

The TOGGLE bit is used by the Arbitration function to ensure synchronization with the Link Partner during Next Page exchange. The bit is always set to the opposite value of the Toggle bit in the previously exchanged Link Code Word. The initial value of the Toggle bit in the first Next Page transmitted is the inverse of bit 11 in the base Link Code Word and therefore can assume a value of logic 1 or zero.

ACKNOWLEDGE_2

The ACKNOWLEDGE_2 bit is used by next page function to indicate that a device has the ability to comply with the message. The ACKNOWLEDGE_2 bit is set as follows:

- Logic 0 = device cannot comply with message.
- Logic 1 = will comply with message.

MESSAGE_PAGE

The MESSAGE_PAGE bit is used by the Next Page function to differentiate a Message Page from an Unformatted Page. The MESSAGE_PAGE bit is set as follows:

Logic 0 = Unformatted Page.

Logic 1 = Message Page.

NEXT_PAGE

The NEXT_PAGE bit is used by the Next Page function to indicate whether or not this is the last Next Page to be transmitted. The NEXT_PAGE bit is set as follows:

Logic 0 = Last Page.

Logic 1 = Additional Next Page(s) will follow.

Register 0x08: GMII Auto-Negotiation Link Partner Next Page Ability

Bit	Type	Function	Default
Bit 15	R	NEXT_PAGE	0
Bit 14	R	ACKNOWLEDGE	0
Bit 13	R	MESSAGE_PAGE	0
Bit 12	R	ACKNOWLEDGE_2	0
Bit 11	R	TOGGLE	0
Bit 10	R	MESSAGE_UNFORMATTED_CODE FIELD[10]	0
Bit 9	R	MESSAGE_UNFORMATTED_CODE FIELD[9]	0
Bit 8	R	MESSAGE_UNFORMATTED_CODE FIELD[8]	0
Bit 7	R	MESSAGE_UNFORMATTED_CODE FIELD[7]	0
Bit 6	R	MESSAGE_UNFORMATTED_CODE FIELD[6]	0
Bit 5	R	MESSAGE_UNFORMATTED_CODE FIELD[5]	0
Bit 4	R	MESSAGE_UNFORMATTED_CODE FIELD[4]	0
Bit 3	R	MESSAGE_UNFORMATTED_CODE FIELD[3]	0
Bit 2	R	MESSAGE_UNFORMATTED_CODE FIELD[2]	0
Bit 1	R	MESSAGE_UNFORMATTED_CODE FIELD[1]	0
Bit 0	R	MESSAGE_UNFORMATTED_CODE FIELD[0]	0

The GMII Auto-Negotiation Link Partner Next Page Ability register contains the ability of the link partner's next page. The GMII Auto-Negotiation Link Partner Next Page Ability register is a read only register. Any writes to this register will have no effect.

MESSAGE_UNFORMATTED_CODE FIELD[10:0]

The MESSAGE_UNFORMATTED_CODE FIELD is an eleven bit wide field, encoding 2048 possible messages. Message Code Field definitions are found in the IEEE 802.3u/Annex 28C.

TOGGLE

The TOGGLE bit is used by the Arbitration function to ensure synchronization with the Link Partner during Next Page exchange. The bit is always set to the opposite value of the Toggle bit in the previously exchanged Link Code Word. The initial value of the Toggle bit in the first Next Page transmitted is the inverse of bit 11 in the base Link Code Word and therefore can assume a value of logic 1 or 0.

ACKNOWLEDGE_2

The ACKNOWLEDGE_2 bit is used by next page function to indicate that a device has the ability to comply with the message. The ACKNOWLEDGE_2 bit is set as follows:

Logic 0 = device cannot comply with message.

Logic 1 = will comply with message.

MESSAGE_PAGE

The MESSAGE_PAGE bit is used by the Next Page function to differentiate a Message Page from an Unformatted Page. The MESSAGE_PAGE bit is set as follows:

Logic 0 = Unformatted Page.

Logic 1 = Message Page.

ACKNOWLEDGE

The ACKNOWLEDGE bit is used by the next page function to indicate that a device has received the message. The ACKNOWLEDGE bit is set as follows:

Logic 0 = device has not received the message.

Logic 1 = device has received the message.

NEXT_PAGE

The NEXT_PAGE bit is used by the Next Page function to indicate whether or not this is the last Next Page to be transmitted. The NEXT_PAGE bit is set as follows:

Logic 0 = Last Page.

Logic 1 = Additional Next Page(s) will follow.

Register 0x09 through 0x0E: Reserved

Bit	Type	Function	Default
Bit 15	R	RESERVED	0
Bit 14	R	RESERVED	0
Bit 13	R	RESERVED	0
Bit 12	R	RESERVED	0
Bit 11	R	RESERVED	0
Bit 10	R	RESERVED	0
Bit 9	R	RESERVED	0
Bit 8	R	RESERVED	0
Bit 7	R	RESERVED	0
Bit 6	R	RESERVED	0
Bit 5	R	RESERVED	0
Bit 4	R	RESERVED	0
Bit 3	R	RESERVED	0
Bit 2	R	RESERVED	0
Bit 1	R	RESERVED	0
Bit 0	R	RESERVED	0

Registers 0x09 through 0x0E are reserved for feature use. These registers are read only. Any writes to these registers will have no effect.

Register 0x0F: GMII Extended Status

Bit	Type	Function	Default
Bit 15	R	1000BASE-X_FULL_DUPLEX	1
Bit 14	R	1000BASE-X_HALF_DUPLEX	0
Bit 13	R	1000BASE-T_FULL_DUPLEX	0
Bit 12	R	1000BASE-T_HALF_DUPLEX	0
Bit 11	R	RESERVED	0
Bit 10	R	RESERVED	0
Bit 9	R	RESERVED	0
Bit 8	R	RESERVED	0
Bit 7	R	RESERVED	0
Bit 6	R	RESERVED	0
Bit 5	R	RESERVED	0
Bit 4	R	RESERVED	0
Bit 3	R	RESERVED	0
Bit 2	R	RESERVED	0
Bit 1	R	RESERVED	0
Bit 0	R	RESERVED	0

The Extended Status register is supported by the QuadPHY 1G. All bits in the Extended Status register are read only. Any writes to this register will have no effect.

1000BASE-T_HALF_DUPLEX

This bit will always be read as logic 0, as the QuadPHY 1G does not support 1000BASE-T Half Duplex Operation.

1000BASE-T_FULL_DUPLEX

This bit will always be read as logic 0, as the QuadPHY 1G does not support 1000BASE-T Full Duplex Operation.

1000BASE-X_HALF_DUPLEX

This bit will always be read as logic 0, as the QuadPHY 1G does not support 1000BASE-X Half Duplex Operation.

1000BASE-X_FULL_DUPLEX

This bit will always be read as logic 1, as the QuadPHY 1G has the ability to perform full duplex link transmission and reception using the 1000BASE-X signaling specification.

11.2 PMC-Sierra Specific Registers

Register 0x10: PMC Control 1

Bit	Type	Function	Default
Bit 15	R/W	ENABLE_CHN_D	1
Bit 14	R	RESERVED	0
Bit 13	R/W	ENABLE_CHN_C	1
Bit 12	R	RESERVED	0
Bit 11	R/W	ENABLE_CHN_B	1
Bit 10	R	RESERVED	0
Bit 9	R/W	ENABLE_CHN_A	1
Bit 8	R	RESERVED	0
Bit 7	R/W	COMMA_DETECT_SEL[1]	1
Bit 6	R/W	COMMA_DETECT_SEL[0]	0
Bit 5	R/W	HIGH_AMPLITUDE	1
Bit 4	R	RESERVED	0
Bit 3	R/W	FILTER_COEFFICIENTS [3]	1
Bit 2	R/W	FILTER_COEFFICIENTS [2]	0
Bit 1	R/W	FILTER_COEFFICIENTS [1]	0
Bit 0	R/W	FILTER_COEFFICIENTS [0]	0

The PMC Control 1 register provides control over custom functionality in the QuadPHY 1G. This register controls functionality across all four channels of the device.

FILTER_COEFFICIENTS[3:0]

These bits select the time constants of the digital filter of the clock recovery function. The requirement for advancing the phase of the recovered clock by 1/16 of a baud interval is that the difference between the number of late and early data edges exceeds 4x FILT[3:0]. While the clock phase tracking is not a linear control system, FILT[3:0] provide the capability to track frequency modulation (jitter) on the input waveforms ranging from approximately 1 MHz to 16 MHz without attenuation.

For proper operation, use the default setting. Values 0x1 through 0xF are valid. A value of 0x0 is not valid and should not be used.

HIGH_AMPLITUDE

This bit selects the drive capability for the TDO+ and TDO- terminals. When set to 1, the TDO+/TDO- terminals are configured for high amplitude drive. If the High Amplitude bit is set to 0, the terminals are configured for low amplitude drive.

COMMA_DETECT_SEL[1:0]

These bits enable positive, negative, or both positive and negative comma detection. When COMMA_DETECT_SEL[1] is set to 1, positive comma detection is enabled. Setting COMMA_DETECT_SEL[0] to 1 enables negative comma detection.

ENABLE_CHN_A through D

The ENABLE_CHN bit enables or disables the operation of the associated Channel on the QuadPHY 1G. If these bits are set to a logic 1 the associated channel is enabled. All ENABLE_CHN bits are initialized to a logic 1.

Register 0x11: PMC Control 2

Bit	Type	Function	Default
Bit 15	R/W	TXCLK4	0
Bit 14	R/W	CODE_VIOL_DIS_ENABLE	0
Bit 13	R/W	RESERVED	1
Bit 12	R/W	RESERVED	0
Bit 11	R/W	RESERVED	0
Bit 10	R/W	RESERVED	0
Bit 9	R/W	IPOEN	1
Bit 8	R/W	ENABLE_COMMA_DETECT	1
Bit 7	R/W	INT_DEC_ENC_ENABLE	0
Bit 6	R/W	MDE_CNTRL	0
Bit 5	R/W	INT_MODE_SEL[1]	0
Bit 4	R/W	INT_MODE_SEL[0]	0
Bit 3	R/W	SOFT_RESET	0
Bit 2	R/W	PCS_ENABLE	0
Bit 1	R/W	LINK_TIMER_MODE1	0
Bit 0	R/W	LINK_TIMER_MODE0	0

The PMC Control 2 register provides control over custom functionality in the QuadPHY 1G. This register controls functionality across all four channels of the device.

LINK_TIMER_MODE[1:0]

Link Timer Mode. These bits control the duration of the link timers within the Auto-Negotiation logic.

[1]	[0]	Duration
0	0	16.8ms
0	1	12.6ms
1	0	500ns (test mode)
1	1	250ns (test mode)

PCS_ENABLE

Enable PCS Data Processing (enable = 1). When this bit is set to 1, the chip processes PCS data and treats the parallel interface as GMII (8 bits data plus TX_ER/TX_EN or RX_DV/RX_ER). PCS_ENABLE = 1 takes priority over GEMOD or GE_REG = 1.

SOFT_RESET

Soft Reset (Active High). This bit resets all the logic and state machines in the receive and transmit channels to their original state. This PLL, configuration and status register bits are not affected by the assertion of this bit. This bit is NOT self-clearing. Once set by an MDC/MDIO access, it can be cleared immediately with another MDC/MDIO access. This bit is logically ORed with the SMRESET pin and provides the same functionality.

INT_MODE_SEL[1:0]

The Internal Mode Select bits control the QuadPHY 1G device's mode of operation when the MDE_CNTRL bit is set to a logic 1. The bit definition of the Internal Mode Select bits is shown below.

INT_MODE_SEL[1]	INT_MODE_SEL[0]	Description
0	0	LRRC Mode
0	1	Trunking Mode
1	0	RRRC Mode
1	1	HRRC Mode

If the MDE_CNTRL bit is set to a logic 0, the MODE1 and MODE0 terminals control the QuadPHY 1G's mode of operation.

MDE_CNTRL

The MDE_CNTRL bit is used to select the control mode of the QuadPHY 1G. If set, the IMODE bits control the device mode. If not set, the mode terminals (MODE1, MODE0) control the device mode.

INT_DEC_ENC_ENABLE

The INT_DEC_ENC_ENABLE bit is logically OR'd with the DEC_ENC_EN input terminal. It controls if the Internal Decoder/Encoder is enabled. If it is set to logic 1 the Internal Decoder/Encoder is enabled.

ENABLE_COMMA_DETECT

The ENABLE_COMMA_DETECT bit controls if the Comma Detect is enabled and if byte alignment will be performed on incoming comma sequences. Based on the configuration of the Comma Detect Select Bits in the PMC Control 1 Register, the comma alignment can be programmed to align on positive, negative, or both positive and negative commas. If this bit is set to logic 1, the Comma Detect is enabled.

IPOEN

The IPOEN bit controls the Internal Parallel Output Enable. This bit is logically ANDed with the POEN input terminal. If it is set to logic 1 the Parallel Outputs are enabled.

CODE_VIOL_DIS_ENABLE

The CODE_VIOL_DIS_ENABLE bit controls if the Internal Code Violation/Disparity Code is enabled. When set to logic 1, this bit enables the CV_DIS code function. It is logically OR'd with the CV_DIS_EN input terminal.

TXCLK4

The TXCLK4 bit controls the selection of the Transmit and Receive Clocks. If set to logic 1, four separate TXCK input pins (TXCKD, TXCKC, TXCKB, and TXCKA) are active, each providing the input timing reference for two channels. When set to logic 0, a single TXCK input (TXCKA) is used as the timing reference for all input channels.

Register 0x12: IDLE 1

Bit	Type	Function	Default
Bit 15	R	RESERVED	0
Bit 14	R	RESERVED	0
Bit 13	R	RESERVED	0
Bit 12	R	RESERVED	0
Bit 11	R	RESERVED	0
Bit 10	R	RESERVED	0
Bit 9	R	RESERVED	0
Bit 8	R/W	IDLE_1[8]	1
Bit 7	R/W	IDLE_1[7]	1
Bit 6	R/W	IDLE_1[6]	0
Bit 5	R/W	IDLE_1[5]	1
Bit 4	R/W	IDLE_1[4]	1
Bit 3	R/W	IDLE_1[3]	1
Bit 2	R/W	IDLE_1[2]	1
Bit 1	R/W	IDLE_1[1]	0
Bit 0	R/W	IDLE_1[0]	0

The PMC IDLE 1 register provides programmability for the first Idle code. The PMC IDLE 1 and IDLE 2 registers make up an IDLE pair.

IDLE_1[8:0]

The IDLE_1 Code bits allow the first IDLE character to be programmed. The default is set to 0x1BC (K28.5) when RESET is asserted. This default value is suitable for Gigabit Ethernet applications or for frequency compensation in serial backplane applications.

Register 0x13: IDLE 2

Bit	Type	Function	Default
Bit 15	R	RESERVED	0
Bit 14	R	RESERVED	0
Bit 13	R	RESERVED	0
Bit 12	R	RESERVED	0
Bit 11	R	RESERVED	0
Bit 10	R	RESERVED	0
Bit 9	R	RESERVED	0
Bit 8	R/W	IDLE_2[8]	0
Bit 7	R/W	IDLE_2[7]	0
Bit 6	R/W	IDLE_2[6]	1
Bit 5	R/W	IDLE_2[5]	0
Bit 4	R/W	IDLE_2[4]	1
Bit 3	R/W	IDLE_2[3]	0
Bit 2	R/W	IDLE_2[2]	0
Bit 1	R/W	IDLE_2[1]	0
Bit 0	R/W	IDLE_2[0]	0

The PMC IDLE 2 register provides programmability for the second Idle code. The PMC IDLE and IDLE 2 registers make up an IDLE pair.

IDLE_2[8:0]

The IDLE_2 Code bits allow the second IDLE character to be programmed. The default is set to D16.2 when RESET is asserted. This default value is suitable for Gigabit Ethernet applications only. For frequency compensation in serial backplane applications, this value should be set to 0x11C (K28.0).

Register 0x14: IDLE 1A

Bit	Type	Function	Default
Bit 15	R	RESERVED	0
Bit 14	R	RESERVED	0
Bit 13	R	RESERVED	0
Bit 12	R	RESERVED	0
Bit 11	R	RESERVED	0
Bit 10	R	RESERVED	0
Bit 9	R	RESERVED	0
Bit 8	R/W	IDLE_1A[8]	1
Bit 7	R/W	IDLE_1A[7]	1
Bit 6	R/W	IDLE_1A[6]	0
Bit 5	R/W	IDLE_1A[5]	1
Bit 4	R/W	IDLE_1A[4]	1
Bit 3	R/W	IDLE_1A[3]	1
Bit 2	R/W	IDLE_1A[2]	1
Bit 1	R/W	IDLE_1A[1]	0
Bit 0	R/W	IDLE_1A[0]	0

The PMC IDLE_1A register provides programmability for an alternate first Idle code. The PMC IDLE_1A and IDLE_2A registers make up an IDLE pair.

IDLE_1A[8:0]

The IDLE 1 Alternate Code bits allow the first IDLE character to be programmed. The default is set to K28.5 when RESET is asserted.

Register 0x15: IDLE 2A

Bit	Type	Function	Default
Bit 15	R	RESERVED	0
Bit 14	R	RESERVED	0
Bit 13	R	RESERVED	0
Bit 12	R	RESERVED	0
Bit 11	R	RESERVED	0
Bit 10	R	RESERVED	0
Bit 9	R	RESERVED	0
Bit 8	R/W	IDLE_2A[8]	0
Bit 7	R/W	IDLE_2A[7]	0
Bit 6	R/W	IDLE_2A[6]	1
Bit 5	R/W	IDLE_2A[5]	0
Bit 4	R/W	IDLE_2A[4]	1
Bit 3	R/W	IDLE_2A[3]	0
Bit 2	R/W	IDLE_2A[2]	0
Bit 1	R/W	IDLE_2A[1]	0
Bit 0	R/W	IDLE_2A[0]	0

The PMC IDLE 2 register provides programmability for an alternate second Idle code. The PMC IDLE 1A and IDLE 2A registers make up an IDLE pair.

IDLE_2A[8:0]

The IDLE 2 Alternate Code bits allow the second IDLE character to be programmed. The default is set to D16.2 when RESET is asserted.

Register 0x16: Loopback Control

Bit	Type	Function	Default
Bit 15	R/W	INT_EN_PRI_SERIAL_LPBK_D	0
Bit 14	R/W	INT_EN_SEC_SERIAL_LPBK_D	0
Bit 13	R/W	INT_EN_PRI_SERIAL_LPBK_C	0
Bit 12	R/W	INT_EN_SEC_SERIAL_LPBK_C	0
Bit 11	R/W	INT_EN_PRI_SERIAL_LPBK_B	0
Bit 10	R/W	INT_EN_SEC_SERIAL_LPBK_B	0
Bit 9	R/W	INT_EN_PRI_SERIAL_LPBK_A	0
Bit 8	R/W	INT_EN_SEC_SERIAL_LPBK_A	0
Bit 7	R/W	EN_PAR_LPBK_D	0
Bit 6	R	RESERVED	0
Bit 5	R/W	EN_PAR_LPBK_C	0
Bit 4	R	RESERVED	0
Bit 3	R/W	EN_PAR_LPBK_B	0
Bit 2	R	RESERVED	0
Bit 1	R/W	EN_PAR_LPBK_A	0
Bit 0	R	RESERVED	0

The PMC Loopback Control register provides control over the QuadPHY 1G's serial and parallel loopback capabilities.

EN_PAR_LPBK_A:D

The EN_PAR_LPBK_A:D bits control the loop-back function for the parallel data on each channel. When these bits are set to a logic 1, the associated RXDy[9:0] outputs are routed to the corresponding channel inputs. In normal operation, the TXDy[9:0] inputs are routed to the channel inputs. If the EN_SLPBK pin is asserted, then EN_PAR_LPBK_A:D bits are ignored.

EN_PRI_SERIAL_LPBK_A:D and EN_SEC_SERIAL_LPBK_A:D

The EN_PRI_SERIAL_LPBK_A:D and EN_SEC_SERIAL_LPBK_A:D bits enable the loop-back function for the corresponding serial channel. When set to a logic 1, the QuadPHY 1G routes the internal output of the Serializer to the input of the clock recovery block. The TDO+/TDO- terminals for the selected channel are held in the 1 state as long as this bits are active.

Internal Serial Loop-back must be coordinated with the Redundancy Control Register's (0x1D) Channel Select Bits so that the transmit primary and secondary channels are paired with their receive channel counterparts.

The EN_PRI_SERIAL_LPBK_A:D and EN_SEC_SERIAL_LPBK_A:D bits are logically OR with the input terminal EN_SLPBK.

Register 0x17: Trunking Control

Bit	Type	Function	Default
Bit 15	R/W	INSERT_A_CHAR	0
Bit 14	R/W	A_DELAY[1]	0
Bit 13	R/W	A_DELAY[0]	0
Bit 12	R/W	RESERVED	0
Bit 11	R ¹	DESKEW_STATUS	0
Bit 10	R ¹	PLL_LOCK	0
Bit 9	R	RESERVED	0
Bit 8	R/W	A_CHAR[8]	1
Bit 7	R/W	A_CHAR[7]	0
Bit 6	R/W	A_CHAR[6]	1
Bit 5	R/W	A_CHAR[5]	1
Bit 4	R/W	A_CHAR[4]	1
Bit 3	R/W	A_CHAR[3]	1
Bit 2	R/W	A_CHAR[2]	1
Bit 1	R/W	A_CHAR[1]	0
Bit 0	R/W	A_CHAR[0]	0

Notes:

1. This bit latches low and is set when read

The PMC Trunking Control register provides control over the QuadPHY 1G's Trunking capabilities.

A_CHAR[8:0]

The A_CHAR bits define the Alignment Character for Trunking. The Alignment Character is inserted or deleted to perform and maintain alignment across channels while operating in Trunking Mode. The A_CHAR bits are initialized to 0x17C (K28.3). This function is enabled when the INSERT_A_CHAR bit is set to a logic 1.

PLL_LOCK

The PLL_LOCK bit when 0 indicates that the PLL has lost lock. This failure indication will be sustained until register 0x17 is read even if the PLL regains lock. When PLL_LOCK is a logic 1, this indicates that the PLL has achieved and maintained lock.

DESKEW_STATUS

The DESKEW_STATUS bit when 0 indicates that the deskew state machine within the receive trunking logic has determined that word alignment across channels has been lost. This failure indication will be sustained until register 23 is read even if word alignment across channels is regained. When DESKEW_STATUS is a logic 1, this indicates that the deskew state machine within the receive trunking logic has determined that word alignment across channels has been achieved.

A_DELAY[1:0]

The A_DELAY bits control the delay between the insertions of alignment characters. These bits determine the minimum number of transmit clock cycles between the insertion of alignment characters within the transmit IPG. If the minimum delay occurs during the transition of a packet, the alignment character is inserted into the second byte of the first idle sequence after the packet.

[14]	[13]	Delay
0	0	64 clks
0	1	128 clks
1	0	256 clks
1	1	512 clks

INSERT_A_CHAR

The INSERT_A_CHAR bit enables insertion of an alignment character for Trunking in the transmit IPG. It also enables the deletion of an alignment character on receive channel. The insertion/deletion of alignment characters is enabled when the INSERT_A_CHAR is set to a logic 1.

Register 0x18: PMC Control 3

Bit	Type	Function	Default
Bit 15	R/W	GE_REG	0
Bit 14	R/W	BUSY_REG	0
Bit 13	R/W	RESERVED	0
Bit 12	R/W	INS_DEL_DIS	0
Bit 11	R	RESERVED	0
Bit 10	R/W	A_CHAR_EN	1
Bit 9	R/W	BA_HYSAT_EN	0
Bit 8	R/W	DESKEW_HYST_EN	1
Bit 7	R/W	DIGITAL_LPBK_EN	0
Bit 6	R/W ¹	CODE_ERR_STB	0
Bit 5	R/W	RESERVED	0
Bit 4	R/W	RXCLK4	0
Bit 3	R/W	SYNC_ERR_CODE_EN	0
Bit 2	R	RESERVED	0
Bit 1	R	RESERVED	0
Bit 0	R	RESERVED	0

Notes:

1. When written with a 1, this bit self clears.

The PMC Control 3 register provides control over custom functionality in the QuadPHY 1G. This register controls functionality across all four channels of the device.

SYNC_ERR_CODE_EN

When the SYNC_ERR_CODE_EN bit is set to logic 1, the QuadPHY 1G will output a 0x3FF value on the channel's parallel receive bus, if its synchronization state machine enters the LOSS_OF_SYNC state. The 0x3FF value will be output until the state machine regains synchronization. The operation of SYNC_ERR_CODE_EN is not dependent on the state of the BA_HYST_EN control bit. When the SYNC_ERR_CODE_EN bit is set to logic 0, the state of the channel's synchronization state machine has no effect on the data that is output on its parallel receive bus.

If a particular differential serial input is unconnected (floating) and both the CODE_VIOL_DIS_ENABLE and SYNC_ERR_CODE_EN bits are asserted, the receive bus will output a pure stream of 0x3FFs. Note that it is possible that due to the random nature of the data, that there be an occasional valid code.

RXCLK4

The RXCLK4 bit controls the enabling of the Receive Clocks while operating in LRRC, Trunking or Parallel Loopback Modes. If set to logic 1, the RBCD0 clock is output on the RBCA0, RBCB0, and RBCC0 pins and RBCD1 is output on the RBCA1, RBCB1, and RBCC1 pins. If the RXCLK4 is set to a logic 0, the RBCA0, RBCA1, RBCB0, RBCB1, RBCC0, and RBCC1 pins are inactive while operating in LRRC or Trunking Mode.

CODE_ERR_STB

When 1, CODE_ERR_STB will clear all 8B/10B code error counters within the 8B/10B decoder blocks. The CODE_ERR_STB is self-clearing. When 0, the 8B/10B code error counters will continue to increment on received code errors until the maximum count, CODE_ERR_THR[14:0] is reached. CODE_ERR_THR is equivalent to PKT_CNT[14:0] in the Packet Generator Control register when EN_CODE_ERR_CHK is a 1.

DIGITAL_LPBK_EN

When 1, DIGITAL_LPBK_EN enables the INT_EN_SERIAL_LPBK_[D:A] bits in the Loopback Control register to enable the purely digital loopback path per channel. This path is from the output of the encoder in the transmit path to the input of the byte alignment logic in the receive path. When 0, DIGITAL_LPBK_EN enables the INT_EN_SERIAL_LPBK_[D:A] bits in the Loopback Control register to enable the high-speed serial loopback path. Note that digital loopback is only valid when primary channels are selected. Selecting secondary channels while the DIGITAL_LPBK_EN is asserted is not valid and will cause the part not to function properly.

DESKEW_HYST_EN

When 1, DESKEW_HYST_EN enables the deskew state machine within the receive trunking logic to control when channel to channel realignment can occur. When DESKEW_HYST_EN is a logic 0, alignment will occur whenever alignment characters are recognized in all channels being trunked or when an idle to data transition is recognized in all channels being trunked.

BA_HYST_EN

When 1, BA_HYST_EN enables the byte synchronization state machine within the byte alignment logic to control when the byte alignment logic can realign to a comma. When BA_HYST_EN is a logic 0, the byte alignment logic will realign immediately to a received comma pattern.

A_CHAR_EN

The A_CHAR_EN bit enables or disables the use of an Alignment Character to align data across channels. When the QuadPHY 1G is in Trunking Mode and the A_CHAR_EN bit is set to a logic 1, the Trunking Control Register's A_CHAR[8:0] value is used as the alignment trigger for aligning data across all Receive FIFOs. When A_CHAR_EN is set to a logic 0, the QuadPHY 1G uses the IDLE to DATA transition as the alignment trigger.

INS_DEL_DIS

The INS_DEL_DIS bit controls whether the QuadPHY 1G inserts or deletes IDLEs in to its Receive FIFOs for clock compensation. When the INS_DEL_DIS bit is set to a logic 1, the QuadPHY 1G will not insert and delete IDLEs from its Receive FIFO. If the INS_DEL_DIS bit is set to a logic 0, the QuadPHY 1G inserts and delete IDLEs from its Receive FIFO.

BUSY_REG

The BUSY_REG bit is used to enable or disable the Busy Mode. Busy Mode functionality is only valid when Gigabit Ethernet Mode is enabled. When the BUSY_REG is set to a logic 1, the following function is enabled:

- /K28.5/D10.1/ sequences are treated as non-IDLE. Therefore, they are not modified by the insert/delete logic.

When the BUSY_REG is set to a logic 0, the /K28.5/D10.1/ sequence is treated as IDLE and can be repeated or deleted by the insert/delete logic.

This BUSY_REG bit is logically OR'd with the BMOD input terminal.

GE_REG

The GE_REG bit is used to enable or disable the Gigabit Ethernet Mode. When the GE_REG bit is set to a logic 1, the following functions are enabled :

- Configuration words that pass through the PHY during the Auto-Negotiation process may be inserted/deleted for frequency compensation
- /K28.5/ followed by any non-K character are recognized as an IDLE sequence which can be inserted or deleted for frequency compensation (except when BMOD is asserted, chip will treat /K28.5/D10.1/ as described in BMOD pin description)
- Modify IDLE to correct disparity by substituting /D5.6/ for /D16.2/ in a / K28.5/Dx.y/ transmit IDLE pair.

The GE_REG bit is logically ORed with the GEMOD input terminal. PCS_ENABLE must be set to logic 0 when GE_REG is set to a logic 1.

Register 0x19: Auto-Negotiation Status 1

Bit	Type	Function	Default
Bit 15	R ¹	BASE_PAGE_RX_D	0
Bit 14	R ¹	RESERVED	0
Bit 13	R ¹	BASE_PAGE_RX_C	0
Bit 12	R ¹	RESERVED	0
Bit 11	R ¹	BASE_PAGE_RX_B	0
Bit 10	R ¹	RESERVED	0
Bit 9	R ¹	BASE_PAGE_RX_A	0
Bit 8	R ¹	RESERVED	0
Bit 7	R ¹	NEXT_PAGE_RX_D	0
Bit 6	R ¹	RESERVED	0
Bit 5	R ¹	NEXT_PAGE_RX_C	0
Bit 4	R ¹	RESERVED	0
Bit 3	R ¹	NEXT_PAGE_RX_B	0
Bit 2	R ¹	RESERVED	0
Bit 1	R ¹	NEXT_PAGE_RX_A	0
Bit 0	R ¹	RESERVED	0

Notes:

1. This bit latches high and is cleared when read

The Auto-Negotiation Status 1 register provides Base Page and Next Page reception status for each channel of the QuadPHY 1G.

NEXT_PAGE_RX_A through D

The NEXT_PAGE_RX bit indicates if a Next Page has been successfully received on the specified Channel. All NEXT_PAGE_RX bits are cleared on a read.

BASE_PAGE_RX_A through D

The BASE_PAGE_RX bits indicate if a Base Page has been successfully received on the specified Channel. All BASE_PAGE_RX bits are cleared on a read.

Register 0x1A: Auto-Negotiation Status 2

Bit	Type	Function	Default
Bit 15	R	AN_COMPLETE_D	0
Bit 14	R	RESERVED	0
Bit 13	R	AN_COMPLETE_C	0
Bit 12	R	RESERVED	0
Bit 11	R	AN_COMPLETE_B	0
Bit 10	R	RESERVED	0
Bit 9	R	AN_COMPLETE_A	0
Bit 8	R	RESERVED	0
Bit 7	R ¹	BYTE_ALIGN_STAT_D	0
Bit 6	R ¹	RESERVED	0
Bit 5	R ¹	BYTE_ALIGN_STAT_C	0
Bit 4	R ¹	RESERVED	0
Bit 3	R ¹	BYTE_ALIGN_STAT_B	0
Bit 2	R ¹	RESERVED	0
Bit 1	R ¹	BYTE_ALIGN_STAT_A	0
Bit 0	R ¹	RESERVED	0

Notes:

1. This bit latches low and is set when read

The Auto-Negotiation Status 2 register provides Auto-Negotiation Complete status for each channel of the QuadPHY 1G.

BYTE_ALIGN_STAT_A through D

The BYTE_ALIGN_STAT provide byte alignment status. If the bit for the associated channel is read as a logic 0, it indicates that the byte synchronization state machine within the byte alignment logic for the specified channel has determined that byte alignment has been lost. This failure indication will be sustained until register 0x1A is read even if byte alignment is regained. If the BYTE_ALIGN_STAT bit for the associated channel is read as a logic 1, it indicates that the byte synchronization state machine within the byte alignment logic for the associated channel has determined that byte alignment has been achieved.

AN_COMPLETE_A through D

The AN_COMPLETE bits indicate if the Auto-Negotiation has completed on the specified Channel of the QuadPHY 1G.

Register 0x1B: Packet Generator/Checker Control/Status

Bit	Type	Function	Default
Bit 15	R/W	EN_PKT_GEN	0
Bit 14	R/W	EN_PKT_COMP	0
Bit 13	R/W ¹	ERROR_CNT_RESET	0
Bit 12	R/W ¹	FORCE_ERROR	0
Bit 11	R/W	EN_CODE_ERR_CHK	0
Bit 10	R ²	CODE_ERR_EXCEED	0
Bit 9	R ²	RXFIFO_RESYNC	0
Bit 8	R ²	TXFIFO_RESYNC	0
Bit 7	R	ERROR_CNT[7]	0
Bit 6	R	ERROR_CNT[6]	0
Bit 5	R	ERROR_CNT[5]	0
Bit 4	R	ERROR_CNT[4]	0
Bit 3	R	ERROR_CNT[3]	0
Bit 2	R	ERROR_CNT[2]	0
Bit 1	R	ERROR_CNT[1]	0
Bit 0	R	ERROR_CNT[0]	0

Notes:

1. When written with a 1, this bit self clears.
2. This bit latches high and is cleared when read

The Packet Generator/Checker Control/Status register provides control and status information for QuadPHY 1G's Packet Generator and Checker capabilities. The QuadPHY 1G provides a Packet Generator/Checker Control/Status register for each channel.

ERROR_CNT[7:0]

The ERROR_CNT bits identify the number of errors that have occurred on the associated channel. This counter resets to 0x00h upon set the ERROR_CNT RESET bit. The Error Counter does not rollover when it reaches its maximum count of 0xFFh. It holds the 0xFFh value until it is reset.

TXFIFO_RESYNC

When 1, the TXFIFO_RESYNC bit indicates that the transmit FIFO within the channel has resynchronized its read and write pointers to avoid pointer collision. This resync indication will be sustained until register 0x1B is read.

RXFIFO_RESYNC

When 1, the RXFIFO_RESYNC bit indicates that the Receive FIFO within the channel has resynchronized its read and write pointers to avoid pointer collision. This resync indication will be sustained until register 0x1B is read.

CODE_ERR_EXCEED

When 1, the CODE_ERR_EXCEED bit indicates that the 8B/10B code error counter within the decoder logic has exceeded the error count threshold, CODE_ERR_THR[14 :0]. CODE_ERR_THR is equivalent to PKT_CNT[14 :0] in register 0x1C when EN_CODE_ERR_CHK is a 1. When the error count exceeds the CODE_ERR_THR, CODE_ERR_EXCEED will be sustained as a 1 until register 0x1B is read. The 8B/10B coding error counters in all channels will be cleared whenever the CODE_ERR_STB bit in register 0x18 is set to logic 1.

The Code Error test feature can be used with the Packet Generator enabled and operating in Continuous Test Generation Mode.

EN_CODE_ERR_CHK

When 1, the 8B/10B code error counter within the decoder logic will count received code errors and will indicate that the count has exceeded the CODE_ERR_THR count by setting CODE_ERR_EXCEED to a 1. When 0, the 8B/10B code error counter will be disabled.

FORCE_ERROR

The FORCE_ERROR bit forces the packet generator to create a single byte error in the next data byte or in the next packet if IDLE is currently being generated. This bit is self clearing.

ERROR_CNT_RESET

The ERROR_CNT_RESET bit resets the Error Counter to 0x00h. This bit is self clearing.

EN_PKT_COMP

The EN_PKT_COMP bit enables the Packet Comparator for an associated channel.

EN_PKT_GEN

The EN_PKT_COMP bit enables the Packet Generator for an associated channel.

Register 0x1C: Packet Generator Count Control

Bit	Type	Function	Default
Bit 15	R/W	CONT_TEST_GEN	0
Bit 14	R/W	PKT_CNT[14]	0
Bit 13	R/W	PKT_CNT[13]	0
Bit 12	R/W	PKT_CNT[12]	0
Bit 11	R/W	PKT_CNT[11]	0
Bit 10	R/W	PKT_CNT[10]	0
Bit 9	R/W	PKT_CNT[9]	0
Bit 8	R/W	PKT_CNT[8]	0
Bit 7	R/W	PKT_CNT[7]	0
Bit 6	R/W	PKT_CNT[6]	0
Bit 5	R/W	PKT_CNT[5]	0
Bit 4	R/W	PKT_CNT[4]	0
Bit 3	R/W	PKT_CNT[3]	0
Bit 2	R/W	PKT_CNT[2]	0
Bit 1	R/W	PKT_CNT[1]	0
Bit 0	R/W	PKT_CNT[0]	0

The Packet Generator Count Control register provides control over the Packet Generator capabilities. The QuadPHY 1G provides a Packet Generator Count Control register for each channel.

PKT_CNT[14:0]

The PKT_CNT bits define the total number of frames that the Packet Generator will send for an associated channel.

In order to generate a fixed number of packets, the desired packet count must be first written into PKT_CNT[14:0], then the packet generator must be turned on by setting Bit 15 in register 0x1B to a logic 1 (EN_PKT_GEN). Once the packet generator finishes sending packets, it will go back to sending idle pairs. Additional sets of packets can be generated by toggling the EN_PKT_GEN bit from a logic 0 to a logic 1.

PKT_CNT is also used to define the 8B/10B code error threshold, CODE_ERR_THR, when EN_CODE_ERR_CHK is set to a logic 1. The 8B/10B code error counter within the decoder logic will count received code errors and will indicate that the count has exceeded the CODE_ERR_THR count by setting CODE_ERR_EXCEED to a logic 1. The valid range for the Code Error Threshold is 0x0000 to 0x7FFE. A value of 0x7FFF will not set the CODE_ERR_EXCEED to a logic 1.

CONT_TEST_GEN

The CONT_TEST_GEN bit controls whether the Packet Generator for an associated channel will send continues frames or if it will send the PKT_CNT[14 :0] number of frames. If the CONT_TEST_GEN bit is set to a logic 1, it will send an unlimited number of frames. If it is set to a logic 0, the number of frames will be limited by the value set in the PKT_CNT[14 :0] bits.

Register 0x1D: Redundancy Control

Bit	Type	Function	Default
Bit 15	R/W	RESERVED	0
Bit 14	R/W	RESERVED	0
Bit 13	R/W	RESERVED	0
Bit 12	R/W	RESERVED	0
Bit 11	R/W	TX_CHAN_ENB_D[1]	0
Bit 10	R/W	TX_CHAN_ENB_D[0]	1
Bit 9	R/W	TX_CHAN_ENB_C[1]	0
Bit 8	R/W	TX_CHAN_ENB_C[0]	1
Bit 7	R/W	TX_CHAN_ENB_B[1]	0
Bit 6	R/W	TX_CHAN_ENB_B[0]	1
Bit 5	R/W	TX_CHAN_ENB_A[1]	0
Bit 4	R/W	TX_CHAN_ENB_A[0]	1
Bit 3	R/W	RX_CHN_SEL_D	0
Bit 2	R/W	RX_CHN_SEL_C	0
Bit 1	R/W	RX_CHN_SEL_B	0
Bit 0	R/W	RX_CHN_SEL_A	0

The Redundancy Control register provides control over the selection of the high speed channels primary and secondary inputs and outputs.

It is important to note that during internal serial data loopback testing, channel loopback enable bits in the Loopback control register must be coordinated with the redundancy control register's channel select bits so that transmit primary and secondary channels are paired with their receive channel counterparts.

TX_CHAN_ENB_A:D[1:0]

The TX_CHAN_ENB_A:D bits control which high speed serial output is enabled for channels A thru D.

[1]	[0]	Delay
0	0	Primary Output Disabled Secondary Output Disabled
0	1	Primary Output Enabled Secondary Output Disabled
1	0	Primary Output Disabled Secondary Output Enabled
1	1	Primary Output Enabled Secondary Output Enabled

RX_CHAN_SEL_A:D

The RX_CHAN_SEL_A:D bits control which high speed serial input is selected for channels A thru D. If the receive channel select bit for the associated channel is set to a logic 0, the primary high speed input is selected. If the channel select bit is set to a logic 1, the secondary high speed input is selected.

12 Test Features Description

12.1 Packet Generator and Packet Comparator

There is one packet generator and one packet comparator for each channel in the device. A packet generator is located within the transmit logic of each channel. A packet comparator is located within the receive logic of each channel.

Turning on a particular packet generator causes the transmit logic to ignore data which is present on that lanes transmit parallel input ports. Normally this data is serialized and sent to its respective serial output, however with the packet generator enabled, the output of the packet generator is serialized instead and then sent to its respective serial output.

When a packet comparator is enabled, data which is received goes to both the packet comparator and its respective parallel outputs. This allows the actual data that is received to be snooped if necessary for debug reasons.

The packet generator and comparator can only be operated while the device is configured for LRRC with PCS disabled. Other modes are not supported.

If the TXCLK4 register is set to a logic 1, any packet generator or combination of packet generators can be enabled. The lanes for which packet generators are not enabled can still be used normally, assuming that the corresponding transmit clock is provided. Similarly, when TXCLK4 is set to a logic 0, any packet generator or combination of packet generators may be turned on. However, selecting the packet generator on lane B will disable normal operation on the other lanes.

The purpose of the packet generators and packet comparator is for test and diagnostics of the part, board or system. No logic is included to provide graceful transitions between normal operating and packet generation enabled so transition artifacts are likely to occur at the parallel receiver outputs. When disabling the packet generator, a soft reset is recommended for proper device operation.

12.1.1 Practical Uses of the Packet Generator and Packet Comparators

The most straightforward use of the packet generators and packet comparators is to enable them while in internal serial loopback mode. When used in this manner, the packet generator of channel A communicates to the packet comparator of channel A, the packet generator of channel B communicates to the packet comparator of channel B, etc. By using internal serial loopback and these packet generators and packet comparators, the operation of individual channels can be confirmed within a device. This checks the majority of the analog and digital circuitry within this particular channel, however it does not check analog or digital I/O.

The packet generator of a particular lane does not necessarily have to be used with the packet comparator of that same lane. In fact for a particular serial link, the packet generator of one device can communicate to the packet comparator of another device. This mechanism would be useful in verifying that a particular link is working. This would also test the analog outputs of the packet generating device and the analog inputs of the packet receiving device.

12.1.2 Packet Generator Operation

The packet generator creates a repetitive pattern of packets and IPG. The pattern is created as 8B data. The packet generator is started by setting the EN_PKT_GEN bit (Register 0x1B, bit 15). It sends the number of packets (N) and then idles until it is disabled. The packet data is fixed and contains 256 characters starting with 00h and incrementing to FFh. N ranges from 1 to $(2^{15}-1)$ or is continuous. Register 28 sets N. When the generator is enabled, idle pairs (for IPG) are sent before packets (256 idle pairs), between packets (10 idle pairs) and after the packets continuously until the generator is disabled.

Errors can be introduced into the data packet, for testing the packet comparator logic being stuck-at-0, by setting the FORCE_ERROR bit (Register 0x1B bit 12). This is a self-clearing bit that will create one error each time it is set. An error is created by replacing a character with the repeat of the preceding character instead of the next character in the sequence. For instance, if the FORCE_ERROR bit is sensed during a data packet when 07h is being generated, the character after 07h would normally be 08h, but 07h would be sent in its place. If the FORCE_ERROR bit is sensed during the IPG, SOP or EOP, 00h, 00h, 02h, etc. is sent at the start of the packet instead of the normal 00h, 01h, 02h, etc. Finally, if the error is sensed during FFh, the EOP is replaced with the data character FFh.

12.1.3 Packet Comparator Operation

The packet comparator looks for packets of 256 bytes starting with 00h and incrementing to FFh that are framed by SOP and EOP. Idles are not checked or counted. If SOP is encountered and the subsequent 256 characters are not 00h to FFh and EOP, the error count in Register 0x1B is incremented.

To start the packet checker, EN_PKT_COMP, Register 0x1B, bit 14, must be set to 1. The error count is cleared by setting ERROR_CT_RESET = 1 (Register 0x1B, bit 13). ERROR_CNT_RESET is self-clearing.

Figure 27 Serial Loopback Data Path with Packet Generator/Comparator Enabled

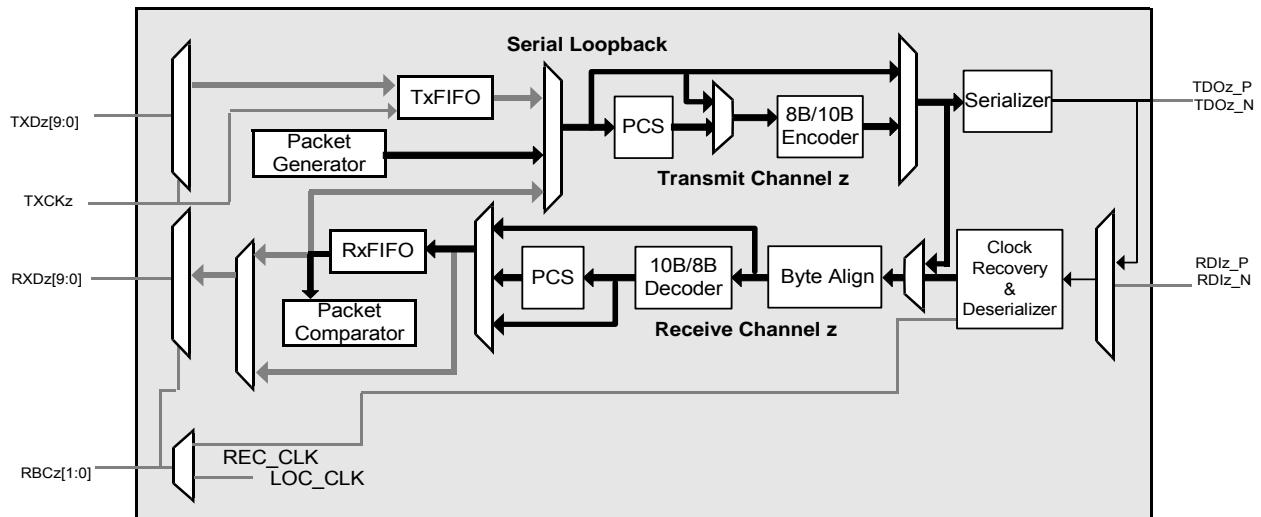

Links between two different QuadPHY 1G devices can also be tested. Enabling the appropriate packet generator in the source QuadPHY 1G device and the packet comparator in the sink QuadPHY 1G device will accomplish this. The packet generator in a source QuadPHY 1G and the packet comparator in the sink QuadPHY 1G must be enabled. Serial Loopback in both devices is disabled.

12.2 JTAG Test Access Port

The QuadPHY 1G JTAG Test Access Port (TAP) allows access to the TAP controller and the 4 TAP registers: instruction, bypass, device identification and boundary scan. Using the TAP, device input logic levels can be read, device outputs can be forced, the device can be identified and the device scan path can be bypassed. For more details on the JTAG port, please refer to the Operations section.

Table 21 Instruction Register

Length - 3 bits

Instructions	Selected Register	Instruction Codes, IR[2:0]
EXTEST	Boundary Scan	000
IDCODE	Identification	001
SAMPLE	Boundary Scan	010
BYPASS	Bypass	011
BYPASS	Bypass	100
STCTEST	Boundary Scan	101
BYPASS	Bypass	110
BYPASS	Bypass	111

Table 22 Identification Register

Length	32 bits
Version number	0x0
Part Number	0x8354
Manufacturer's identification code	0x0CD
Device identification	0x083540CD

13 Operation

13.1 Power-up

The QuadPHY 1G device can start in hardware only mode, without any microprocessor interface in all major operational modes. However, a microprocessor interface is required for testing, debugging and for activating the PCS logic within the QuadPHY 1G, as well as activating various Loopback and packet generation/checking functionality. Table 23 shown pins that are available on the QuadPHY 1G for hardware only configuration.

Power may be applied to the QuadPHY 1G pins in any order. This includes the condition where VDD and VDDA are 1.8 Volts and VDDQ = 2.5 Volts.

13.2 Parallel Interface

The parallel interface uses CMOS input and output buffers that can operate at either 2.5 volt or 1.8 volt levels. The output buffer has an integrated series termination resistor to produce a 50Ω output impedance. The input buffer is a standard CMOS input, with no internal terminations. Figure 28 shows the recommended configuration of the parallel interface.

The interface is designed to operate over un-terminated 50 Ω PCB traces. The maximum length of each trace should not exceed 6 inches. If trace lengths greater than 6 inches are necessary, PMC-Sierra strongly recommends that transmission line modeling and analysis be performed to evaluate the actual performance of the interface.

Figure 28 Parallel Receive and Transmit Interface

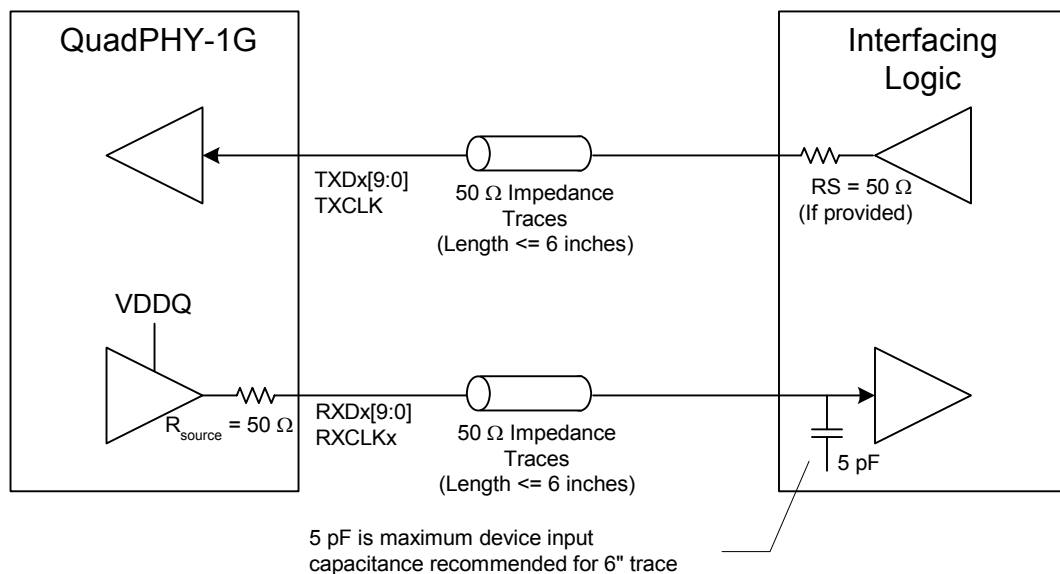

The parallel output drivers of the PM8352 drive traces which connect to the input pins of a receiving device. The minimum high (V_{oh}) and maximum low (V_{ol}) which these inputs see are functions of silicon process variation, temperature and supply voltage of the PM8352. Additionally, voltage levels at the input pins of the receiving device will be affected by the following:

- trace impedance
- length of the interconnecting trace
- input pin capacitance
- frequency of operation

It is important to note that these voltage levels do not necessarily correspond to the V_{oh} and V_{ol} levels that are specified in Table 26 of the D.C. Characteristics section. PMC-Sierra recommends that transmission line modeling and analysis be used to determine the dynamic performance of the interface with a specific application

13.3 High-Speed Serial Interface

As shown in Figure 29, the high-speed serial interface is a set of differential drivers and receivers operating over $50\ \Omega$ transmission lines. The serial transmit outputs are internally terminated, complementary current-sourcing drivers. The serial receive inputs are differential receivers with internal $100\ \Omega$ differential terminations.

For proper operation, all high-speed inputs must be capacitively coupled, as shown in Figure 29. The QuadPHY 1G is internally biased to the proper DC operating point.

The equivalent line length difference between the P and N of the high speed inputs should be less than or equal to 5/16 of an inch (less than 50 ps of skew on FR4 material).

Figure 29 High-Speed Serial Interface

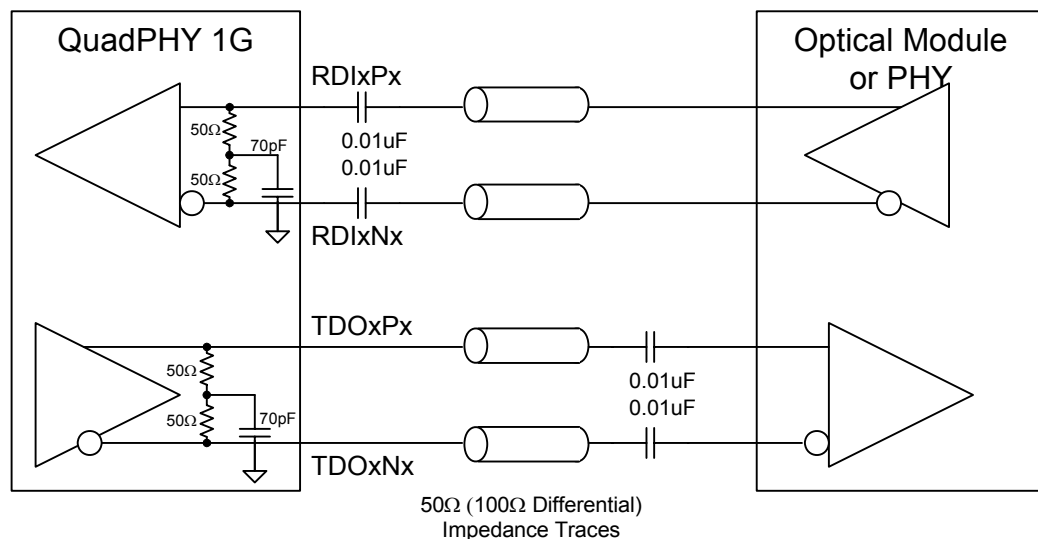

13.4 Clock Requirements

REFCLK is a maximum 125 MHz \pm 100 ppm 40/60 or better oscillator. The maximum jitter allowed is 50 ps peak to peak, or approx 7 ps rms. REFCLK feeds a 2.5/1.8 V CMOS input. The oscillator requires good power supply rejection to provide a low jitter clock input to the device. The driving crystal oscillator may be capacitively coupled to REFCLK and biased around the switching threshold of the REFCLK input.

13.5 Hardware/Software Configuration Options

The following table summarizes the relationships between the terminals and registers used to configure the QuadPHY 1G.

Table 23 Hardware/Software Configuration Options

Function	Terminals	Bit Name (Register Bit)	Relationship with S/W-H/W
8B/10B Encode/Decode	DEC_ENC_EN (J2)	INT_DEC_ENC_ENABLE (Reg 0x11, Bit 7)	OR
Parallel Output Enable	POEN (D13)	IPOEN (Reg 0x11, Bit 9)	AND
Code Violation	CV_DIS_EN (J3)	CODE_VIOL_DIS_ENABLE (Reg 0x11, Bit 14)	OR
Device Mode	MODE1, MODE0 (P12, P11)	INT_MODE_SEL [1:0] (Reg 0x11, Bits 5:4)	*
Gigabit Ethernet Mode (no autonegotiation and non-GMII)	GEMOD (C8)	GE_REG (Reg 0x18, Bit 15)	OR
Busy-Bit Mode	BMOD (P9)	BUSY_REG (Reg 0x18, Bit 14)	OR
Serial Loopback	EN_SLPBK (D7)	INT_EN_PRI_SERIAL_LPBK_ [D:A] (Reg 0x16, Bits 15, 13, 11, 9)	OR
Parallel Loopback	ENPLPBK (N3)	EN_PAR_LPBK_ [D:A] (Reg 0x16, Bits 7, 5, 3, 1)	OR
Insert/Delete Disable	INS_DEL_DIS (M3)	INS_DEL_DIS (Reg 0x18, Bit 12)	OR

* MDE_CNTRL enables the use of the terminals.

13.6 Analog Considerations

A precision resistor must be connected between the RPRES terminal and ground. It is used as a reference for internal bias circuits. The value of RPRES must be $10k\Omega \pm 1\%$.

13.7 JTAG Considerations

A pull-down resistor connected to the QuadPHY 1G's TRSTB pin is recommended to assure that the JTAG TAP Controller remains in a reset state during normal operation of the device.

14 Functional Timing

This section outlines the functional timing for the MDC/MDIO serial port. The functional timing for the receive and transmit parallel ports is described in detail in Sections 10.2.3 and 10.2.4.

14.1 MDC/MDIO Interface

The MDC/MDIO interface is a 2-wire single master, multi-slave protocol. The master device sources the clock (MDC) to all slaves. The tri-state data (MDIO) wire is attached to all devices and is used for reading and writing. Figure 30 contains functional timing for an MDC/MDIO write cycle. A 32-bit preamble (PRE) can optionally be skipped if the STA determines that all PHY devices can handle management frames without it.

Figure 30 MDC/MDIO Write Cycle

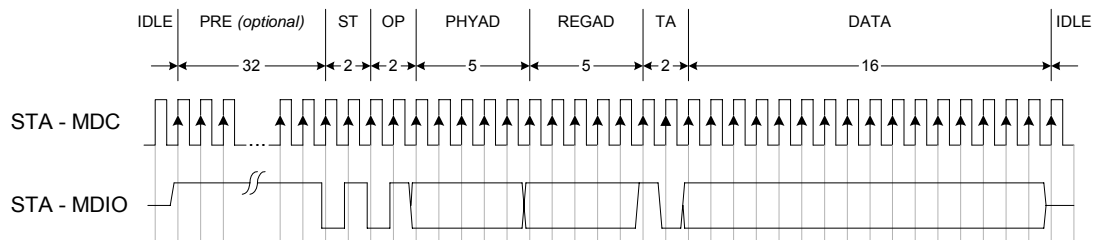
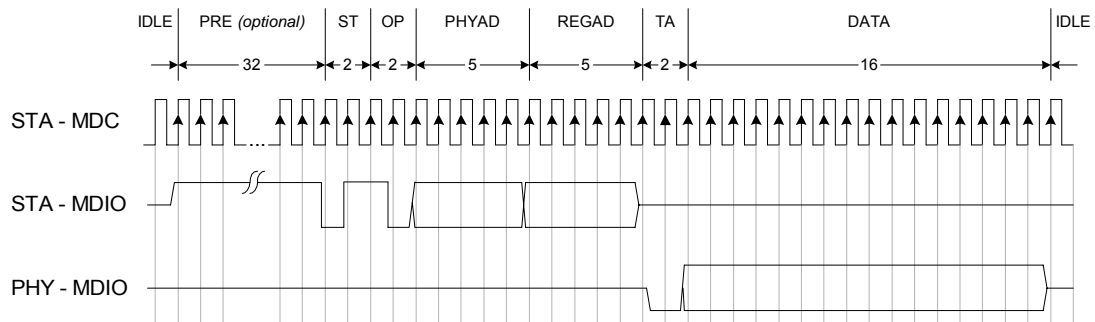

Figure 31 demonstrates an MDC/MDIO read cycle. Here too, the 32 bit preamble can be optionally skipped if the STA determines that all the PHY devices can handle management frames without it.

Figure 31 MDC/MDIO Read Cycle



It is required for a preamble to be applied to the MDC/MDIO interface whenever an error has occurred during an access. This allows the interface to recover from the error. In the case of a free running MDC clock, this can be accomplished by having a pause in the interface, since the MDIO pin is pulled-up when not in use.

Notes:

1. IDLE – Idle. The period when data transfer on MDIO is inactive. The MDC clock may stall until the next transfer or continue to run.
2. PRE[31:0] – Preamble. An optional stream of 32 - 1's which assures the receive logic that a transfer is about to occur.
3. ST[1:0] – Start bits. This is always a 0b01.
4. OP[1:0] – Operation Code. A read is an 0b10 and a write is an 0b01.
5. PHYAD[[4:0] – PHY Address. This is the 5 bit address in which this device compares to its internal address.
6. REGAD[4:0] – Register Address. This is the specific register within the selected address.
7. TA[1:0] – Turn Around Cycle. This is a 2 bit time spacing interval which exists to avoid contention on the MDIO net during a read cycle.
8. DATA[15:0] – Data. This is either read data supplied by the slave or write data supplied by the master.

Figure 32 shows how the MDIO signal transitions during the turn around cycles of a read transaction. These turn around cycles are necessary to avoid contention on the MDIO net.

Figure 32 Behavior of MDIO During TA Field of a Read Transaction

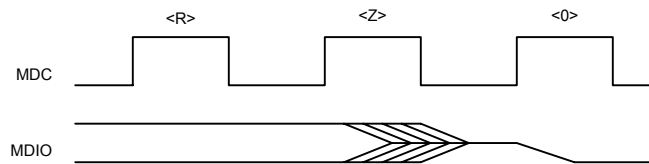

15 Absolute Maximum Ratings

Maximum ratings are the worst case limits that the device can withstand without sustaining permanent damage. They are not indicative of normal mode operation conditions.

Table 24 Maximum Ratings

Case Temperature Under Bias	-40 C to +125 C
Storage Temperature	-40 C to +125 C
1.8V Supply Voltage (VDDI)	-0.3 V to +2.20 V
2.5V Supply Voltage (VDDQ)	-0.3 to +3.12 V
Input pad tolerance	-2 V < Vpin < VDDQ +2 V for 10 ns, 100 mA max
Output pad overshoot limits	-2 V < Vpin < VDDQ +2 V for 10 ns, 100 mA max
Voltage on Digital Input or Bidirectional Pin w/VDDQ at 2.5V	-0.3 V to 3.7 V
Voltage on Digital Input or Bidirectional Pin w/VDDQ at 1.8V	-0.3 V to 3.0 V
Voltage on any Digital Output Pin	-0.3 V to V _{DDQ} + 0.3 V
Voltage on any Differential Pin	-0.3 V to V _{DD} + 0.3 V
Static Discharge Voltage	±1000 V
Latch-Up Current	±100 mA
DC Input Current	±20 mA
Lead/Ball Temperature	+225 +0 -5 °C
Absolute Maximum Junction Temperature	+150 °C

16 Power Information

16.1 Power Requirements

Table 25 Power Requirements

Conditions	Parameter	Typ	Power for Thermal Calculations	Max Current	Units
1 Ports Enabled VDDQ = 1.8V mode 125Mhz	IDD	176	-	252	mA
	IDDA	59	-	99	mA
	IDDQ (10% data transition density)	61	-	209	mA
	Total Power	0.5328	0.77301	-	W
1 Ports Enabled VDDQ = 2.5V mode 125Mhz	IDD	176	-	252	mA
	IDDA	59	-	99	mA
	IDDQ (10% data transition density)	100	-	308	mA
	Total Power	0.673	1.00086	-	W
4 Ports Enabled VDDQ = 1.8V mode 125Mhz	IDD	322	-	451	mA
	IDDA	61	-	102	mA
	IDDQ (50% data transition density)	127	-	213	mA
	Total Power	0.918	1.21716	-	W
4 Ports Enabled VDDQ = 2.5V mode 125Mhz	IDD	322	-	451	mA
	IDDA	61	-	102	mA
	IDDQ (50% data transition density)	198	-	310	mA
	Total Power	1.1844	1.58655	-	W
1 Ports Enabled VDDQ = 1.8V mode 100Mhz	IDD	155	-	224	mA
	IDDA	54	-	95	mA
	IDDQ (10% data transition density)	87	-	290	mA
	Total Power	0.5328	0.79947	-	W

Conditions	Parameter	Typ	Power for Thermal Calculations	Max Current	Units
1 Ports Enabled VDDQ = 2.5V mode 100Mhz	IDD	155	-	224	mA
	IDDA	54	-	95	mA
	IDDQ (10% data transition density)	138	-	421	mA
	Total Power	0.7212	1.14891	-	W
4 Ports Enabled VDDQ = 1.8V mode 100Mhz	IDD	287	-	402	mA
	IDDA	57	-	98	mA
	IDDQ (50% data transition density)	145	-	242	mA
	Total Power	0.9817	1.10565	-	W
4 Ports Enabled VDDQ = 2.5V mode 100Mhz	IDD	287	-	402	mA
	IDDA	57	-	98	mA
	IDDQ (50% data transition density)	230	-	395	mA
	Total Power	1.1942	1.46433	-	W
1 Ports Enabled VDDQ = 1.8V mode 93Mhz	IDD	150	-	218	mA
	IDDA	53	-	88	mA
	IDDQ (10% data transition density)	90	-	351	mA
	Total Power	0.5274	0.80514	-	W
1 Ports Enabled VDDQ = 2.5V mode 93Mhz	IDD	150	-	218	mA
	IDDA	53	-	88	mA
	IDDQ (10% transition)	138	-	453	mA
	Total Power	0.7104	1.167495	-	W
4 Ports Enabled VDDQ = 1.8V mode 93Mhz	IDD	276	-	391	mA
	IDDA	56	-	91	mA
	IDDQ (50% data transition density)	153	-	268	mA
	Total Power	0.873	1.13967	-	W

Conditions	Parameter	Typ	Power for Thermal Calculations	Max Current	Units
4 Ports Enabled VDDQ = 2.5V mode 93 Mhz	IDD	276	-	391	mA
	IDDA	56	-	91	mA
	IDDQ (50% data transition density)	228	-	395	mA
	Total Power	1.1676	1.54476	-	W

Note:

- Outputs loaded with 30 pF (if not otherwise specified), and a normal amount of traffic or signal activity. Power values are calculated using the formula:

$$\text{Power} = \sum_i (\text{VDD} \times \text{IDD})$$
Where i denotes all of the various power supplies on the device, VDD is the voltage for the supply i, and IDD is the current for the supply, i.

16.2 Power Sequencing

Due to ESD protection structures in the pads it is necessary to exercise caution when powering a device up or down. ESD protection devices behave as diodes between power supply pins and from I/O pins to power supply pins. Under extreme conditions, incorrect power sequencing may damage these ESD protection devices or trigger latch up.

The recommended power supply sequencing is as follows:

- This part does not have any power sequencing restrictions.

16.3 Power Supply Filtering

- Use a single plane for both digital and analog grounds.
- Provide separate analog transmit, analog receive, and digital supplies, but otherwise connect the supply voltages together at one point close to the connector where the voltage is brought to the card.
- Ferrite beads are not advisable in digital switching circuits because inductive spiking (di/dt noise) is introduced into the power rail. Simple RC filtering is probably the best approach provided care is taken to ensure the IR drop in the resistance does not lower the supply voltage below the recommended operating voltage.

16.4 Power Supply Decoupling

V_{DD} should be decoupled as close to the pins as possible. The recommended decoupling capacitor size is 0402 or 0603. The ground for the capacitors should be a solid ground plane.

One 0.1 μF decoupling capacitor should be used for every two VDD and VDDQ pins

One 10 μF filtering cap should be used on each of the VDD and VDDQ power rails. Taiyo Yuden PN # LMK325BJ106MN or Panasonic PN # ECJ-3YB0J106K are the recommend components.

In order to minimize the intrinsic jitter on the TDO outputs, RC filtering of the VDDA supply voltage is required. The values shown in Figure 33 were chosen to minimize the IR drop on the VDDA supply voltage, yet provide sufficient filtering of power supply noise at low frequencies.

Figure 33 Recommended Power Supply Decoupling

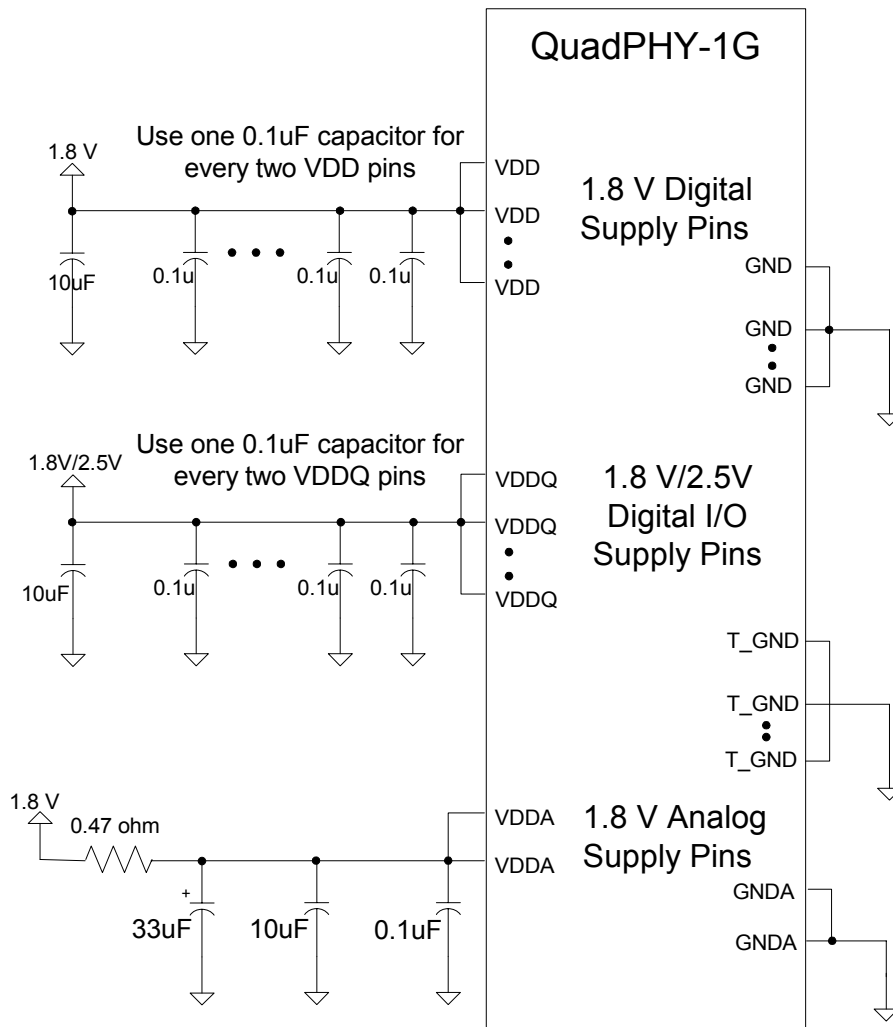

17 D.C. Characteristics

Unless otherwise stated, the following parameters are provided given the following conditions:
 $T_a = -40^\circ\text{C}$ to $T_j = 125^\circ\text{C}$, $V_{DD} = 1.8\text{ V} \pm 5\%$, $V_{DDQ} = 1.8\text{ V} \pm 5\%$ or $2.5\text{ V} \pm 5\%$, $V_{DDA} = 1.8\text{ V} \pm 5\%$

Table 26 D.C. Characteristics

Symbol	Parameter	Min	Typ	Max	Units	Conditions
V_{DD}	Core power supply	1.71	1.80	1.89	V	
V_{DDQ}	I/O power supply VDDQ = 1.8 V VDDQ = 2.5 V	1.71 2.375	1.8 2.5	1.89 2.625	V	
V_{VDDA}	Analog power supply	1.71	1.80	1.89		
V_{IL}	Input Low Voltage VDDQ = 1.8 V VDDQ = 2.5 V			0.59 0.87	V	Guaranteed Input LOW Voltage
V_{IH}	Input High Voltage VDDQ = 1.8 V VDDQ = 2.5 V	1.24 1.63			V	Guaranteed Input HIGH Voltage (note 6)
V_{OL}	Output or Bidirectional Low Voltage VDDQ = 1.8 V VDDQ = 2.5 V			0.3 0.4	V	$I_{OL} = -1.0\text{ mA}$ all outputs
V_{OH}	Output or Bidirectional High Voltage VDDQ = 1.8 V VDDQ = 2.5 V	VDDQ - 0.2 VDDQ - 0.3			V	$I_{OH} = 0.5\text{ mA}$ all outputs
I_{ILPU}	Input Low Current (pull-up terminals)			50	μA	$V_{IL} = 0\text{ V}$ (note 1)
I_{IHPU}	Input High Current (pull-up terminals)			10	μA	$V_{IH} = V_{DDQ}$ (note 1)
I_{ILPD}	Input Low Current (pull-down terminals)			20	μA	$V_{IL} = 0\text{ V}$ (note 3)
I_{IHPD}	Input High Current (pull-down terminals)			50	μA	$V_{IH} = V_{DDQ}$ (note 3)
I_{IL}	Input Low Current			100	μA	$V_{IL} = 0\text{ V}$ (note 2)
I_{IH}	Input High Current			100	μA	$V_{IH} = V_{DDQ}$ (note 2)

Symbol	Parameter	Min	Typ	Max	Units	Conditions
C _{IN}	Input Capacitance (parallel interface and control terminals)	—	1.5	—	pF	T _A = 25 C, f = 1 MHz (note 6)
C _{IO}	Output and Bidirectional Capacitance (parallel interface and control terminals)	—	1.8	—	pF	T _A = 25 C, f = 1 MHz (note 5)
C _{INHS}	Input Capacitance (RDI terminals)	—	1.0	—	pF	T _A = 25 C, f = 1 MHz (note 5)
C _{OUTHS}	Output Capacitance	—	1.0	—	pF	T _A = 25 C, f = 1 MHz (note 5)
L _{PIN}	Pin Inductance	—	2.5	—	nH	T _A = 25 C, f = 1 MHz (note 5)

Notes:

1. Input pin or bi-directional pin with internal pull-up resistor.
2. Input pin or bi-directional pin without internal pull-up resistor.
3. Input pin or bi-directional pin with internal pull-down resistor.
4. Negative currents flow into the device (sinking), positive currents flow out of the device (sourcing).
5. Typical values are given as a design aid. The product is not tested to the typical values given in the data sheet.
6. Input pin is 3.3 V tolerant when VDDQ = 2.5 V.
7. The parallel output data drivers and the clock drivers (RXDx[9:0], RBCx0, RBCx1) have an integrated source series termination. These buffers are designed to drive a 50 Ω unterminated line (maximum recommended length ≤ 6 inches long).

18 Interface Timing Characteristics

Unless otherwise stated, the following parameters are provided given the following conditions:
 $T_a = -40^\circ\text{C}$ to $T_j = 125^\circ\text{C}$, $V_{DD} = 1.8\text{ V} \pm 5\%$, $V_{DDQ} = 1.8\text{ V} \pm 5\%$ or $2.5\text{ V} \pm 5\%$, $V_{DDA} = 1.8\text{ V} \pm 5\%$

18.1 Reference Clock

Table 27 Reference Clock Timing

Symbol	Description	Min	Typ	Max	Units
REFCLK	REFCLK frequency for 933 Mbit/s operation.	93.2907	—	93.3093	MHz
REFCLK	REFCLK frequency for 1.0 Gbit/s operation.	99.9900	—	100.0100	MHz
REFCLK	REFCLK frequency for 1.25 Gbit/s operation.	124.9875	—	125.0125	MHz
DCrefclk	REFCLK duty cycle	40	—	60	%
Peak to peak jitter on REFCLK	Wideband Peak to peak jitter on REFCLK (10 Hz–20 MHz) (RMS jitter is peak to peak jitter divided by 7) Narrowband peak to peak jitter on REFCLK (12 kHz –20 MHz)	—	—	50 20	ps
T_r/T_f , Refclk	REFCLK rise/fall time, 10% - 90% (maximum)	—	1000	—	ps
REFCLK to TXCKy phase deviation	Maximum phase deviation between REFCLK and TXCKy ¹	- 500	—	500	ps
F_lock	Frequency lock after reset	—	—	5.0	ms

Note:

1. The TXCKy and the REFCLK must be synchronous. Once an arbitrary phase relationship is established, the phase deviation must not vary by more than ± 500 ps. Should the phase change more than ± 500 ps, momentary corruption of data may occur.

18.2 Asynchronous Reset

Table 28 QuadPHY 1G Reset Timing

Symbol	Description	Min	Max	Units
t_{RES}	RESET High Pulse Width	500	—	ns
$t_{RESFALL}$	RESET Fall Time	—	10	ns

Figure 34 QuadPHY 1G Reset Timing

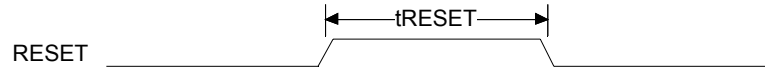

18.3 MII Management Interface (MDC/MDIO)

Table 29 MDIO Timing

Symbol	Description	Min	Max	Units
f_{MDCMAX}	Clock Frequency (MDC)	0	10	MHz
$t_{MDCHIGH}$	MDC High Pulse Width	45	—	ns
t_{MDCLOW}	MDC Low Pulse Width	45	—	ns
$t_{MDCRISE}$	MDC Rise Time ¹	—	5	ns
$t_{MDCFALL}$	MDC Fall Time ¹	—	5	ns
$t_{MDIORISE}$	MDIO Input Rise Time ¹	—	5	ns
$t_{MDIOFALL}$	MDIO Input Fall Time ¹	—	5	ns
t_{MDIO_S}	MDIO Setup Time	10	—	ns
t_{MDIO_H}	MDIO Hold Time	10	—	ns
t_{pMDIO}	MDC to MDIO valid data	0	10	ns
t_{zMDIO}	MDC to MDIO high-impedence	—	10	ns

Notes:

1. MDC or MDIO rise times and fall times are measure from 10% to 90%.
2. For proper operation at the specified maximum MDC frequency, the MDIO load capacitance must not exceed 470 pF while operating up to 2.5 MHz and 100 pF while operating up to 10 MHz.

Figure 35 MDIO Timing Diagram

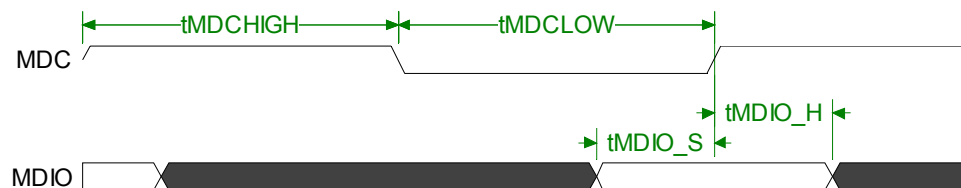
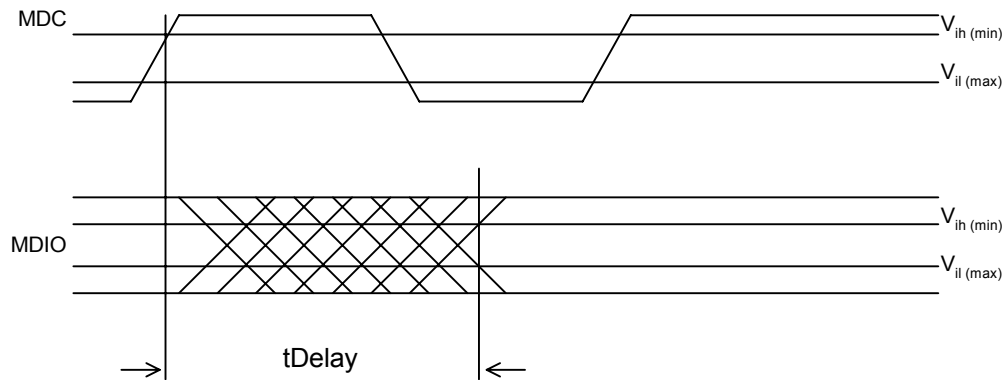

Figure 36 MDIO Sourced by PHY



18.4 JTAG

Table 30 JTAG Port Interface

Symbol	Description	Min	Max	Units
—	TCK Frequency	—	1	MHz
—	TCK Duty Cycle	40	60	%
t_{STMS}	TMS Set-up time to TCK	50	—	ns
t_{HTMS}	TMS Hold time to TCK	50	—	ns
t_{STDI}	TDI Set-up time to TCK	50	—	ns
t_{HTDI}	TDI Hold time to TCK	50	—	ns
t_{PTDO}	TCK Low to TDO Valid	2	50	ns
t_{VTRSTB}	TRSTB Pulse Width	100	—	ns
$t_{TRSTBRISE}$	TRSTB Rise Time	—	10	ns

Figure 37 JTAG Port Interface Timing

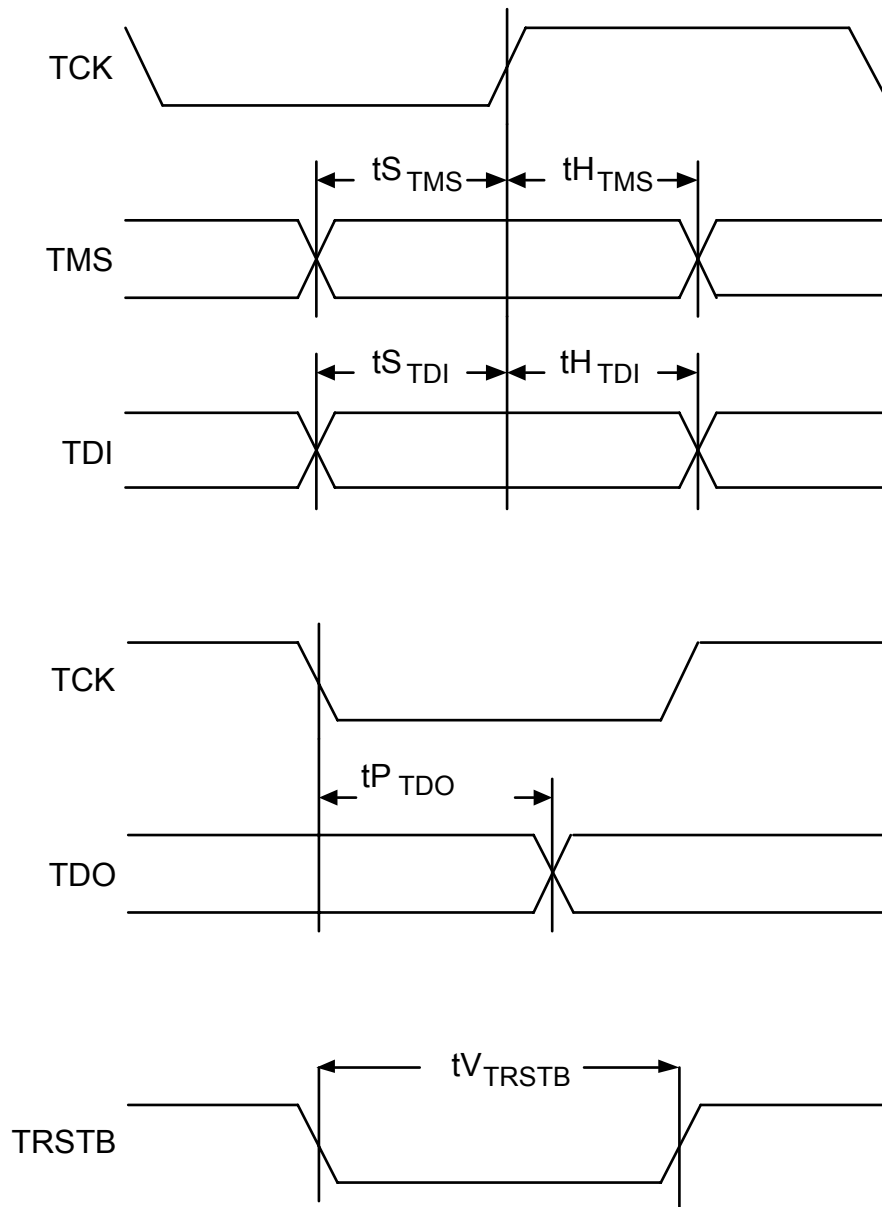

Notes on Input Timing

1. When a set-up time is specified between an input and a clock, the set-up time is the time in nanoseconds from the $V_{DD}/2$ Volt point of the input to the $V_{DD}/2$ Volt point of the clock.
2. When a hold time is specified between an input and a clock, the hold time is the time in nanoseconds from the $V_{DD}/2$ Volt point of the clock to the $V_{DD}/2$ Volt point of the input.

Notes on Output Timing

1. Output propagation delay time is the time in nanoseconds from the $V_{DD}/2$ Volt point of the reference signal to the $V_{DD}/2$ Volt point of the output.

2. Maximum output propagation delays are measured with a 50 pF load on the outputs

18.5 Transmit Timing

Table 31 Transmit Timing

Number	Symbol	Parameter	Min	Typ	Max	Unit
1	t_{TS}	TXD setup time to TXCK (93.3 MHz)	1.4	—	—	ns
		TXD setup time to TXCK (100 MHz)	1.4	—	—	ns
		TXD setup time to TXCK (106 MHz)	1.4	—	—	ns
		TXD setup time to TXCK (125 MHz)	1.4	—	—	ns
2	t_{TH}	TXD hold time from TXCK (93.3 MHz)	0.0	—	—	ns
		TXD hold time from TXCK (100 MHz)	0.0	—	—	ns
		TXD hold time from TXCK (106 MHz)	0.0	—	—	ns
		TXD hold time from TXCK (125 MHz)	0.0	—	—	ns

Figure 38 Parallel Transmit Timing (All Modes)

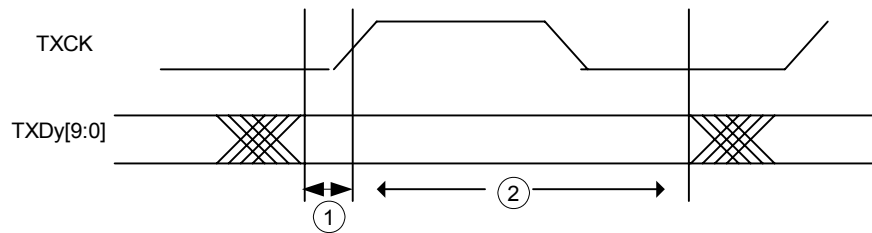

18.6 Receive Timing

Table 32 Receive Timing

Number	Symbol	Parameter	Min	Typ	Max	Unit
3	t_{RDV}	RXD valid before RBCA, RBCB, RBCC, RBCD				
		LRRC or Trunking Modes (93.3 MHz)	2.5	—	—	ns
		LRRC or Trunking Modes (100 MHz)	2.5	—	—	ns
		LRRC or Trunking Modes (106 MHz)	2.5	—	—	ns
		LRRC or Trunking Modes (125 MHz)	2.5	—	—	ns
		RXD valid before RBC				
		RRRC Mode (93.3 MHz)	2.5	—	—	ns
		RRRC Mode (100 MHz)	2.5	—	—	ns
4	t_{HRDV}	RRRC Mode (106 MHz)	2.5	—	—	ns
		RRRC Mode (125 MHz)	2.5	—	—	ns
4	t_{HRDV}	RXD valid before RBC				

		HRRC Mode (93.3 MHz)	2.5	—	—	ns
		HRRC Mode (100 MHz)	2.5	—	—	ns
		HRRC Mode (106 MHz)	2.5	—	—	ns
		HRRC Mode (125 MHz)	2.5	—	—	ns
5	t _{RDH}	RXD hold after RBCA, RBCB, RBCC, RBCD LRRC or Trunking Modes (93.3 MHz)	0.5	—	—	ns
		LRRC or Trunking Modes (100 MHz)	0.5	—	—	ns
		LRRC or Trunking Modes (106 MHz)	0.5	—	—	ns
		LRRC or Trunking Modes (125 MHz)	0.5	—	—	ns
		RXD hold after RBC RRRC Mode (93.3 MHz)	0.5	—	—	ns
		RRRC Mode (100 MHz)	0.5	—	—	ns
		RRRC Mode (106 MHz)	0.5	—	—	ns
		RRRC Mode (125 MHz)	0.5	—	—	ns
6	t _{HRDH}	RXD hold after RBC HRRC Mode (93.3 MHz)	1.5	—	—	ns
		HRRC Mode (100 MHz)	1.5	—	—	ns
		HRRC Mode (106 MHz)	1.5	—	—	ns
		HRRC Mode (125 MHz)	1.5	—	—	ns
—	t _{RDR}	Output rise time, 10%–90%, 10pF load for RBC[D:A] (Note 9)	—	—	1.0	ns
—	t _{RDF}	Output fall time, 90%–10%, 10pF load for RBC[D:A] (Note 9)	—	—	1.0	ns
—	t _{duty}	Output RBC[D:A] Duty Cycle	40	—	60	%
—	B_sync	Receive data phase-lock time	—	—	500	Bit times
—	t _{RXFTOL}	REFCLK/input data frequency difference	-200	—	200	ppm
	t _{SKEW}	Channel-to-Channel skew tolerance across all channels (Trunking Mode)			40	Bit times

Notes:

1. The outputs are 50 ohm source series internally terminated and are designed to drive a 50 ohm unterminated transmission line. The specifications are provided for reference when driving capacitive loads. Capacitive loads should be consistent across all data and clock pins on the Receive interface. PMC-Sierra strongly recommends that all trace lengths be matched on the Receive interface.
2. t_{SKEW} is an absolute value that assumes a maximum packet size of 20,000 bytes, Trunking Mode with all 8 Channels enabled, DESKEW_HYST_EN bit set to a logic 1, and a ±200 ppm REFCLK/input data frequency difference. For additional information on Channel-to-Channel skew tolerance, refer to the Maximum Size Packets Supported section.
3. B_sync has been verified by design. Please refer to Clock and Data Recovery description in section 10.2.4 for conditions which impact B_sync.

Figure 39 Parallel Receive Timing Diagram for LRRC, Trunking, and RRRC Mode

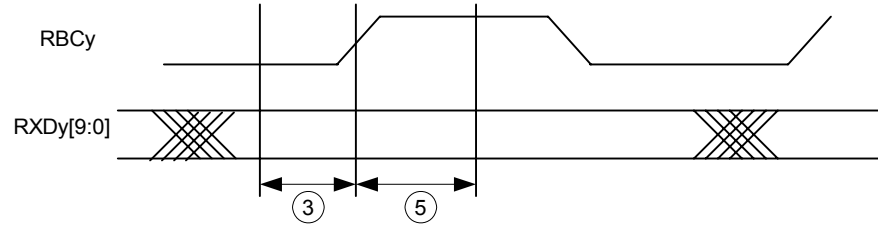
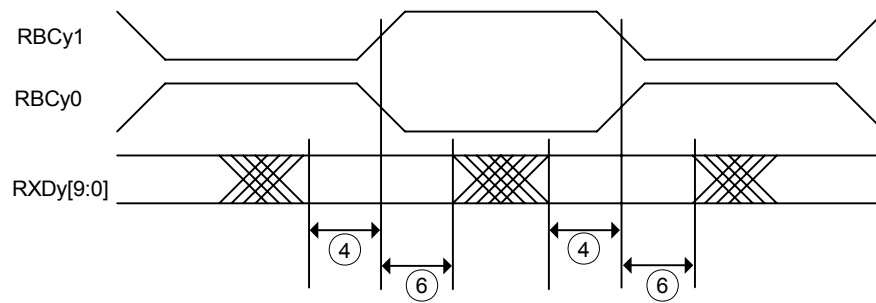

Figure 40 Parallel Receive Timing Diagram for HRRC Mode



18.7 Receive Latency

Table 33 Receive Latency Timing

Number	Symbol	Parameter	Min	Typ	Max	Unit
5	t _{RXLAT}	Receiver latency				
		LRRC/Trunking w/ decoder enabled – PCS off and GEMOD off	105	—	285	Bits
		LRRC/Trunking w/ decoder enabled – PCS off and GEMOD on	125	—	305	Bits
		LRRC w/ decoder enabled - PCS on	165	—	345	Bits
		LRRC w/ decoder disabled	95	—	275	Bits
		RRRC decoder enabled, PCS off	30	—	50	Bits
		RRRC decoder enabled, PCS on	100	—	120	Bits
HRRC/RRRC decoder disabled, PCS off	20	—	40	Bits		

Note:

- The receiver latency, as shown in Figure 41 is defined as the time between receiving the first serial bit of a word and the clocking out of that parallel word (Defined by the rising edge of REFCLK) when in RRRC Mode. If the FIFO is used, latency may increase.

Figure 41 Receive Latency

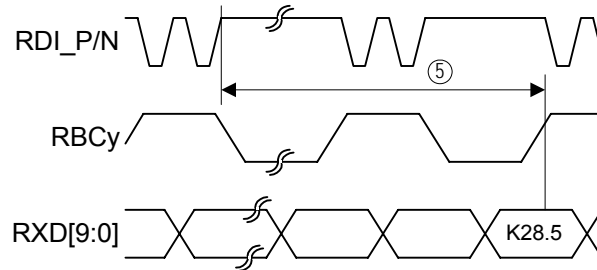

18.8 Transmit Latency

Table 34 Transmit Latency Timing

Number	Symbol	Parameter	Min	Typ	Max	Unit
6	t _{TXLAT}	Transmitter latency ⁶				
		- encoder disabled, PCS off	55	—	80	Bits
		- encoder enabled, PCS off	75	—	100	Bits
		- encoder enabled, PCS on	81	—	116	Bits

Note:

- The transmitter latency, as shown in Figure 42, is defined as the time between the latching in of the parallel data word and the transmission of the first serial bit of that parallel word (defined by the leading edge of the first bit transmitted).

Figure 42 Transmit Latency

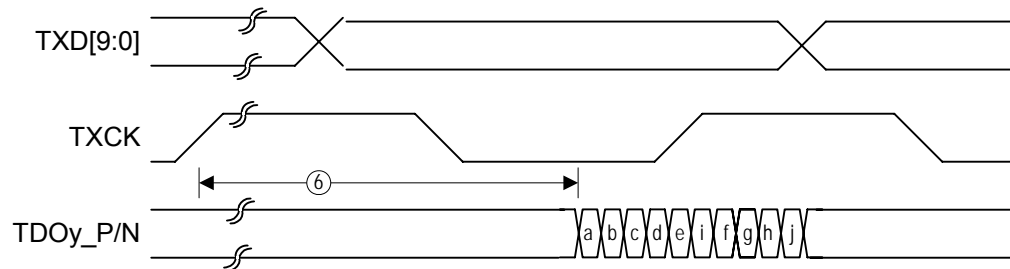

⁶ independent of operating mode

18.9 High-speed Serial Timing Characteristics

Figure 43 933 Mbit/s to 1.25 Gbit/s Serial I/O Block Diagram

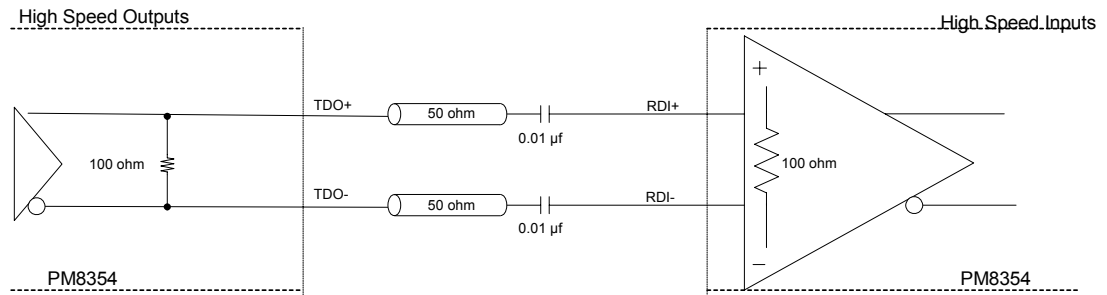

Note:

1. The differential (100 Ω) terminating resistors have been implemented on-chip within the high-speed input buffer and should not be placed on the PC board. The capacitors are DC blocking caps. The TDO and RDI do not have the same common mode bias.

Figure 44 Differential Peak-Peak Receiver Eye Diagram

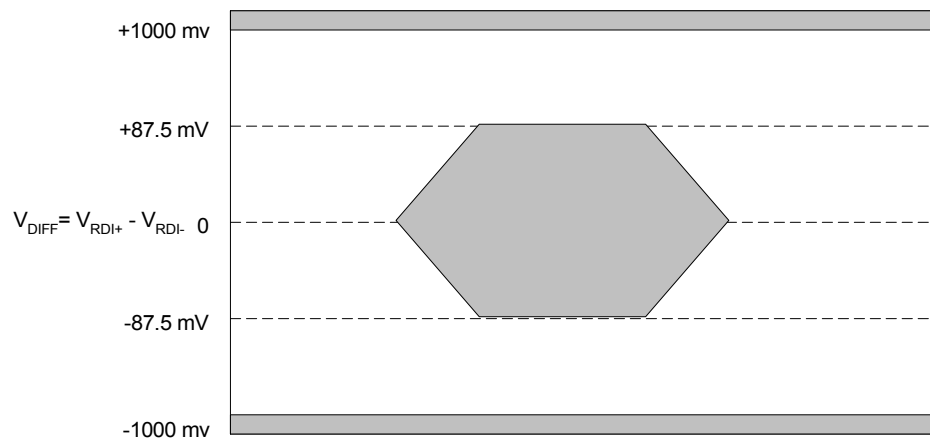

Note:

1. Minimum differential sensitivity (peak to peak) is 2x the magnitude of the minimum physical potential that can be expected across the differential pair.

V_{DIFF} can be +100 mV for logic 1 or -100 mV for logic 0.

When viewing a data eye on an oscilloscope using a differential probe across terminals A and B, the top and bottom of the eye will have a maximum separation of $V_{diff\ peak\ to\ peak}$. If the same signal is measured using a single ended probe attached to terminal A and referenced to GND, the top and bottom of the eye will have a maximum vertical separation of $|V_{diff}|$. The single ended measurement technique will yield a vertical eye opening equal to $\frac{1}{2}$ the vertical eye opening of the differential measurement technique.

Definitions

- V_{diff} Voltage of terminal A – Voltage of terminal B. V_{diff} swings both positive and negative in value.
- $|V_{diff}|$ The magnitude of V_{diff} . V_{diff} is always a positive number and represents the maximum voltage that can exist between terminals A and B.
- $V_{diff\ peak\ to\ peak}$ Represents the peak to peak difference of the differential voltage V_{diff} . $V_{diff\ p-p}$ will always be twice the magnitude of the maximum voltage that can exist between terminals A and B.

Table 35 High-speed I/O Characteristics ($V_{DD} = 1.8\ V$)

Symbol	Parameter	Min	Typ.	Max	Unit
$ V_{RDI+} - V_{RDI-} $	High-speed input differential voltage magnitude	87.5	—	1000	mV pk differential
$V_{ID(ppk)}$ Note 1	High-speed input peak-peak differential voltage	175	—	2000	mV pk – pk differential
$V_{OD(ppk)}$ Note 1	High-speed output peak-peak differential voltage (High Amplitude Mode)	1070	—	1405	mV pk – pk differential
$V_{OD(ppk)}$ Note 1	High-speed output peak-peak differential voltage (Low Amplitude Mode)	646	—	839	mV pk – pk differential
t_r, t_f Note 2	High-speed output rise and fall times, 20 % – 80 %	100	—	200	ps
t_{SKEW}	Differential Output Skew between high-speed output terminals TDOx_P/_N	—	—	30	ps

Note 1:

- High-speed output peak-to-peak differential voltages are measured with 100 ohm external differential termination at the pin of the device.

Note 2:

- Rise and fall times (t_r and t_f) measured with board trace, connector and approximately 2.5 pf load.

Table 36 Gigabit Ethernet Jitter Specifications²

T_J	Total output jitter	—	—	0.240	UI pk-pk
T_{DJ}	Deterministic output jitter	—	—	0.100	UI pk-pk
R_{RJt}^1	Total Jitter Tolerance	—	—	0.749	UI pk-pk
R_{DJT}	Deterministic Jitter Tolerance	—	—	0.462	UI pk-pk

Table 37 Fibre Channel Jitter Specifications³

T _J	Total output jitter	—	—	0.21	UI pk-pk
T _{DJ}	Deterministic output jitter	—	—	0.10	UI pk-pk
R _{RJT}	Total Jitter Tolerance	—	—	0.70	UI pk-pk
R _{DJT}	Deterministic Jitter Tolerance	—	—	0.38	UI pk-pk
R _{SJT}	Sinusoidal Jitter Tolerance	—	—	0.10	UI pk-pk

Notes:

1. Total jitter is composed of both deterministic and random components. The allowed random jitter equals the allowed total jitter minus the actual deterministic jitter.
2. The jitter values that are specified in Table 36 assume the presence of only high-frequency jitter components that are not tracked by the clock recovery circuit. For the Gigabit Ethernet Standard the lower cutoff frequency for jitter is 750 kHz.
3. The jitter values that are specified in Table 37 assume the presence of only high-frequency jitter components that are not tracked by the clock recovery circuit. For the Fibre Channel Standard the lower cutoff frequency for jitter is 637 kHz for 1.0625Gbit/s operation.
4. The Fibre Channel jitter values that are specified in Table 37 are applicable to 933Mbit/s operation.

18.10 Terminal Input Capacitance

Symbol	Parameter	Min	Typ.	Max	Units
C _{in}	Input capacitance on low-speed input terminals		1		pF

19 Ordering & Thermal Information

19.1 Ordering Information

Table 38 Ordering Information

Part Number	Description
PM8354-NI	289-Pin Chip Array Ball Grid Array (CABGA)
PM8354-NGI	289-Pin CABGA, 19 x 19 x 1.66 mm, 1.00 mm BP (RoHS-compliant)
PM8354A-NI	289-Pin CABGA
PM8354A-NGI	289-Pin CABGA, 19 x 19 mm ² , 1.00 mm BP (RoHS-compliant)

This product is designed to operate over a wide temperature range and is suited for outside plant equipment.

19.2 Thermal Information

This product is designed to operate over a wide temperature range and is suited for outside plant equipment.

Table 39 Outside Plant Thermal Information

Maximum long-term operating junction temperature (T_J) to ensure adequate long-term life	105 °C
Maximum junction temperature (T_J) for short-term excursions with guaranteed continued functional performance ² . This condition will typically be reached when local ambient reaches 85 °C.	125 °C
Minimum ambient temperature (T_A)	-40 °C

Table 40 Thermal Resistance vs. Air Flow³

Airflow	Natural Convection	200 LFM	400 LFM
θ_{JA} (°C/W)	25.6	21.6	17.3

Table 41 Device Compact Model⁴

Junction-to-Top Thermal Resistance, θ_{JT}	7 °C/W
Junction-to-Board Thermal Resistance, θ_{JB}	16 °C/W

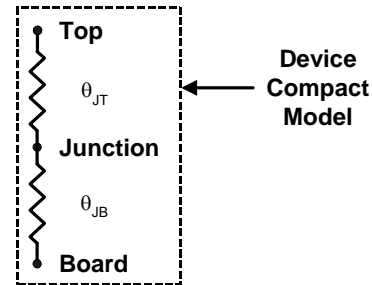

Power depends upon the operating mode. Please refer to Table 29 D.C Characteristics to determine operating power.

Notes:

1. The minimum ambient temperature requirement for Outside Plant Equipment meets the minimum ambient temperature requirement for Industrial Equipment.
2. Short-term is used as defined in Telcordia Technologies Generic Requirements GR-63-Core Core.
3. θ_{JA} is the total junction to ambient thermal resistance as measured according to JEDEC Standard JESD51 (2S2P).
4. The junction-to-top thermal resistance, θ_{JT} , is obtained by simulating conditions described in SEMI Standard G30-88. The junction-to-board thermal resistance, θ_{JB} , is obtained by simulating conditions described in JEDEC Standard JESD 51-8.

This product is designed to operate over a wide temperature range when used with a heat sink and is suited for use in an outside plant.

Table 42 Outside Plant Thermal Information

Maximum long-term operating junction temperature (T_J) to ensure adequate long-term life.	105 °C
Maximum junction temperature (T_J) for short-term excursions with guaranteed continued functional performance ² . This condition will typically be reached when the local ambient temperature reaches 85 °C.	125 °C
Minimum ambient temperature (T_A)	-40 °C

Table 43 Device Compact Model

Junction-to-Case Thermal Resistance, θ_{JC}	7 °C/W
Junction-to-Board Thermal Resistance, θ_{JB}	16 °C/W

Table 44 Heat Sink Requirements

θ_{SA} ⁴ θ_{CS} ⁴	The sum of $\theta_{SA} + \theta_{CS}$ must be less than or equal to: $[(105 - T_A) / P_D] - \theta_{JC}$ °C/W where: T_A is the ambient temperature at the heatsink location P_D is the operating power dissipated in the package
θ_{SA} and θ_{CS} are required for long-term operation ⁵	

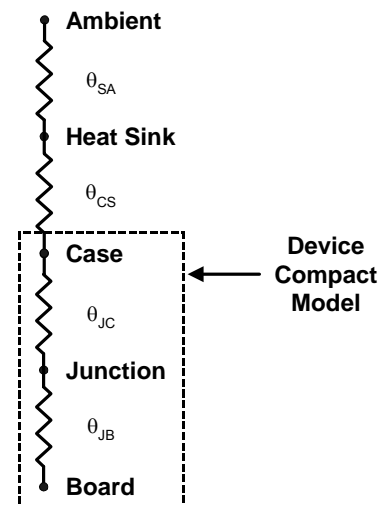

Operating power depends upon the operating mode. Please refer to Table 29 D.C Characteristics to determine operating power..

Notes:

1. The minimum ambient temperature requirement for Outside Plant Equipment approximates the minimum ambient temperature requirement for Industrial Equipment
2. Short-term is used as defined in Telcordia Technologies Generic Requirements GR-63-Core
3. The junction-to-case thermal resistance, θ_{JC} , is a measured nominal value plus two sigma. The junction-to-board thermal resistance, θ_{JB} , is obtained by simulating conditions described in JEDEC Standard JESD 51-8
4. θ_{SA} is the thermal resistance of the heat sink to ambient. θ_{CS} is the thermal resistance of the heat sink attached material. The maximum θ_{SA} required for the airspeed at the location of the device in the system with all components in place

20 Mechanical Information

This mechanical package diagram QuadPHY 1G's 289 Pin CABGA Package is shown in Figure 45. After assembly, the QuadPHY 1G is tested to meet or exceed a 0.15mm (5.9mil) coplanarity specification.

Figure 45 Mechanical Drawing 289 Pin CABGA

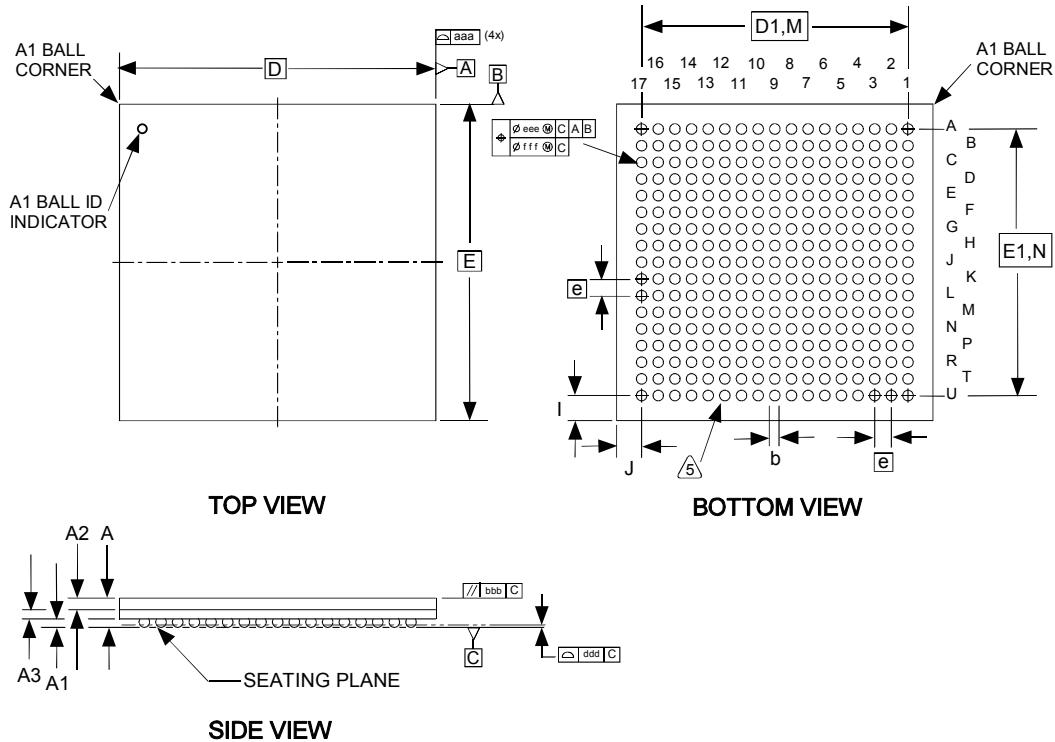

- NOTES: 1) ALL DIMENSIONS IN MILLIMETER.
 2) DIMENSION aaa DENOTES PACKAGE BODY PROFILE.
 3) DIMENSION bbb DENOTES PARALLEL.
 4) DIMENSION ddd DENOTES COPLANARITY.
 5) SOLDER MASK OPENING 0.40 +/- 0.03 MM DIAMETER (SMD).
 6) PACKAGE COMPLIANT TO JEDEC REGISTERED OUTLINE MO-205, VARIATION BD.

PACKAGE TYPE : 289 CHIP ARRAY BALL GRID ARRAY - CABGA																		
BODY SIZE : 19 x 19 x 1.76 MM																		
Dim.	A	A1	A2	A3	D	D1	E	E1	M,N	I	J	b	e	aaa	bbb	ddd	eee	fff
Min.	1.61	0.40	0.65	0.56	-	-	-	-	-	-	-	-	-	-	-	-	-	-
Nom.	1.76	0.50	0.70	0.56	19.00 BSC	16.00 BSC	19.00 BSC	16.00 BSC	17x17	1.50	1.50	0.50	1.00 BSC	-	-	-	-	-
Max.	1.91	0.60	0.75	0.56	-	-	-	-	-	-	-	-	-	0.20	0.25	0.15	0.25	0.10

Notes