

**COAX CONTACT  
SERIES**

**Size 8 Coax Contacts**

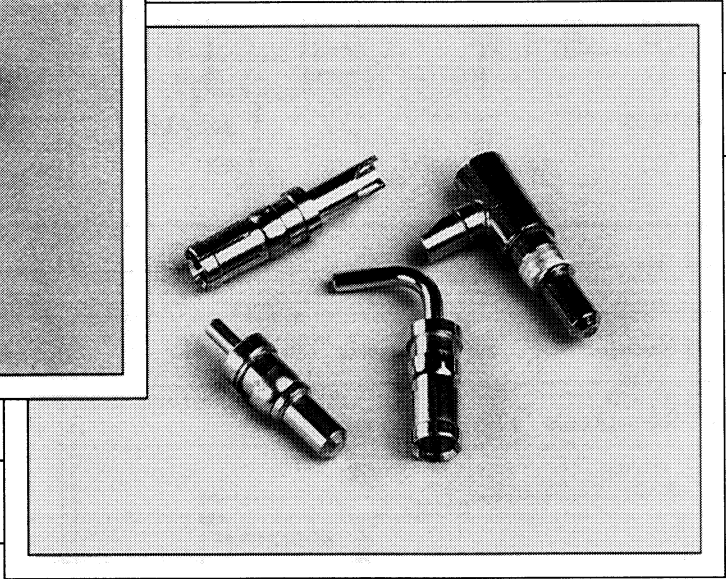
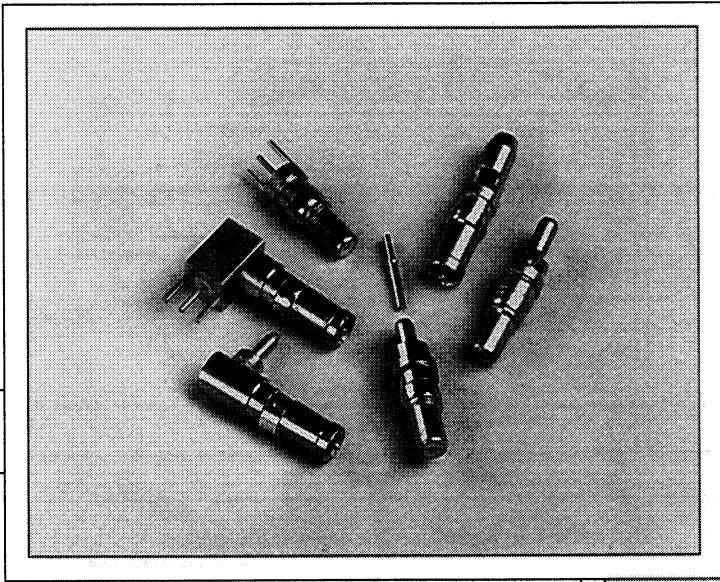

**Size 8 Coax - Industry Standard Contacts**

<b>PDM 15 Series (Industry Standard)</b> .....	.112
Specifications / Interface Drawings .....	.113
Product Data .....	.114-118

# PDM STANDARD 15 SERIES

*SPECIFICATIONS SUBJECT TO CHANGE WITHOUT NOTICE*

## MECHANICAL

### MATERIALS

Plug Bodies: Brass per ASTM B 16.  
 Receptacle Bodies: Beryllium Copper per ASTM B 196.  
 Insulation: Teflon (PTFE) per ASTM D 1457.  
 Retaining Ring: Beryllium Copper per ASTM B 194.  
 Contacts, Male: Brass per ASTM B 16.  
 Contacts, Female: Beryllium Copper per ASTM B 196.

### PLATING

Gold per MIL-G-45204.  
 Copper per MIL-C-14550.  
 Nickel per QQ-N-290.

## FINISH (Add letter to end of part number.)

### BODIES AND CONTACTS\*

"A": .000050 Min. Gold over Nickel.  
 "B": .000030 Min. Gold over Nickel.  
 "C": .000050 Min. Gold over Copper.  
 "D": .000030 Min. Gold over Copper.  
 \*\*\*"F": .000010 Min. Gold over Nickel  
 "H": Non-Magnetic - .000050 Min. Gold over Copper.  
 Residual Magnetism less than 20 Gamma.

## MATING CHARACTERISTICS

Outer Bodies: 3 lbs. Max. Insertion.  
 2 oz. Min. Withdrawal.  
 Center Contacts: 16 oz. Max Insertion.  
 .5 oz. Min. Withdrawal.  
 Housing Retention: 12 lbs. Min.

## ELECTRICAL

Frequency Range: DC to 1000 MHz.  
 Voltage Rating Straight: 1000 V RMS.  
 Voltage Rating Angled: 800 V RMS.  
 Current Rating: 5 Amps.  
 Max. Power: 500 Watts.

Contact Resistance: Center Contact 5 Milliohms.  
 Contact Resistance: Outer Contact 3 Milliohms.  
 Insertion Loss: .5 dB Max.  
 Insulation Resistance: 5000 Megohms Min.  
 DWV: See detailed chart located in Appendix A.

## ENVIRONMENTAL

Operating Temperature Range: -67° F to +257° F.  
 (-55° C to +125° C)  
 Vibration: MIL-STD-1344, Method 2005, Test Condition 4.  
 Shock: MIL-STD-1344, Method 2004, Test Condition E.

Salt Spray: MIL-STD-1344, Method 1001, Condition B.  
 Durability: 500 Cycles.

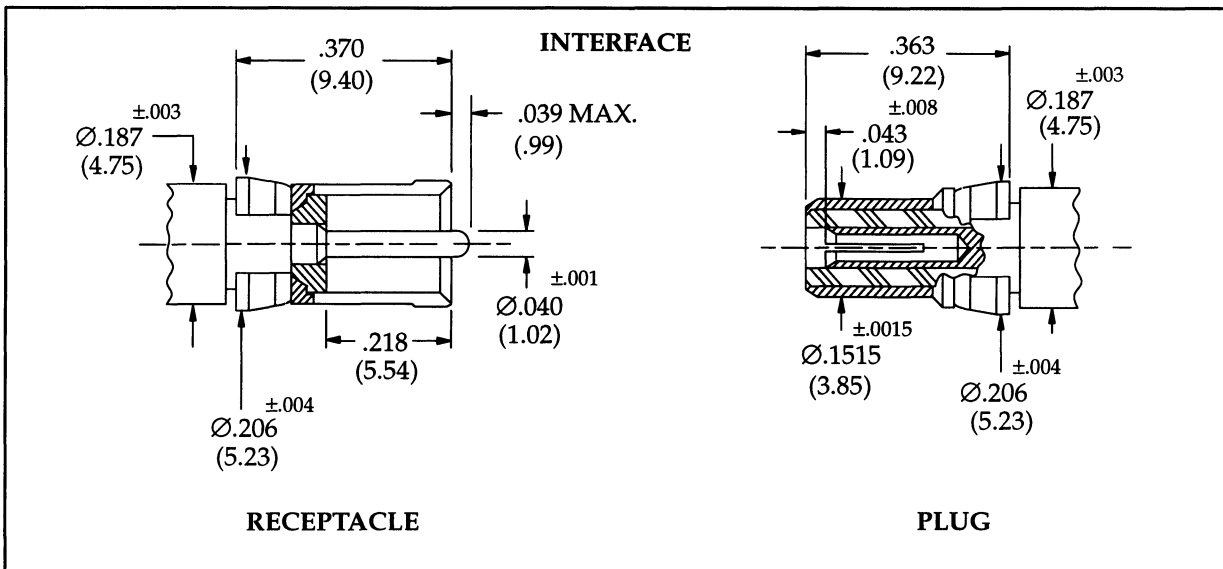

\* All other components plated to meet environmental requirements.  
 \*\*\*"F" Plating may not meet all aspects of Environmental Specifications.



# PDM 15 SERIES SOLDER

Part Number	A MAX.	B REF.	C DIA.	Cable
15-0020-0400*	.739 (18.77)	.929 (23.60)	.040 (1.02)	RG178,196
15-0020-0670*	.739 (18.77)	.929 (23.60)	.067 (1.70)	RG316,188,187,174,179
15-0020-1080*	.847 (21.51)	1.037 (26.34)	.108 (2.74)	RG180,195
15-0020-1201*	.847 (21.51)	1.037 (26.34)	.120 (3.05)	RG58,141,303
15-0020-2201*	.847 (21.51)	1.037 (26.34)	.120 (3.05)	RG400,142
15-0020-2670*	.739 (18.77)	.929 (23.60)	.067 (1.70)	RG316 D.S. (M17/152)

### Straight Plug

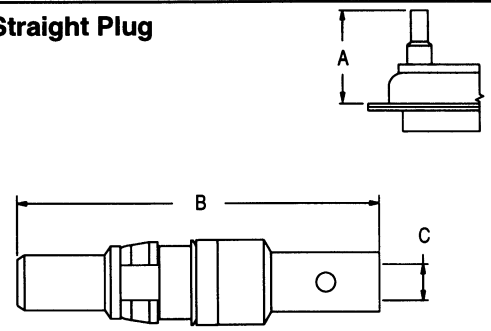

Solder

Part Number	A MAX.	B REF.	C DIA.	Cable
15-1020-0400*	.739 (18.77)	.929 (23.60)	.040 (1.02)	RG178,196
15-1020-0670*	.739 (18.77)	.929 (23.60)	.067 (1.70)	RG316,188,187,174,179
15-1020-1080*	.847 (21.51)	1.037 (26.34)	.108 (2.74)	RG180,195
15-1020-1201*	.847 (21.51)	1.037 (26.34)	.120 (3.05)	RG58,141,303
15-1020-2201*	.847 (21.51)	1.037 (26.34)	.120 (3.05)	RG400,142
15-1020-2670*	.739 (18.77)	.929 (23.60)	.067 (1.70)	RG316 D.S. (M17/152)

### Straight Receptacle

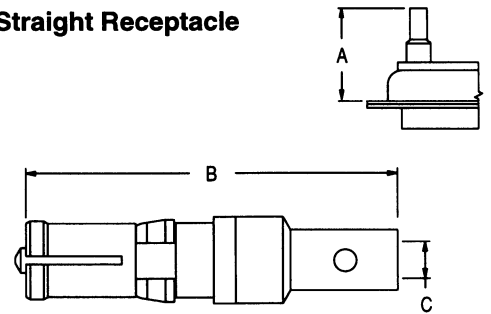

Solder

Part Number	A MAX.	B REF.	C DIA.	D REF.	Cable
15-0520-0400*	.530 (13.46)	.734 (18.64)	.040 (1.02)	.492 (12.50)	RG178,196
15-0520-0670*	.530 (13.46)	.734 (18.64)	.067 (1.70)	.492 (12.50)	RG316,188,187, RG174,179
15-0520-1080*	.530 (13.46)	.734 (18.64)	.108 (2.74)	.606 (15.39)	RG180,195
15-0520-1201*	.530 (13.46)	.734 (18.64)	.120 (3.05)	.606 (15.39)	RG58,141,303
15-0520-2201*	.530 (13.46)	.734 (18.64)	.120 (3.05)	.606 (15.39)	RG400,142
15-0520-2670*	.530 (13.46)	.734 (18.64)	.067 (1.70)	.492 (12.50)	RG316 D.S. (M17/152)

### Right Angle Plug

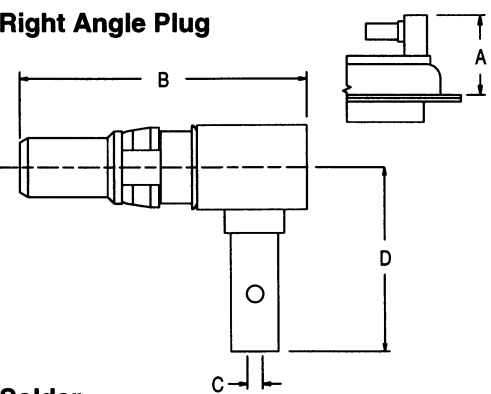

Solder

Part Number	A MAX.	B REF.	C DIA.	D REF.	Cable
15-1520-0400*	.530 (13.46)	.744 (18.90)	.040 (1.02)	.492 (12.50)	RG178,196
15-1520-0670*	.530 (13.46)	.744 (18.90)	.067 (1.70)	.492 (12.50)	RG316,188,187, RG174,179
15-1520-1080*	.530 (13.46)	.744 (18.90)	.108 (2.74)	.606 (15.39)	RG180,195
15-1520-1201*	.530 (13.46)	.744 (18.90)	.120 (3.05)	.606 (15.39)	RG58,141,303
15-1520-2201*	.530 (13.46)	.744 (18.90)	.120 (3.05)	.606 (15.39)	RG400,142
15-1520-2670*	.530 (13.46)	.744 (18.90)	.067 (1.70)	.492 (12.50)	RG316 D.S. (M17/152)

### Right Angle Receptacle

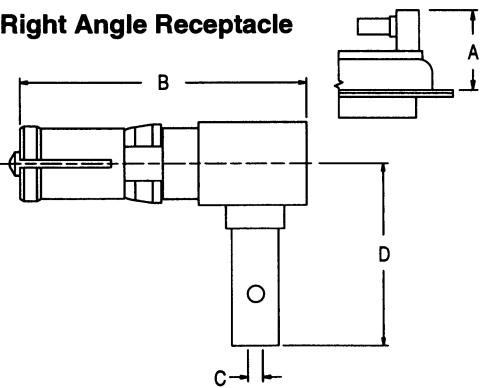

Solder

\*See Specification Page for finish suffix.



**THE PHOENIX COMPANY**  
of CHICAGO, INC.

Dimensions are subject to change without notice.

**PALCO CONNECTOR**

A subsidiary of The Phoenix Company

555 Pond Drive ■ Wood Dale, IL 60191-1192 ■ Toll Free (800)323-9562

# PDM 15 SERIES SEMI-RIGID - SOLDER

Part Number	A MAX.	B REF.	C DIA.	Cable
15-0020-0860*	.62 (15.75)	.86 (21.84)	.092 (2.34)	RG405-M17/133 (.086 S.R.)
15-0020-1410*	.62 (15.75)	.86 (21.84)	.145 (3.68)	RG402-M17/130 (.141 S.R.)

**Straight Plug  
SEMI-RIGID**

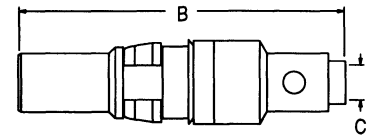
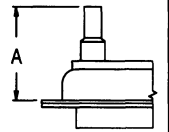

**Solder**

Part Number	A MAX.	B REF.	C DIA.	Cable
15-1020-0860*	.62 (15.75)	.86 (21.84)	.092 (2.34)	RG405-M17/133 (.086 S.R.)
15-1020-1410*	.62 (15.75)	.86 (21.84)	.145 (3.68)	RG402-M17/130 (.141 S.R.)

**Straight Receptacle  
SEMI-RIGID**

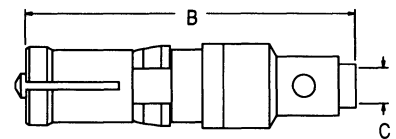
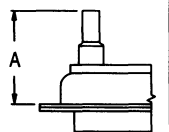

**Solder**

Part Number	A MAX.	B REF.	C DIA.	D REF.	Cable
15-0520-0860*	.530 (13.46)	.74 (18.80)	.092 (2.34)	.37 (9.40)	RG405-M17/133 (.086 S.R.)
15-0520-1410*	.530 (13.46)	.74 (18.80)	.145 (3.68)	.37 (9.40)	RG402-M17/130 (.141 S.R.)

**Right Angle Plug  
SEMI-RIGID**

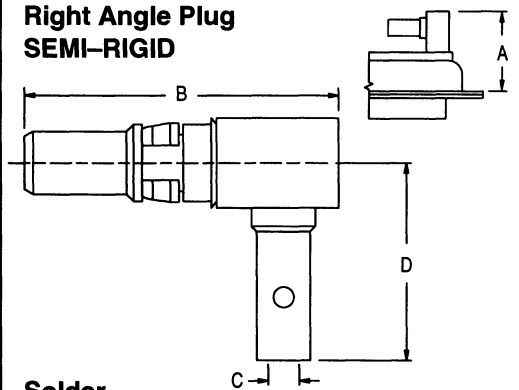

**Solder**

Part Number	A MAX.	B REF.	C DIA.	D REF.	Cable
15-1520-0860*	.530 (13.46)	.74 (18.80)	.092 (2.34)	.37 (9.40)	RG405-M17/133 (.086 S.R.)
15-1520-1410*	.530 (13.46)	.74 (18.80)	.145 (3.68)	.37 (9.40)	RG402-M17/130 (.141 S.R.)

**Right Angle Receptacle  
SEMI-RIGID**

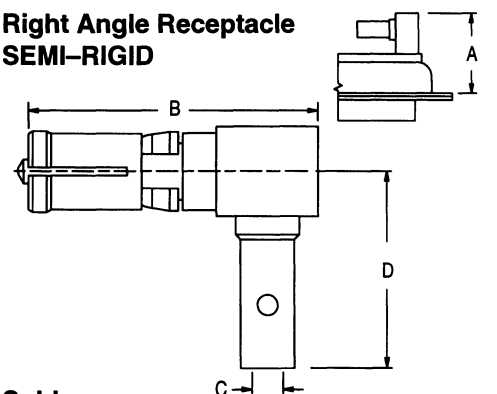

**Solder**

\*See Specification Page for finish suffix.



**THE PHOENIX COMPANY**  
of CHICAGO, INC.

Dimensions are subject to change without notice.

**PALCO CONNECTOR**

A subsidiary of The Phoenix Company

555 Pond Drive • Wood Dale, IL 60191-1192 • Toll Free (800)323-9562

# PDM 15 SERIES CRIMP

Part Number	A MAX.	B REF.	C DIA.	Cable
15-0080-0400*	.739 (18.77)	.929 (23.60)	.040 (1.02)	RG178,196
15-0080-0670*	.739 (18.77)	.929 (23.60)	.067 (1.70)	RG316,188,187,174,179
15-0080-1080*	.847 (21.51)	1.037 (26.34)	.108 (2.74)	RG180,195
15-0080-1201*	.847 (21.51)	1.037 (26.34)	.120 (3.05)	RG58,141,303
15-0080-2201*	.847 (21.51)	1.037 (26.34)	.120 (3.05)	RG400,142
15-0080-2670*	.739 (18.77)	.929 (23.60)	.067 (1.70)	RG316 D.S. (M17/152)

## Straight Plug

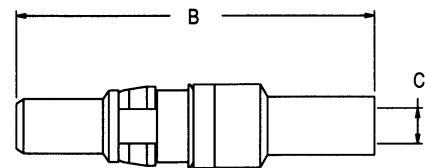
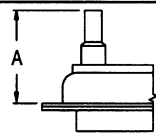

**Crimp** Consult Factory For Tooling Information.

Part Number	A MAX.	B REF.	C DIA.	Cable
15-1080-0400*	.739 (18.77)	.929 (23.60)	.040 (1.02)	RG178,196
15-1080-0670*	.739 (18.77)	.929 (23.60)	.067 (1.70)	RG316,188,187,174,179
15-1080-1080*	.847 (21.51)	1.037 (26.34)	.108 (2.74)	RG180,195
15-1080-1201*	.847 (21.51)	1.037 (26.34)	.120 (3.05)	RG58,141,303
15-1080-2201*	.847 (21.51)	1.037 (26.34)	.120 (3.05)	RG400,142
15-1080-2670*	.739 (18.77)	.929 (23.60)	.067 (1.70)	RG316 D.S. (M17/152)

## Straight Receptacle

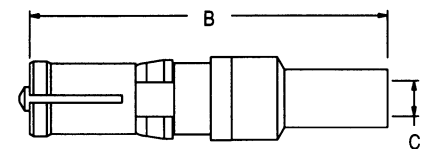
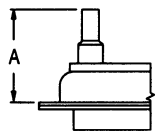

**Crimp** Consult Factory For Tooling Information.

Part Number	A MAX.	B REF.	C DIA.	D REF.	Cable
15-0580-0400*	.530 (13.46)	.734 (18.64)	.040 (1.02)	.492 (12.50)	RG178,196
15-0580-0670*	.530 (13.46)	.734 (18.64)	.067 (1.70)	.492 (12.50)	RG316,188,187, RG174,179
15-0580-1080*	.530 (13.46)	.734 (18.64)	.108 (2.74)	.606 (15.39)	RG180,195
15-0580-1201*	.530 (13.46)	.734 (18.64)	.120 (3.05)	.606 (15.39)	RG58,141,303
15-0580-2201*	.530 (13.46)	.734 (18.64)	.120 (3.05)	.606 (15.39)	RG400,142
15-0580-2670*	.530 (13.46)	.734 (18.64)	.067 (1.70)	.492 (12.50)	RG316 D.S. (M17/152)

## Right Angle Plug

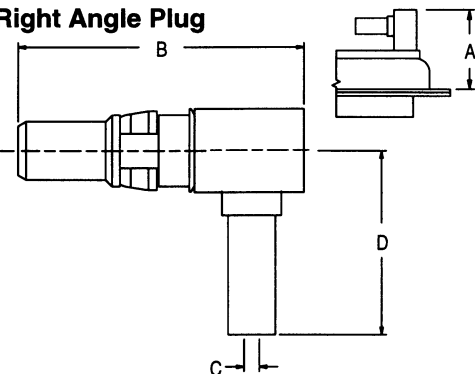

**Crimp** Consult Factory For Tooling Information.

Part Number	A MAX.	B REF.	C DIA.	D REF.	Cable
15-1580-0400*	.530 (13.46)	.744 (18.90)	.040 (1.02)	.492 (12.50)	RG178,196
15-1580-0670*	.530 (13.46)	.744 (18.90)	.067 (1.70)	.492 (12.50)	RG316,188,187, RG174,179
15-1580-1080*	.530 (13.46)	.744 (18.90)	.108 (2.74)	.606 (15.39)	RG180,195
15-1580-1201*	.530 (13.46)	.744 (18.90)	.120 (3.05)	.606 (15.39)	RG58,141,303
15-1580-2201*	.530 (13.46)	.744 (18.90)	.120 (3.05)	.606 (15.39)	RG400,142
15-1580-2670*	.530 (13.46)	.744 (18.90)	.067 (1.70)	.492 (12.50)	RG316 D.S. (M17/152)

## Right Angle Receptacle

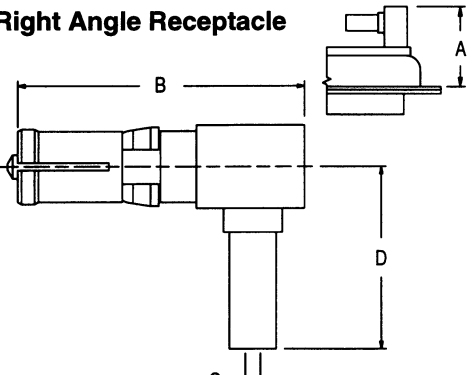

**Crimp** Consult Factory For Tooling Information.

\*See Specification Page for finish suffix.



**THE PHOENIX COMPANY**  
of CHICAGO, INC.

Dimensions are subject to change without notice.

**PALCO CONNECTOR**

A subsidiary of The Phoenix Company

555 Pond Drive • Wood Dale, IL 60191-1192 • Toll Free (800)323-9562

Phoenix double crimp, size 8 contacts are offered in standard, 50 and 75 ohm versions, as solderless, cost effective alternatives for high volume manufacturing needs. The double crimp contact design consists of a one piece body, a separate snap fit, center contact and an outer ferrule. Both center contact and outer ferrule can be terminated with a high speed crimping operation or conventional hand-held tool. Phoenix double crimp contacts are intermateable to "industry standard" equivalent, D-subminiature coaxial contact varieties.

Part Number	Cable	A MAX.
15-0090-0672*	RG188,316	.739 (18.77)

**Straight Plug**

**Double Crimp** Consult Factory For Tooling Information.

Part Number	Cable	A MAX.
15-1090-0672*	RG188,316	.739 (18.77)

**Straight Receptacle**

**Double Crimp** Consult Factory For Tooling Information.

\*See Specification Page for finish suffix.



# PDM 15 SERIES PRINTED CIRCUIT MOUNT

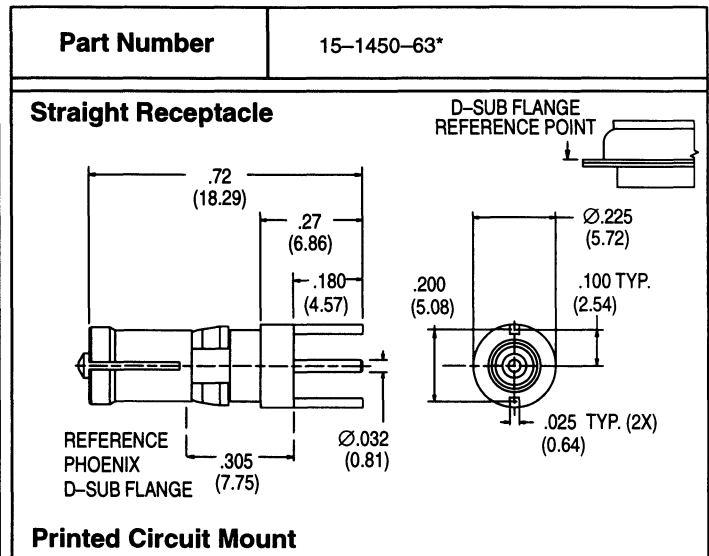
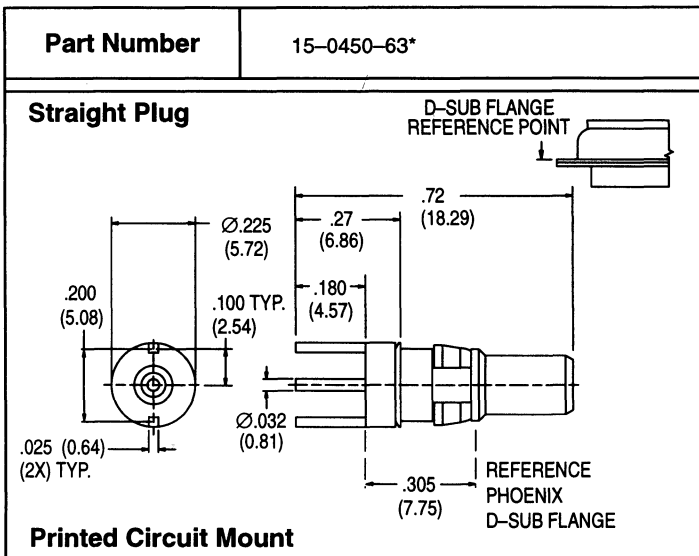

Part Number	A MAX.	B REF.	C	Fits Shell
15-2450-63*	.92 (23.37)	.515 (13.08)	.570 (14.48)	D
15-2450-73*	.82 (20.83)	.400 (10.16)	.470 (11.94)	E,A,B,C
15-2450-83*	.72 (18.29)	.400 (10.16)	.370 (9.40)	E,A,B,C

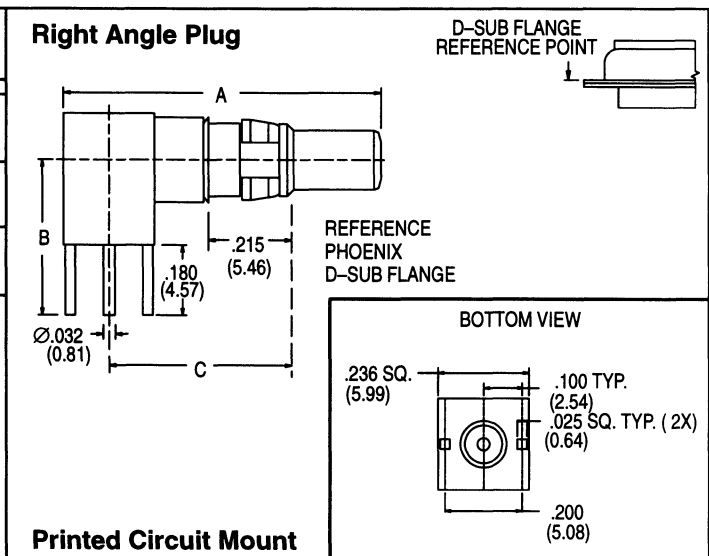

Part Number	A MAX.	B REF.	C	Fits Shell
15-3450-63*	.93 (23.62)	.515 (13.08)	.570 (14.48)	D
15-3450-73*	.83 (21.03)	.400 (10.16)	.470 (11.94)	E,A,B,C
15-3450-83*	.73 (18.54)	.400 (10.16)	.370 (9.40)	E,A,B,C

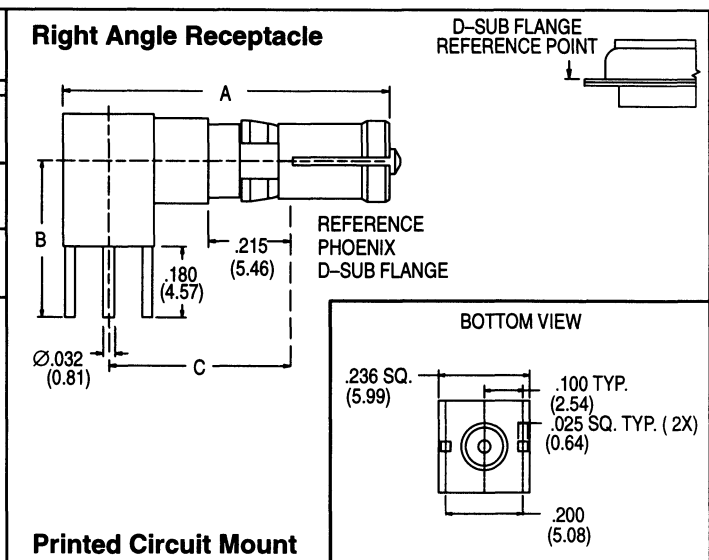

\*See Specification Page for finish suffix.

