

8051 Microcontroller Family Compatible

256K

X88257

32,768 x 8 Bit

E² Micro-Peripheral

FEATURES

- **Multiplexed Address/Data Bus**
 - Direct Interface to Popular 8051 Family
- **High Performance CMOS**
 - Fast Access Time, 120ns
 - Low Power
 - 60mA Active Maximum
 - 500µA Standby Maximum
- **Software Data Protection**
- **Toggle Bit Polling**
 - Early End of Write Detection
- **Page Mode Write**
 - Allows up to 128 Bytes to be Written in One Write Cycle
- **High Reliability**
 - Endurance: 10,000 Write Cycle
 - Data Retention: 100 Years
- **28-Lead PDIP Package**
- **28-Lead SOIC Package**
- **32-Lead PLCC Package**

DESCRIPTION

The X88257 is an 32K x 8 E²PROM fabricated with advanced CMOS Textured Poly Floating Gate Technology. The X88257 features a multiplexed address and data bus allowing direct interface to a variety of popular single-chip microcontrollers operating in expanded multiplexed mode without the need for additional interface circuitry.

FUNCTIONAL DIAGRAM

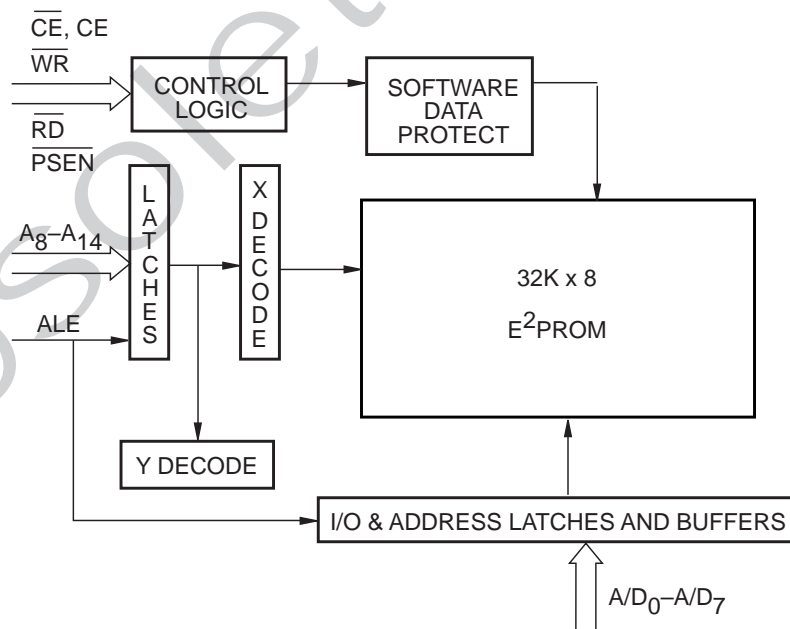

6509 ILL F02.1

X88257

PIN DESCRIPTIONS

Address/Data (A/D₀–A/D₇)

Multiplexed low-order addresses and data. The addresses flow into the device while ALE is HIGH. After ALE transitions from a HIGH to LOW the addresses are latched. Once the addresses are latched these pins input data or output data depending on RD, WR, PSEN, and CE.

Addresses (A₈–A₁₄)

High order addresses flow into the device when ALE = V_{IH} and are latched when ALE goes LOW.

Chip Enable (CE)

The Chip Enable input must be LOW to enable all read/write operations. When CE is HIGH, ALE is LOW, and CE is LOW, the X88257 is placed in the low power standby mode. If CE is used to select the device, the CE must be tied LOW.

Chip Enable (CE)

Chip enable is active HIGH. When CE is used to select the device, the CE must be tied HIGH.

Program Store Enable (PSEN)

When the X88257 is to be used in a 8051-based system, PSEN is tied directly to the microcontroller's PSEN output.

Read (RD)

When the X88257 is to be used in a 8051-based system, RD is tied directly to the microcontroller's RD output.

Write (WR)

When the X88257 is to be used in a 8051-based system, WR is tied directly to the microcontroller's WR output.

Address Latch Enable (ALE)

Addresses flow through the latches to address decoders when ALE is HIGH and are latched when ALE transitions from a HIGH to LOW.

PIN CONFIGURATION

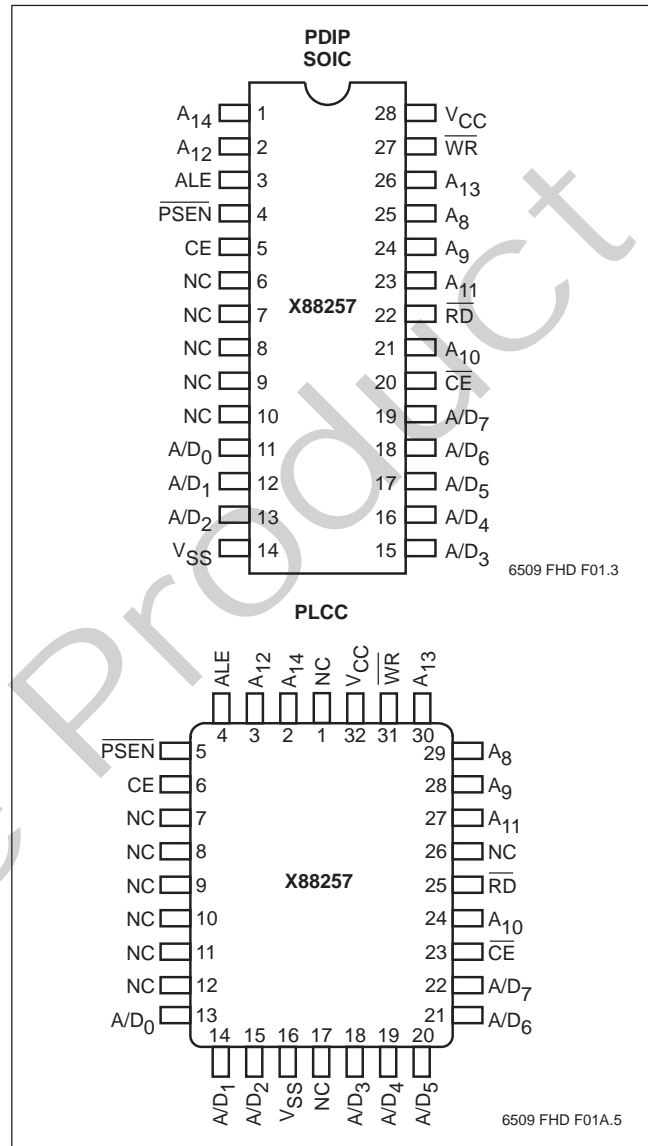

PIN NAMES

Symbol	Description
ALE	Address Latch Enable
A/D ₀ –A/D ₇	Address Inputs/Data I/O
A ₈ –A ₁₄	Address Inputs
RD	Read Input
WR	Write Input
PSEN	Program Store Enable Input
CE, CE	Chip Enable
V _{SS}	Ground
V _{CC}	Supply Voltage
NC	No Connect

X88257

TYPICAL APPLICATION

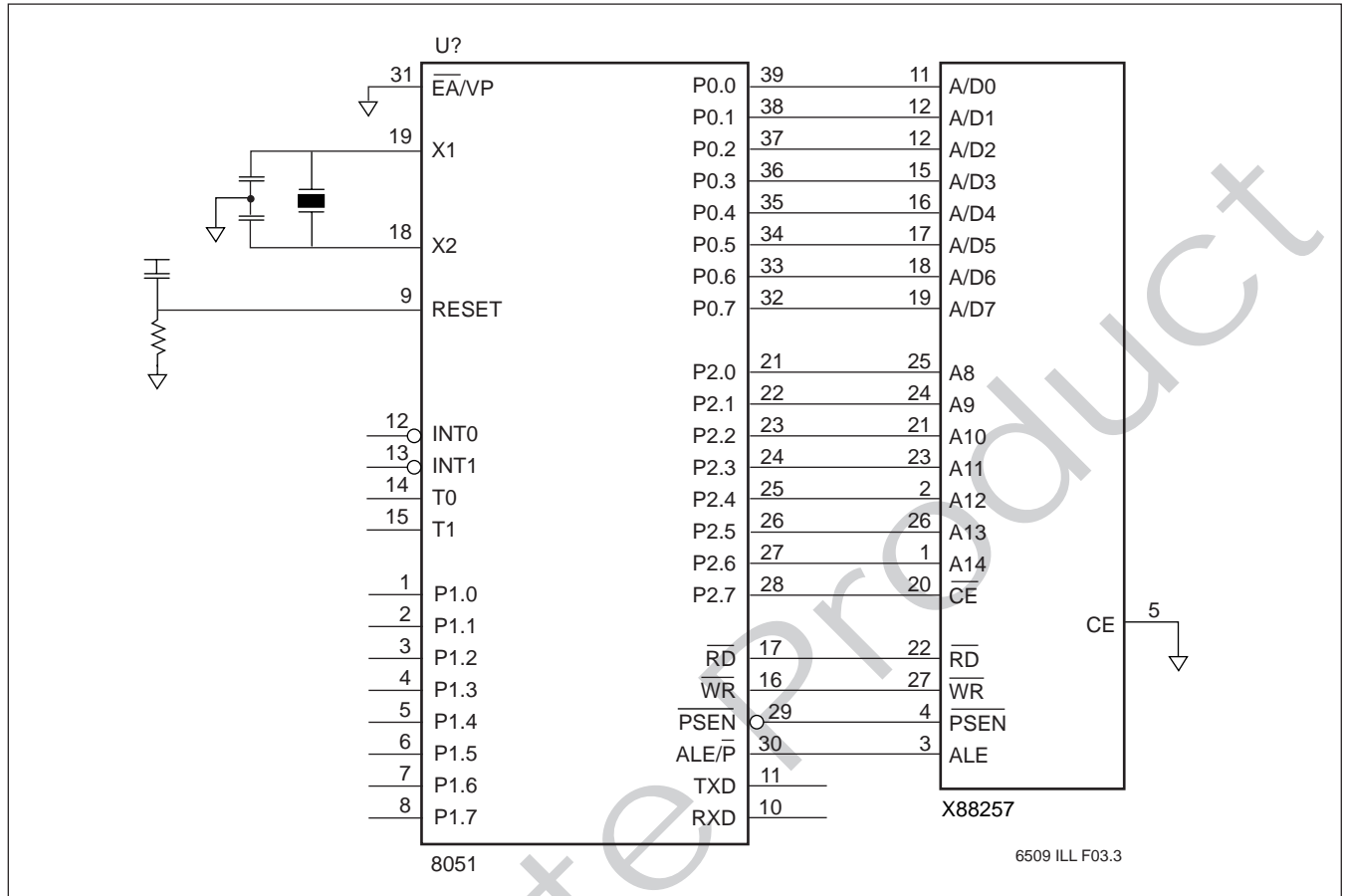

PRINCIPLES OF OPERATION

The X88257 is a highly integrated peripheral device for a wide variety of single-chip microcontrollers. The X88257 provides 32K-bytes of 5V E²PROM which can be used either for program storage, data storage or a combination of both, in systems based upon Harvard (80XX) architectures. The X88257 incorporates the interface circuitry normally needed to decode the control signals and demultiplex the address/data bus to provide a "seamless" interface.

The interface inputs on the X88257 are configured such that it is possible to directly connect them to the proper interface signals of the appropriate single-chip microcontroller. In the Harvard type system, the reading of data from the chip is controlled either by the PSEN or the RD signal, which essentially maps the X88257 into both the Program and the Data Memory address map.

The X88257 also features the industry standard 5V E²PROM characteristics such as byte or page mode write and Toggle Bit Polling.

DEVICE OPERATION

Modes—Mixed Program/Data Memory

By properly assigning the address spaces, a single X88257 can be used as both the program and data memory. This would be accomplished by connecting all the 8051 control outputs to the corresponding inputs of the X88257.

Program Memory Mode

This mode of operation is read-only. The PSEN and ALE inputs of the X88257 are tied directly to the PSEN and ALE outputs of the microcontroller. The RD and WR inputs are tied HIGH.

When ALE is HIGH, the A/D₀–A/D₇ and A₈–A₁₄ addresses flow into the device. The addresses, both low- and high-order, are latched when ALE transitions LOW (V_{IL}). PSEN will then go LOW and after t_{PLDV} ; Valid data is presented on the A/D₀–A/D₇ pins. CE must be LOW during the entire operation.

X88257

DATA MEMORY MODE

This mode of operation allows both read and write functions. The \overline{PSEN} input is tied to V_{IH} or to V_{CC} through a pull-up resistor. The ALE , \overline{RD} , and \overline{WR} inputs are tied directly to the microcontroller ALE , \overline{RD} , and \overline{WR} outputs.

Read

This operation is quite similar to the program memory read. A HIGH to LOW transition on ALE latches the

addresses and the data will be output on the AD pins after \overline{RD} goes LOW (t_{RLDV}).

Write

A write is performed by latching the addresses on the falling edge of ALE . Then \overline{WR} is strobed LOW followed by valid data being presented at the $A/D_0-A/D_7$ pins. The data will be latched into the X88257 on the rising edge of \overline{WR} . To write to the X88257, a three-byte command sequence must precede the byte(s) being written. (See Software Data Protection.)

MODE SELECTION

CE	PSEN	RD	WR	Mode	I/O	Power
V_{CC}	X	X	X	Standby	High Z	Standby (CMOS)
HIGH	X	X	X	Standby	High Z	Standby (TTL)
LOW	LOW	HIGH	HIGH	Read	DOUT	Active
LOW	HIGH	LOW	HIGH	Read	DOUT	Active
LOW	HIGH	HIGH	—	Write	DIN	Active

6509 PGM T02

PAGE WRITE OPERATION

Regardless of the microcontroller employed, the X88257 supports page mode write operations. This allows the microcontroller to write from 1 to 128 bytes of data to the X88257. Each individual write within a page write operation must conform to the byte write timing requirements.

The falling edge of \overline{WR} starts a timer delaying the internal programming cycle $100\mu s$. Therefore, each successive write operation must begin within $100\mu s$ of the last byte written. The following waveforms illustrate the sequence and timing requirements.

Page Write Timing Sequence for \overline{WR} Controlled Operation

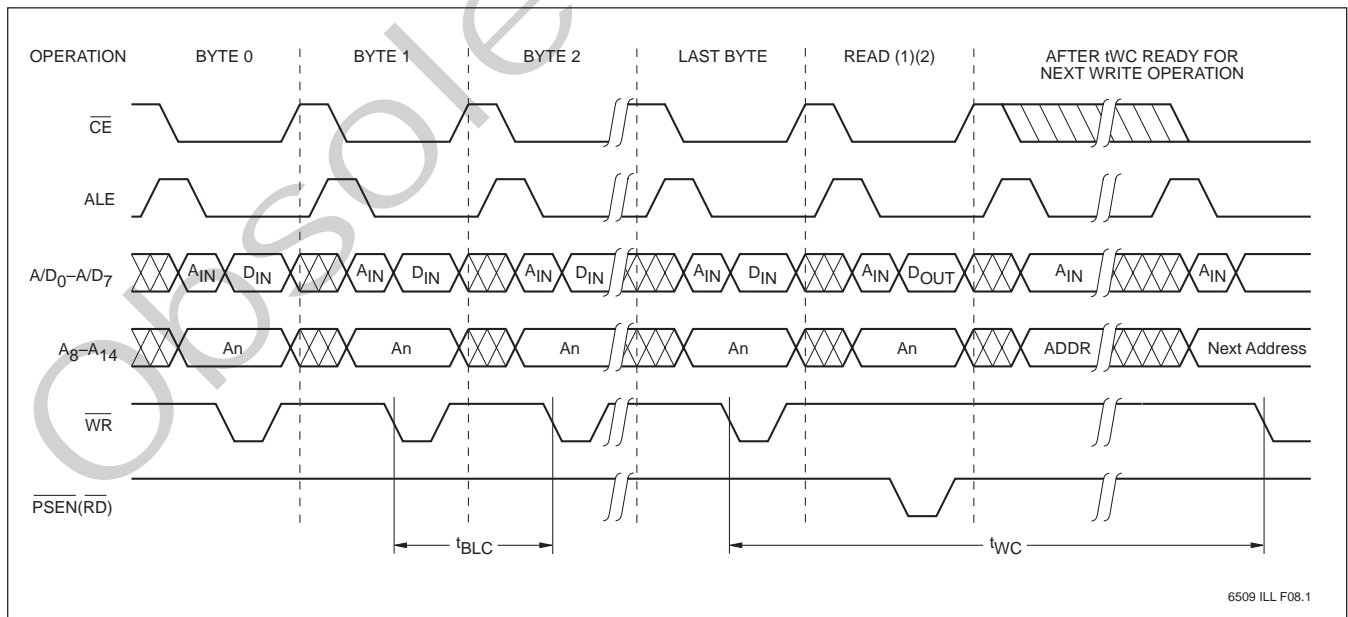

6509 ILL F08.1

Notes: (1) For each successive write within a page write cycle A_7-A_{14} must be the same.

X88257

TOGGLE BIT POLLING

Because the typical write timing is less than the specified 5ms, Toggle Bit Polling has been provided to determine the early end of write. During the internal programming cycle I/O₆ will toggle from “1” to “0” and “0” to “1” on

subsequent attempts to read the device. When the internal cycle is complete the toggling will cease and the device will be accessible for additional read or write operations.

Toggle Bit Polling RD/WR Control

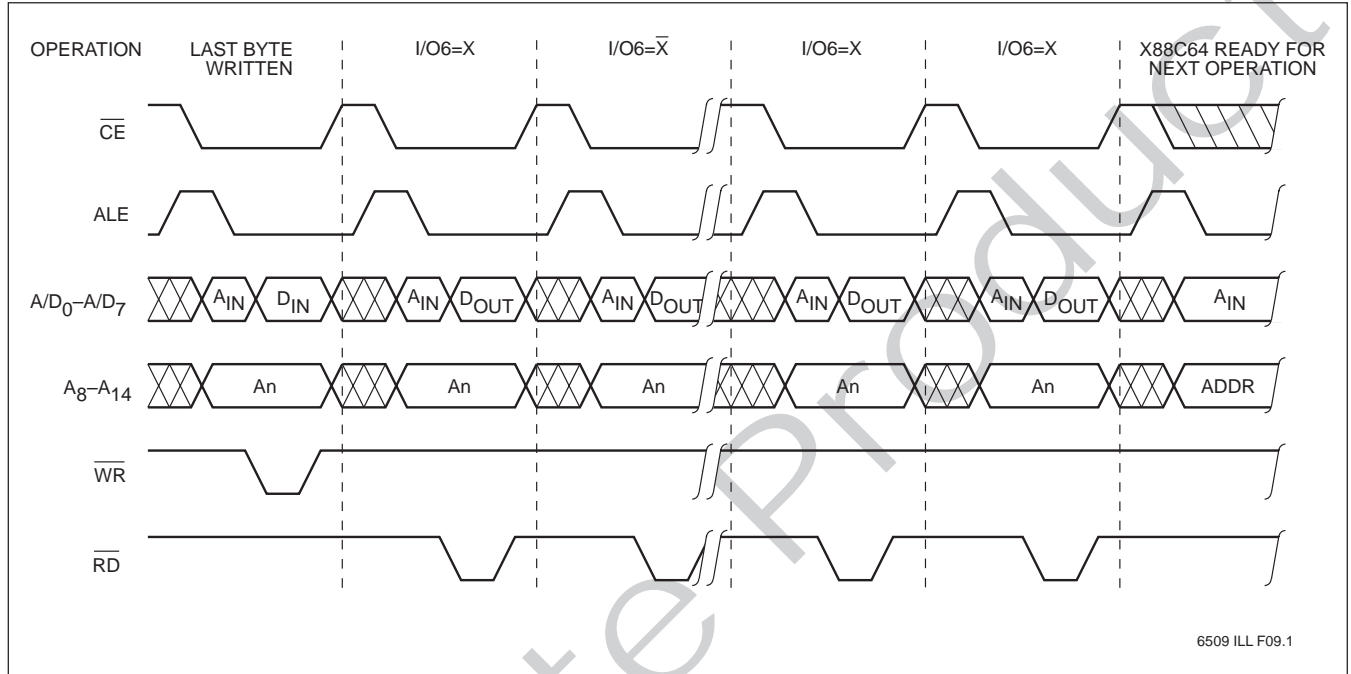

SOFTWARE DATA PROTECTION

Software Data Protection (SDP) is employed to protect the entire array against inadvertent writes. To write to the X88257, a three-byte command sequence must precede the byte(s) being written. All write operations, both the command sequence and any data write operations must conform to the page write timing requirements.

Writing with SDP

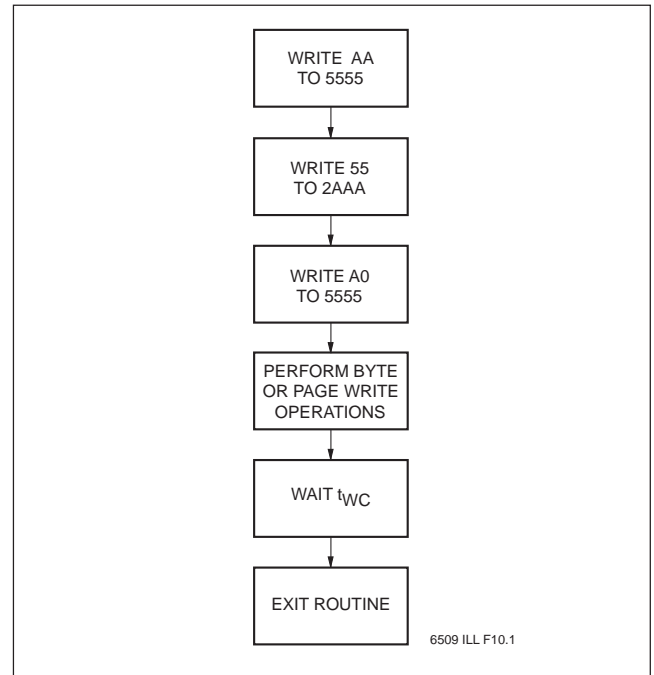

X88257

ABSOLUTE MAXIMUM RATINGS*

Temperature under Bias	-65°C to +135°C
Storage Temperature	-65°C to +150°C
Voltage on any Pin with Respect to V _{SS}	-1V to +7V
D.C. Output Current	5mA
Lead Temperature (Soldering, 10 seconds)	300°C

*COMMENT

Stresses above those listed under “Absolute Maximum Ratings” may cause permanent damage to the device. This is a stress rating only and the functional operation of the device at these or any other conditions above those indicated in the operational sections of this specification is not implied. Exposure to absolute maximum rating conditions for extended periods may affect device reliability.

RECOMMENDED OPERATING CONDITIONS

Temperature	Min.	Max.
Commercial	0°C	+70°C
Industrial	-40°C	+85°C
Military	-55°C	+125°C

Supply Voltage	Limits
X88257	5V ±10%

6509 PGM T04.1

6509 PGM T03.1

D.C. OPERATING CHARACTERISTICS (Over recommended operating conditions unless otherwise specified.)

Symbol	Parameter	Limits		Units	Test Conditions
		Min.	Max.		
I _{CC}	V _{CC} Current (Active)		60	mA	C _E = R _D = V _{IL} , All I/O's = Open, Other Inputs = V _{CC}
I _{SB1} (CMOS)	V _{CC} Current (Standby)		500	µA	C _E = V _{CC} - 0.3V, All I/O's = Open, Other Inputs = V _{CC} - 0.3V, ALE = V _{IL}
I _{SB2} (TTL)	V _{CC} Current (Standby)		6	mA	C _E = V _{IH} , All I/O's = Open, Other Inputs = V _{IH} , ALE = V _{IL}
I _{LI}	Input Leakage Current		10	µA	V _{IN} = V _{SS} to V _{CC}
I _{LO}	Output Leakage Current		10	µA	V _{OUT} = V _{SS} to V _{CC} , R _D = V _{IH} = P _{SEN}
V _{IL} (3)	Input LOW Voltage	-1	0.8	V	
V _{IH} (3)	Input HIGH Voltage	2	V _{CC} + 0.5	V	
V _{OL}	Output LOW Voltage		0.4	V	I _{OL} = 2.1mA
V _{OH}	Output HIGH Voltage	2.4		V	I _{OH} = -400µA

6509 PGM T05.1

CAPACITANCE T_A = +25°C, f = 1MHz, V_{CC} = 5V

Symbol	Test	Max.	Units	Conditions
C _{I/O} (4)	Input/Output Capacitance	10	pF	V _{I/O} = 0V
C _{IN} (4)	Input Capacitance	6	pF	V _{IN} = 0V

6509 PGM T06

POWER-UP TIMING

Symbol	Parameter	Max.	Units
t _{PUR} (4)	Power-Up to Read	1	ms
t _{PUW} (4)	Power-Up to Write	5	ms

6509 PGM T07

Notes: (3) V_{IL} min. and V_{IH} max. are for reference only and are not tested.
(4) This parameter is periodically sampled and not 100% tested.

X88257

A.C. CONDITIONS OF TEST

Input Pulse Levels	0V to 3V
Input Rise and Fall Times	10ns
Input and Output Timing Levels	1.5V

6509 PGM T08.1

EQUIVALENT A.C. TEST CIRCUIT

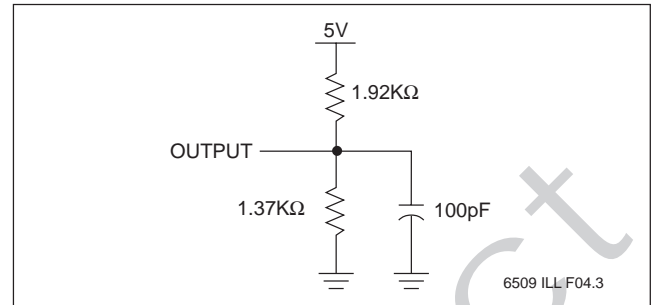

A.C. CHARACTERISTICS (Over the recommended operating conditions unless otherwise specified.)

PSEN Controlled Read Cycle

Symbol	Parameter	Min.	Max.	Units
t_{LHLL}	ALE Pulse Width	80		ns
t_{AVLL}	Address Setup Time	20		ns
t_{LLAX}	Address Hold Time	30		ns
t_{PLDV}	PSEN Read Access Time		120	ns
t_{PHDX}	Data Hold Time	0		ns
t_{ELL}	Chip Enable Setup Time	7		ns
PW _{PL}	PSEN Pulse Width	150		ns
t_{PS}	PSEN Setup Time	30		ns
t_{PH}	PSEN Hold Time	20		ns
$t_{PHDZ}^{(5)}$	PSEN Disable to Output in High Z		50	ns
$t_{PLDX}^{(5)}$	PSEN to Output in Low Z	10		ns

6509 PGM T09

PSEN Controlled Read Timing Diagram

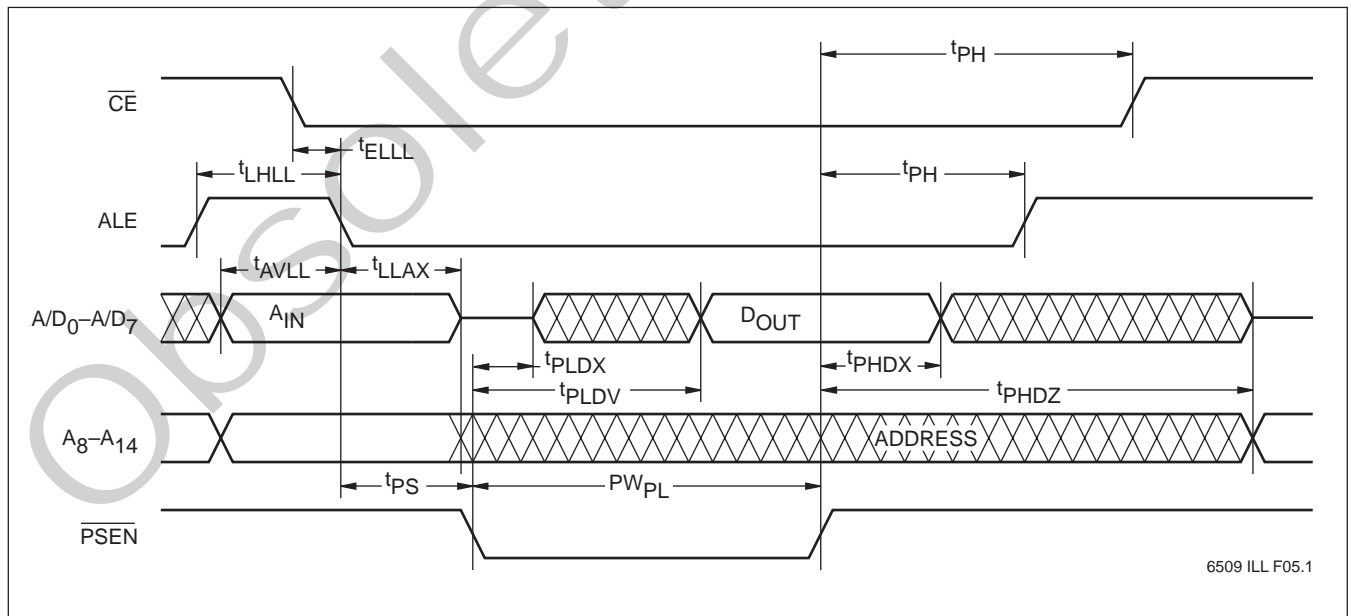

Note: (5) This parameter is periodically sampled and not 100% tested.

X88257

RD Controlled Read Cycle

Symbol	Parameter	Min.	Max.	Units
t_{LHLL}	ALE Pulse Width	80		ns
t_{AVLL}	Address Setup Time	20		ns
t_{LLAX}	Address Hold Time	30		ns
t_{RLDV}	RD Read Access Time		120	ns
t_{RHDX}	Data Hold Time	0		ns
t_{ELLL}	Chip Enable Setup Time	7		ns
PW_{RL}	RD Pulse Width	150		ns
t_{RDS}	RD Setup Time	30		ns
t_{RDH}	RD Hold Time	20		ns
$t_{RHDZ}^{(6)}$	RD Disable to Output in High Z		50	ns
$t_{RLDX}^{(6)}$	RD to Output in Low Z	0		ns

6509 PGM T10

RD Controlled Read Timing Diagram

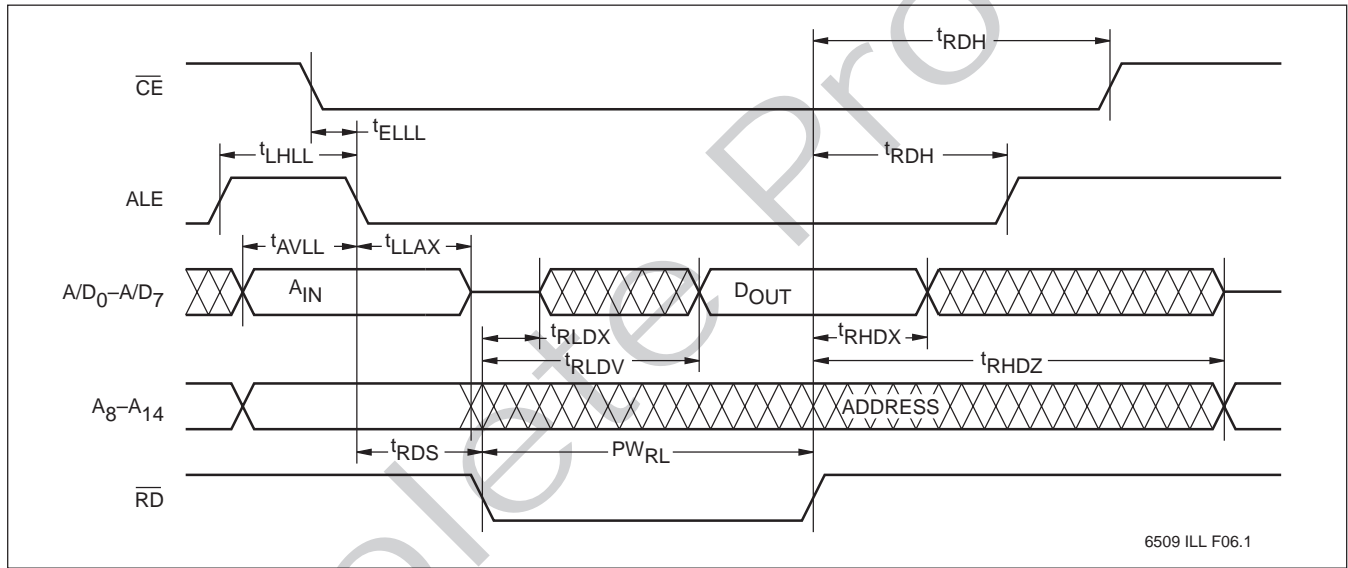

6509 ILL F06.1

Note: (6) This parameter is periodically sampled and not 100% tested.

SYMBOL TABLE

WAVEFORM	INPUTS	OUTPUTS
	Must be steady	Will be steady
	May change from LOW to HIGH	Will change from LOW to HIGH
	May change from HIGH to LOW	Will change from HIGH to LOW
	Don't Care: Changes Allowed	Changing: State Not Known
	N/A	Center Line is High Impedance

X88257

WR Controlled Write Cycle

Symbol	Parameter	Min.	Max.	Units
t_{LHLL}	ALE Pulse Width	80		ns
t_{AVLL}	Address Setup Time	20		ns
t_{LLAX}	Address Hold Time	30		ns
t_{DVWH}	Data Setup Time	50		ns
t_{WHDX}	Data Hold Time	30		ns
t_{ELLL}	Chip Enable Setup Time	7		ns
t_{WLWH}	WR Pulse Width	120		ns
t_{WRS}	WR Setup Time	30		ns
t_{WRH}	WR Hold Time	20		ns
t_{BLC}	Byte Load Time (Page Write)	0.5	100	μ s
$t_{WC}^{(7)}$	Write Cycle Time		5	ms

6509 PGM T11

WR Controlled Write Timing Diagram

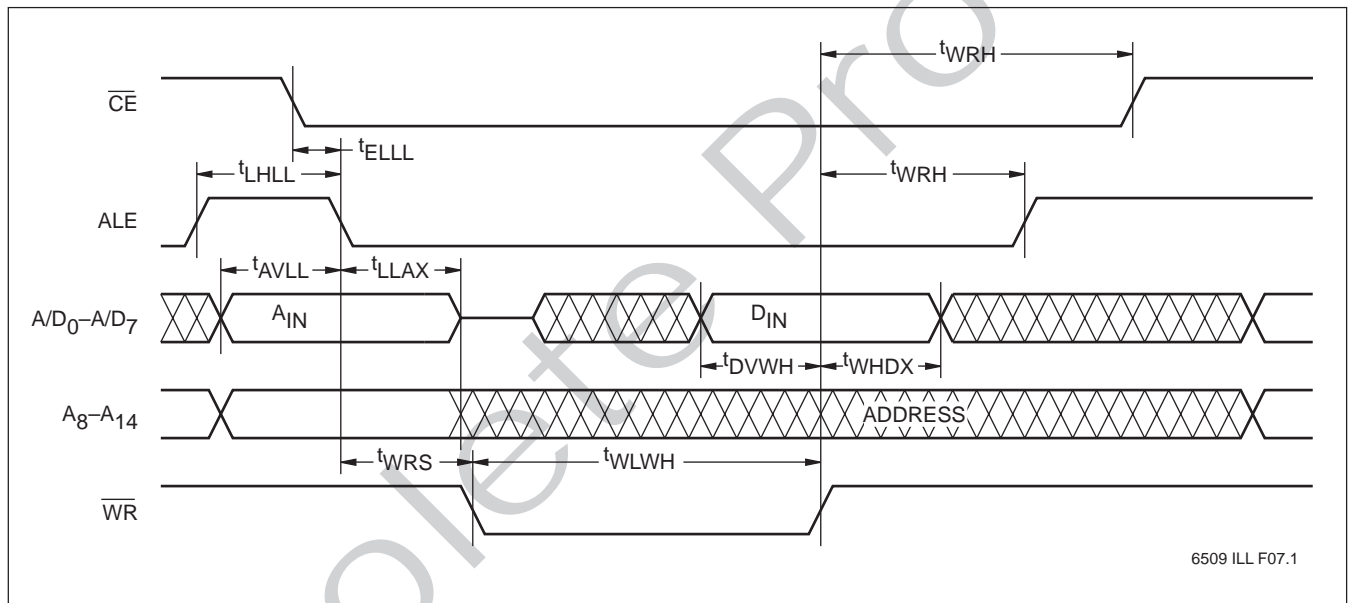

6509 ILL F07.1

Note: (7) t_{WC} is the minimum cycle time to be allowed from the system perspective unless polling techniques are used. It is the maximum time the device requires to automatically complete the internal write operation.

X88257

PACKAGING INFORMATION

28-LEAD PLASTIC DUAL IN-LINE PACKAGE TYPE P

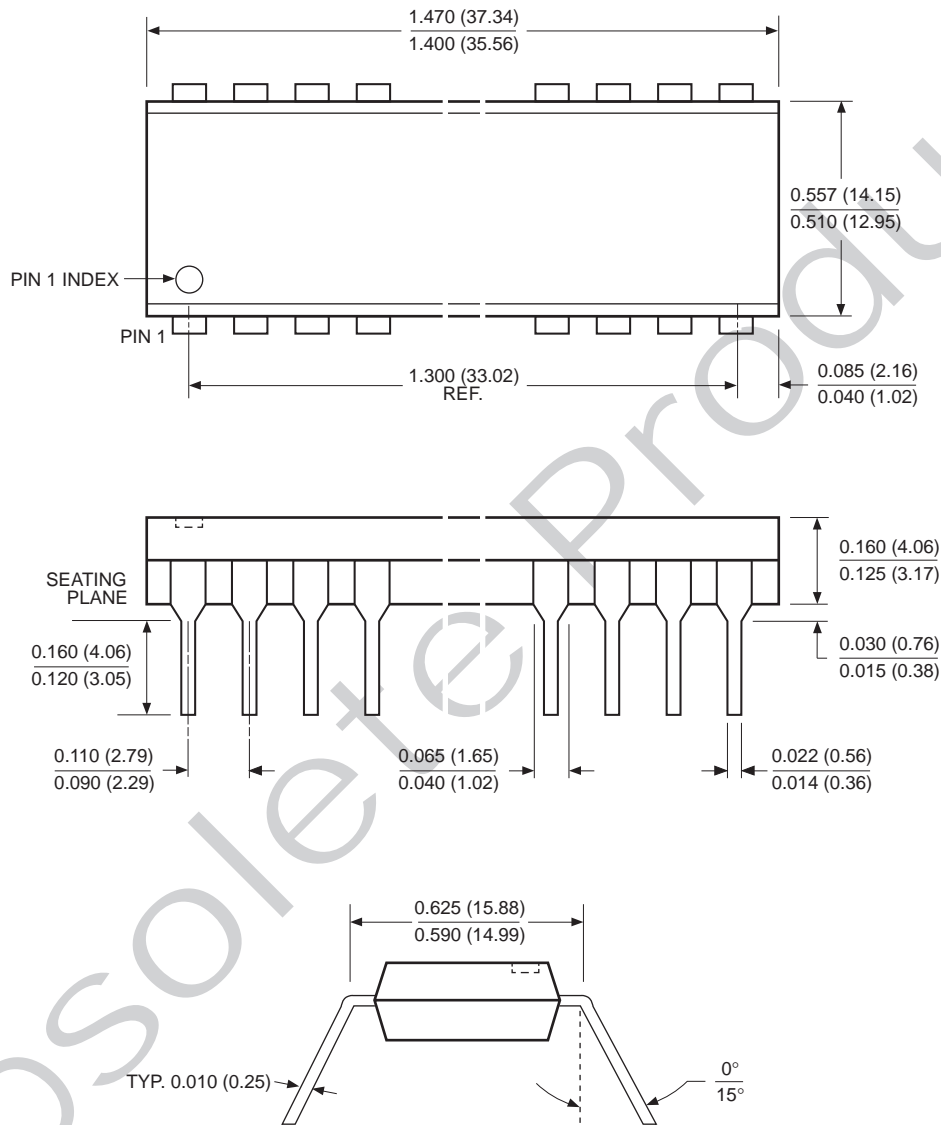

NOTE:

1. ALL DIMENSIONS IN INCHES (IN PARENTHESES IN MILLIMETERS)
2. PACKAGE DIMENSIONS EXCLUDE MOLDING FLASH

3926 FHD F04

PACKAGING INFORMATION

28-LEAD PLASTIC SMALL OUTLINE GULL WING PACKAGE TYPE S

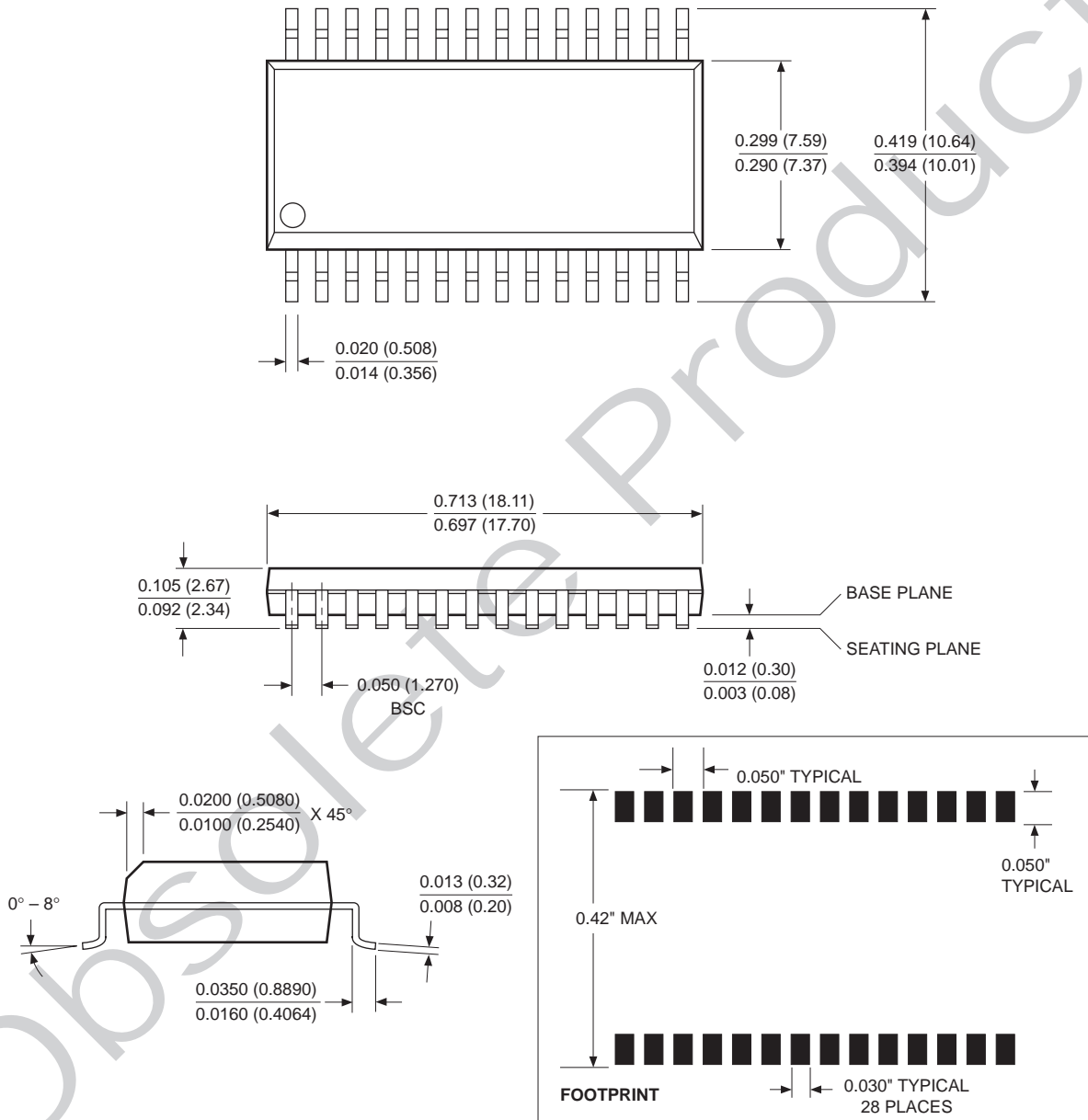

- NOTES:**
1. ALL DIMENSIONS IN INCHES (IN PARENTHESES IN MILLIMETERS)
 2. FORMED LEAD SHALL BE PLANAR WITH RESPECT TO ONE ANOTHER WITHIN 0.004 INCHES

PACKAGING INFORMATION

32-LEAD PLASTIC LEADED CHIP CARRIER PACKAGE TYPE J

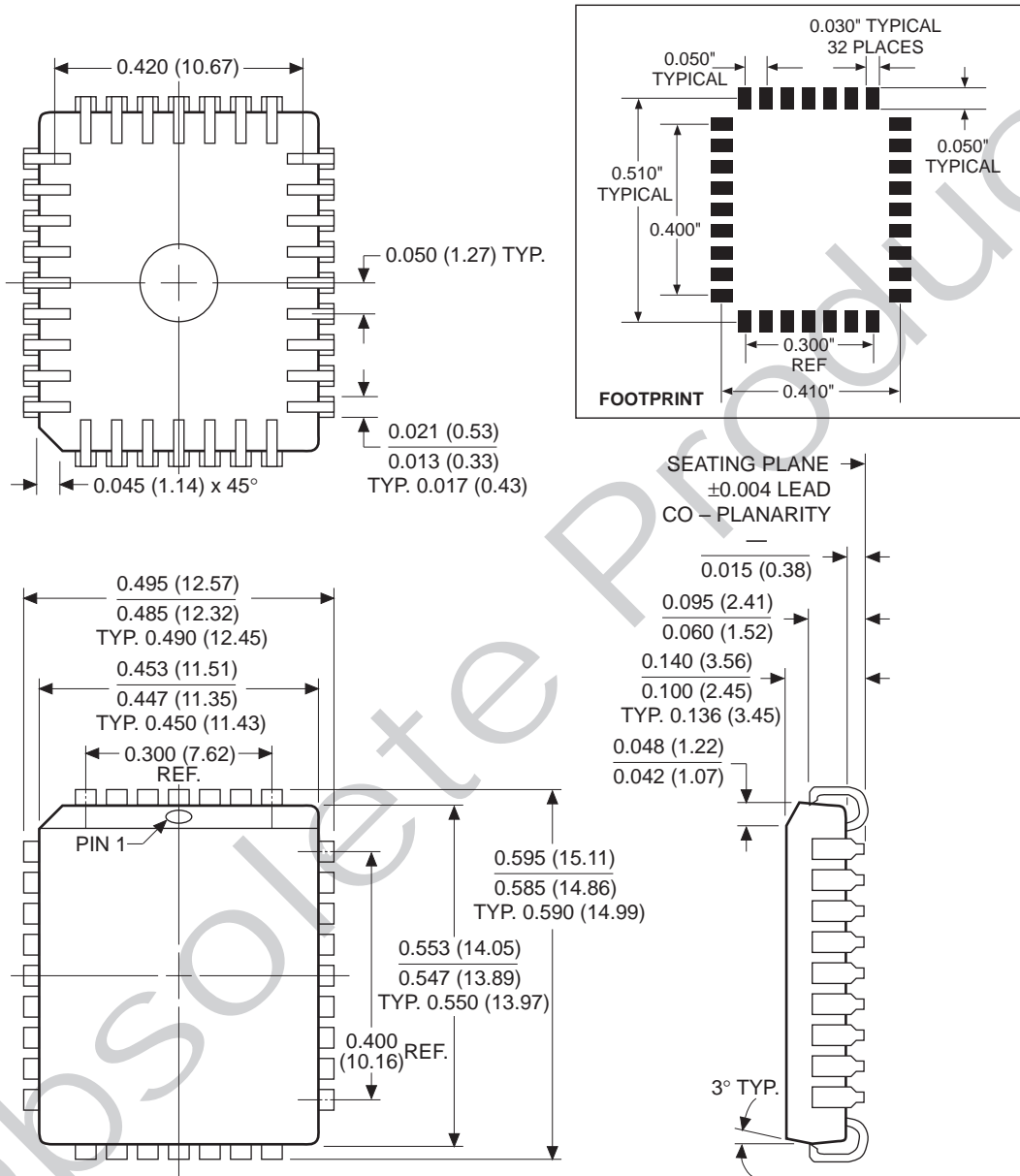

- NOTES:
1. ALL DIMENSIONS IN INCHES (IN PARENTHESES IN MILLIMETERS)
 2. DIMENSIONS WITH NO TOLERANCE FOR REFERENCE ONLY

X88257

ORDERING INFORMATION

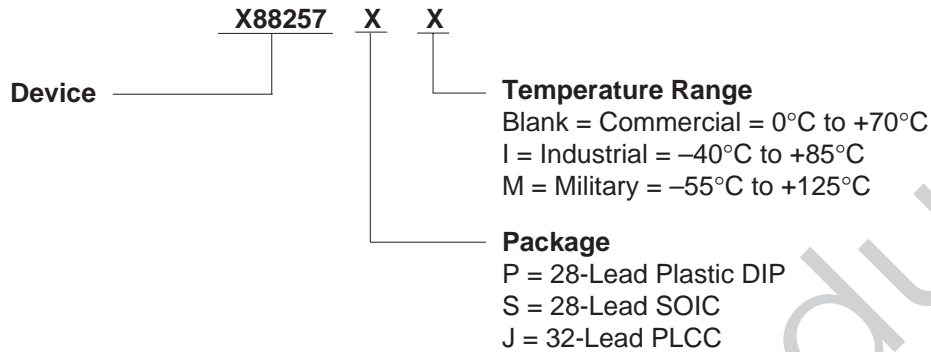

LIMITED WARRANTY

Devices sold by Xicor, Inc. are covered by the warranty and patent indemnification provisions appearing in its Terms of Sale only. Xicor, Inc. makes no warranty, express, statutory, implied, or by description regarding the information set forth herein or regarding the freedom of the described devices from patent infringement. Xicor, Inc. makes no warranty of merchantability or fitness for any purpose. Xicor, Inc. reserves the right to discontinue production and change specifications and prices at any time and without notice.

Xicor, Inc. assumes no responsibility for the use of any circuitry other than circuitry embodied in a Xicor, Inc. product. No other circuits, patents, licenses are implied.

US. PATENTS

Xicor products are covered by one or more of the following U.S. Patents: 4,263,664; 4,274,012; 4,300,212; 4,314,265; 4,326,134; 4,393,481; 4,404,475; 4,450,402; 4,486,769; 4,488,060; 4,520,461; 4,533,846; 4,599,706; 4,617,652; 4,668,932; 4,752,912; 4,829,482; 4,874,967; 4,883,976; 4,980,859; 5,012,132; 5,003,197; 5,023,694. Foreign patents and additional patents pending.

LIFE RELATED POLICY

In situations where semiconductor component failure may endanger life, system designers using this product should design the system with appropriate error detection and correction, redundancy and back-up features to prevent such an occurrence.

Xicor's products are not authorized for use as critical components in life support devices or systems.

1. Life support devices or systems are devices or systems which, (a) are intended for surgical implant into the body, or (b) support or sustain life, and whose failure to perform, when properly used in accordance with instructions for use provided in the labeling, can be reasonably expected to result in a significant injury to the user.
2. A critical component is any component of a life support device or system whose failure to perform can be reasonably expected to cause the failure of the life support device or system, or to affect its safety or effectiveness.