

Features

- Internally frequency compensated for unity gain
- Large dc voltage gain - 100dB
- Wide bandwidth (unity gain) - 1 MHz (temperature compensated)
- Wide power supply range:
Single supply - 3VDC to 30VDC
or dual supplies - ± 1.5 VDC to ± 15 VDC
- Very low supply current drain (500 μ A)
- essentially independent of supply voltage (1mW/op amp at +5VDC)
- Low input biasing current - 45nADC (temperature compensated)
- Low input offset voltage - 2mVDC and offset current - 5nADC
- Input common-mode voltage range includes ground
- Differential input voltage range equal to the power supply voltage
- Large output voltage swing - 0VDC to $V^+ - 1.5$ VDC

ECG928 and ECG928M consists of two independent, high gain, internally frequency compensated operational amplifiers which were designed specifically to operate from a single power supply over a wide range of voltages. Operation from split power supplies is also possible and the low power supply current drain is independent of the magnitude of the power supply voltage.

Application areas include transducer amplifiers, dc gain blocks and all the conventional op amp circuits which now can be more easily implemented in single power supply systems. For example, they can be directly operated off of the standard +5VDC power supply voltage which is used in digital systems and will easily provide the required interface electronics without requiring the additional ± 15 VDC power supplies.

ECG928

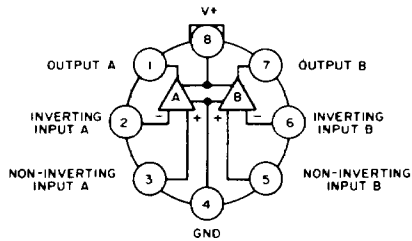
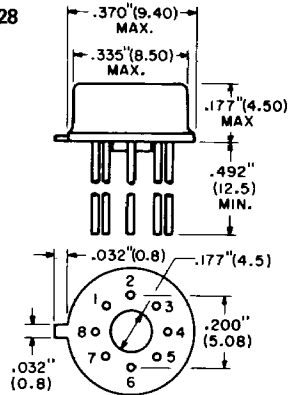

ECG928M

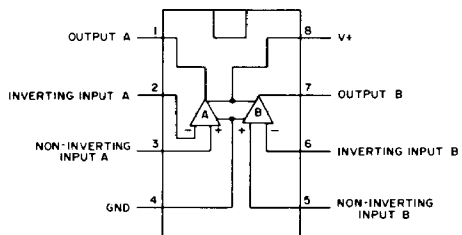
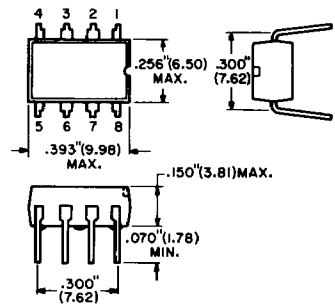

Unique Characteristics

- In the linear mode the input common-mode voltage range includes ground and the output voltage can also swing to ground, even though operated from only a single power supply voltage.
- The unity gain cross frequency is temperature compensated.
- The input bias current is also temperature compensated.

Advantages

- Eliminates need for dual supplies.
- Two internally compensated op amps in a single package.
- Allows directly sensing near GND and V_{OUT} also goes to GND.
- Compatible with all forms of logic.
- Power drain suitable for battery operation.

Electrical Characteristics (V⁺ = +5.0V_{DC}, Note 4)

Parameter	Conditions	Min	Typ	Max	Units
Input Offset Voltage	T _A = 25°C (Note 5)		±2	±7	mV _{DC}
Input Bias Current	I _I (+) or I _I (-), T _A = 25°C (Note 6)		45	250	nA _{DC}
Input Offset Current	I _I (+) - I _I (-), T _A = 25°C		±5	±50	nA _{DC}
Input Common-Mode Voltage Range	V ⁺ = 30V _{DC} , T _A = 25°C (Note 7)	0		V ⁺ - 1.5	V _{DC}
Supply Current	R _L = ∞, V _{CC} = 30V R _L = ∞ On All Op Amps Over Full Temperature Range		1 0.7	2 1.2	mA _{DC} mA _{DC}
Large Signal Voltage Gain	V ⁺ = 15V _{DC} (For Large V _O Swing) R _L ≥ 2kΩ, T _A = 25°C	25	100		V/mV
Output Voltage Swing	R _L = 2kΩ, T _A = 25°C	0		V ⁺ - 1.5	V _{DC}
Common-Mode Rejection Ratio	DC, T _A = 25°C	65	70		dB
Power Supply Rejection Ratio	DC, T _A = 25°C	65	100		dB
Amplifier-to-Amplifier Coupling	f = 1kHz to 20kHz, T _A = 25°C (Input Referred,.) (Note 8)		-120		dB
Output Current Source	V _I N ⁺ = 1V, V _I N ⁻ = 0V _{DC} , V ⁺ = 15V _{DC} , T _A = 25°C	20	40		mA _{DC}
Sink	V _I N ⁻ = 1V _{DC} , V _I N ⁺ = 0V _{DC} , V ⁺ = 15V _{DC} , T _A = 25°C V _I N ⁻ = 1V _{DC} , V _I N ⁺ = 0V _{DC} , T _A = 25°C, V _O = 200mV _{DC}	10 12	20 50		mA _{DC} μA _{DC}
Short Circuit to Ground	T _A = 25°C (Note 2)		40	60	mA _{DC}
Input Offset Voltage	(Note 5)			±9	mV _{DC}
Input Offset Voltage Drift	R _S = 0Ω		7		μV/°C
Input Offset Current	I _I (+) - I _I (-)			±150	nA _{DC}
Input Offset Current Drift			10		pA _{DC} /°C
Input Bias Current	I _I (+) or I _I (-)		40	500	nA _{DC}
Input Common-Mode Voltage Range	V ⁺ = 30V _{DC} (Note 7)	0		V ⁺ - 2	V _{DC}
Large Signal Voltage Gain	V ⁺ = +15V _{DC} (For Large V _O Swing) R _L ≥ 2kΩ	15			V/mV
Output Voltage Swing					
V _{OH}	V ⁺ = +30V _{DC} , R _L = 2kΩ	26			V _{DC}
V _L	R _L ≥ 10kΩ V ⁺ = 5V _{DC} , R _L ≤ 10kΩ	27 5	28 5	20	V _{DC} mV _{DC}
Output Current Source	V _I N ⁺ = +1V _{DC} , V _I N ⁻ = 0V _{DC} , V ⁺ = 15V _{DC}	10	20		mA _{DC}
Sink	V _I N ⁻ = +1V _{DC} , V _I N ⁺ = 0V _{DC} , V ⁺ = 15V _{DC}	5	8		mA _{DC}
Differential Input Voltage	(Note 7)			V ⁺	V _{DC}

Note 1: For operating at high temperatures, they must be derated based on a +125°C maximum junction temperature and a thermal resistance of 175°C/W which applies for the device soldered in a printed circuit board, operating in a still air ambient. The dissipation is the total of all four amplifiers—use external resistors, where possible, to allow the amplifier to saturate or to reduce the power which is dissipated in the integrated circuit.

Note 2: Short circuits from the output to V^+ can cause excessive heating and eventual destruction. The maximum output current is approximately 40mA independent of the magnitude of V^+ . At values of supply voltage in excess of +15VDC, continuous short-circuits can exceed the power dissipation ratings and cause eventual destruction. Destructive dissipation can result from simultaneous shorts on all amplifiers.

Note 3: This input current will only exist when the voltage at any of the input leads is driven negative. It is due to the collector-base junction of the input PNP transistors becoming forward biased and thereby acting as input diode clamps. In addition to this diode action, there is also lateral NPN parasitic transistor action on the IC chip. This transistor action can cause the output voltages of the op amps to go to the V^+ voltage level (or to ground for a large overdrive) for the time duration that an input is driven negative. This is not destructive and normal output states will re-establish when the input voltage, which was negative, again returns to a value greater than $-0.3VDC$.

Note 4: These specifications apply for $V^+ = +5VDC$ and $-55^{\circ}C \leq T_A \leq +125^{\circ}C$, unless otherwise stated. The temperature specifications are limited to $0^{\circ}C \leq T_A \leq +70^{\circ}C$.

Note 5: $V_O = 1.4VDC$, $R_S = 0\Omega$ with V^+ from 5VDC to 30VDC; and over the full input common-mode range (0VDC to $V^+ - 1.5VDC$).

Note 6: The direction of the input current is out of the IC due to the PNP input stage. This current is essentially constant, independent of the state of the output so no loading change exists on the input lines.

Note 7: The input common-mode voltage or either input signal voltage should not be allowed to go negative by more than 0.3V. The upper end of the common-mode voltage range is $V^+ - 1.5V$, but either or both inputs can go to +32VDC without damage.

Note 8: Due to proximity of external components, insure that coupling is not originating via stray capacitance between these external parts. This typically can be detected as this type of capacitive increases at higher frequencies.

Absolute Maximum Ratings

Supply Voltage, V^+	32VDC or $\pm 16VDC$
Differential Input Voltage	32VDC
Input Voltage	$-0.3VDC$ to +32VDC
Power Dissipation (Note 1)	
ECG928M	570mW
ECG928	830mW
Output Short-Circuit to GND (One Amplifier) (Note 2)	Continuous
$V^+ \leq 15VDC$ and $T_A = 25^{\circ}C$	
Input Current ($V_{IN} < -0.3VDC$) (Note 3)	50mA
Operating Temperature Range	0° to $+70^{\circ}C$
Storage Temperature Range	$-65^{\circ}C$ to $+150^{\circ}C$
Lead Temperature (Soldering, 10 seconds)	$300^{\circ}C$

Schematic Diagram (Each Amplifier)

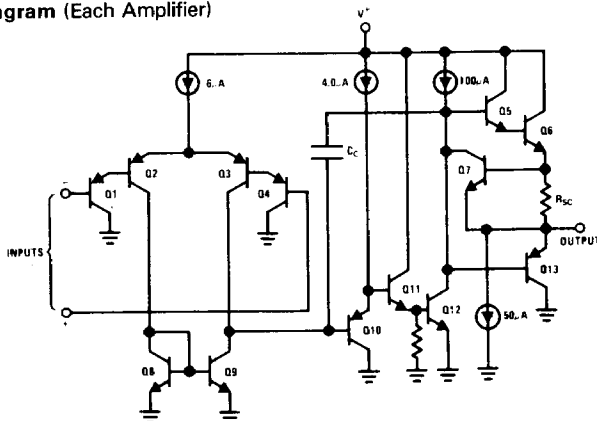

Typical Performance Characteristics

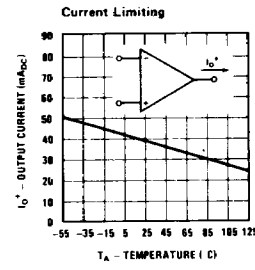
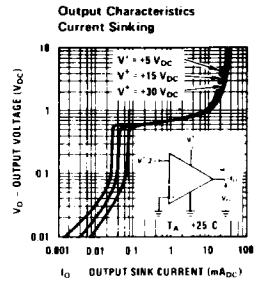
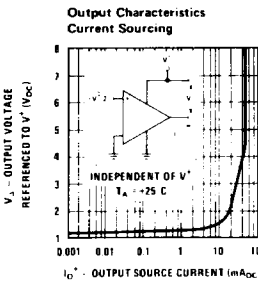
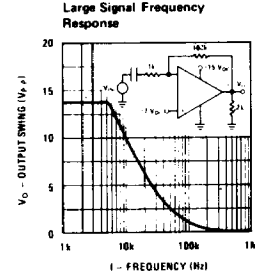
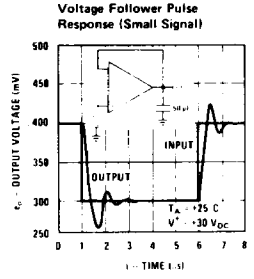
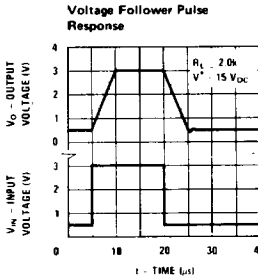
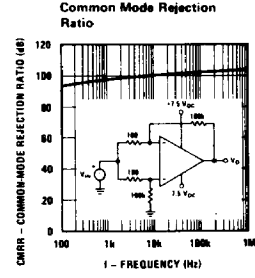
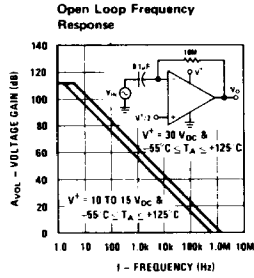
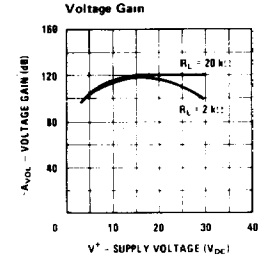
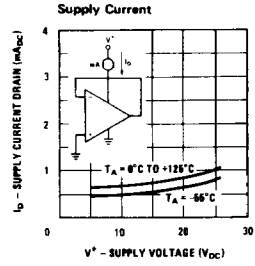
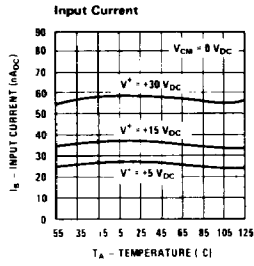
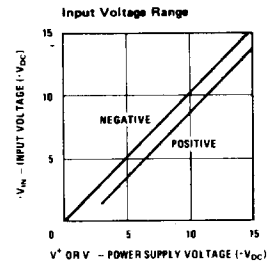

Application Hints

These op amps operate with only a single power supply voltage, have true-differential inputs, and remain in the linear mode with an input common-mode voltage of $0V_{DC}$. These amplifiers operate over a wide range of power supply voltage with little change in performance characteristics. AT 25°C amplifier operation is possible down to a minimum supply voltage of $2.3V_{DC}$.

Precautions should be taken to insure that the power supply for the integrated circuit never becomes reversed in polarity or that the unit is not inadvertently installed backwards in a test socket as an unlimited current surge through the resulting forward diode within the IC could cause fusing of the internal conductors and result in a destroyed unit.

Large differential input voltages can be easily accommodated and, as input differential voltage protection diodes are not needed, no large input currents result from large differential input voltages. The differential input voltage may be larger than $V+$ without damaging the device. Protection should be provided to prevent the input voltages from going negative more than $-0.3VDC$ (at $25^{\circ}C$). An input clamp diode with a resistor to the IC input terminal can be used.

To reduce the power supply current drain, the amplifiers have a class A output stage for small signal levels which converts to class B in a large signal mode. This allows the amplifiers to both source and sink large output currents. Therefore both NPN and PNP external current boost transistors can be used to extend the power capability of the basic amplifiers. The output voltage needs to raise approximately 1 diode drop above ground to bias the on-chip vertical PNP transistor for output current sinking applications.

For ac applications, where the load is capacitively coupled to the output of the amplifier, a resistor should be used, from the output of the amplifier to ground to increase the class A bias current and prevent crossover distortion. Where the load is directly coupled, as in dc applications, there is no crossover distortion.

Capacitive loads which are applied directly to the output of the amplifier reduce the loop stability margin. Values of $50pF$ can be accommodated using the worst-case non-inverting unity gain connection. Large closed loop gains or resistive isolation should be used if larger load capacitance must be driven by the amplifier.

The bias network establishes a drain current which is independent of the magnitude of the power supply voltage over the range of from $3VDC$ to $30VDC$.

Output short circuits either to ground or to the positive power supply should be of short time duration. Units can be destroyed, not as a result of the short circuit current causing metal fusing, but rather due to the large increase in IC chip dissipation which will cause eventual failure due to excessive junction temperatures. Putting direct short-circuits on more than one amplifier at a time will increase the total IC power dissipation to destructive levels, if not properly protected with external dissipation limiting resistors in series with the output leads of the amplifiers. The larger value of output source current which is available at $25^{\circ}C$ provides a larger output current capability at elevated temperatures (see typical performance characteristics) than a standard IC op amp.

The circuits presented in the section on typical applications emphasize operation on only a single power supply voltage. If complementary power supplies are available, all of the standard op amp circuits can be used. In general, introducing a pseudo-ground (a bias voltage reference of $V+/2$) will allow operation above and below this value in single power supply systems. Many application circuits are shown which take advantage of the wide input common-mode voltage range which includes ground. In most cases, input biasing is not required and input voltages which range to ground can easily be accommodated.

Typical Single-Supply Applications ($V+ = 5.0VDC$)

"BI-QUAD" RC Active Bandpass Filter

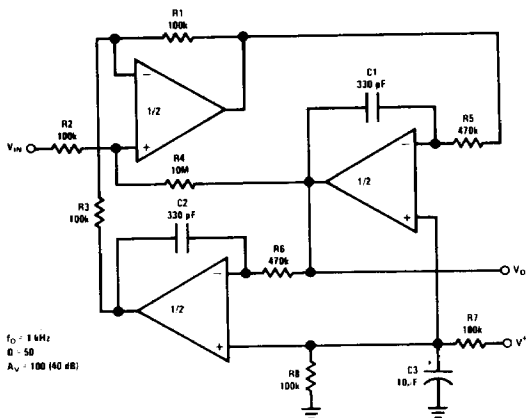

Fixed Current Sources

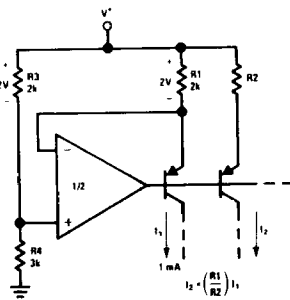

Non-Inverting DC Gain (0V Input = 0V Output)

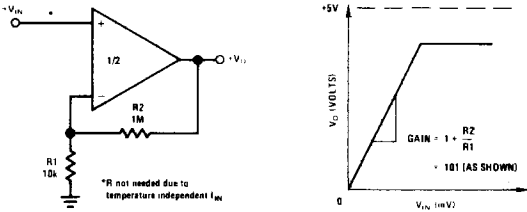

Squarewave Oscillator

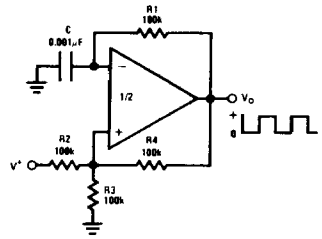

Voltage Controlled Oscillator (VCO)

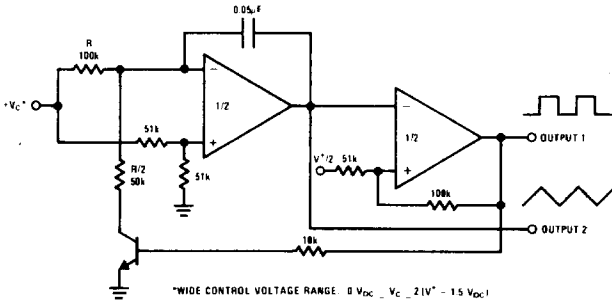

Current Monitor

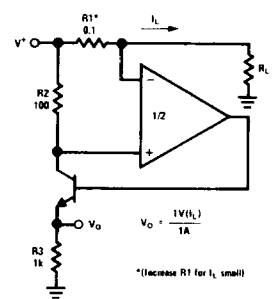

Driving TTL

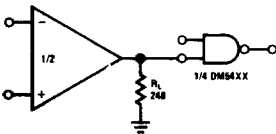

LED Driver

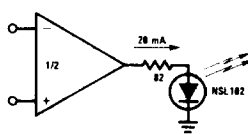

Comparator with Hysteresis

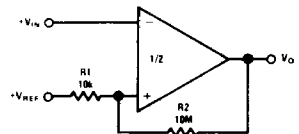

Lamp Driver

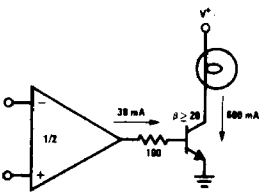

Voltage Follower

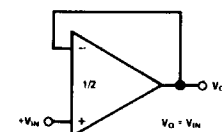

High Compliance Current Sink

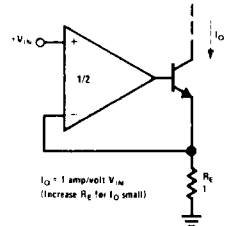

Pulse Generator

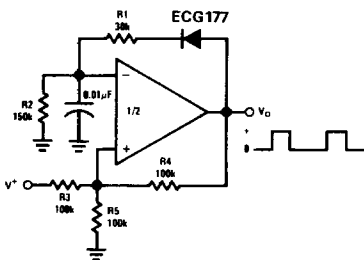

Pulse Generator

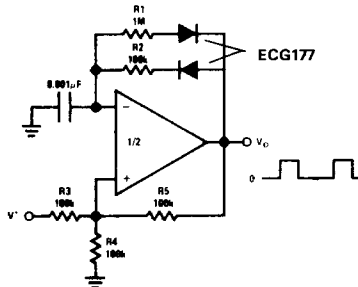

High Input Z Adjustable-Gain DC Instrumentation Amplifier

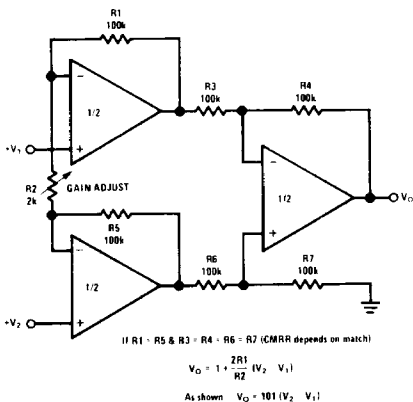

Using Symmetrical Amplifiers to Reduce Input Current (General Concept)

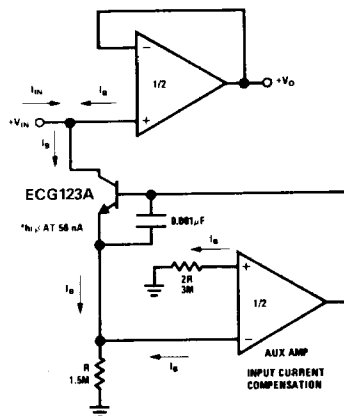

DC Summing Amplifier ($V_{IN'S} \geq 0 V_{DC}$ AND $V_O \geq 0 V_{DC}$)

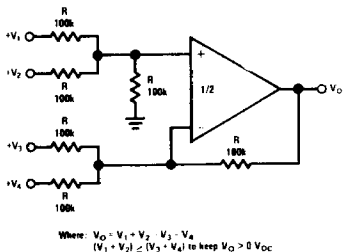

AC Coupled Inverting Amplifier

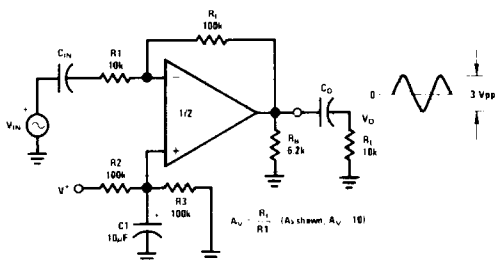

High Input Z, DC Differential Amplifier

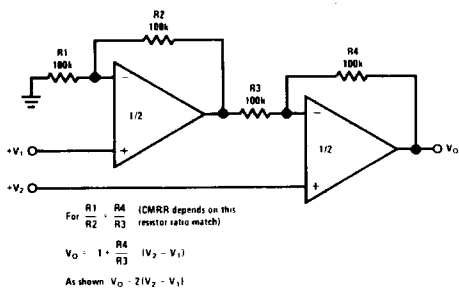

AC Coupled Non-Inverting Amplifier

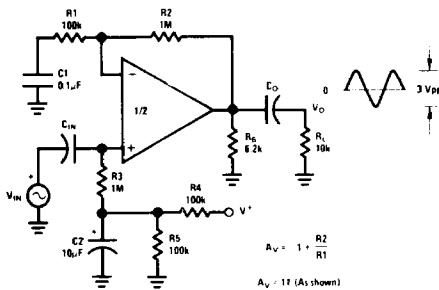

Power Amplifier

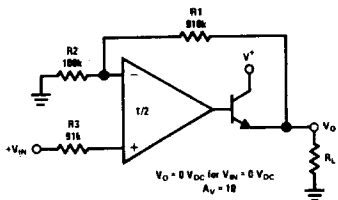
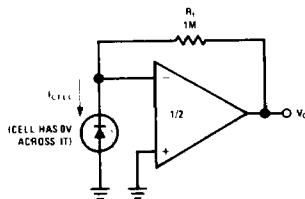
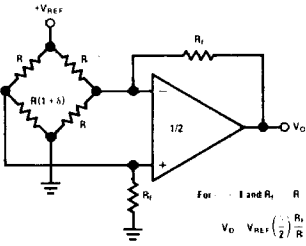

Photo Voltaic-Cell Amplifier



Bridge Current Amplifier



Bandpass Active Filter

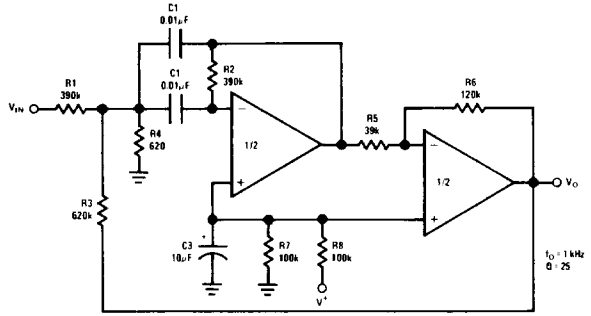

DC Coupled Low-Pass RC Active Filter

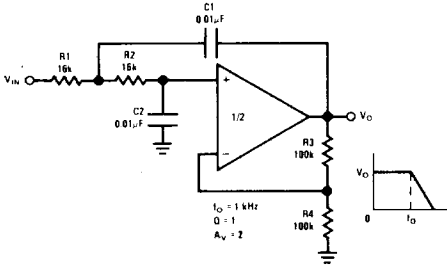

Ground Referencing A Differential Input Signal

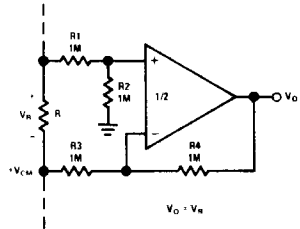

Low Drift Peak Detector

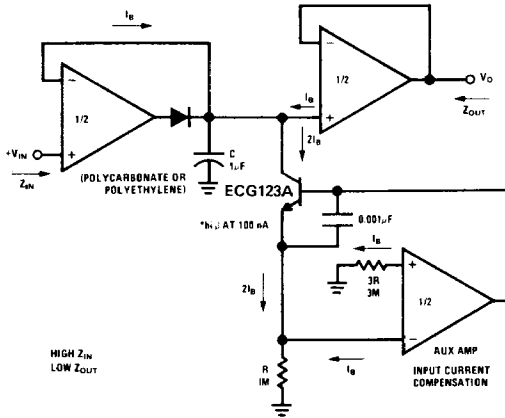

The information contained herein is believed to be accurate. However, no responsibility is assumed by Philips ECG, Inc. for its use nor for any infringements of patents or other rights of third parties which may result from its use.