

2.7V 10-Bit A/D Converter with SPI™ Serial Interface

FEATURES

- 10-bit resolution
- ± 1 LSB max DNL
- ± 1 LSB max INL
- On-chip sample and hold
- SPI serial interface (modes 0,0 and 1,1)
- Single supply operation: 2.7V - 5.5V
- 200ksps sampling rate at 5V
- 75ksps sampling rate at 2.7V
- Low power CMOS technology
 - 5nA typical standby current, 2 μ A max
 - 500 μ A max active current at 5V
- Industrial temp range: -40°C to +85°C
- 8-pin PDIP, SOIC and TSSOP packages

APPLICATIONS

- Sensor Interface
- Process Control
- Data Acquisition
- Battery Operated Systems

DESCRIPTION

The Microchip Technology Inc. MCP3001 is a successive approximation 10-bit A/D converter (ADC) with on-board sample and hold circuitry. The device provides a single pseudo-differential input. Differential Nonlinearity (DNL) and Integral Nonlinearity (INL) are both specified at ± 1 LSB max. Communication with the device is done using a simple serial interface compatible with the SPI protocol. The device is capable of sample rates of up to 200ksps at a clock rate of 2.8MHz. The MCP3001 operates over a broad voltage range (2.7V - 5.5V). Low current design permits operation with a typical standby current of only 5nA and a typical active current of 400 μ A. The device is offered in 8 pin PDIP, TSSOP and 150mil SOIC packages.

PACKAGE TYPES

PDIP

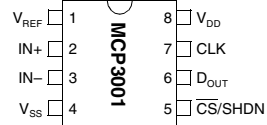

SOIC, TSSOP

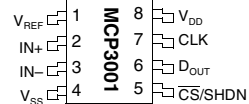

FUNCTIONAL BLOCK DIAGRAM

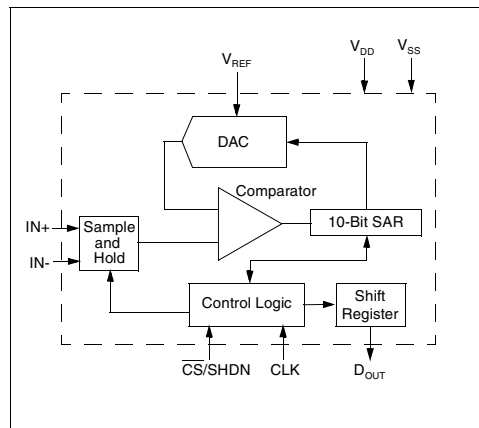

SPI is a trademark of Motorola Inc.

MCP3001

1.0 ELECTRICAL CHARACTERISTICS

1.1 Maximum Ratings*

V_{DD} 7.0V
 All inputs and outputs w.r.t. V_{SS} -0.6V to $V_{DD} + 0.6V$
 Storage temperature -65°C to +150°C
 Ambient temp. with power applied -65°C to +125°C
 Soldering temperature of leads (10 seconds) .. +300°C
 ESD protection on all pins > 4kV

*Notice: Stresses above those listed under "Maximum ratings" may cause permanent damage to the device. This is a stress rating only and functional operation of the device at those or any other conditions above those indicated in the operational listings of this specification is not implied. Exposure to maximum rating conditions for extended periods may affect device reliability.

PIN FUNCTION TABLE

NAME	FUNCTION
V_{DD}	+2.7V to 5.5V Power Supply
V_{SS}	Ground
IN+	Positive Analog Input
IN-	Negative Analog Input
CLK	Serial Clock
D_{OUT}	Serial Data Out
$\overline{CS}/SHDN$	Chip select/Shutdown Input
V_{REF}	Reference Voltage Input

ELECTRICAL CHARACTERISTICS

All parameters apply at $V_{DD} = 5V$, $V_{SS} = 0V$, $V_{REF} = 5V$, $T_{AMB} = -40^{\circ}C$ to $+85^{\circ}C$, $f_{SAMPLE} = 200kps$ and $f_{CLK} = 14 * f_{SAMPLE}$ unless otherwise noted. Typical values apply for $V_{DD} = 5V$, $T_{AMB} = 25^{\circ}C$ unless otherwise noted.

PARAMETER	SYMBOL	MIN.	TYP.	MAX.	UNITS	CONDITIONS
Conversion Rate						
Conversion Time	t_{CONV}			10	clock cycles	
Analog Input Sample Time	t_{SAMPLE}		1.5		clock cycles	
Throughput Rate	f_{SAMPLE}			200 75	kspss kspss	$V_{DD} = V_{REF} = 5V$ $V_{DD} = V_{REF} = 2.7V$
DC Accuracy						
Resolution			10		bits	
Integral Nonlinearity	INL		±0.5	±1	LSB	
Differential Nonlinearity	DNL		±0.25	±1	LSB	No missing codes over temperature
Offset Error				±1.5	LSB	
Gain Error				±1	LSB	
Dynamic Performance						
Total Harmonic Distortion			-76		dB	$V_{IN} = 0.1V$ to $4.9V @ 1kHz$
Signal to Noise and Distortion (SINAD)			61		dB	$V_{IN} = 0.1V$ to $4.9V @ 1kHz$
Spurious Free Dynamic Range			80		dB	$V_{IN} = 0.1V$ to $4.9V @ 1kHz$
Reference Input						
Voltage Range		0.25		V_{DD}	V	Note 2
Current Drain			90 0.001	150 3	µA µA	$\overline{CS} = V_{DD} = 5V$
Analog Inputs						
Input Voltage Range (IN+)		IN-		$V_{REF} + IN-$	V	
Input Voltage Range (IN-)		$V_{SS} - 100$		$V_{SS} + 100$	mV	
Leakage Current			0.001	±1	µA	
Switch Resistance	R_{SS}		1K		Ω	See Figure 4-1
Sample Capacitor	C_{SAMPLE}		20		pF	See Figure 4-1

ELECTRICAL CHARACTERISTICS (CONTINUED)

All parameters apply at $V_{DD} = 5V$, $V_{SS} = 0V$, $V_{REF} = 5V$, $T_{AMB} = -40^{\circ}C$ to $+85^{\circ}C$, $f_{SAMPLE} = 200ksps$ and $f_{CLK} = 14 * f_{SAMPLE}$ unless otherwise noted. Typical values apply for $V_{DD} = 5V$, $T_{AMB} = 25^{\circ}C$ unless otherwise noted.

PARAMETER	SYMBOL	MIN.	TYP.	MAX.	UNITS	CONDITIONS
Digital Input/Output						
Data Coding Format		Straight Binary				
High Level Input Voltage	V_{IH}	$0.7 V_{DD}$		—	V	
Low Level Input Voltage	V_{IL}	—		$0.3 V_{DD}$	V	
High Level Output Voltage	V_{OH}	4.1		—	V	$I_{OH} = -1mA$, $V_{DD} = 4.5V$
Low Level Output Voltage	V_{OL}	—		0.4	V	$I_{OL} = 1mA$, $V_{DD} = 4.5V$
Input Leakage Current	I_{LI}	-10		10	μA	$V_{IN} = V_{SS}$ or V_{DD}
Output Leakage Current	I_{LO}	-10		10	μA	$V_{OUT} = V_{SS}$ or V_{DD}
Pin Capacitance (all inputs/outputs)	C_{IN} , C_{OUT}	—		10	pF	$V_{DD} = 5.0V$ (Note 1) $T_{AMB} = 25^{\circ}C$, $f = 1$ MHz
Timing Parameters						
Clock Frequency	f_{CLK}			2.8 1.05	MHz MHz	$V_{DD} = 5V$ (Note 3) $V_{DD} = 2.7V$ (Note 3)
Clock High Time	t_{HI}	160			ns	
Clock Low Time	t_{LO}	160			ns	
CS Fall To First Rising CLK Edge	t_{SUCS}	100			ns	
CLK Fall To Output Data Valid	t_{DO}			125 200	ns ns	$V_{DD} = 5V$, See Figure 1-2 $V_{DD} = 2.7$, See Figure 1-2
CLK Fall To Output Enable	t_{EN}			125 200	ns ns	$V_{DD} = 5V$, See Figure 1-2 $V_{DD} = 2.7$, See Figure 1-2
CS Rise To Output Disable	t_{DIS}			100	ns	See test circuits, Figure 1-2 (Note 1)
CS Disable Time	t_{CSH}	350			ns	
D_{OUT} Rise Time	t_R			100	ns	See test circuits, Figure 1-2 (Note 1)
D_{OUT} Fall Time	t_F			100	ns	See test circuits, Figure 1-2 (Note 1)
Power Requirements						
Operating Voltage	V_{DD}	2.7		5.5	V	
Operating Current	I_{DD}		400 210	500	μA μA	$V_{DD} = 5.0V$, D_{OUT} unloaded $V_{DD} = 2.7V$, D_{OUT} unloaded
Standby Current	I_{DSS}		0.005	2	μA	CS = $V_{DD} = 5.0V$

Note 1: This parameter is guaranteed by characterization and not 100% tested.

2: See graph that relates linearity performance to V_{REF} level.

3: Because the sample cap will eventually lose charge, clock rates below 10kHz can affect linearity performance, especially at elevated temperatures.

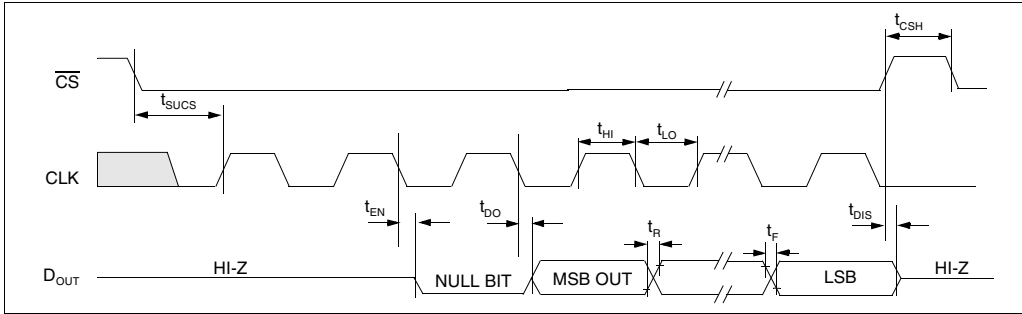

FIGURE 1-1: Serial Timing.

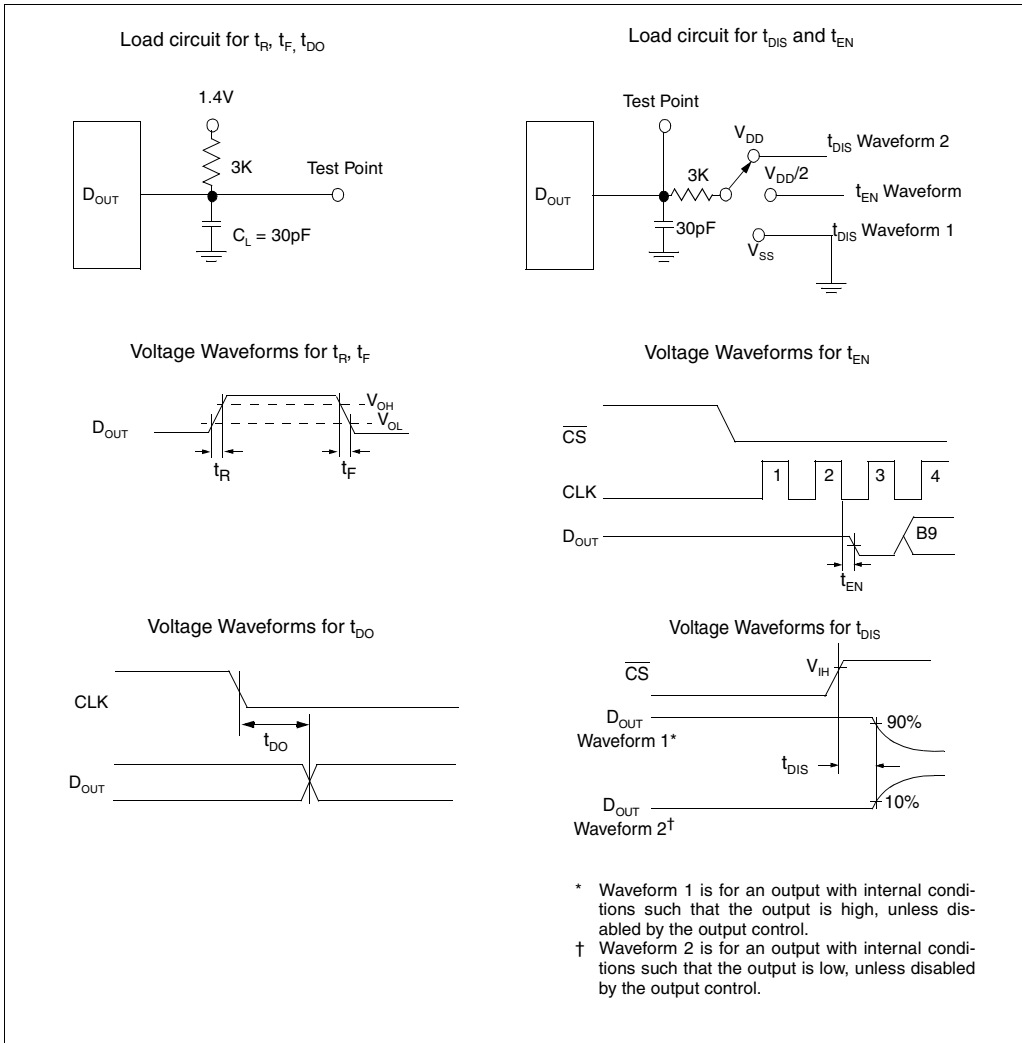

FIGURE 1-2: Test Circuits.

2.0 TYPICAL PERFORMANCE CHARACTERISTICS

Note: Unless otherwise indicated, $V_{DD} = V_{REF} = 5V$, $f_{SAMPLE} = 200\text{kpsps}$, $f_{CLK} = 14 \times \text{Sample Rate}$, $T_A = 25^\circ\text{C}$

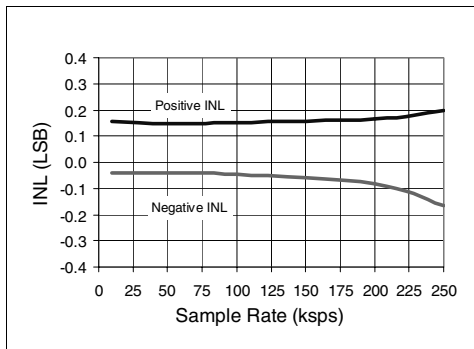

FIGURE 2-1: Integral Nonlinearity (INL) vs. Sample Rate.

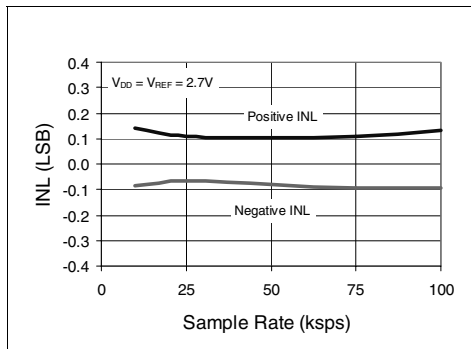

FIGURE 2-4: Integral Nonlinearity (INL) vs. Sample Rate ($V_{DD} = 2.7V$).

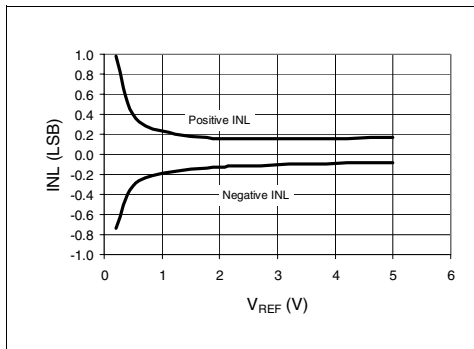

FIGURE 2-2: Integral Nonlinearity (INL) vs. V_{REF} .

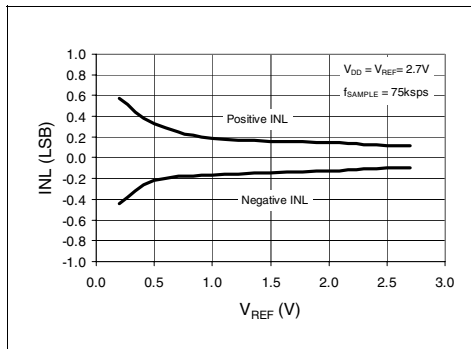

FIGURE 2-5: Integral Nonlinearity (INL) vs. V_{REF} ($V_{DD} = 2.7V$)

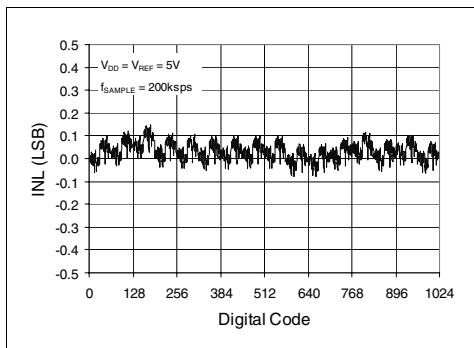

FIGURE 2-3: Integral Nonlinearity (INL) vs. Code (Representative Part).

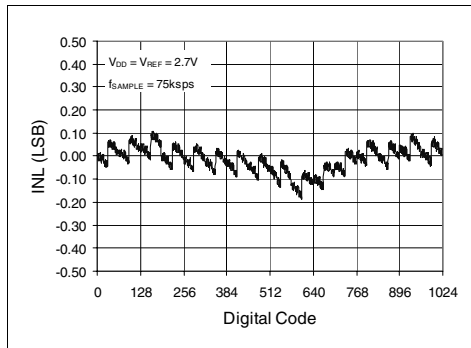

FIGURE 2-6: Integral Nonlinearity (INL) vs. Code (Representative Part, $V_{DD} = 2.7V$).

MCP3001

Note: Unless otherwise indicated, $V_{DD} = V_{REF} = 5V$, $f_{SAMPLE} = 200\text{ksps}$, $f_{CLK} = 14 \times \text{Sample Rate}$, $T_A = 25^\circ\text{C}$

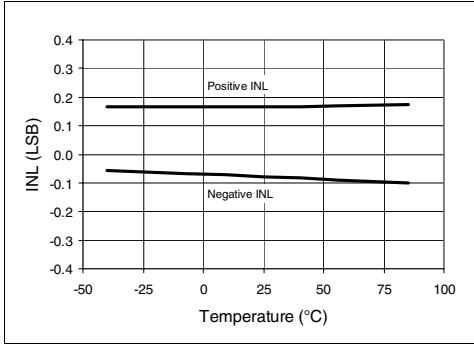

FIGURE 2-7: Integral Nonlinearity (INL) vs. Temperature.

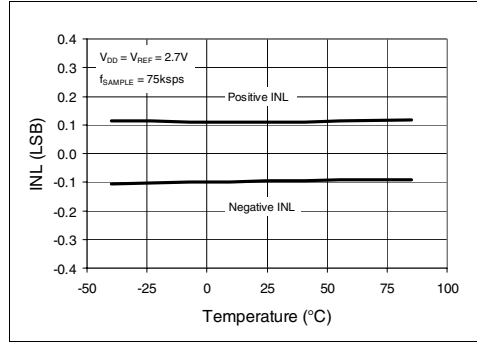

FIGURE 2-10: Integral Nonlinearity (INL) vs. Temperature ($V_{DD} = 2.7V$).

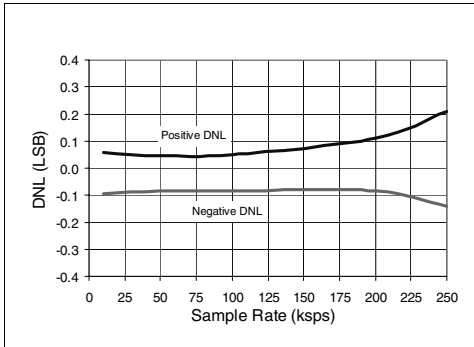

FIGURE 2-8: Differential Nonlinearity (DNL) vs. Sample Rate.

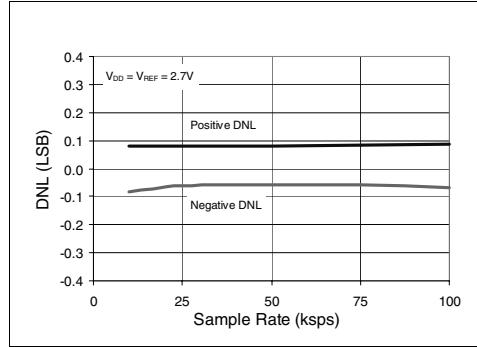

FIGURE 2-11: Differential Nonlinearity (DNL) vs. Sample Rate ($V_{DD} = 2.7V$).

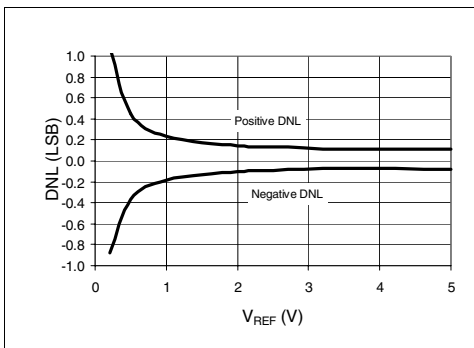

FIGURE 2-9: Differential Nonlinearity (DNL) vs. V_{REF}

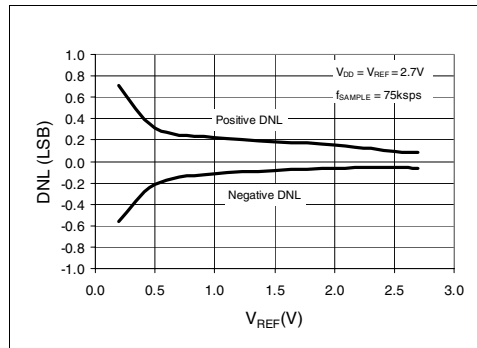

FIGURE 2-12: Differential Nonlinearity (DNL) vs. V_{REF} ($V_{DD} = 2.7V$).

Note: Unless otherwise indicated, $V_{DD} = V_{REF} = 5V$, $f_{SAMPLE} = 200\text{kpsps}$, $f_{CLK} = 14 \times \text{Sample Rate}$, $T_A = 25^\circ\text{C}$

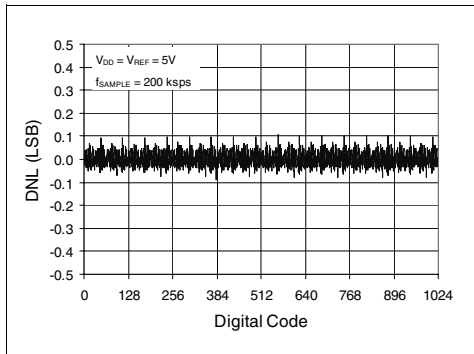

FIGURE 2-13: Differential Nonlinearity (DNL) vs. Code (Representative Part).

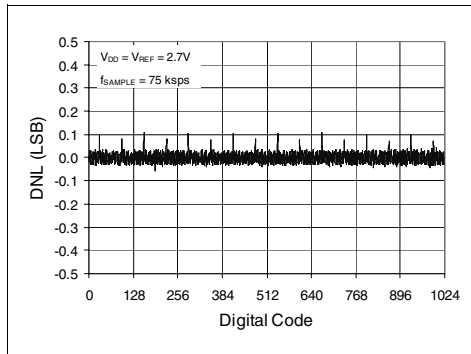

FIGURE 2-16: Differential Nonlinearity (DNL) vs. Code (Representative Part, $V_{DD} = 2.7V$).

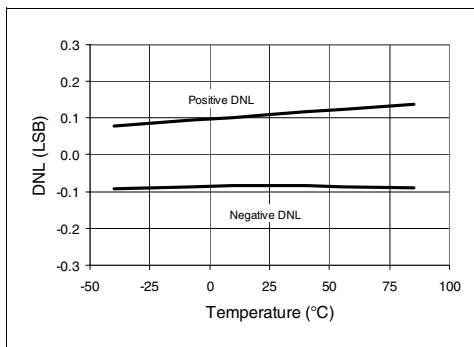

FIGURE 2-14: Differential Nonlinearity (DNL) vs. Temperature.

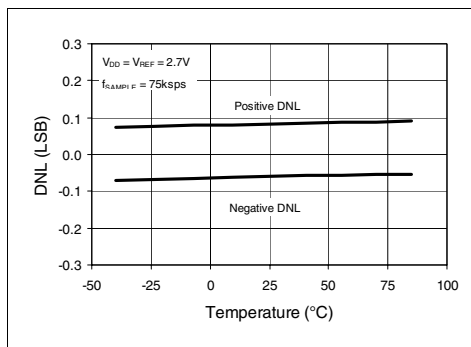

FIGURE 2-17: Differential Nonlinearity (DNL) vs. Temperature ($V_{DD} = 2.7V$).

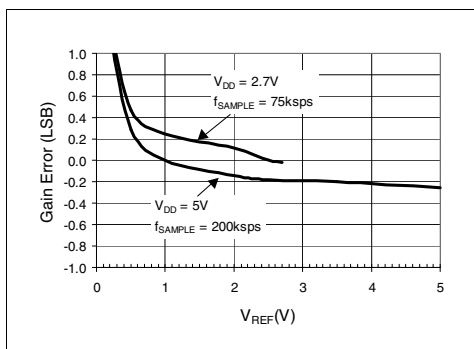

FIGURE 2-15: Gain Error vs. V_{REF} .

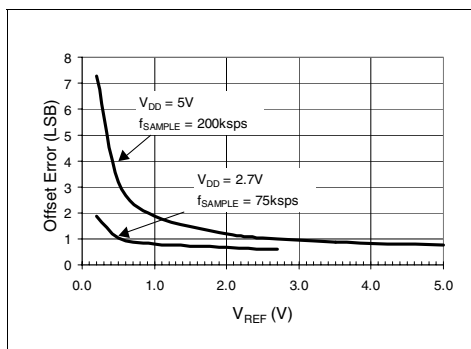

FIGURE 2-18: Offset Error vs. V_{REF} .

MCP3001

Note: Unless otherwise indicated, $V_{DD} = V_{REF} = 5V$, $f_{SAMPLE} = 200\text{kSPS}$, $f_{CLK} = 14 \times \text{Sample Rate}$, $T_A = 25^\circ\text{C}$

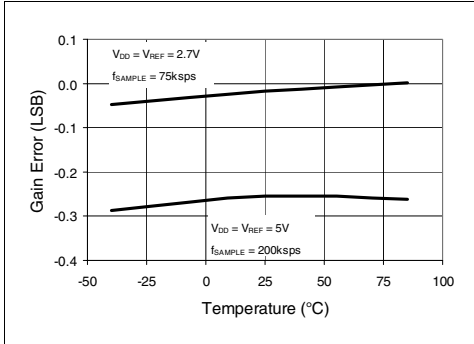

FIGURE 2-19: Gain Error vs. Temperature.

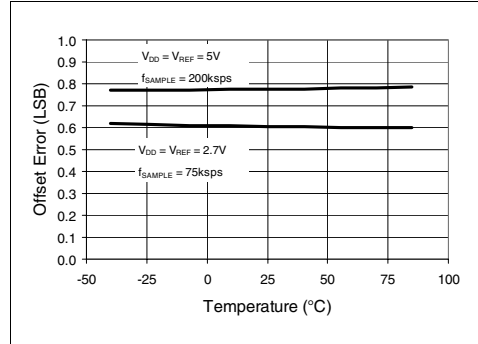

FIGURE 2-22: Offset Error vs. Temperature.

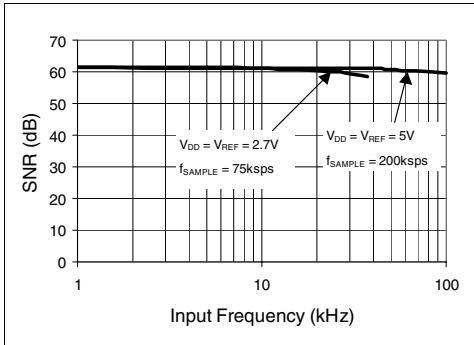

FIGURE 2-20: Signal to Noise Ratio (SNR) vs. Input Frequency.

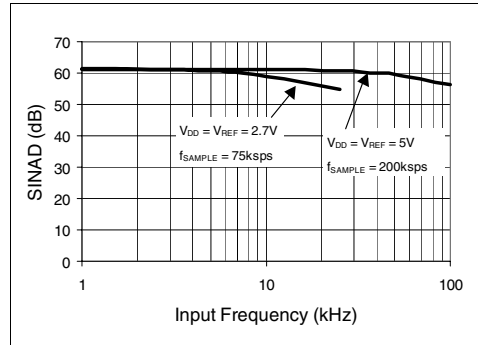

FIGURE 2-23: Signal to Noise and Distortion (SINAD) vs. Input Frequency.

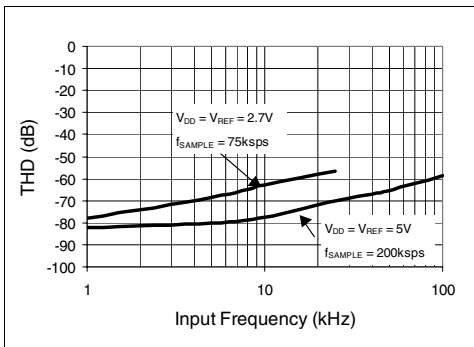

FIGURE 2-21: Total Harmonic Distortion (THD) vs. Input Frequency.

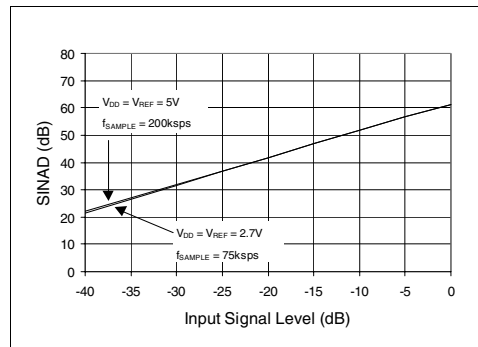

FIGURE 2-24: Signal to Noise and Distortion (SINAD) vs. Input Signal Level.

Note: Unless otherwise indicated, $V_{DD} = V_{REF} = 5V$, $f_{SAMPLE} = 200\text{kpsps}$, $f_{CLK} = 14 * \text{Sample Rate}$, $T_A = 25^\circ\text{C}$

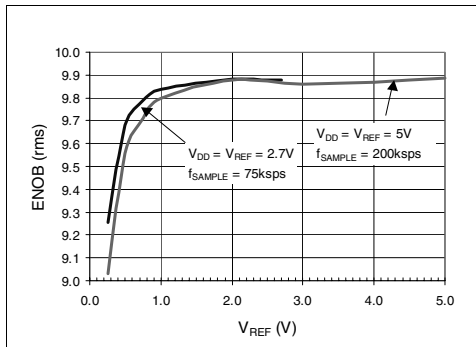

FIGURE 2-25: Effective Number of Bits (ENOB) vs. V_{REF} .

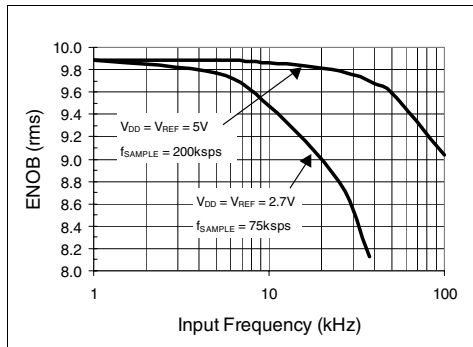

FIGURE 2-28: Effective Number of Bits (ENOB) vs. Input Frequency.

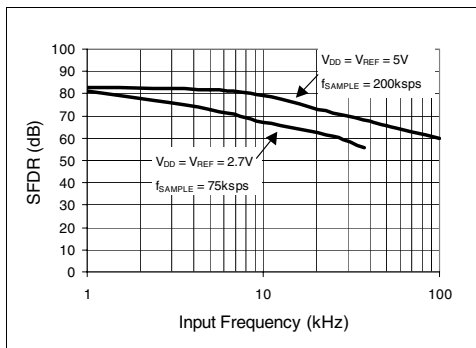

FIGURE 2-26: Spurious Free Dynamic Range (SFDR) vs. Input Frequency.

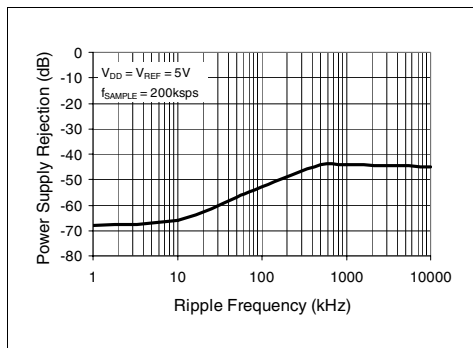

FIGURE 2-29: Power Supply Rejection (PSR) vs. Ripple Frequency.

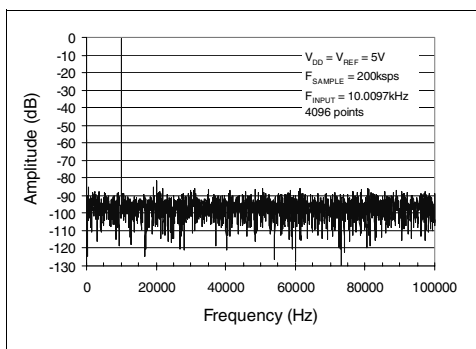

FIGURE 2-27: Frequency Spectrum of 10kHz input (Representative Part).

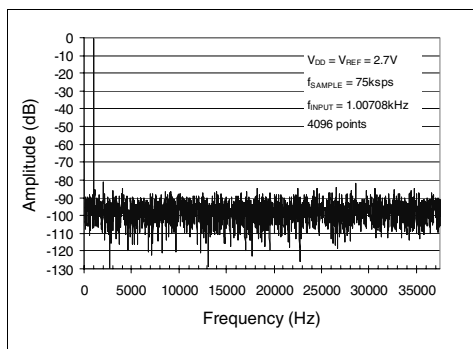

FIGURE 2-30: Frequency Spectrum of 1kHz input (Representative Part, $V_{DD} = 2.7V$).

MCP3001

Note: Unless otherwise indicated, $V_{DD} = V_{REF} = 5V$, $f_{SAMPLE} = 200\text{ksps}$, $f_{CLK} = 14 \times \text{Sample Rate}$, $T_A = 25^\circ\text{C}$

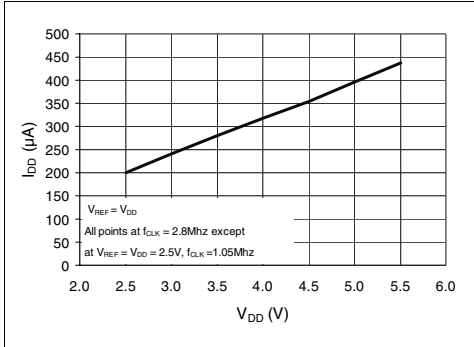

FIGURE 2-31: I_{DD} vs. V_{DD} .

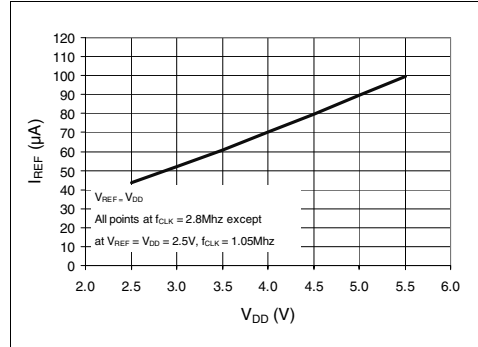

FIGURE 2-34: I_{REF} vs. V_{DD} .

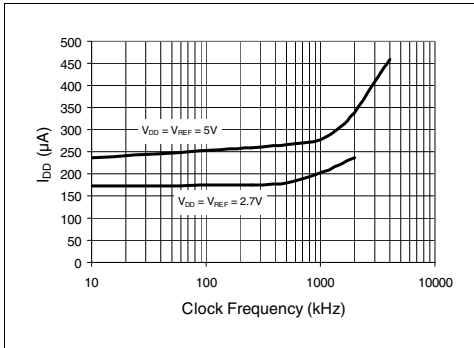

FIGURE 2-32: I_{DD} vs. Clock Frequency.

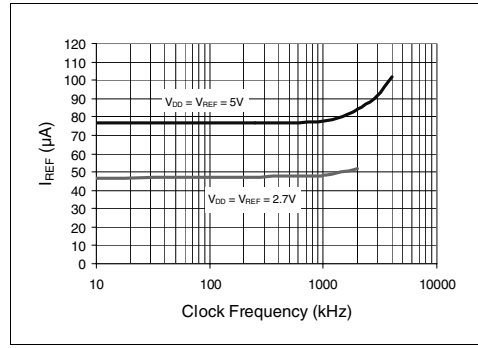

FIGURE 2-35: I_{REF} vs. Clock Frequency.

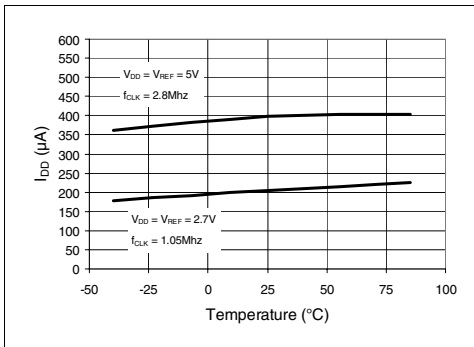

FIGURE 2-33: I_{DD} vs. Temperature.

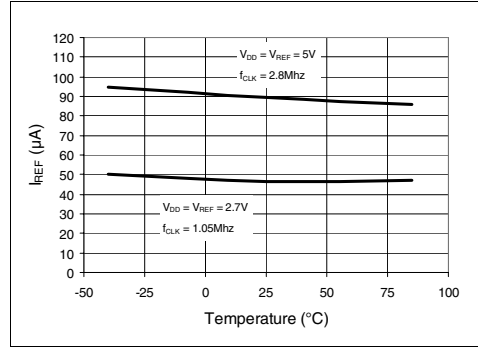

FIGURE 2-36: I_{REF} vs. Temperature.

Note: Unless otherwise indicated, $V_{DD} = V_{REF} = 5V$, $f_{SAMPLE} = 200\text{kpsps}$, $f_{CLK} = 14 \times \text{Sample Rate}$, $T_A = 25^\circ\text{C}$

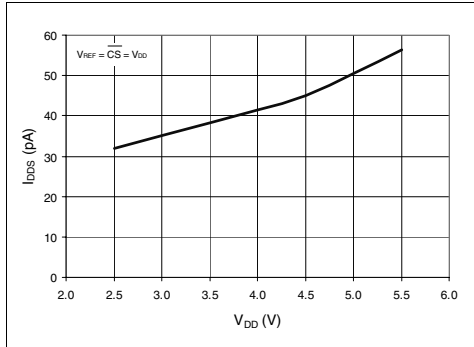

FIGURE 2-37: I_{DDs} vs. V_{DD} .

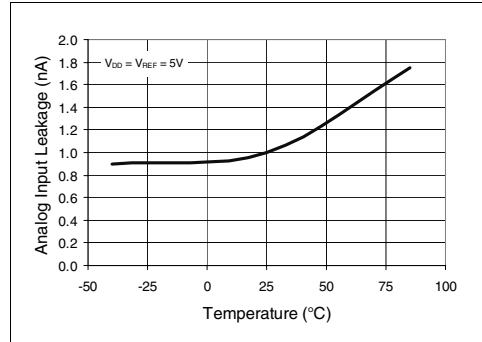

FIGURE 2-39: Analog Input Leakage Current vs. Temperature.

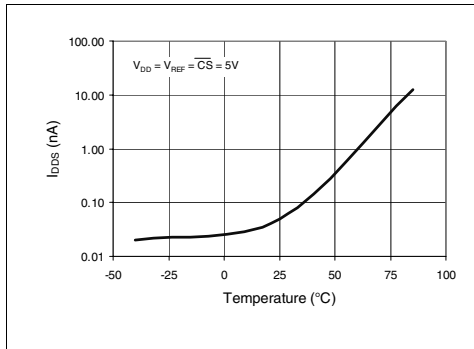

FIGURE 2-38: I_{DDs} vs. Temperature.

3.0 PIN DESCRIPTIONS

3.1 IN+

Positive analog input. This input can vary from IN- to $V_{REF} + IN-$.

3.2 IN-

Negative analog input. This input can vary $\pm 100\text{mV}$ from V_{SS} .

3.3 $\overline{CS}/\overline{SHDN}$ (Chip Select/Shutdown)

The $\overline{CS}/\overline{SHDN}$ pin is used to initiate communication with the device when pulled low and will end a conversion and put the device in low power standby when pulled high. The $\overline{CS}/\overline{SHDN}$ pin must be pulled high between conversions.

3.4 CLK (Serial Clock)

The SPI clock pin is used to initiate a conversion and to clock out each bit of the conversion as it takes place. See Section 6.2 for constraints on clock speed.

3.5 DOUT (Serial Data output)

The SPI serial data output pin is used to shift out the results of the A/D conversion. Data will always change on the falling edge of each clock as the conversion takes place.

4.0 DEVICE OPERATION

The MCP3001 A/D converter employs a conventional SAR architecture. With this architecture, a sample is acquired on an internal sample/hold capacitor for 1.5 clock cycles starting on the first rising edge of the serial clock after \overline{CS} has been pulled low. Following this sample time, the input switch of the converter opens and the device uses the collected charge on the internal sample and hold capacitor to produce a serial 10-bit digital output code. Conversion rates of 200ksp/s are possible on the MCP3001. See Section 6.2 for information on minimum clock rates. Communication with the device is done using a 3-wire SPI-compatible interface.

4.1 Analog Inputs

The MCP3001 provides a single pseudo-differential input. The IN+ input can range from IN- to $(V_{REF} + IN-)$. The IN- input is limited to $\pm 100\text{mV}$ from the V_{SS} rail. The IN- input can be used to cancel small signal common-mode noise which is present on both the IN+ and IN- inputs.

For the A/D Converter to meet specification, the charge holding capacitor (C_{SAMPLE}) must be given enough time to acquire a 10-bit accurate voltage level during the 1.5 clock cycle sampling period. The analog input model is shown in Figure 4-1.

In this diagram, it is shown that the source impedance (R_S) adds to the internal sampling switch (R_{SS}) impedance, directly affecting the time that is required to charge the capacitor (C_{SAMPLE}). Consequently, a larger source impedance increases the offset, gain, and integral linearity errors of the conversion.

Ideally, the impedance of the signal source should be near zero. This is achievable with an operational amplifier such as the MCP601, which has a closed loop output impedance of tens of ohms. The adverse affects of higher source impedances are shown in Figure 4-2.

If the voltage level of IN+ is equal to or less than IN-, the resultant code will be 000h. If the voltage at IN+ is equal to or greater than $\{[V_{REF} + (IN-)] - 1 \text{ LSB}\}$, then the output code will be 3FFh. If the voltage level at IN- is more than 1 LSB below V_{SS} , then the voltage level at the IN+ input will have to go below V_{SS} to see the 000h output code. Conversely, if IN- is more than 1 LSB above V_{SS} , then the 3FFh code will not be seen unless the IN+ input level goes above V_{REF} level.

4.2 Reference Input

The reference input (V_{REF}) determines the analog input voltage range and the LSB size, as shown below.

$$\text{LSB Size} = \frac{V_{REF}}{1024}$$

As the reference input is reduced, the LSB size is reduced accordingly. The theoretical digital output code produced by the A/D Converter is a function of the analog input signal and the reference input as shown below.

$$\text{Digital Output Code} = \frac{1024 * V_{IN}}{V_{REF}}$$

where:

$$V_{IN} = \text{analog input voltage} = V(IN+) - V(IN-)$$

$$V_{REF} = \text{reference voltage}$$

When using an external voltage reference device, the system designer should always refer to the manufacturer's recommendations for circuit layout. Any instability in the operation of the reference device will have a direct effect on the operation of the ADC.

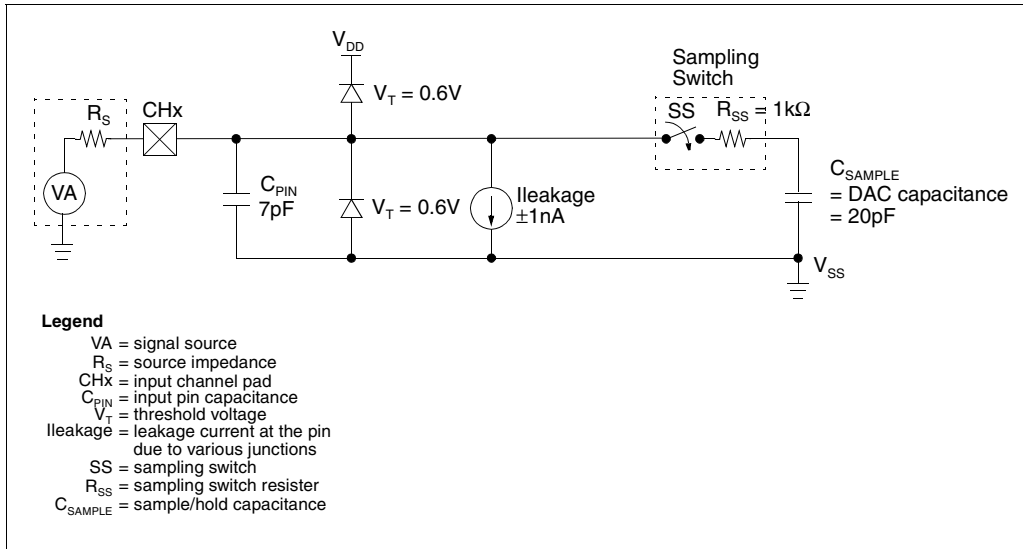

FIGURE 4-1: Analog Input Model.

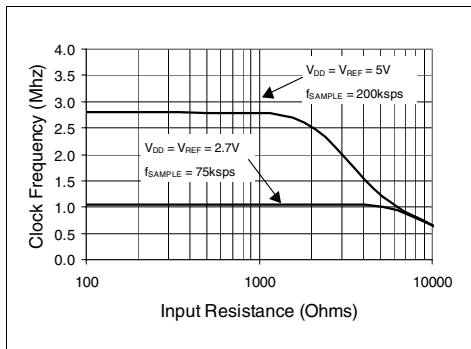

FIGURE 4-2: Maximum Clock Frequency vs. Input Resistance (R_S) to maintain less than a 0.1LSB deviation in INL from nominal conditions.

5.0 SERIAL COMMUNICATIONS

Communication with the device is done using a standard SPI compatible serial interface. Initiating communication with the MCP3001 begins with the \overline{CS} going low. If the device was powered up with the \overline{CS} pin low, it must be brought high and back low to initiate communication. The device will begin to sample the analog input on the first rising edge after \overline{CS} goes low. The sample period will end in the falling edge of the second clock, at which time the device will output a low null bit. The next 10 clocks will output the result of the conversion with MSB first, as shown in Figure 5-1. Data is always output from the device on the falling edge of the clock. If all 10 data bits have been transmitted and the

device continues to receive clocks while the \overline{CS} is held low, the device will output the conversion result LSB first, as shown in Figure 5-2. If more clocks are provided to the device while \overline{CS} is still low (after the LSB first data has been transmitted), the device will clock out zeros indefinitely.

If it is desired, the \overline{CS} can be raised to end the conversion period at any time during the transmission. Faster conversion rates can be obtained by using this technique if not all the bits are captured before starting a new cycle. Some system designers use this method by capturing only the highest order 8 bits and 'throwing away' the lower 2 bits.

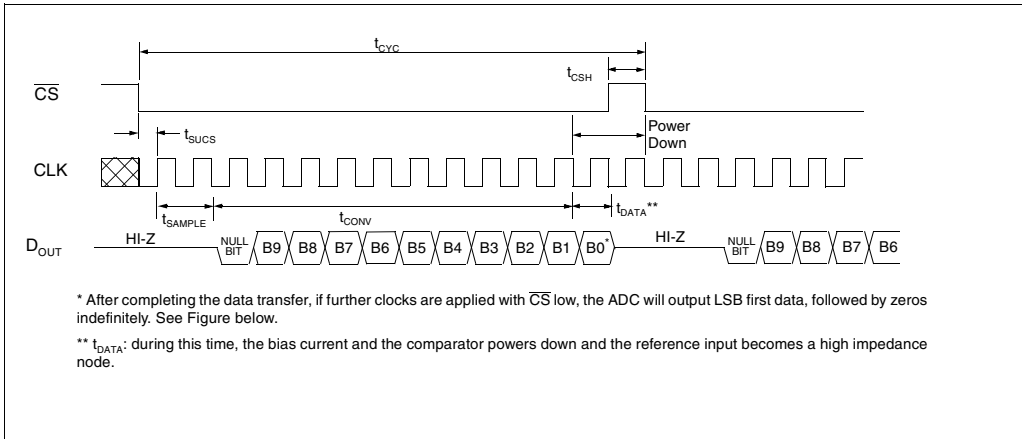

FIGURE 5-1: Communication with MCP3001 (MSB first Format).

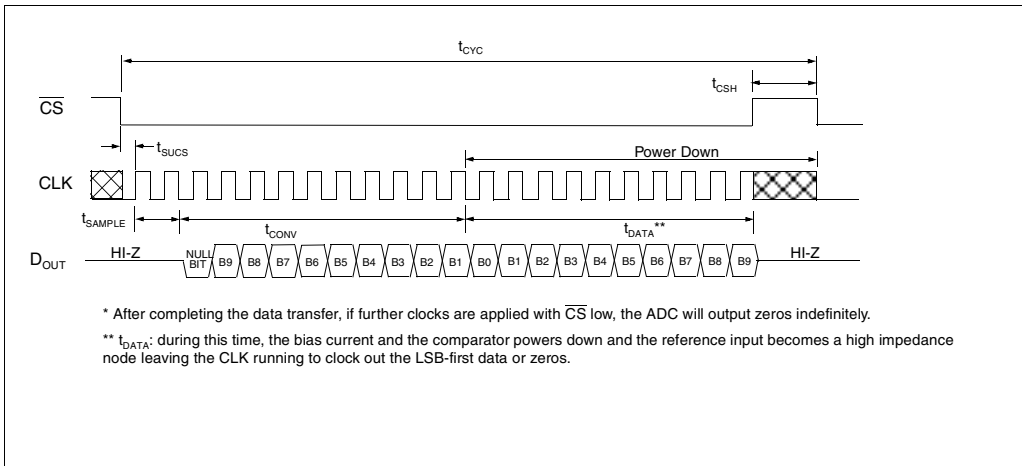

FIGURE 5-2: Communication with MCP3001 (LSB first Format).

6.0 APPLICATIONS INFORMATION

6.1 Using the MCP3001 with Microcontroller SPI Ports

With most microcontroller SPI ports, it is required to clock out eight bits at a time. If this is the case, it will be necessary to provide more clocks than are required for the MCP3001. As an example, Figure 6-1 and Figure 6-2 show how the MCP3001 can be interfaced to a microcontroller with a standard SPI port. Since the MCP3001 always clocks data out on the falling edge of clock, the MCU SPI port must be configured to match this operation. SPI Mode 0,0 (clock idles low) and SPI Mode 1,1 (clock idles high) are both compatible with the MCP3001. Figure 6-1 depicts the operation shown in SPI Mode 0,0, which requires that the CLK from the microcontroller idles in the 'low' state. As shown in the diagram, the MSB is clocked out of the ADC on the falling edge of the third clock pulse. After the first eight clocks have been sent to the device, the microcontrol-

ler's receive buffer will contain two unknown bits (the output is at high impedance for the first two clocks), the null bit and the highest order five bits of the conversion. After the second eight clocks have been sent to the device, the MCU receive register will contain the lowest order five bits and the B1-B4 bits repeated as the ADC has begun to shift out LSB first data with the extra clocks. Typical procedure would then call for the lower order byte of data to be shifted right by three bits to remove the extra B1-B4 bits. The B9-B5 bits are then rotated 3 bits to the right with B7-B5 rotating from the high order byte to the lower order byte. Easier manipulation of the converted data can be obtained by using this method.

Figure 6-2 shows SPI Mode 1,1 communication which requires that the clock idles in the high state. As with mode 0,0, the ADC outputs data on the falling edge of the clock and the MCU latches data from the ADC in on the rising edge of the clock.

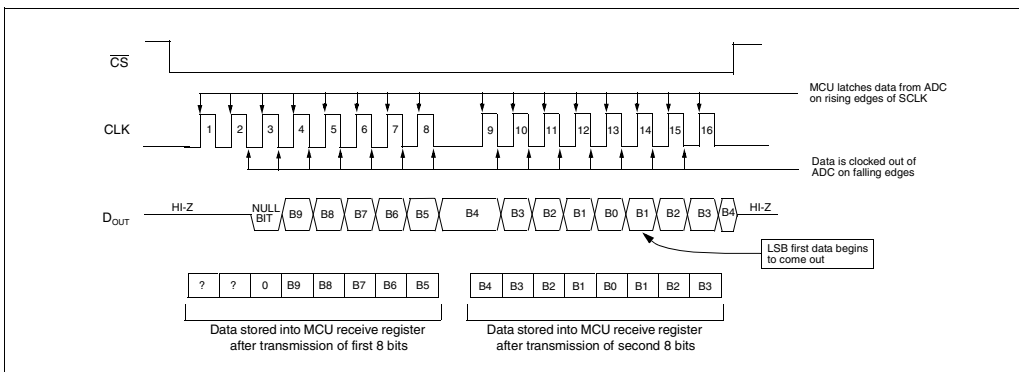

FIGURE 6-1: SPI Communication with the MCP3001 using 8 bit segments (Mode 0,0: SCLK idles low).

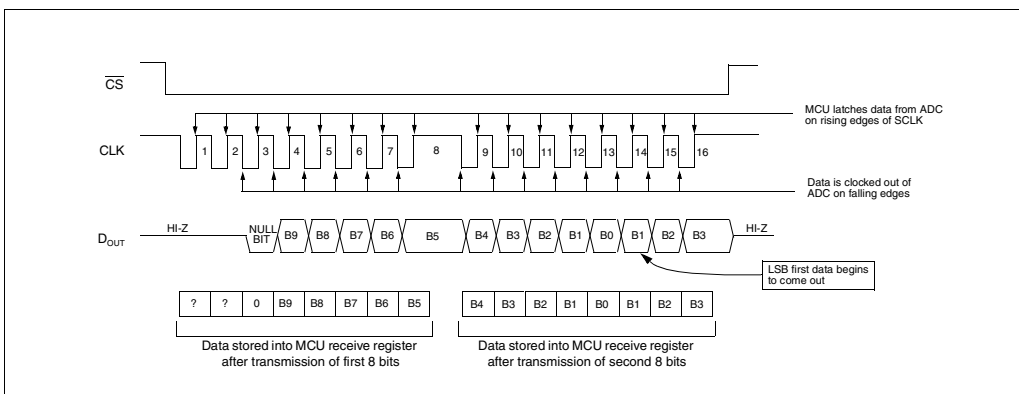

FIGURE 6-2: SPI Communication with the MCP3001 using 8 bit segments (Mode 1,1: SCLK idles high).

6.2 Maintaining Minimum Clock Speed

When the MCP3001 initiates the sample period, charge is stored on the sample capacitor. When the sample period is complete, the device converts one bit for each clock that is received. It is important for the user to note that a slow clock rate will allow charge to bleed off the sample cap while the conversion is taking place. At 85°C (worst case condition), the part will maintain proper charge on the sample cap for 700µs at $V_{DD} = 2.7V$ and 1.5ms at $V_{DD} = 5V$. This means that at $V_{DD} = 2.7V$, the time it takes to transmit the first 14 clocks must not exceed 700µs. Failure to meet this criterion may induce linearity errors into the conversion outside the rated specifications.

6.3 Buffering/Filtering the Analog Inputs

If the signal source for the ADC is not a low impedance source, it will have to be buffered or inaccurate conversion results may occur. See Figure 4-2. It is also recommended that a filter be used to eliminate any signals that may be aliased back into the conversion results. This is illustrated in Figure 6-3 where an op amp is used to drive, filter and gain the analog input of the MCP3001. This amplifier provides a low impedance source for the converter input and a low pass filter, which eliminates unwanted high frequency noise.

Low pass (anti-aliasing) filters can be designed using Microchip's interactive **FilterLab™** software. **FilterLab** will calculate capacitor and resistor values, as well as determine the number of poles that are required for the application. For more information on filtering signals, see the application note AN699 "Anti-Aliasing Analog Filters for Data Acquisition Systems."

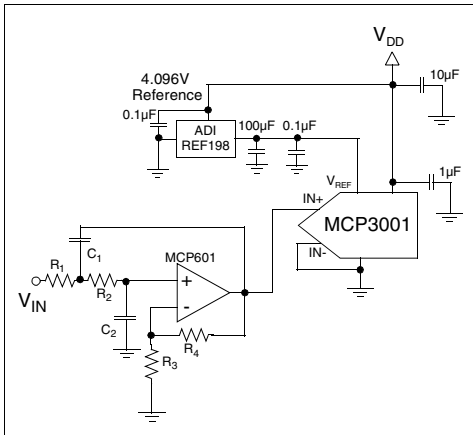

FIGURE 6-3: The MCP601 operational amplifier is used to implement a 2nd order anti-aliasing filter for the signal being converted by the MCP3001.

6.4 Layout Considerations

When laying out a printed circuit board for use with analog components, care should be taken to reduce noise wherever possible. A bypass capacitor should always be used with this device and should be placed as close as possible to the device pin. A bypass capacitor value of 1µF is recommended.

Digital and analog traces should be separated as much as possible on the board and no traces should run underneath the device or the bypass capacitor. Extra precautions should be taken to keep traces with high frequency signals (such as clock lines) as far as possible from analog traces.

Use of an analog ground plane is recommended in order to keep the ground potential the same for all devices on the board. Providing V_{DD} connections to devices in a "star" configuration can also reduce noise by eliminating current return paths and associated errors. See Figure 6-4. For more information on layout tips when using ADC, refer to AN-688 "Layout Tips for 12-Bit A/D Converter Applications".

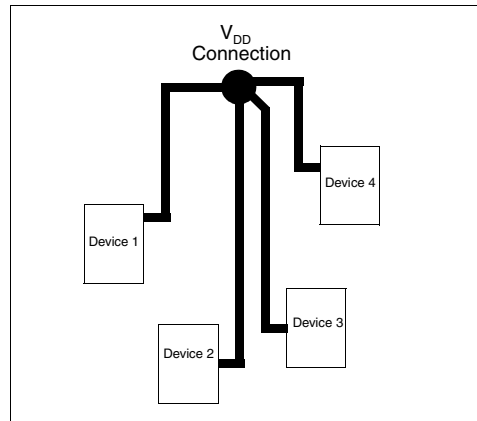
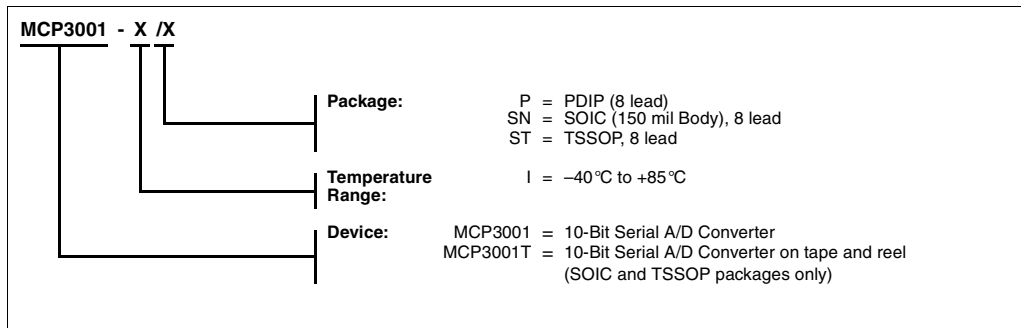

FIGURE 6-4: V_{DD} traces arranged in a 'Star' configuration in order to reduce errors caused by current return paths.

MCP3001 PRODUCT IDENTIFICATION SYSTEM

To order or obtain information, e.g., on pricing or delivery, refer to the factory or the listed sales office.



Sales and Support

Data Sheets

Products supported by a preliminary Data Sheet may have an errata sheet describing minor operational differences and recommended workarounds. To determine if an errata sheet exists for a particular device, please contact one of the following:

1. Your local Microchip sales office
2. The Microchip Corporate Literature Center U.S. FAX: (480) 786-7277
3. The Microchip Worldwide Site (www.microchip.com)

Please specify which device, revision of silicon and Data Sheet (include Literature #) you are using.

New Customer Notification System

Register on our web site (www.microchip.com/cn) to receive the most current information on our products.

MCP3001

NOTES:

NOTES:



WORLDWIDE SALES AND SERVICE

AMERICAS

Corporate Office

Microchip Technology Inc.
2355 West Chandler Blvd.
Chandler, AZ 85224-6199
Tel: 480-786-7200 Fax: 480-786-7277
Technical Support: 480-786-7627
Web Address: <http://www.microchip.com>

Atlanta

Microchip Technology Inc.
500 Sugar Mill Road, Suite 200B
Atlanta, GA 30350
Tel: 770-640-0034 Fax: 770-640-0307

Boston

Microchip Technology Inc.
5 Mount Royal Avenue
Marlborough, MA 01752
Tel: 508-480-9990 Fax: 508-480-8575

Chicago

Microchip Technology Inc.
333 Pierce Road, Suite 180
Itasca, IL 60143
Tel: 630-285-0071 Fax: 630-285-0075

Dallas

Microchip Technology Inc.
4570 Westgrove Drive, Suite 160
Addison, TX 75248
Tel: 972-818-7423 Fax: 972-818-2924

Dayton

Microchip Technology Inc.
Two Prestige Place, Suite 150
Miamisburg, OH 45342
Tel: 937-291-1654 Fax: 937-291-9175

Detroit

Microchip Technology Inc.
Tri-Atria Office Building
32255 Northwestern Highway, Suite 190
Farmington Hills, MI 48334
Tel: 248-538-2250 Fax: 248-538-2260

Los Angeles

Microchip Technology Inc.
18201 Von Karman, Suite 1090
Irvine, CA 92612
Tel: 949-263-1888 Fax: 949-263-1338

New York

Microchip Technology Inc.
150 Motor Parkway, Suite 202
Hauppauge, NY 11788
Tel: 631-273-5305 Fax: 631-273-5335

San Jose

Microchip Technology Inc.
2107 North First Street, Suite 590
San Jose, CA 95131
Tel: 408-436-7950 Fax: 408-436-7955

AMERICAS (continued)

Toronto

Microchip Technology Inc.
5925 Airport Road, Suite 200
Mississauga, Ontario L4V 1W1, Canada
Tel: 905-405-6279 Fax: 905-405-6253

ASIA/PACIFIC

Beijing

Microchip Technology, Beijing
Unit 915, 6 Chaoyangmen Bei Dajie
Dong Erhuan Road, Dongcheng District
New China Hong Kong Manhattan Building
Beijing 100027 PRC
Tel: 86-10-85282100 Fax: 86-10-85282104

Hong Kong

Microchip Asia Pacific
Unit 2101, Tower 2
Metroplaza
223 Hing Fong Road
Kwai Fong, N.T., Hong Kong
Tel: 852-2-401-1200 Fax: 852-2-401-3431

India

Microchip Technology Inc.
India Liaison Office
No. 6, Legacy, Convent Road
Bangalore 560 025, India
Tel: 91-80-229-0061 Fax: 91-80-229-0062

Japan

Microchip Technology Intl. Inc.
Benex S-1 6F
3-18-20, Shinyokohama
Kohoku-Ku, Yokohama-shi
Kanagawa 222-0033 Japan
Tel: 81-45-471-6166 Fax: 81-45-471-6122

Korea

Microchip Technology Korea
168-1, Youngbo Bldg. 3 Floor
Samsung-Dong, Kangnam-Ku
Seoul, Korea
Tel: 82-2-554-7200 Fax: 82-2-558-5934

Shanghai

Microchip Technology
Unit B701, Far East International Plaza,
No. 317, Xianxia Road
Shanghai, 200051 P.R.C.
Tel: 86-21-6275-5700 Fax: 86-21-6275-5060

ASIA/PACIFIC (continued)

Singapore

Microchip Technology Singapore Pte Ltd.
200 Middle Road
#07-02 Prime Centre
Singapore 188980
Tel: 65-334-8870 Fax: 65-334-8850

Taiwan

Microchip Technology Taiwan
10F-1C 207
Tung Hua North Road
Taipei, Taiwan
Tel: 886-2-2717-7175 Fax: 886-2-2545-0139

EUROPE

Denmark

Microchip Technology Denmark ApS
Regus Business Centre
Lautrup høj 1-3
Ballerup DK-2750 Denmark
Tel: 45 4420 9895 Fax: 45 4420 9910

France

Arizona Microchip Technology SARL
Parc d'Activite du Moulin de Massy
43 Rue du Saule Trapu
Batiment A - 1er Etage
91300 Massy, France
Tel: 33-1-69-53-63-20 Fax: 33-1-69-30-90-79

Germany

Arizona Microchip Technology GmbH
Gustav-Heinemann-Ring 125
D-81739 München, Germany
Tel: 49-89-627-144 0 Fax: 49-89-627-144-44

Italy

Arizona Microchip Technology SRL
Centro Direzionale Colleoni
Palazzo Taurus 1 V. Le Colleoni 1
20041 Agrate Brianza
Milan, Italy
Tel: 39-039-65791-1 Fax: 39-039-6899883

United Kingdom

Arizona Microchip Technology Ltd.
505 Eskdale Road
Winnersh Triangle
Wokingham
Berkshire, England RG41 5TU
Tel: 44 118 921 5858 Fax: 44-118 921-5835

01/21/00

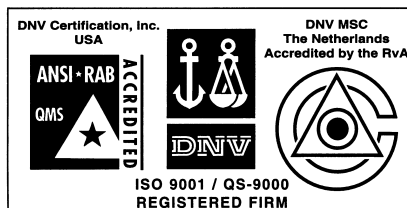

Microchip received QS-9000 quality system certification for its worldwide headquarters, design and wafer fabrication facilities in Chandler and Tempe, Arizona in July 1999. The Company's quality system processes and procedures are QS-9000 compliant for its PICmicro® 8-bit MCUs, KEELOC® code hopping devices, Serial EEPROMs and microperipheral products. In addition, Microchip's quality system for the design and manufacture of development systems is ISO 9001 certified.

All rights reserved. © 2000 Microchip Technology Incorporated. Printed in the USA. 3/00 Printed on recycled paper.

Information contained in this publication regarding device applications and the like is intended through suggestion only and may be superseded by updates. It is your responsibility to ensure that your application meets with your specifications. No representation or warranty is given and no liability is assumed by Microchip Technology Incorporated with respect to the accuracy or use of such information, or infringement of patents or other intellectual property rights arising from such use or otherwise. Use of Microchip's products as critical components in life support systems is not authorized except with express written approval by Microchip. No licenses are conveyed, implicitly or otherwise, except as maybe explicitly expressed herein, under any intellectual property rights. The Microchip logo and name are registered trademarks of Microchip Technology Inc. in the U.S.A. and other countries. All rights reserved. All other trademarks mentioned herein are the property of their respective companies.

© 2000 Microchip Technology Inc.