

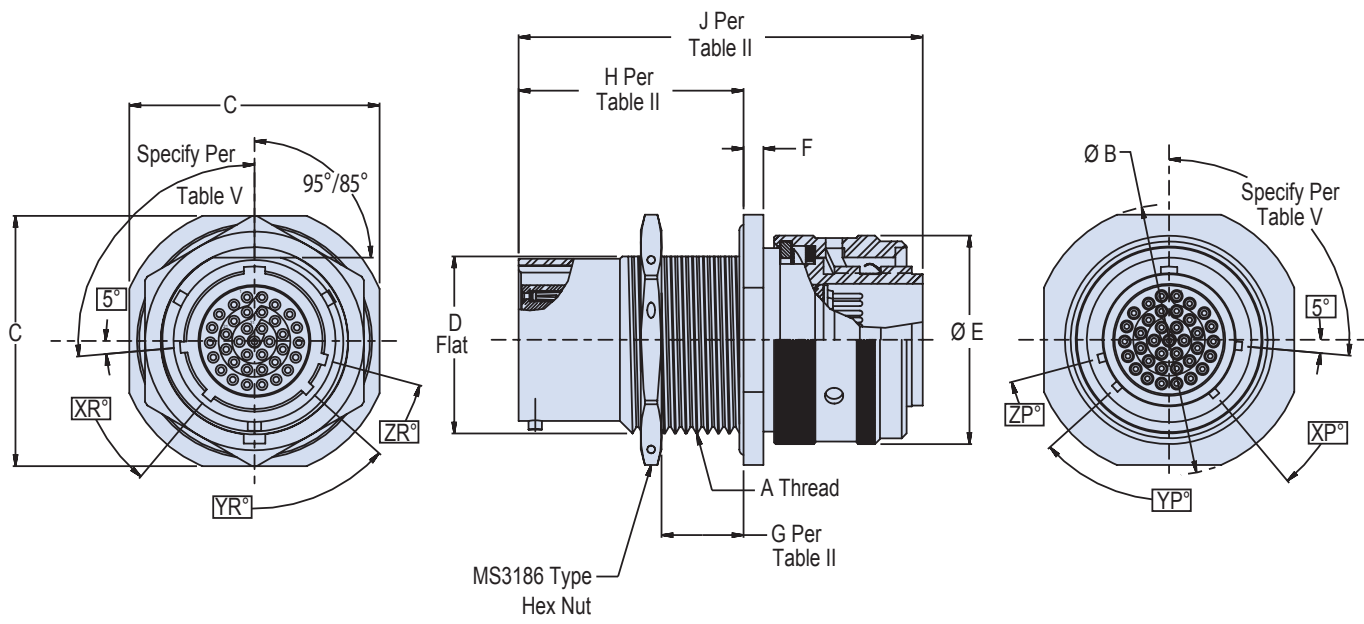

231-103-H9
Sav-Con® Jam Nut Mount Hermetic Bulkhead Feed-Thru
MIL-DTL-38999 Series I Type

B

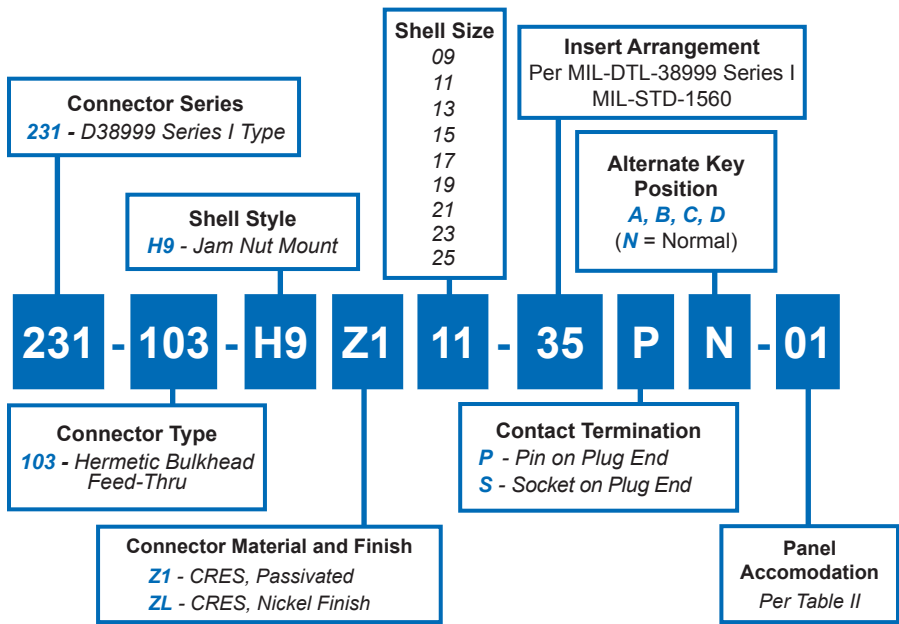

Dimensions in Inches (millimeters) are subject to change without notice.

231-103-H9
Sav-Con® Jam Nut Mount Hermetic Bulkhead Feed-Thru
MIL-DTL-38999 Series I Type



TABLE I: CONNECTOR DIMENSIONS

SHELL SIZE	A THREAD CLASS 2A	B DIA MAX	C A/F	D FLAT	E DIA MAX	F	K DIA	N
9	.6875-24 UNEF	1.204/1.172 (30.58/29.77)	1.078/1.046 (27.38/26.57)	.655/.645 (16.64/16.38)	.859 (21.82)	.125/.093 (3.18/2.36)	.703/.693 (17.86/17.60)	.657/.655 (16.69/16.64)
11	.8125-20 UNEF	1.391/1.359 (35.33/34.52)	1.299/1.234 (32.99/31.34)	.755/.745 (19.18/18.92)	.984 (24.99)	.125/.093 (3.18/2.36)	.835/.825 (21.21/20.96)	.771/.769 (19.58/19.53)
13	1.000-20 UNEF	1.516/1.484 (38.51/37.69)	1.391/1.359 (35.33/34.52)	.942/.932 (23.93/23.67)	1.156 (29.36)	.125/.093 (3.18/2.36)	1.020/1.010 (25.91/25.65)	.955/.953 (24.26/24.21)
15	1.125-18 UNEF	1.641/1.609 (41.68/40.87)	1.516/1.484 (38.51/37.69)	1.066/1.056 (27.08/26.82)	1.281 (32.54)	.125/.093 (3.18/2.36)	1.145/1.135 (29.08/28.83)	1.085/1.083 (27.56/27.51)
17	1.250-18 UNEF	1.766/1.734 (44.86/44.04)	1.641/1.609 (41.68/40.87)	1.191/1.181 (30.35/30.00)	1.406 (35.71)	.125/.093 (3.18/2.36)	1.270/1.260 (32.26/32.00)	1.210/1.208 (30.73/30.68)
19	1.375-18 UNEF	1.954/1.922 (49.63/48.82)	1.828/1.796 (46.43/45.62)	1.316/1.306 (33.43/33.17)	1.516 (38.5)	.156/.124 (3.96/3.15)	1.395/1.385 (35.43/35.18)	1.335/1.333 (33.91/33.86)
21	1.500-18 UNEF	2.078/2.046 (52.78/51.97)	1.954/1.922 (49.63/48.82)	1.441/1.431 (36.60/36.35)	1.641 (41.68)	.156/.124 (3.96/3.15)	1.520/1.510 (38.61/38.35)	1.460/1.458 (37.08/37.03)
23	1.625-18 UNEF	2.204/2.172 (55.98/55.17)	2.078/2.046 (52.78/51.97)	1.566/1.556 (39.78/39.52)	1.766 (44.86)	.156/.124 (3.96/3.15)	1.645/1.635 (41.8/41.53)	1.585/1.583 (40.26/40.21)
25	1.750-18 UNS	2.328/2.296 (59.13/58.32)	2.204/2.172 (55.98/55.17)	1.691/1.681 (42.95/42.70)	1.891 (48.03)	.156/.124 (3.96/3.15)	1.770/1.760 (44.96/44.70)	1.710/1.708 (43.43/43.38)

TABLE IV: MASTER KEY/KEYWAY POSITIONS

SHELL SIZE	XP YP	YP YR	ZP ZR	N	A	B	C	D
9	45°	88°	27°	95°	77°	—	—	113°
11	45°	88°	27°	95°	81°	67°	123°	109°
13	45°	88°	27°	95°	75°	63°	127°	115°
15	45°	88°	27°	95°	74°	61°	129°	116°
17	45°	88°	27°	95°	77°	65°	125°	113°
19	45°	88°	27°	95°	77°	65°	125°	113°
21	45°	88°	27°	95°	77°	65°	125°	113°
23	45°	88°	27°	95°	80°	69°	121°	110°
25	45°	.88°	27°	95°	80°	69°	121°	110°

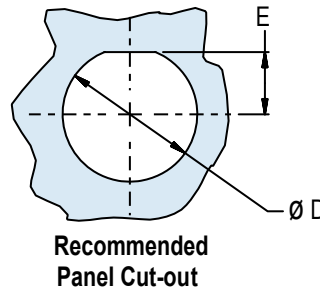

TABLE III: DWV VOLTAGE LEVELS

SERVICE RATING	VOLTAGE AC RMS 60HZ
M	1300 VAC
I	1800 VAC
II	2300 VAC
N	1000 VAC

HERMETIC LEAK RATE MOD CODES

Designator	Required Leak Rate
-585A	1 x 10 ⁻¹⁰ cc Helium per second
-585B	1 x 10 ⁻⁹ cc Helium per second
-585C	1 x 10 ⁻⁸ cc Helium per second

TABLE II: DIMENSIONS

SYM	G	H	J
01	.062-.125 (1.57-3.18)	.920 MAX (23.37 MAX)	2.050 MAX (52.07 MAX)
02	.062-.250 (1.57-6.35)	1.050 MAX (26.67 MAX)	2.150 MAX (54.61 MAX)
03	.062-.500 (1.57-12.7)	1.300 MAX (33.02 MAX)	2.400 MAX (60.96 MAX)

APPLICATION NOTES

- Material/finish:
Shell, jam-nut – 300 Series CRES/see P/N development.
Contacts, pin – Nickel-iron alloy/Gold plate.
Contacts, socket – Copper alloy/Gold plate.
Insulator, pin – Vitreous glass/N.A.
Insulator, sockets – HI-grade rigid dielectric/N.A.
Grounding springs – Copper alloy/Gold plate.
O-Rings and seals – Fluorosilicone blend/N.A.
- Assembly identified with manufacturer's name and part number, space permitting.
- Test requirements:
D.W.V. – Per Table IV
I.R. – 5 GigOhms @ 500 VDC
Hermeticity – <1 x 10⁻⁷ sccHe/sec @ 1 ATM differential.
- Metric dimensions (mm) are indicated in parentheses.

Dimensions in Inches (millimeters) are subject to change without notice.