



# Series 8XXX Collet Elevator Socket on 0.300 [7.62] and 0.600 [15.24] Centers

## FEATURES

- Ideal for elevating devices (displays, switches, etc.) to desired level with .240 to 1.250 [6.10 to 31.75] height extension.

## GENERAL SPECIFICATIONS

- STANDARD SOCKET BODY: Spacer black UL 94V-0 glass-filled 4/6 Nylon
- PIN BODY: Brass 360 1/2-hard per UNS C36000 ASTM B16/B16M-05
- PIN BODY PLATING: either 10 $\mu$  [0.25 $\mu$ ] min. Au per MIL-G-45204 or 200 $\mu$  [5.08] min. 93/7 Sn/Pb per ASTM B545 or 200 $\mu$  [5.08 $\mu$ ] min. Sn per ASTM B545 Type 1 over 100 $\mu$  [2.54 $\mu$ ] min. Ni per SAE AMS-QQ-N-290B
- 4-FINGER COLLET CONTACT: BeCu per UNS C17200 ASTM B194-08
- CONTACT PLATING: 30 $\mu$  [0.76 $\mu$ ] min. Au per MIL-G-45204 over 50 $\mu$  [1.27 $\mu$ ] min. Ni per SAE AMS-QQ-N-290B
- CONTACT CURRENT RATING: 3 amps
- OPERATING TEMPERATURE: -67°F to 221°F [-55°C to 105°C]
- INSERTION FORCE: 180g/pin, based on 0.018 [0.46] dia. test lead
- WITHDRAWAL FORCE: 90g/pin, based on 0.018 [0.46] dia. test lead
- NORMAL FORCE: 140g/pin, based on 0.018 [0.46] dia. test lead
- ACCEPTS LEADS: 0.015-0.025 [0.38-0.64] dia., 0.110-0.150 [2.79-3.81] long

## MOUNTING CONSIDERATIONS

- SUGGESTED PCB HOLE SIZE: 0.035  $\pm$  0.002 [0.89  $\pm$  0.05] dia.

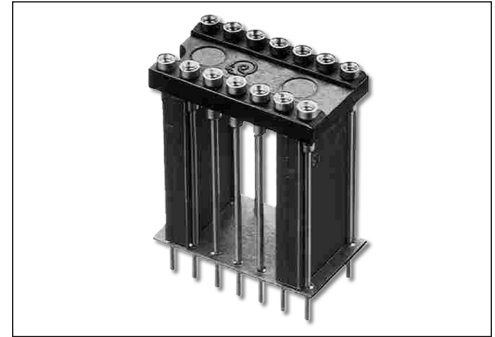

**CUSTOMIZATION:** In addition to the standard products shown on this page, Aries specializes in custom design and production. Special materials, platings, sizes, and configurations can be furnished, depending on the quantity. **NOTE:** Aries reserves the right to change product general specifications without notice.

## ORDERING INFORMATION

**XX-8 XXXX-X 10 C XX**

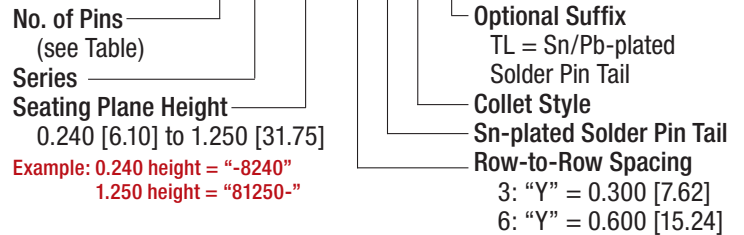

Centers "Y"	Dim. "Z"	Body Style	Available Sizes
0.300 [7.62]	0.400 [10.16]	C	6 thru 20
		B	22 thru 40
0.600 [15.24]	0.700 [17.78]	C	6 thru 40
		B	42 thru 48

ALL DIMENSIONS IN INCHES [MILLIMETERS]  
CONSULT FACTORY FOR NON-STANDARD SIZES  
ALL TOLERANCES  $\pm$ 0.005 [ $\pm$ 0.13] UNLESS OTHERWISE SPECIFIED  
"W" # PINS PER ROW x 0.100 [2.54]  
"X" (# PINS PER ROW -1) x 0.100 [2.54]

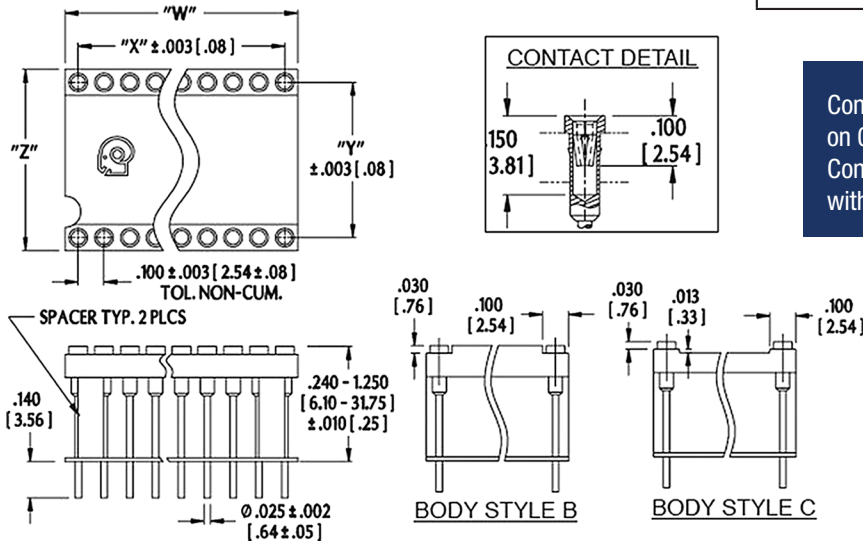

Consult [Data Sheet 13007](#) for Collet Elevator Sockets on 0.200 [5.08] centers.  
Consult [Data Sheet 13006](#) for Elevator Sockets with Bifurcated contacts.



Bristol, PA 19007-6810 USA  
TEL (215) 781-9956 • FAX (215) 781-9845  
WWW.ARIESELEC.COM • INFO@ARIESELEC.COM

