



# NJG1312PC1

## ■ ABSOLUTE MAXIMUM RATINGS

( $T_a=+25^{\circ}\text{C}$ ,  $Z_s=Z_l=50\Omega$ )

PARAMETER	SYMBOL	CONDITIONS	RATINGS	UNITS
Drain Voltage	$V_{DD}$		6	V
Control Voltage	$V_{CTL}$		6	V
Input Power	$P_{in}$	$V_{DD}=2.9\text{V}$	15	dBm
Power Dissipation	$P_D$		400	mW
Operating Temperature	$T_{opr}$		-40~+85	$^{\circ}\text{C}$
Storage Temperature	$T_{stg}$		-55~+125	$^{\circ}\text{C}$

## ■ ELECTRICAL CHARACTERISTICS

( $V_{DD}=2.9\text{V}$ ,  $V_{CTR}=2.7\text{V}$ ,  $f=900\text{MHz}$ ,  $T_a=-20\sim+80^{\circ}\text{C}$ ,  $Z_s=Z_l=50\Omega$ ,  $R_s$  (External)=180 $\Omega$ )

PARAMETER	SYMBOL	CONDITIONS	MIN	TYP	MAX	UNITS
Operating Frequency	Freq		887	900	925	MHz
Drain Voltage	$V_{DD}$		2.7	2.9	5.0	V
Operating Current	$I_{DD}$	RF SW ON $P_{out}=+5.6\text{dBm}$	-	17	22	mA
Control Current	$I_{CTL}$		-	1.0	2.0	$\mu\text{A}$
Control Voltage(LOW)	$V_{CTL(L)}$		-0.2	0	0.2	V
Control Voltage(HIGH)	$V_{CTL(H)}$		2.5	2.7	5.5	V
Small Signal Gain	Gain	RF SW ON $P_{in}=-15\text{dBm}$	17	19	22	dB
Gain Flatness	$G_{flat}$	RF SW ON $P_{in}=-15\text{dBm}$ $f=887\sim 925\text{MHz}$	-	0.5	-	dB
Gain Control Range	$G_{cont}$	$P_{in}=-15\text{dBm}$	-28.5	-27	-25.5	dB
Pout at 1dB Gain Compression point	$P_{-1dB}$	RF SW ON	-	+10	-	dBm
IN-Band Spurious1	IBS1	RF SW ON, $P_{out}=+5.6\text{dBm}$ OFFSET 900kHz	-	-55	-51	dBc
IN-Band Spurious2	IBS2	RF SW ON, $P_{out}=+5.6\text{dBm}$ OFFSET 1.98MHz	-	-73	-68	dBc
Input VSWR	$VSWR_i$	RF SW ON	-	2.4	3.0	
Output VSWR	$VSWR_o$	RF SW ON	-	1.4	2.0	

Note) RF SW ON/OFF in the table above: Control voltages ( $V_{CTL1}$ ,  $V_{CTL2}$ ) are as follows

RF SW ON	P1: $V_{CTL1}=0\text{V}$ , $V_{CTL2}=2.7\text{V}$
	P2: $V_{CTL1}=2.7\text{V}$ , $V_{CTL2}=0\text{V}$
RF SW OFF	P1: $V_{CTL1}=2.7\text{V}$ , $V_{CTL2}=0\text{V}$
	P2: $V_{CTL1}=0\text{V}$ , $V_{CTL2}=2.7\text{V}$

## ■ TERMINAL INFORMATION

No.	SYMBOL	DESCRIPTIONS
1	PC	RF output terminal of SW.
2	GND	Ground terminal.
3	GND	Ground terminal.
4	RF <sub>in</sub>	RF signal input terminal of driver amplifier.
5	NC	Neutral terminal. Should be connected to the ground.
6	GND	Ground terminal.
7	GND	Ground terminal.
8	BPC	Source electrode terminal of driver amplifier. The operating current is chosen by a resistor connected between this terminal and ground.
9	RF <sub>out</sub>	RF signal output terminal of driver amplifier. Please use choke coil for power supply of driver amplifier at this terminal.
10	GND	Ground terminal.
11	P2	RF input terminal 2 of SW.
12	V <sub>CTL2</sub>	Control terminal 2 of RF signal. Please see the truth table.
13	V <sub>CTL1</sub>	Control terminal 1 of RF signal. Please see the truth table.
14	P1	RF input terminal 1 of SW.
15	GND	Ground terminal.
16	GND	Ground terminal.

Notice: PC terminal at pin 1 should be connected to the GND through high resistance for pull-down (Max 560kΩ).

## ■ TRUTH TABLE

V <sub>CTL1</sub>	V <sub>CTL2</sub>	P1-PC	P2-PC
0V	2.7V	ON	OFF
2.7V	0V	OFF	ON

# NJG1312PC1

## TYPICAL CHARACTERISTICS

### FREQUENCY CHARACTERISTICS

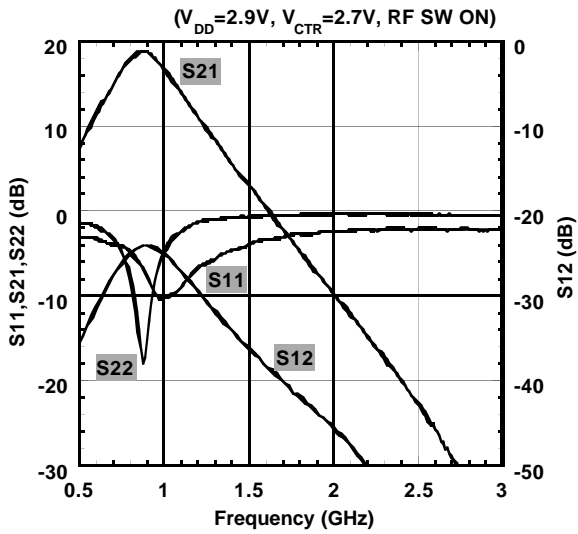

### FREQUENCY CHARACTERISTICS

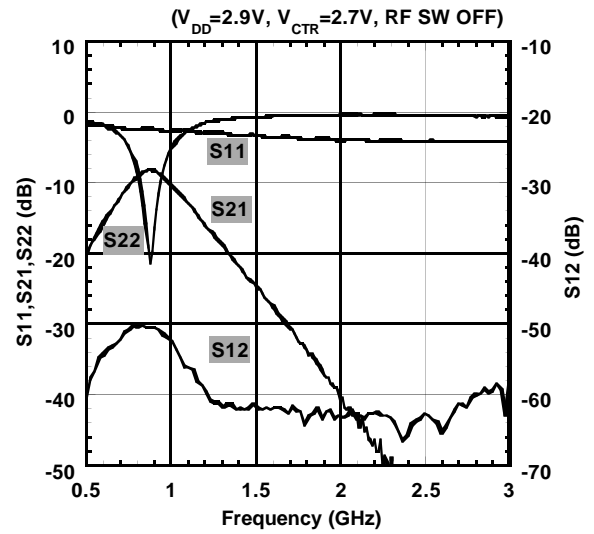

### Pin vs. Pout, $I_{DD}$

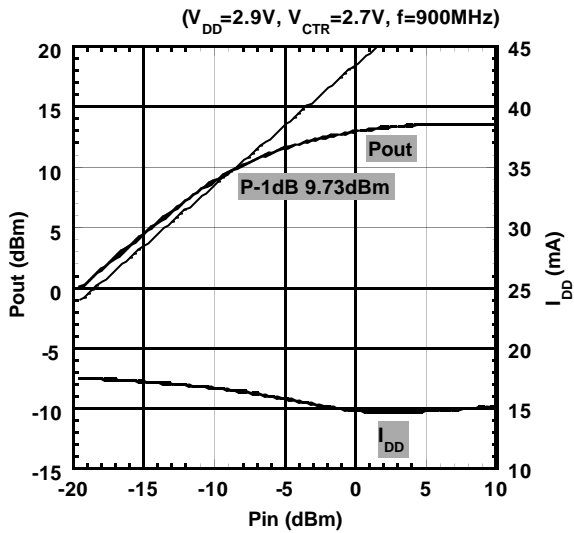

### $I_{DD}, I_{CTR}$ vs. TEMPERATURE

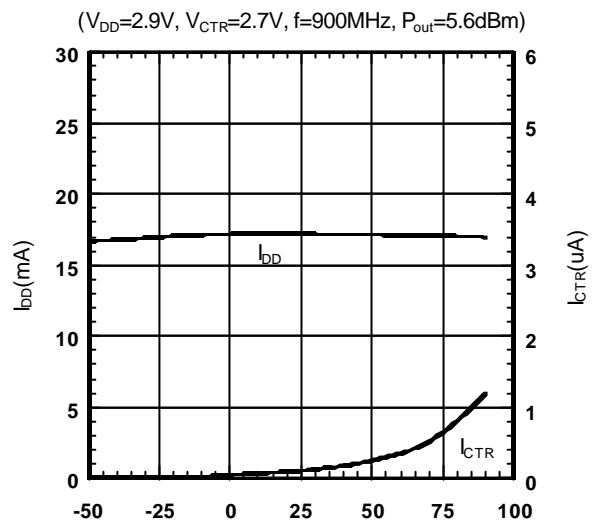

### Gain, $G_{cont}$ , $G_{flat}$ vs. TEMPERATURE

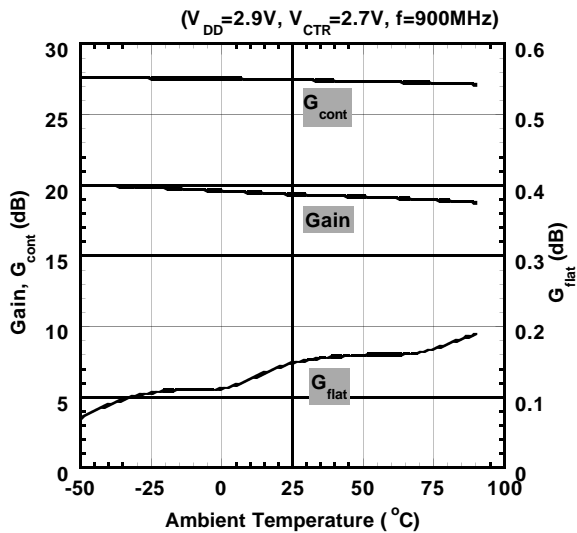

### P-1dB, Psat, IN BAND SPURIOUS vs. TEMPERATURE

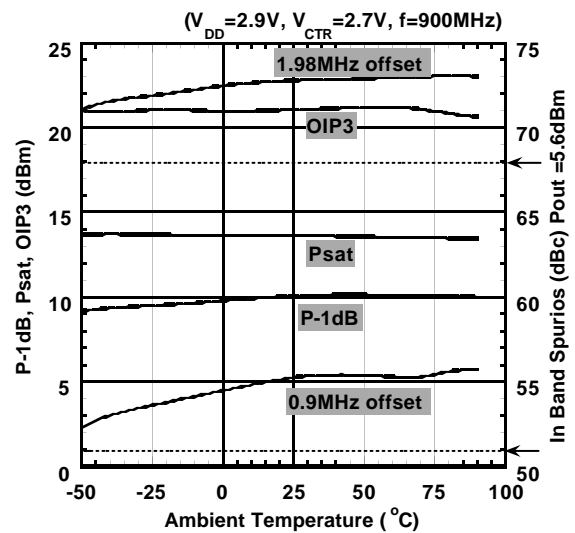

## TYPICAL CHARACTERISTICS

Driver Amp. Scattering Parameters Table ( $V_{DD}=2.9V$ ,  $R_s=180\Omega$ ,  $Z_0=50\Omega$ )

Freq. (GHz)	S 11		S 21		S 12		S 22	
	mag (U)	ang (deg)	mag (U)	ang (deg)	mag (U)	ang (deg)	mag (U)	ang (deg)
0.50	0.902	-20.1	4.427	-177.6	0.036	53.9	0.763	-47.8
0.60	0.907	-25.8	4.762	172.6	0.040	49.6	0.757	-56.9
0.70	0.901	-31.2	4.897	164.1	0.044	45.4	0.699	-63.4
0.80	0.896	-36.8	5.018	155.4	0.048	41.9	0.701	-70.6
0.90	0.880	-41.9	4.992	147.8	0.051	37.6	0.667	-77.0
1.00	0.864	-46.9	5.006	140.2	0.053	35.0	0.660	-83.2
1.10	0.839	-52.0	4.891	133.3	0.055	32.6	0.651	-88.6
1.20	0.824	-56.6	4.837	126.4	0.058	28.1	0.636	-94.7
1.30	0.797	-61.1	4.675	120.3	0.061	27.1	0.642	-99.9
1.40	0.779	-65.6	4.580	113.7	0.061	22.8	0.636	-105.8
1.50	0.754	-69.6	4.428	108.0	0.063	21.4	0.640	-110.2
1.60	0.737	-73.8	4.301	102.0	0.064	19.0	0.640	-115.1
1.70	0.715	-77.4	4.122	96.9	0.064	15.3	0.640	-119.4
1.80	0.696	-81.3	3.973	91.6	0.067	13.3	0.643	-123.5
1.90	0.676	-84.5	3.800	86.3	0.066	10.4	0.644	-127.8
2.00	0.663	-88.0	3.653	81.2	0.067	7.8	0.648	-131.7
2.10	0.644	-90.8	3.478	76.5	0.068	6.2	0.651	-135.3
2.20	0.628	-93.9	3.334	71.9	0.068	3.9	0.659	-139.5
2.30	0.617	-96.3	3.163	67.3	0.069	1.7	0.662	-143.0
2.40	0.603	-98.9	3.016	62.7	0.069	-1.3	0.676	-147.1
2.50	0.594	-101.0	2.850	58.3	0.069	-3.5	0.683	-150.9
2.60	0.582	-102.9	2.702	54.1	0.070	-6.6	0.697	-154.6
2.70	0.577	-104.6	2.546	50.0	0.070	-10.5	0.706	-158.4
2.80	0.574	-106.1	2.389	46.3	0.069	-13.1	0.722	-161.9
2.90	0.577	-107.3	2.234	42.6	0.069	-17.0	0.733	-165.5
3.00	0.580	-108.4	2.069	39.6	0.066	-21.0	0.747	-168.9

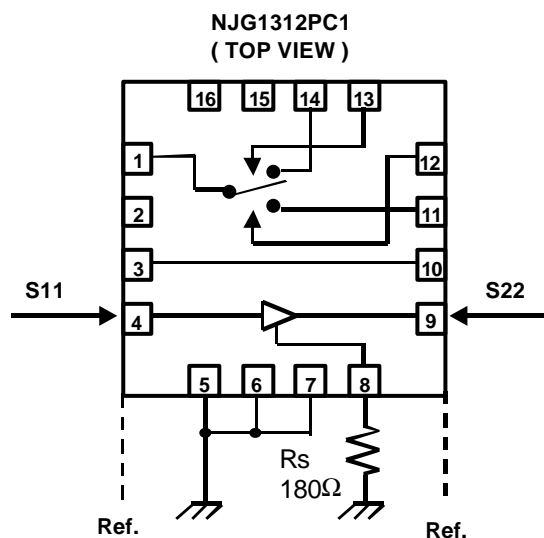

Driver Amp. Scattering Parameters

# NJG1312PC1

## APPLICATION CIRCUIT

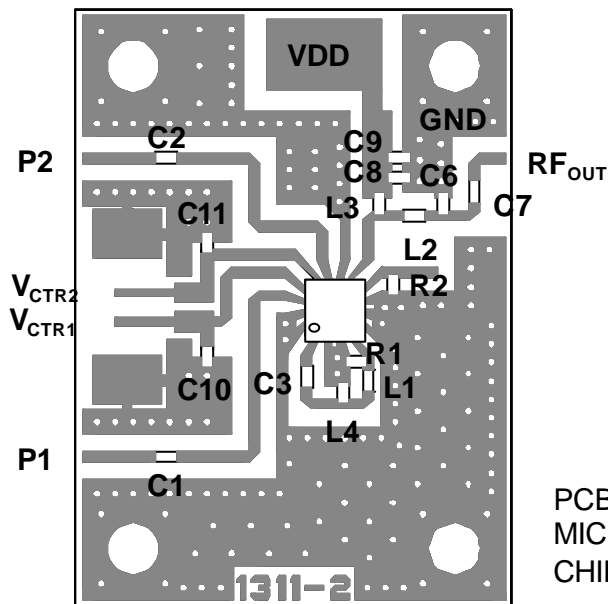
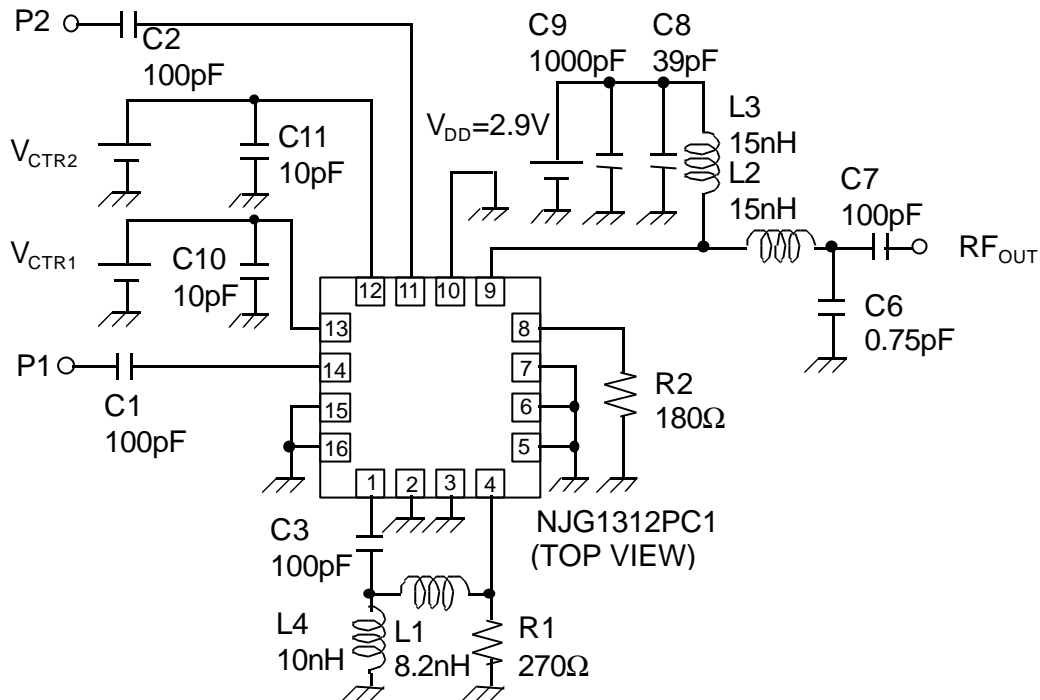

PCB: FR-4 19.0x26.0mm, t=0.2mm  
 MICROSTRIP LINE WIDTH=0.4mm ( $Z_0=50\Omega$ )  
 CHIP SIZE:1005

### [1] Chip parts list

Parts ID	Comment
C1~C11	MURATA GRM36 Series
L1~L4	TAIYO-YUDEN HK1005 Series

## PACKAGE OUTLINE (FFP16-C1)

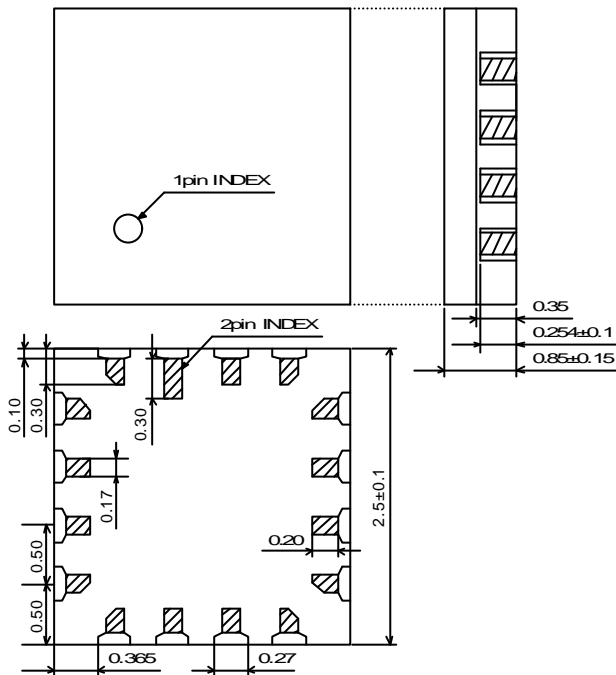

UNIT	: mm
PCB	: Ceramic
OVER COAT	: Epoxy resin
TERMINAL TREAT	: Au
WEIGHT	: 15mg

### Cautions on using this product

This product contains Gallium-Arsenide (GaAs) which is a harmful material.

- Do NOT eat or put into mouth.
- Do NOT dispose in fire or break up this product.
- Do NOT chemically make gas or powder with this product.
- To waste this product, please obey the relating law of your country.

### [CAUTION]

The specifications on this databook are only given for information, without any guarantee as regards either mistakes or omissions. The application circuits in this databook are described only to show representative usages of the product and not intended for the guarantee or permission of any right including the industrial rights.

This product may be damaged with electric static discharge (ESD) or spike voltage. Please handle with care to avoid these damages.