











Opto-Electronic Devices

Numeric LED Displays

ECG Type	Description	Color	Digit Des.	Current Per Segment (mA)	Reverse Voltage Per Segment (V)	Power Diss. Pt (mW)	Fig. No.
ECG3050	.270"; Com Anode; LHDP	Red		30	10	750	P30
ECG3051	.270"; Com Anode; Polarity/Overflow	Red		30	10	480	P31
ECG3052	.3"; Com Anode; RHDP	Red		30	5	700	P32
ECG3053		Orange		20	3	400	
ECG3054		Green		20	3	400	
ECG3055		Yellow		20	3	400	
ECG3056	.3"; Com Cathode; RHDP	Red		30	5	700	P32
ECG3057		Red		25	3	700	
ECG3058		Orange		20	3	400	
ECG3059		Green		20	3	400	
ECG3060		Yellow		20	3	400	
ECG3061	.3"; Com Anode; LHDP	Red		30	5	700	P33
ECG3062		Orange		20	3	400	
ECG3063		Green		20	3	400	
ECG3064		Yellow		20	3	400	
ECG3065	.3"; Com Anode; Polarity/Overflow	Red		30	5	350	P34
ECG3068	.4"; Com Anode; RHDP	Red		30	5	700	P35
ECG3069	.4"; Com Cathode; RHDP	Red		30	5	700	P36
ECG3070	.4"; Com Anode; RHDP	Orange		20	5	400	P35
ECG3071	.4"; Com Cathode; RHDP	Orange		20	5	400	P36
ECG3074	.560"; Com Anode; RHDP; 2-Digit	Red		20	5	800	P37
ECG3075	.560"; Com Cathode; RHDP; 2-Digit	Red		20	5	800	
ECG3076	.560"; Com Anode; RHDP; 1-1/2 Digit	Red		20	5	650	P38
ECG3077	.560"; Com Cathode; RHDP; 1-1/2 Digit	Red		20	5	650	
ECG3078	.560"; Com Anode; RHDP	Red		20	5	400	P39
ECG3079	.560"; Com Cathode; RHDP	Red		20	5	400	
ECG3080	.8"; Com Anode; RHDP	Red		20	3	400	

LHDP - Left Hand Decimal Point
RHDP - Right Hand Decimal Point

Numeric LED Display Outlines

Fig. P30

ECG3050 - Red

1. A - Cathode
2. F - Cathode
3. Common Anode
4. No Pin
5. No Pin
6. Dec Pt Cathode
7. E - Cathode
8. D - Cathode
9. Common Anode
10. C - Cathode
11. G - Cathode
12. No Pin
13. B - Cathode
14. Common Anode

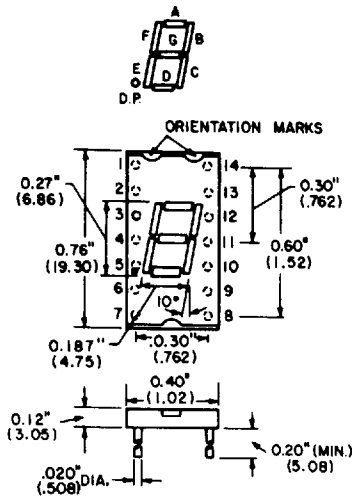

Fig. P31

ECG3051 - Red

1. Anode Common C/D
2. No Connection
3. No Connection
4. No Connection
5. No Connection
6. No Connection
7. D - Cathode
8. C - Cathode
9. No Connection
10. B - Cathode
11. A - Cathode
12. No Connection
13. No Connection
14. Anode Common A/B

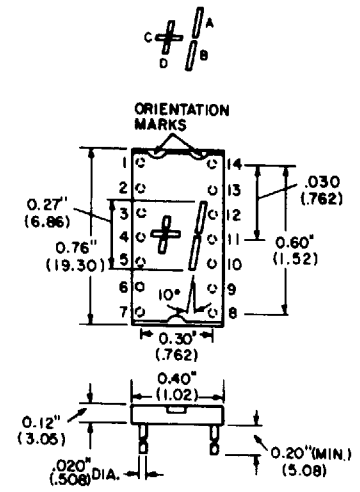

Fig. P32

**ECG3052 - Red
ECG3053 - Orn
ECG3054 - Grn
ECG3055 - Yel**

1. A - Cathode
2. F - Anode
3. Common Anode
4. No Pin
5. No Pin
6. No Connection
7. E - Cathode
8. D - Cathode
9. Dec Pt Cathode
10. C - Cathode
11. G - Cathode
12. No Pin
13. B - Cathode
14. Common Anode

**ECG3056 - Red
ECG3058 - Orn
ECG3059 - Grn
ECG3060 - Yel**

1. F - Anode
2. G - Anode
3. No Pin
4. Common Cathode
5. No Pin
6. E - Anode
7. D - Anode
8. C - Anode
9. Common Cathode
10. No Pin
11. No Pin
12. Common Cathode
13. B - Anode
14. A - Anode

ECG3057 - Red

1. No Pin
2. Common Cathode
3. F - Anode
4. G - Anode
5. E - Anode
6. D - Anode
7. No Pin
8. No Pin
9. Common Cathode
10. Dec Pt Anode
11. C - Anode
12. B - Anode
13. A - Anode
14. No Pin

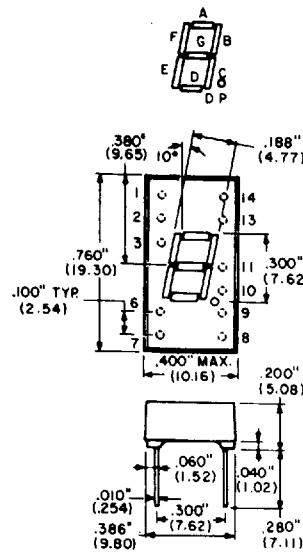

Fig. P33

**ECG3061 - Red
ECG3062 - Orn
ECG3063 - Grn
ECG3064 - Yel**

1. A - Cathode
2. F - Cathode
3. Common Anode
4. No Pin
5. No Pin
6. Dec Pt Cathode
7. E - Cathode
8. D - Cathode
9. No Connection
10. C - Cathode
11. G - Cathode
12. No Pin
13. B - Cathode
14. Common Anode

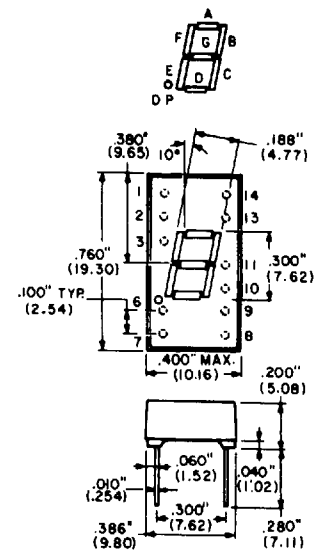

Fig. P34

ECG3065 - Red

1. Common Anode C/D
2. No Pin
3. Common Anode C/D
4. No Pin
5. No Pin
6. No Pin
7. D - Cathode
8. C - Cathode
9. No Connection
10. B - Cathode
11. A - Cathode
12. No Pin
13. No Pin
14. Common Anode A/B

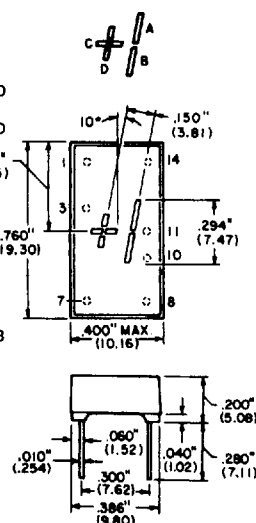

Fig. P35

**ECG3068 - Red
ECG3070 - Orn**

1. A - Cathode
2. F - Cathode
3. Common Anode
4. No Pin
5. No Pin
6. No Connection
7. E - Cathode
8. D - Cathode
9. Dec Pt Cathode
10. C - Cathode
11. G - Cathode
12. No Pin
13. B - Cathode
14. Common Anode

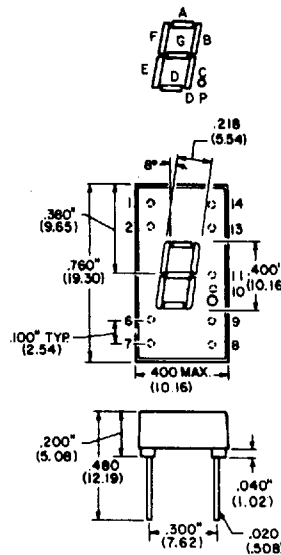
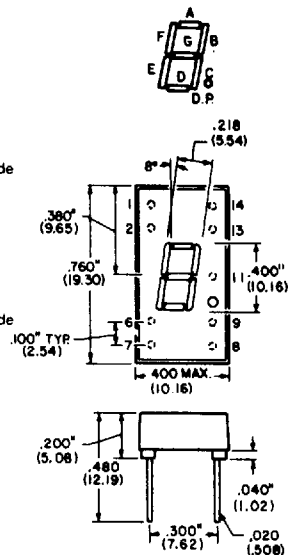

Fig. P36

**ECG3069 - Red
ECG3071 - Orn**

1. F - Anode
2. G - Anode
3. No Pin
4. Common Cathode
5. No Pin
6. E - Anode
7. D - Anode
8. C - Anode
9. Dec Pt Anode
10. No Pin
11. No Pin
12. Common Cathode
13. B - Anode
14. A - Anode



Numeric LED Display Outlines (cont'd)

Fig. P37

ECG3074 - Red

1. E - Cathode - 1
2. D - Cathode - 1
3. C - Cathode - 1
4. Dec Pt Cathode - 1
5. E - Cathode - 2
6. D - Cathode - 2
7. G - Cathode - 2
8. C - Cathode - 2
9. Dec Pt Cathode - 2
10. B - Cathode - 2
11. A - Cathode - 2
12. F - Cathode - 2
13. Common Anode - 2
14. Common Anode - 1
15. B - Cathode - 1
16. A - Cathode - 1
17. G - Cathode - 1
18. F - Cathode - 1

ECG3075 - Red

1. E - Anode - 1
2. D - Anode - 1
3. C - Anode - 1
4. Dec Pt Anode - 1
5. E - Anode - 2
6. D - Anode - 2
7. G - Anode - 2
8. C - Anode - 2
9. Dec Pt Anode - 2
10. B - Anode - 2
11. A - Anode - 2
12. F - Anode - 2
13. Common Cathode - 2
14. Common Cathode - 1
15. B - Anode - 1
16. A - Anode - 1
17. G - Anode - 1
18. F - Anode - 1

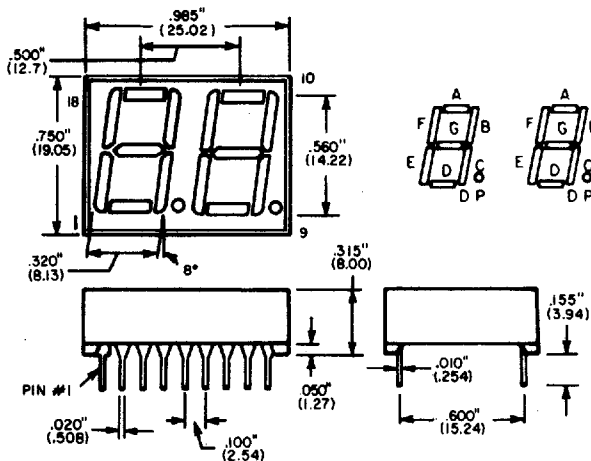

Fig. P38

ECG3076 - Red

1. C - Cathode - 1
2. D - Cathode - 1
3. B - Cathode - 1
4. Dec Pt Cathode - 1
5. E - Cathode - 2
6. D - Cathode - 2
7. G - Cathode - 2
8. C - Cathode - 2
9. Dec Pt Cathode - 2
10. B - Cathode - 2
11. A - Cathode - 2
12. F - Cathode - 2
13. Common Anode - 2
14. Common Anode - 1
15. A - Cathode - 1
16. No Connection
17. No Connection
18. No Connection

ECG3077 - Red

1. C - Anode - 1
2. D - Anode - 1
3. B - Anode - 1
4. Dec Pt Anode - 1
5. E - Anode - 2
6. D - Anode - 2
7. G - Anode - 2
8. C - Anode - 2
9. Dec Pt Anode - 2
10. B - Anode - 2
11. A - Anode - 2
12. F - Anode - 2
13. Common Cathode - 2
14. Common Cathode - 1
15. A - Anode - 1
16. No Connection
17. No Connection
18. No Connection

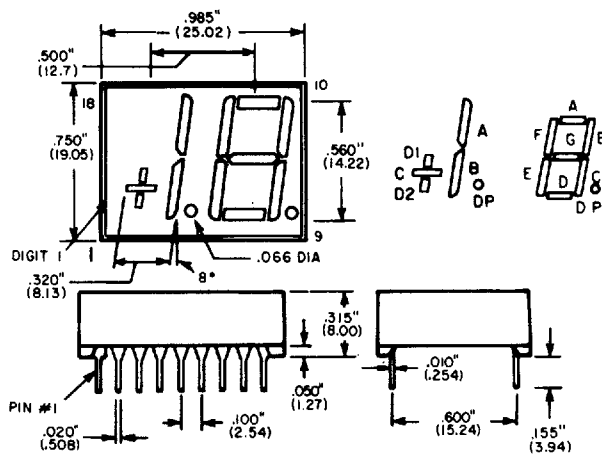

Fig. P39

ECG3078 - Red

1. E - Cathode
2. D - Cathode
3. Common Anode
4. C - Cathode
5. Dec Pt Cathode
6. B - Cathode
7. A - Cathode
8. Common Anode
9. F - Cathode
10. G - Cathode

ECG3079 - Red

1. E - Anode
2. D - Anode
3. Common Cathode
4. C - Anode
5. Dec Pt Anode
6. B - Anode
7. A - Anode
8. Common Cathode
9. F - Anode
10. G - Anode

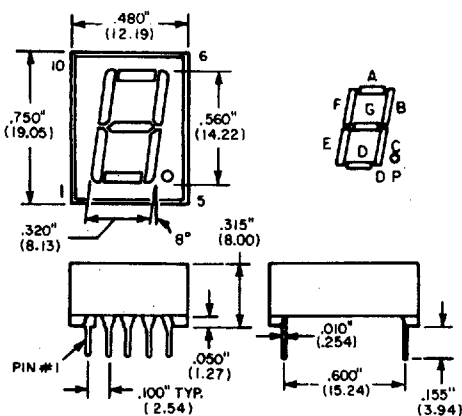

Fig. P40

ECG3080 - Red

1. No Pin
2. Segment A
3. Segment F
4. Common Anode
5. Segment E
6. Common Anode
7. No Connection
8. No Pin
9. No Pin
10. Decimal Point
11. Segment D
12. Common Anode
13. Segment C
14. Segment G
15. Segment B
16. No Pin
17. Common Anode
18. No Pin

