

Helping Customers Innovate, Improve & Grow



VX-507

### Features

- Frequency Range: 1 MHz to 800 MHz
- 9x14 J-Leaded Surface Mount Package
- AC MOS, LVPECL
- Shock and Vibration Resistance
- Military Temperature Range Option
- No pure tin is used in this product
- ECCN: EAR99
- COO: USA

### Applications

- Mobile Data Communications
- Military Portable Radio
- Satellite Communications
- Airborne Equipment
- Avionics
- Marine/Land Seismic

### Performance Specifications

Parameter	Min	Typ	Max	Units	Condition
<b>Frequency Stabilities<sup>1</sup></b>					
vs. operating temperature range (absolute pull range)					0...70°C -40...+85°C -55...+125°C
vs. supply voltage change	-2		+2	ppm	V <sub>s</sub> ± 5%
vs. load change	-1		+1	ppm	Load ± 5%
vs aging / 1 year	-5	±3	+5	ppm	
vs aging / year (following years)	-1		+1	ppm	
<b>Supply Voltage (V<sub>s</sub>)</b>					
Supply voltage	4.75	5.0	5.25	VDC	
Current consumption			15 20 40 100	mA mA mA mA	ACMOS 1 to 23.9 MHz ACMOS 24 to 49.9 MHz ACMOS 50 to 80.0 MHz LVPECL No load
Supply voltage	3.135	3.3	3.465	VDC	
Current consumption			6 8 12 16 60 100	mA mA mA mA mA mA	ACMOS 1.0 to 14.90 MHz ACMOS 15.0 TO 39.9 MHz ACMOS 40.0 TO 59.9 MHz ACMOS 60.0 TO 79.9 MHz ACMOS 80.0 to 125.0 MHz LVPECL No load

## Performance Specifications

Parameter	Min	Typ	Max	Units	Condition
<b>RF Output</b>					
Signal	ACMOS				
Load		15		pF	
Signal Level (Vol)			0.5 0.3	VDC VDC	Vs= 5.0V and 15pF load Vs= 3.3V and 15pF load
Signal Level (Voh)	4.5 3.0			VDC VDC	Vs= 5.0V and 15pF load Vs= 3.3V and 15pF load
Rise and fall times for ACMOS (measured 10% to 90%)			10 5 3	ns ns ns	1.0 to 23.9 MHz 24.0 to 79.7 MHz 80.0 to 125.0 MHz
Duty cycle	45 40		55 60	% %	@ 50% < 15 MHz @ 50% >= 15 MHz
Signal	PECL/LVPECL				
Load			50	ohm	Into Vs-2V or There in Equivalent
Signal Level (Vol)			Vs -1.62	VDC	
Signal Level (Voh)	Vs -1.025			VDC	
Rise and fall times (measured 20% to 80%)			1000 600	ps ps	<100 MHz >100 MHz
Start-up Time			10	ms	
Duty cycle (LVPECL)	45 40		55 60	% %	@ 50% Vdd @ 50% Vdd
Jitter (rms)			5 1	ps ps	BW = 10Hz to 20 MHz BW = 12 kHz to 20 MHz
Period Jitter (pk-pk)			40	ps	10,000 samples- Rising edge
<b>Frequency Tuning (EFC)</b>					
Absolute Pull Range		±30 ±50		ppm ppm	
Linearity		10	15	%	
Tuning Slope	Positive				
Control Voltage Range	0.5 0.3	2.5 1.65	4.5 3.0	VDC VDC	with Vs=5.0VDC with Vs=3.3VDC
<b>Additional Parameters</b>					
Phase Noise <sup>3</sup> (typical @ 77.76 MHz)			-80	dBc/Hz	10 Hz
			-110	dBc/Hz	100 Hz
			-130	dBc/Hz	1 KHz
			-150	dBc/Hz	10 KHz
			-160	dBc/Hz	100 KHz
Phase Noise <sup>3</sup> (typical @ 155.52 MHz)			-70	dBc/Hz	10 Hz
			-100	dBc/Hz	100 Hz
			-125	dBc/Hz	1 kHz
			-145	dBc/Hz	10 KHz
			-155	dBc/Hz	100 KHz
Screening	Vectron Verification or Class B Screening I/A/W MIL-PRF55310				

## Performance Specifications

Parameter	Min	Typ	Max	Units	Condition
Weight			<2.0	g	
Processing & Packing					Handling & processing note
Output Enable <sup>6</sup>	Logic "0" input = Outputs disabled (Tri-state) Logic "1" or floating input = Outputs enabled)				ACMOS Output
	Logic "0" or floating input = Outputs enabled) Logic "1" input = Outputs disabled (Tri-state)				PECL/LVPECL Output
<b>Absolute Maximum Ratings</b>					
Supply voltage (Vs)			7.0	V	with Vs=5.0 and 3.3 VDC
Operable temperature range	-55		+125	°C	
Storage temperature range	-55		+125	°C	

Environmental Compliance	
Mechanical Shock	MIL-STD-883, Method 2002.5, Condition C (3000 g)
Random Vibration	MIL-STD-883, Method 2026, Condition J (36.6 g)
Sine Vibration	MIL-STD-202, Method 204, Condition G (30 g)
Seal Test	MIL-STD-883 Method 1014 Condition A2 (Fine)
Seal Test	MIL-STD-202 Method 112 Condition D (Gross)
Temperature Cycling	MIL-STD-883 Method 1010 Condition B (1000 Cycles)
Acceleration	MIL-STD-883 Method 2001 Condition A (5000 g, Y1 Plane)
Thermal Shock	MIL-STD-883, Method 107, Condition B
Solderability	MIL-STD-202, Method 208
Leak Test (Fine and Gross)	MIL-STD-883, Method 1014, Condition A1 and C1

## Recommended Reflow Profiles for Pb-Free & Sn-Pb

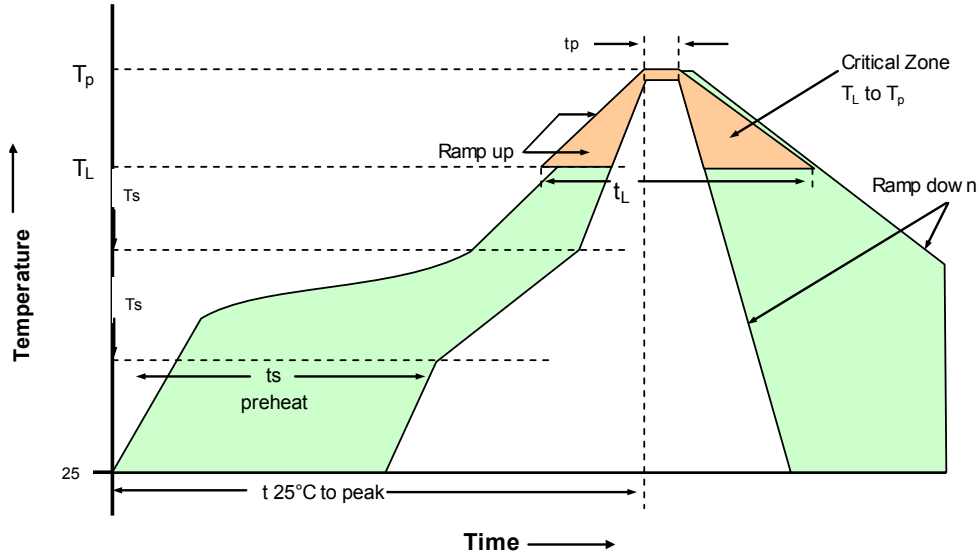

### 230°C Reflow Profile

Profile Feature	Sn-Pb Assembly	Profile Feature	Sn-Pb Assembly
Average ramp-up rate (TL to TP)	3°C/secod max.	Time 25°C to Peak Temperature	4 minutes max.
Preheat - Temperature min T <sub>sm</sub> - Temperature Min T <sub>smax</sub> - Time (min to max) (ts)	135°C 155°C 60-90 seconds	Time maintained above - Temperature (TL) - Time (tL)	183°C 45-60 seconds
T <sub>smax</sub> to TL -Ramp-up Rate	3°C/secod max.		
Time maintained above - Temperature (TL) - Time (TL)	183°C 40-60 seconds	Time within 5°C of actual Peak Temperature (tp)	10-20 seonds max.
Peak Temperature (Tp)	max 230°C	Ramp-down Rate	6°C/second max.

**Note:** All temperatures refer to topside of the package, measured on the package body surface.

### 260°C Reflow Profile

Profile Feature	Pb-Free Assembly	Profile Feature	Pb-Free Assembly
Average ramp-up rate (TL to TP)	3°C/secod max.	Time 25°C to Peak Temperature	8 minutes max.
Preheat - Temperature min T <sub>sm</sub> - Temperature min T <sub>smax</sub> - Time (min to max) (ts)	150°C 200°C 60-180 seconds	Time maintained above - Temperature (TL) - Time (tL)	217°C 60-150 seconds
T <sub>smax</sub> to TL -Ramp-up Rate	3°C/secod max.		
Time maintained above - Temperature (TL) - Time (TL)	217°C 60-150 seconds	Time within 5°C of actual Peak Temperature (tp)	20-40 seonds max.
Peak Temperature (Tp)	max 260°C	Ramp-down Rate	6°C/second max.

**Note:** All temperatures refer to topside of the package, measured on the package body surface.

# Outline Drawing / Enclosure

Dimensions: Inches (mm)

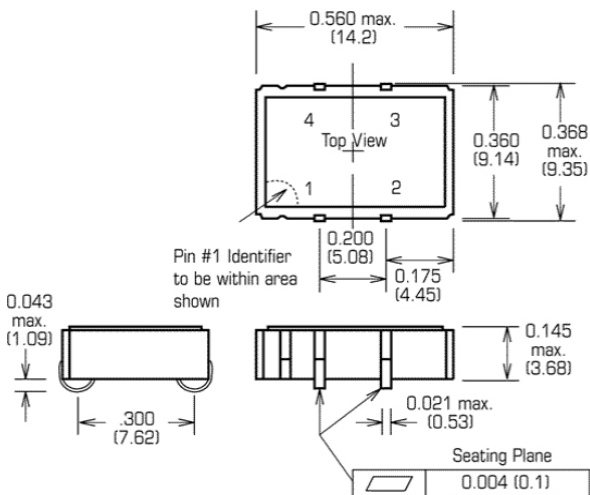

Type A (4-Leads) ACMOS/TTL		
Code	Height "H"	Pin Length
0	3.68	1.09

Pin Connections	
1	VCXO input
2	Ground (Case)
3	RF Output
4	Supply

Dimensions: Inches (mm)

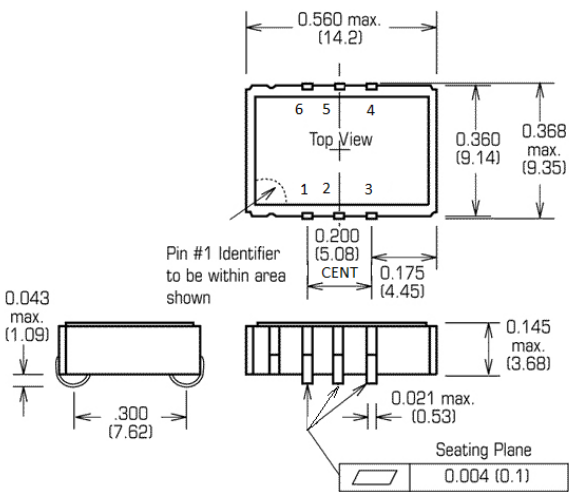

Type B (6-Leads) ACMOS/TTL		
Code	Height "H"	Stand-off
1	3.68	1.09

Pin Connections	
1	VCXO input
2	Enable/Disable or N/C
3	Ground (Case)
4	RF Output
5	N/C
6	Supply Voltage

Type B (6-Leads) PECL/LVPECL		
Code	Height "H"	Stand-off
1	3.68	1.09

Pin Connections	
1	VCXO input
2	Enable/Disable or N/C
3	Ground (Case)
4	RF Output
5	Complementary Output
6	Supply Voltage

## Ordering Information

**VX - 507 0 - D A T - K X X X - 10M000000**

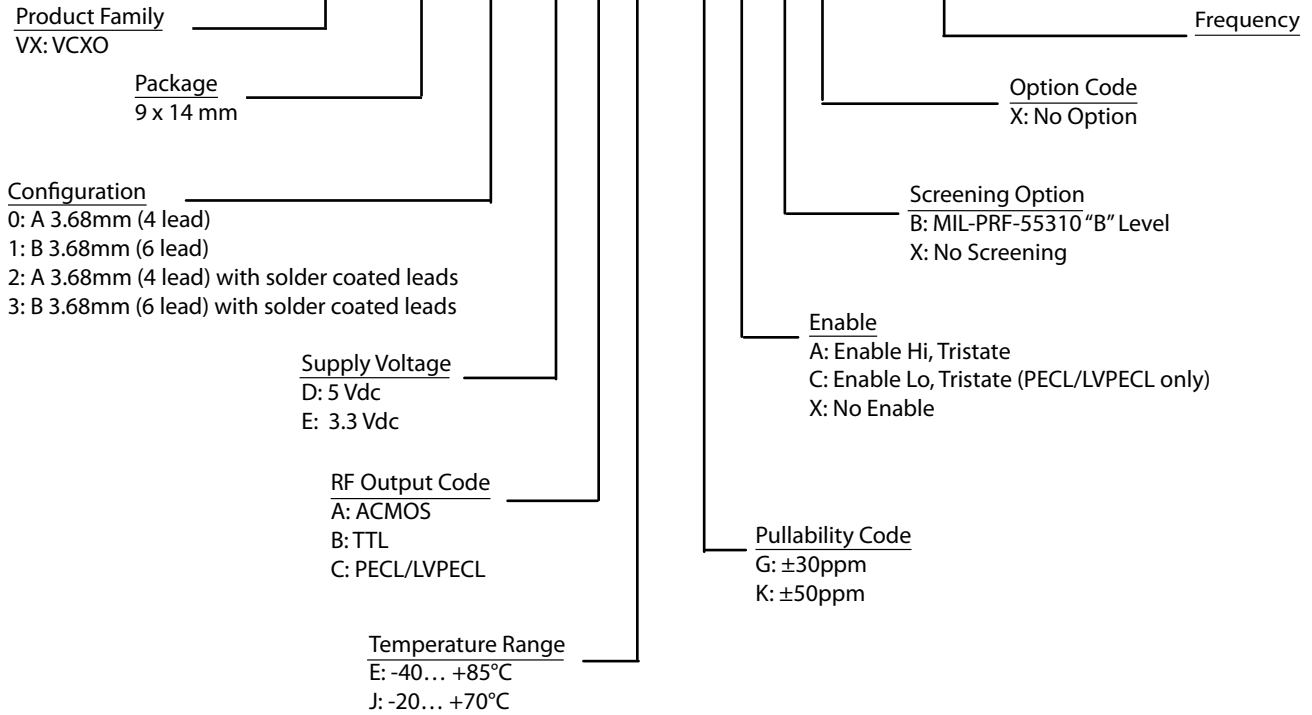

**Notes:**

1. Contact factory for improved stabilities or additional product options. Not all options and codes are available at all frequencies.
2. Unless other stated all values are valid after warm-up time and refer to typical conditions for supply voltage, frequency control voltage, load, temperature (25°C).
3. Phase noise degrades with increasing output frequency.
4. Subject to technical modification.
5. Contact factory for availability.
6. Output enable option only available for type B (6-Leads) device.

## Contact Information

**USA:**

100 Watts Street  
Mt Holly Springs, PA 17065  
Tel: 1.717.486.3411  
Fax: 1.717.486.5920

**Europe:**

Landstrasse  
74924 Neckarbischofsheim  
Germany  
Tel: +49 (0) 7268.801.0  
Fax: +49 (0) 7268.801.281



Information contained in this publication regarding device applications and the like is provided only for your convenience and may be superseded by updates. It is your responsibility to ensure that your application meets with your specifications. MICROCHIP MAKES NO REPRESENTATION OR WARRANTIES OF ANY KIND WHETHER EXPRESS OR IMPLIED, WRITTEN OR ORAL, STATUTORY OR OTHERWISE, RELATED TO THE INFORMATION INCLUDING, BUT NOT LIMITED TO ITS CONDITION, QUALITY, PERFORMANCE, MERCHANTABILITY OR FITNESS FOR PURPOSE. Microchip disclaims all liability arising from this information and its use. Use of Microchip devices in life support and/or safety applications is entirely at the buyer's risk, and the buyer agrees to defend, indemnify and hold harmless Microchip from any and all damages, claims, suits, or expenses resulting from such use. No licenses are conveyed, implicitly, or otherwise, under any Microchip intellectual property rights unless otherwise stated.

**Trademarks**

The Microchip and Vectron names, the Microchip and Microchip/Vectron logo, are registered trademarks of Microchip Technology Incorporated in the U.S.A. and other countries.