

AN7223

AM Tuner, FM/AM IF Amplifier Circuit for Radio Cassette Recorder

■ Overview

The AN7223 is an IC designed for high-class radio cassette recorder with multifunctioned FM/AM IF system.

■ Features

- Wide operating supply voltage range : $V_{CC} = 2.8V \sim 12V$
- Incorporating both FM and AM detectors
- Incorporating a level indicator output (FM/AM common use)
- AM : High sensitivity, including RF amplifier
- Low power consumption
- Muting control
- AFC control
- Fewer external parts
- High stability on both AM and FM
- Low shock noise level from function switch operation
- SW band available ($f = 30MHz$)

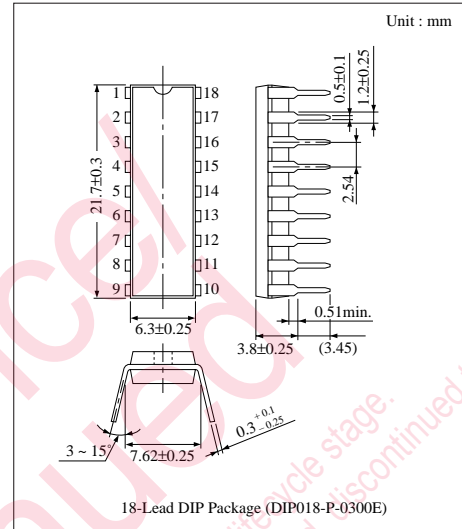

■ Block Diagram

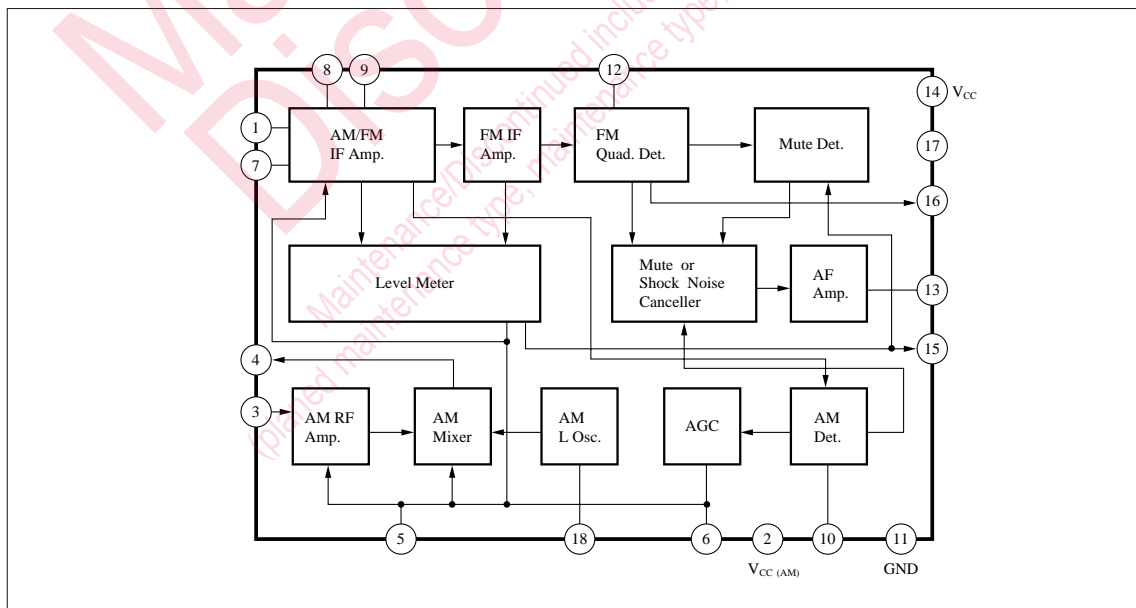

■ Pin Descriptions

Pin No.	Pin Name	Pin No.	Pin Name
1	FM IF Amp. Input	10	AM Detection Output
2	V _{CC} (AM)	11	GND
3	AM RF Amp. Input	12	FM Detector Coil
4	AM Mixer Output	13	AF Output
5	AGC Output (2)	14	V _{CC}
6	AGC Output (1)	15	Level Meter Output
7	AM IF Amp. Input	16	AFC Output
8	IF By-pass	17	Reference Voltage
9	IF By-pass	18	Local Oscillation

■ Absolute Maximum Ratings (Ta=25°C)

Parameter	Symbol	Rating	Unit
Supply Voltage	V _{CC}	14.4	V
Power Dissipation	P _D	317	mW
Operating Ambient Temperature	T _{opr}	-20 ~ + 75	°C
Storage Temperature	T _{stg}	-55 ~ + 150	°C

■ Electrical Characteristics (V_{CC}=5V, Ta= 25°C)

Parameter		Symbol	Condition	min.	typ.	max.	Unit
FM	Total Circuit Current	I _{tot}	(DC measurement)	9	14	20	mA
	Demodulation Output Level	v _{O (FM)}	V _i = 80dBμ, f=10.7MHz, f _{dev.} = 22.5kHz, f _m = 400Hz	75	100	125	mV
	Limiting Sensitivity	V _{i (lim)}	Input at v _O = -3dB	41.5	44.5	47.5	dBμ
	Muting Sensitivity	V _{i (mute)}	Input at v _O = less than -20dB	45	50	59	dBμ
	Signal Meter Driving Output 1	V ₁₅	V _i = 50dBμ, f=10.7MHz, f _{dev.} = 22.5kHz, f _m = 400Hz	120	600	1150	mV
Signal Meter Driving Output 2	V ₁₅	V _i = 80dBμ, f= 10.7MHz, f _{dev.} = 22.5kHz, f _m = 400Hz	1.14	1.26	1.42	V	
AM	Total Circuit Current	I _{tot}	(DC measurement)	8	13	19	mA
	Detection Output Level	v _{O (AM)}	V _i = 80dBμ, f= 1MHz, Mod.= 30%, f _m = 400Hz	60	80	100	mV
	Max.Sensitivity	S _{max.}	Input at v _O = 10mV	4.5	9.5	12.5	dBμ
	Signal Meter Driving Output 1	V ₁₅	V _i = -10dBμ, f= 1MHz, Mod.= 30%, f _m = 400Hz	0	—	130	mV
	Signal Meter Driving Output 2	V ₁₅	V _i = 80dBμ, f= 1MHz, Mod.= 30%, f _m = 400Hz	1.12	1.25	1.38	V

■ Application Circuit

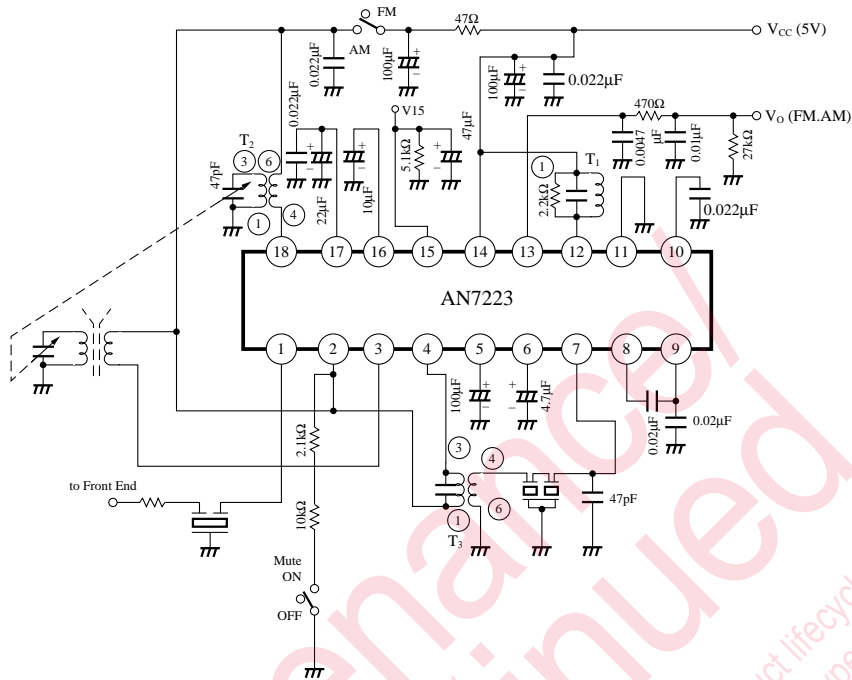

■ Coil Specifications

Symbol	Use, Freq	Type No.	Maker	Connection Diagram	Number of Turns	Tuning Cap.	Unloaded Q
T ₁	FM Quad. Coil 10.7MHz	EIF-7S752A	MATSUSHITA		1 - 2 8T 2 - 3 5T 4 - 6 3T	100pF	90±20%
T ₂	AM MW Osc. Coil	ELL-7S754	MATSUSHITA		1 - 2 4T 2 - 3 125T 4 - 6 7T	—	95±20%
T ₃	AM Mix. Output 455kHz	EIA-7S802A	MATSUSHITA		3 - 2 35T 6 - 4 10T 2 - 1 19T	1500pF	60±30%

■ Ceramic Filter Specification

Symbol	Use	Type No.	Maker	Center Freq.	Band Width	Loss
CF ₁	AM IF	CFM2-455B	TOKO	455kHz	7kHz (-6dB)	2.6dB

Request for your special attention and precautions in using the technical information and semiconductors described in this book

- (1) If any of the products or technical information described in this book is to be exported or provided to non-residents, the laws and regulations of the exporting country, especially, those with regard to security export control, must be observed.
- (2) The technical information described in this book is intended only to show the main characteristics and application circuit examples of the products, and no license is granted under any intellectual property right or other right owned by our company or any other company. Therefore, no responsibility is assumed by our company as to the infringement upon any such right owned by any other company which may arise as a result of the use of technical information described in this book.
- (3) The products described in this book are intended to be used for standard applications or general electronic equipment (such as office equipment, communications equipment, measuring instruments and household appliances).
Consult our sales staff in advance for information on the following applications:
 - Special applications (such as for airplanes, aerospace, automobiles, traffic control equipment, combustion equipment, life support systems and safety devices) in which exceptional quality and reliability are required, or if the failure or malfunction of the products may directly jeopardize life or harm the human body.
 - Any applications other than the standard applications intended.
- (4) The products and product specifications described in this book are subject to change without notice for modification and/or improvement. At the final stage of your design, purchasing, or use of the products, therefore, ask for the most up-to-date Product Standards in advance to make sure that the latest specifications satisfy your requirements.
- (5) When designing your equipment, comply with the range of absolute maximum rating and the guaranteed operating conditions (operating power supply voltage and operating environment etc.). Especially, please be careful not to exceed the range of absolute maximum rating on the transient state, such as power-on, power-off and mode-switching. Otherwise, we will not be liable for any defect which may arise later in your equipment.
 - Even when the products are used within the guaranteed values, take into the consideration of incidence of break down and failure mode, possible to occur to semiconductor products. Measures on the systems such as redundant design, arresting the spread of fire or preventing glitch are recommended in order to prevent physical injury, fire, social damages, for example, by using the products.
- (6) Comply with the instructions for use in order to prevent breakdown and characteristics change due to external factors (ESD, EOS, thermal stress and mechanical stress) at the time of handling, mounting or at customer's process. When using products for which damp-proof packing is required, satisfy the conditions, such as shelf life and the elapsed time since first opening the packages.
- (7) This book may be not reprinted or reproduced whether wholly or partially, without the prior written permission of Matsushita Electric Industrial Co., Ltd.