

DM93S62 9-Input Parity Checker/Generator

General Description

The DM93S62 is a very high speed 9-input parity checker/generator for use in error detection and error correction applications. The DM93S62 provides odd and even parity for up to nine data bits. The even parity output (PE) is HIGH if an

even number of inputs are HIGH and \bar{E} is LOW. The odd parity output (PO) will be HIGH if an odd number of inputs are HIGH and \bar{E} is LOW. A HIGH level on the Enable (\bar{E}) input forces both outputs LOW.

Connection Diagram

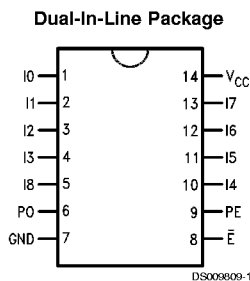

Order Number DM93S62N
Package Number N14A

Logic Symbol

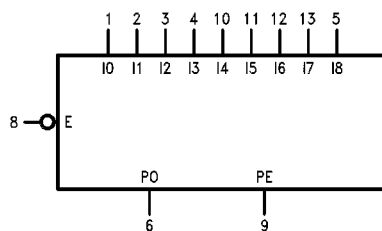

VCC = Pin 14
GND = Pin 7

Pin Name	Description
I0–I8	Data Inputs
\bar{E}	Output Enable (Active Low)
PO	Odd Parity Output
PE	Even Parity Output

Truth Table

(\bar{E} = LOW)

Number of Inputs I0–I8 that are HIGH	Outputs	
	PO	PE
1, 3, 5, 7, 9	H	L
0, 2, 4, 6, 8	L	H

H = HIGH Voltage Level
L = LOW Voltage Level

Absolute Maximum Ratings (Note 1)

Supply Voltage
Input Voltage

7V
5.5V

Operating Free Air Temperature Range

DM93S
Storage Temperature Range

0°C to +70°C
-65°C to +150°C

Recommended Operating Conditions

Symbol	Parameter	DM93S62			Units
		Min	Nom	Max	
V _{CC}	Supply Voltage	4.75	5	5.25	V
V _{IH}	High Level Input Voltage	2			V
V _{IL}	Low Level Input Voltage			0.8	V
I _{OH}	High Level Output Current			-1	mA
I _{OL}	Low Level Output Current			20	mA
T _A	Free Air Operating Temperature	0		70	°C

Note 1: The "Absolute Maximum Ratings" are those values beyond which the safety of the device cannot be guaranteed. The device should not be operated at these limits. The parametric values defined in the "Electrical Characteristics" table are not guaranteed at the absolute maximum ratings. The "Recommended Operating Conditions" table will define the conditions for actual device operation.

Electrical Characteristics

Over recommended operating free air temperature range (unless otherwise noted)

Symbol	Parameter	Conditions	Min	Typ (Note 2)	Max	Units
V _I	Input Clamp Voltage	V _{CC} = Min, I _I = -18 mA			-1.2	V
V _{OH}	High Level Output Voltage	V _{CC} = Min, I _{OH} = Max V _{IL} = Max	2.7	3.4		V
V _{OL}	Low Level Output Voltage	V _{CC} = Min, I _{OL} = Max V _{IH} = Min		0.35	0.5	V
I _I	Input Current @ Max Input Voltage	V _{CC} = Max, V _I = 5.5V			1	mA
I _{IH}	High Level Input Current	V _{CC} = Max, V _I = 2.7V			50	μA
I _{IL}	Low Level Input Current	V _{CC} = Max, V _I = 0.5V, I _O -I ₈			-1.6	mA
		V _{CC} = Max, V _I = 0.5V, \bar{E} Only			-3.2	
I _{OS}	Short Circuit Output Current	V _{CC} = Max (Note 3)	-40		-100	mA
I _{CC}	Supply Current	V _{CC} = Max			65	mA

Note 2: All typicals are at V_{CC} = 5V, T_A = 25°C.

Note 3: Not more than one output should be shorted at a time, and the duration should not exceed one second.

Switching Characteristics

$V_{CC} = +5.0V$, $T_A = +25^\circ C$ (See Section 1 for waveforms and load configurations)

Symbol	Parameter	$C_L = 15 \text{ pF}$		Units
		Min	Max	
t_{PLH}	Propagation Delay		26	ns
t_{PHL}	I0–I7 to PE		22	
t_{PLH}	Propagation Delay		12	ns
t_{PHL}	I8 to PE		9.0	
t_{PLH}	Propagation Delay		26	ns
t_{PHL}	I0–I7 to PO		26	
t_{PLH}	Propagation Delay		13	ns
t_{PHL}	I8 to PO		13	
t_{PLH}	Propagation Delay		7.0	ns
t_{PHL}	\bar{E} to PE		7.0	
t_{PLH}	Propagation Delay		7.0	ns
t_{PHL}	\bar{E} to PO		7.0	

Functional Description

The DM93S62 is a very high speed 9-input parity checker or generator. It is intended primarily for error detection in systems which transmit data in 8-bit bytes, but it can be expanded to any number of data inputs. Both even and odd parity outputs are available to allow maximum flexibility for both parity generation and parity checking. When the device is enabled ($\bar{E} = \text{LOW}$), the Even Parity output (PE) is HIGH when an even number of inputs is HIGH, and the Odd Parity output (PO) is HIGH when an odd number of inputs is HIGH. The active LOW Enable (\bar{E}) controls the state of both outputs; when the Enable (\bar{E}) is HIGH, both outputs will be LOW. The Enable may be used to strobe the outputs at very high speeds to synchronize or inhibit the parity data.

The DM93S62 has been designed with two sections using Exclusive-NOR comparison techniques. Eight data inputs I0–I7 represent one section which will generate a parity bit in 16 ns to 20 ns. The ninth input (I8) bypasses three levels of logic and switches the outputs in 6.0 ns to 9.0 ns. This feature may be used to compensate for delayed arrival of the parity bit, allowing faster system cycle times (*Figure 1*). The fast I8 input is also useful when more than nine bits are to be checked. The output of one DM93S62 drives the I8 input of a second DM93S62, providing a 17-bit parity check in 29 ns (typ).

When some inputs of the DM93S62 are not used, such as for words of less than nine bits or when using parallel expansion techniques, there is an optimum delay scheme for termination of the unused inputs (see *Table 1*). In essence, if one of the inputs of any Exclusive-NOR stays HIGH, the delay from the other input to the output is minimized.

Functional Description (Continued)

TABLE 1. Termination Recommendations for Less than Nine Bits

Number of Data Inputs	I0	I1	I2	I3	I4	I5	I6	I7	I8
3	D0	L	D1	L	D2	L	L	L	L
4	D0	L	D1	L	D2	L	D3	L	L
5	D0	L	D1	L	D2	L	D3	L	D4
6	D0	D1	D2	D3	D4	L	D5	L	L
7	D0	D1	D2	D3	D4	L	D5	L	D6
8	D0	D1	D2	D3	D4	D5	D6	D7	L

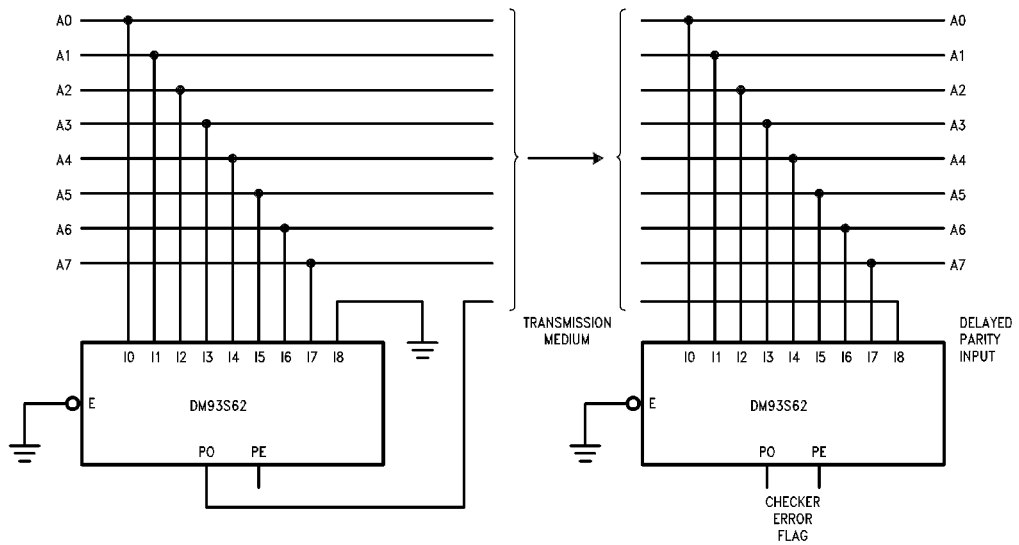

DS009809-3

FIGURE 1. Fast Input I8 allows Higher System Speed

Logic Diagram

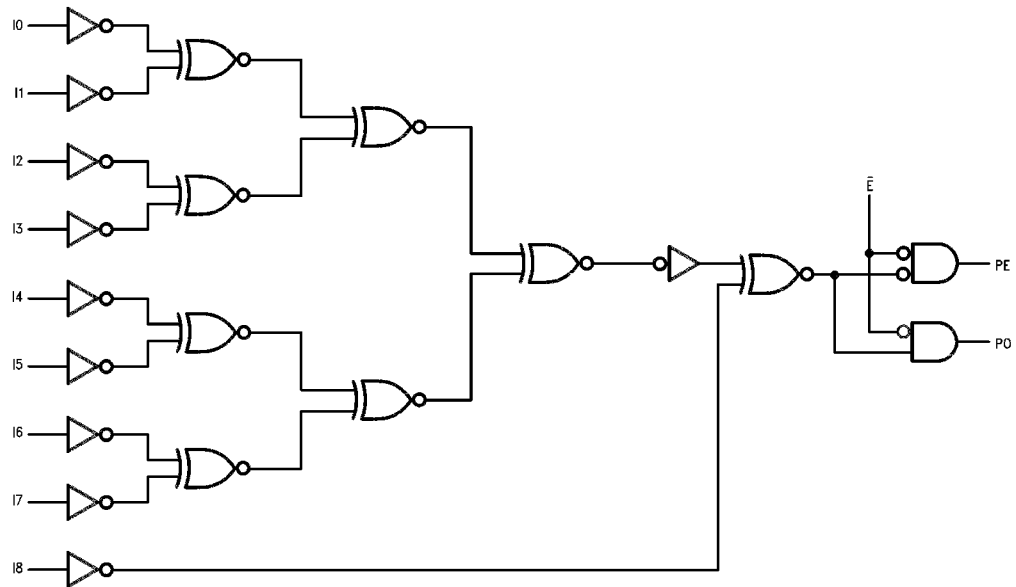

$$PO = (I_0 \oplus I_1 \oplus I_2 \oplus I_3 \oplus I_4 \oplus I_5 \oplus I_6 \oplus I_7 \oplus I_8) \cdot \bar{E}$$

$$PE = (I_0 \oplus I_1 \oplus I_2 \oplus I_3 \oplus I_4 \oplus I_5 \oplus I_6 \oplus I_7 \oplus I_8) \cdot \bar{E}$$

DS009809-4

Physical Dimensions inches (millimeters) unless otherwise noted

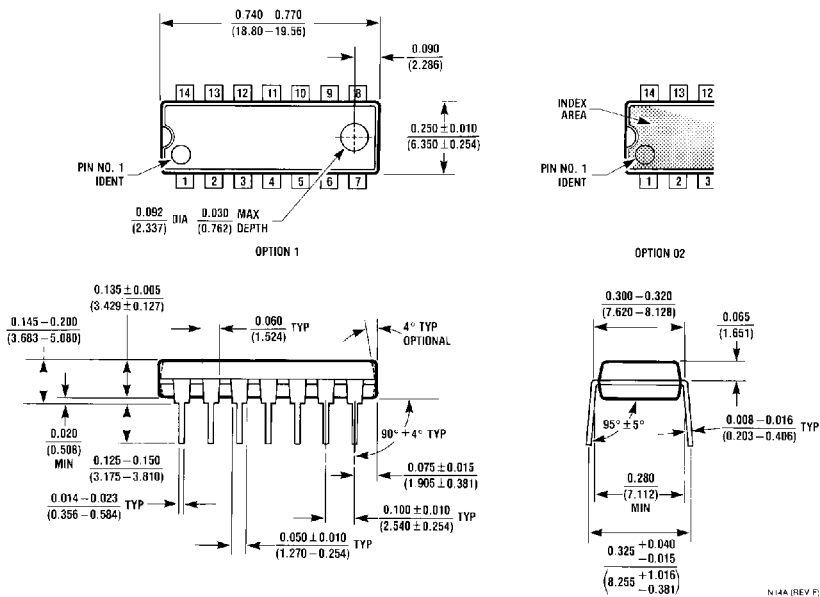

14-Lead Molded Dual-In-Line Package (N)
Order Number DM93S62N
Package Number N14A

LIFE SUPPORT POLICY

FAIRCHILD'S PRODUCTS ARE NOT AUTHORIZED FOR USE AS CRITICAL COMPONENTS IN LIFE SUPPORT DEVICES OR SYSTEMS WITHOUT THE EXPRESS WRITTEN APPROVAL OF THE PRESIDENT OF FAIRCHILD SEMICONDUCTOR CORPORATION. As used herein:

1. Life support devices or systems are devices or systems which, (a) are intended for surgical implant into the body, or (b) support or sustain life, and (c) whose failure to perform when properly used in accordance with instructions for use provided in the labeling, can be reasonably expected to result in a significant injury to the user.
2. A critical component in any component of a life support device or system whose failure to perform can be reasonably expected to cause the failure of the life support device or system, or to affect its safety or effectiveness.

Fairchild Semiconductor Corporation
 Americas
 Customer Response Center
 Tel: 1-888-522-5372

Fairchild Semiconductor Europe
 Fax: +49 (0) 1 80-530 85 86
 Email: europe.support@nsc.com
 Deutsch Tel: +49 (0) 8 141-35-0
 English Tel: +44 (0) 1 793-85-68-56
 Italy Tel: +39 (0) 2 57 5631

Fairchild Semiconductor Hong Kong Ltd.
 13th Floor, Straight Block,
 Ocean Centre, 5 Canton Rd.
 Tsimshatsui, Kowloon
 Hong Kong
 Tel: +852 2737-7200
 Fax: +852 2314-0061

National Semiconductor Japan Ltd.
 Tel: 81-3-5620-6175
 Fax: 81-3-5620-6179

www.fairchildsemi.com