

DP 7114

DIGITAL POTENTIOMETERS

SUMMARY

The DP7114 is a programmable digital potentiometer designed to replace mechanical potentiometers and variable resistors. Automated adjustment by product automation line is ideal. The DP7114 makes this possible and is suitable for applications where it is difficult to operate when machines require constant adjustment or in case of danger or at remote locations.

The DP7114 has a 32-tap resistance array between two terminals, RH and RL. The up/down counter and decoder controlled by 3 input terminals determines the tap connected to wiper resistance RW. Wiper settings stored in nonvolatile memory can not be lost even at power shutoff and will be automatically restored when power returns. Not affected by stored settings, the wiper can test new setting of the system.

The wiper control of the DP7114 is made by three input terminals, \overline{CS} , U/\overline{D} and \overline{INC} . The \overline{INC} input increments wiper to direction determined in U/\overline{D} input logic condition. The \overline{CS} input terminal is for device-select use and used when wiper position is stored before power shutoff. The digital potentiometer can be used as a voltage partial pressure device or 2-terminal variable resistor. The DP7114 offers valuable capabilities and programmability to a wide variety of applications such as parameter adjustment and signal processing.

CONFIGURATION

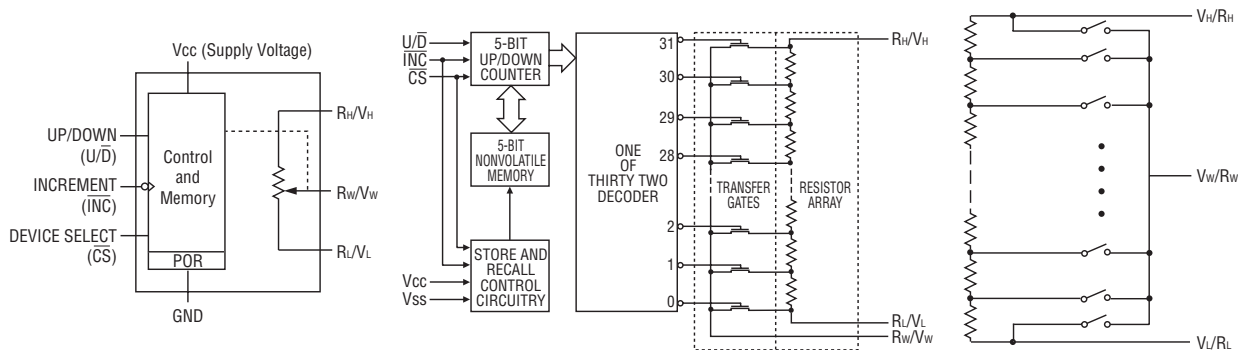

Circuit block diagram

Electricity-equivalent circuit of POT section

CONTACT LAYOUT

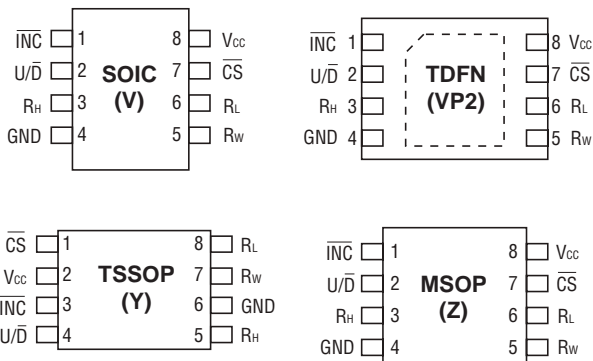

DP 7114

DIGITAL POTENTIOMETERS

■ TERMINAL FUNCTIONS

Terminal name	Functions
\overline{INC}	Increment control input
U/\overline{D}	Up/Down control input
R_H	High-end potentiometer terminal
GND	Ground
R_W	Wiper terminal
R_L	Low-end potentiometer terminal
\overline{CS}	Chip select
V_{CC}	Power voltage

■ FUNCTIONS OF EACH TERMINAL

\overline{INC} : Increment control input

This \overline{INC} input moves wiper to the up and down direction selected by conditions of U/\overline{D} input at the VIL edge.

U/\overline{D} : Up/down control input

U/\overline{D} input controls moving direction of wiper. When U/\overline{D} is in H state and \overline{CS} is in L state, this input moves the wiper to R_H from transition state of H - L of the INC. When U/\overline{D} and \overline{CS} are in L state, it moves the wiper to R_L direction in the transition of H to L of the INC.

R_H : High-end potentiometer terminal

R_H is a high-end potentiometer terminal. This terminal does not require higher voltage than R_L terminal. But, R_H voltage should not be over V_{CC} nor under GND.

R_W : Wiper terminal

R_W is a wiper terminal of potentiometer. The position within resistance arrays are controlled by control input terminals of INC, U/\overline{D} and \overline{CS} .

R_L : Low-end potentiometer terminal

R_L is a low-end potentiometer terminal. This terminal does not need to connect lower voltage than R_H terminal. But, R_L voltage should not be over V_{CC} nor under GND. R_H and R_L can be changed electrically.

\overline{CS} : Chip select

Chip select input is used to make a DP7114 control input effective and becomes effective in the L state. When \overline{CS} is in the H state, inputs of \overline{INC} and U/\overline{D} does not give effect or change to wiper position.

■ OPERATION EXPLANATION

The R_H and R_L terminals of the DP7114 are equivalent to high and low terminals of mechanical potentiometers. The DP7114 is a digital potentiometer of which R_W terminal operates as a wiper. The model has 32 taps including terminators of R_H and R_L . There are 31 resistance arrays linearly connected between terminal R_H and R_L . This wiper terminal is connected to one of 32 taps and controlled by 3 inputs of \overline{INC} , U/\overline{D} and \overline{CS} . This input controls the 5-bit up/down counter which can decode to select wiper position. Selected wiper position data is stored into nonvolatile memories by \overline{INC} and \overline{CS} inputs.

When \overline{CS} is in the L state, DP7114 is selected and responds to U/\overline{D} and \overline{INC} inputs. In transition from H of \overline{INC} to L, wiper will be incremented or decremented. The wiper acts like mechanical and does not move from the last position. Counter values will be saved in nonvolatile memories by transition from H of the \overline{INC} input to H of the \overline{CS} . When DP7114 power is shut down, counter position saved in the last will be kept in nonvolatile memories. When DP7114 power returns, contents within memories will be renewed and counter values are set on the counter. When \overline{INC} is in L state, DP7114 will not be selected and shut down without saving the current wiper position in nonvolatile memories, thereby the system will recall preset values always stored in nonvolatile memories.

■ OPERATION MODE

\overline{INC}	\overline{CS}	U/\overline{D}	Operation
High to Low	Low	High	Wiper toward H
High to Low	Low	Low	Wiper toward L
High	Low to High	X	Store Wiper Position
Low	Low to High	X	No Store, Return to Standby
X	High	X	Standby

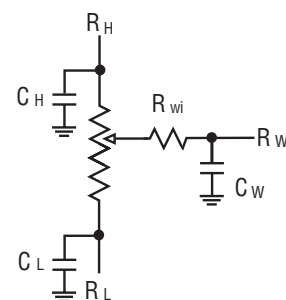

Equivalent circuit of potentiometer

DP 7114

DIGITAL POTENTIOMETERS

ABSOLUTE MAXIMUM RATINGS

Supply voltage
 V_{CC} to GND - 0.5 V ~ + 7 V

Inputs
 CS to GND - 0.5 V ~ V_{CC} + 0.5 V
 INC to GND - 0.5 V ~ V_{CC} + 0.5 V
 U/D to GND - 0.5 V ~ V_{CC} + 0.5 V
 R_H to GND - 0.5 V ~ V_{CC} + 0.5 V
 R_L to GND - 0.5 V ~ V_{CC} + 0.5 V
 R_w to GND - 0.5 V ~ V_{CC} + 0.5 V

Operating ambient temperature
 Industrial ('I' suffix) - 40 °C ~ + 85 °C
 Junction Temperature + 150 °C
 Storage Temperature - 65 °C ~ + 150 °C
 Lead Soldering (10 sec max) + 300 °C

* Stresses above those listed under Absolute Maximum Ratings may cause permanent damage to the device. Absolute Maximum Ratings are limited values applied individually while other parameters are within specified operating conditions, and functional operation at any of these conditions is NOT implied. Device performance and reliability may be impaired by exposure to absolute rating conditions for extended periods of time.

RELIABILITY CHARACTERISTICS

Symbol	Parameter	Conditions	Min	Typ	Max	Units
V _{ZAP} ⁽¹⁾	ESD Susceptibility	MIL-STD-883, Test Method 3015	2000	—	—	Volts
I _{LTH} ⁽¹⁾⁽²⁾	Latch-Up	JEDEC Standard 17	100	—	—	mA
T _{DR}	Data Retention	MIL-STD-883, Test Method 1008	100	—	—	Years
N _{END}	Endurance	MIL-STD-883, Test Method 1003	1,000,000	—	—	Stores

DC ELECTRICAL CHARACTERISTICS

Unless otherwise specified, the specs are defined at
 V_{CC} = +2.5 V to +6.0 V.

Power supply

Symbol	Parameter	Conditions	Min	Typ	Max	Units
V _{CC}	Operating Voltage Range	—	2.5	—	6.0	V
I _{CC1}	Supply Current (Increment)	V _{CC} = 6 V, f = 1 MHz, I _w = 0 V _{CC} = 6 V, f = 250 kHz, I _w = 0	—	—	100 50	μA
I _{CC2}	Supply Current (Write)	Programming, V _{CC} = 6 V V _{CC} = 3 V	—	—	1 500	mA μA
I _{SB1} ⁽²⁾	Supply Current (Standby)	CS = V _{CC} - 0.3 V U/D, INC = V _{CC} - 0.3 V or GND	—	—	1	μA

Logic inputs

Symbol	Parameter	Conditions	Min	Typ	Max	Units
I _{IH}	Input Leakage Current	V _{IN} = V _{CC}	—	—	10	μA
I _{IL}	Input Leakage Current	V _{IN} = 0 V	—	—	-10	μA
V _{IH2}	CMOS High Level input Voltage	2.5 V ≤ V _{CC} ≤ 6 V	V _{CC} × 0.7	—	V _{CC} + 0.3	V
V _{IL2}	CMOS Low Level input Voltage		-0.3	—	V _{CC} × 0.2	V

Notes : (1) This parameter is tested initially and after a design or process change that affects the parameter.
 (2) Latch-up protection is provided for stresses up to 100 mA on address and data pins from -1 V to V_{CC} + 1 V.
 (3) I_w = source or sink current.
 (4) The value is for reference.

DP 7114

DIGITAL POTENTIOMETERS

POTENTIOMETER PARAMETERS

Symbol	Parameter	Conditions	Min	Typ(1)	Max	Units
R _{POT}	Potentiometer Resistance	-10 Device	—	10	—	kΩ
		-50 Device	—	50	—	
		-00 Device	—	100	—	
R _{TOL}	Pot Resistance Tolerance	—	—	—	±20	%
V _{RH}	Voltage on R _H pin	—	0	—	V _{CC}	V
V _{RL}	Voltage on R _L pin	—	0	—	V _{CC}	V
RES	Resolution	—	—	3.2	—	%
INL	Integral Linearity Error	I _w ≤ 2 μA	—	0.5	1	LSB
DNL	Differential Linearity Error	I _w ≤ 2 μA	—	0.25	0.5	LSB
R _{WI}	Wiper Resistance	V _{CC} = 5 V, I _w = 1 mA	—	70	200	Ω
		V _{CC} = 2.5 V, I _w = 1 mA	—	150	400	Ω
I _{WI}	Wiper Current	—	-4.4	—	4.4	mA
TC _{POT}	TC of Pot Resistance	—	—	300	—	ppm/°C
TC _{RATIO}	Ratiometric TC	—	—	—	20	ppm/°C
V _N	Noise	100 kHz / 1 kHz	—	8/24	—	nV/√Hz
C _H /C _L /C _W	Potentiometer Capacitances	—	—	8/8/25	—	pF
f _c	Frequency Response	Passive Attenuator, 10 kΩ	—	1.7	—	MHz

AC TEST CONDITIONS

V _{CC} Range	2.5 V ≤ V _{CC} ≤ 6V
Input Pulse Levels	0.2 V _{CC} to 0.7 V _{CC}
Input Rise and Fall Times	10 ns
Input Reference Levels	0.5 V _{CC}

AC TIMING DIAGRAM

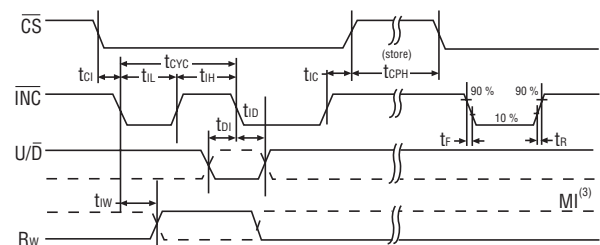

AC ELECTRICAL CHARACTERISTICS

V_{CC} = +2.5 V to +6.0 V, V_H = V_{CC}, V_L = 0 V

Symbol	Parameter	Min	Typ	Max	Units
t _{CI}	CS to INC Setup	100	—	—	ns
t _{DI}	U/D to INC Setup	50	—	—	ns
t _{ID}	U/D to INC Hold	100	—	—	ns
t _{IL}	INC LOW Period	250	—	—	ns
t _{IH}	INC HIGH Period	250	—	—	ns
t _{IC}	INC Inactive to CS Inactive	1	—	—	μs
t _{CPH}	CS Deselect Time (NO STORE)	100	—	—	ns
t _{CPH}	CS Deselect Time (STORE)	10	—	—	ms
t _{IW}	INC to V _{OUT} Change	—	1	5	μs
t _{CYC}	INC Cycle Time	1	—	—	μs
t _R , t _F ⁽²⁾	INC Input Rise and Fall Time	—	—	500	μs
t _{PU} ⁽²⁾	Power-up to Wiper Stable	—	—	1	ms
t _{WR}	Store Cycle	—	5	10	ms

- (1) The value is measured at temperature 25 °C and at the above defined power supply voltage.
- (2) The value is for reference.
- (3) MI shows minimum change unit of wiper output by changing wiper position.

DP series

DIGITAL POTENTIOMETERS

PART NUMBER DESIGNATION

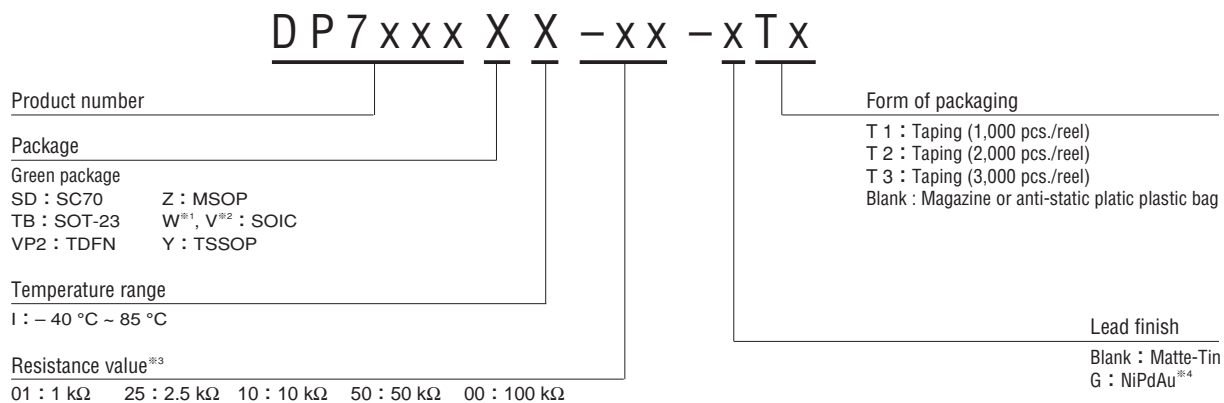

※1 : The relevant products are as follows.
 DP7221/DP7241/DP7251/DP7259/DP7261/DP7269/DP7401/DP7409/
 DP7411/DP7419
 ※2 : The relevant products are as follows.
 DP7111/DP7112/DP7113/DP7114/DP7115/DP7116

※3 : Resistance value is not marked on DP7116
 ※4 : The relevant products are as follows.
 DP7110 / DP7111 / DP7112 / DP7113 /
 DP7114 / DP7115 / DP7116 / DP7118 / DP7119 /
 DP7120 / DP7121 / DP7122 / DP7132 /
 DP7140 / DP7172
 Except MSOP package of DP7113, DP7116

Taping code and quantity

Package	Pin no.	Taping quantity (pcs./reel)			Magazine quantity (Maximum Q'ty/stick)
		1,000	2,000	3,000	
SC70	5/6			○	—
SOT-23	5/6/8			○	—
TDFN	8			○	—
MSOP	8			○	96 pcs.
MSOP	10			○	96 pcs.
SOIC	8			○	100 pcs.
SOIC	20	○			36 pcs.
SOIC	24	○			31 pcs.
TSSOP	8			○	100 pcs.
TSSOP	20		○		74 pcs.
TSSOP	24		○		62 pcs.

DP series DIGITAL POTENTIOMETERS

MARKING

Marking condition of IC top view is as follows;

MSOP

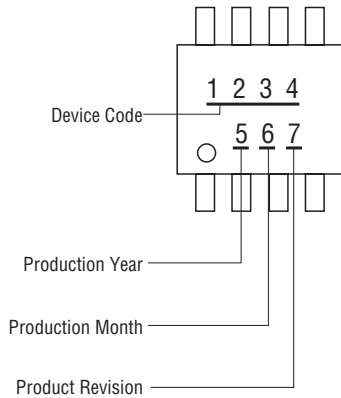

TSSOP

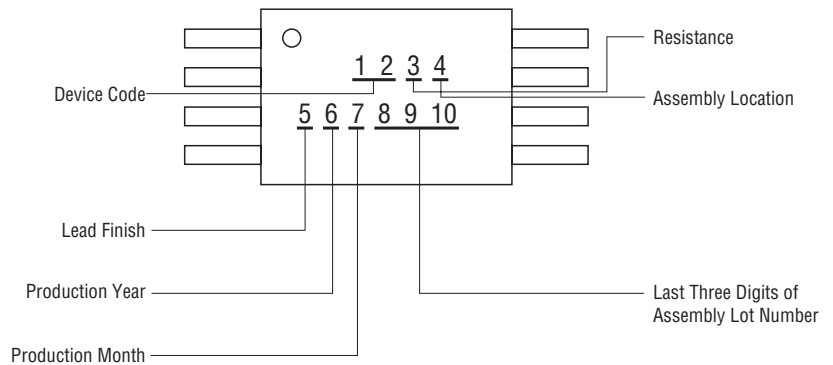

SOIC

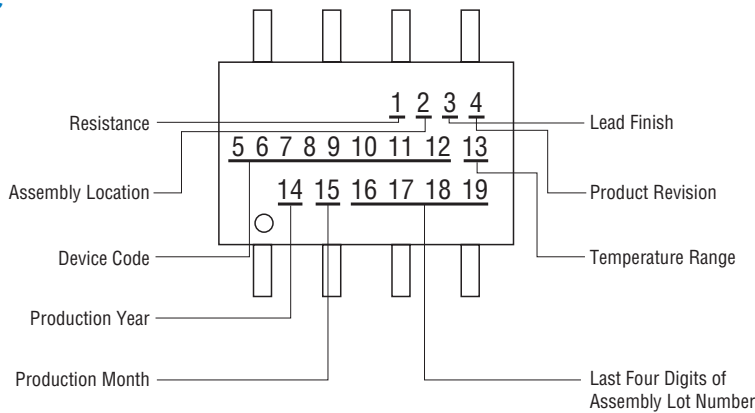

※Regarding the details of each part number, please refer to respective specifications.

TAPING PACKAGING SPECIFICATIONS

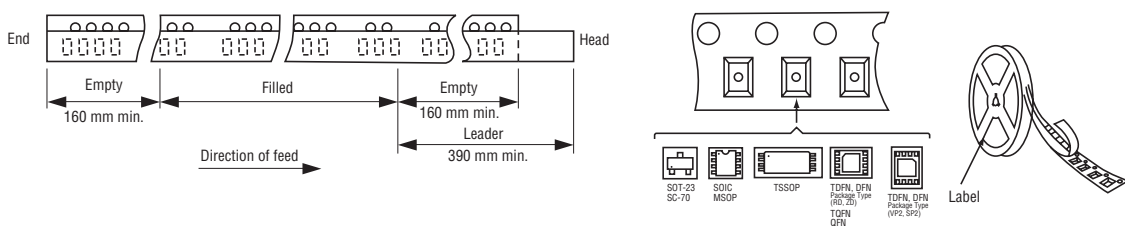

DP series DIGITAL POTENTIOMETERS

DEVELOPMENT SUPPORT KIT FOR DP

DP control can be carried out using a special interface board. With this, your product development time can be shortened.

- OS : Windows98/2000/XP
- I/O : USB interface
- Software : Copal DP
- ※ : Please order from one of our sales offices

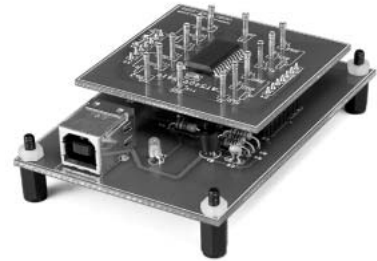

OUTLINE DIMENSIONS

Unit : mm

SC70/SOT-23/MSOP/
SOIC/TSSOP

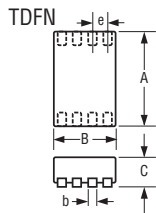
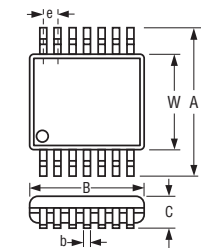

SC70/SOT-23/MSOP/SOIC/TSSOP/TDFN

Package	Pin no.	A(max/min)	B(max/min)	W(max/min)	C(max/min)	b(max/min)	e
SC70	5/6	2.40/1.80	2.20/1.80	1.35/1.15	1.10/0.80	0.30/0.15	0.65
SOT-23	5/6	2.80(Typ)	2.90(Typ)	1.60(Typ)	1.45/0.90	0.50/0.30	0.95
SOT-23	8	2.80(Typ)	2.90(Typ)	1.60(Typ)	1.45/0.90	0.38/0.28	0.65
TDFN	8	3.10/2.90	2.10/1.90	—	0.80/0.70	0.30/0.20	0.50
MSOP	8	5.00/4.80	3.10/2.90	3.10/2.90	0.95/0.75	0.38/0.22	0.65
MSOP	10	5.05/4.75	3.10/2.90	3.10/2.90	1.1max	0.27/0.17	0.50
SOIC	8	6.20/5.80	5.0/4.80	4.00/3.80	1.75/1.35	0.51/0.33	1.27
SOIC	20	10.64/10.01	13.00/12.60	7.60/7.40	2.64/2.36	0.51/0.31	1.27
SOIC	24	10.51/10.11	15.40/15.20	7.60/7.34	2.65/2.35	0.51/0.31	1.27
TSSOP	8	6.50/6.30	3.10/2.90	4.50/4.30	1.2max	0.30/0.19	0.65
TSSOP	20	6.50/6.30	6.60/6.40	4.50/4.30	1.2max	0.30/0.19	0.65
TSSOP	24	6.55/6.25	7.90/7.70	4.50/4.30	1.2max	0.30/0.19	0.65

RECOMMENDED P. C. B. PAD OUTLINE DIMENSIONS

Unit: mm

8 pins TDFN

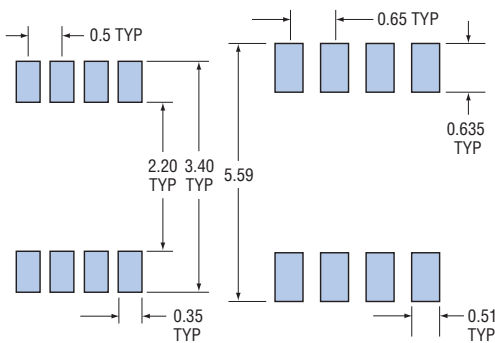

8 pins MSOP

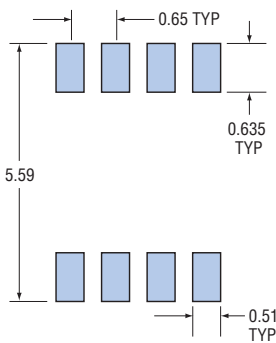

8 pins SOIC

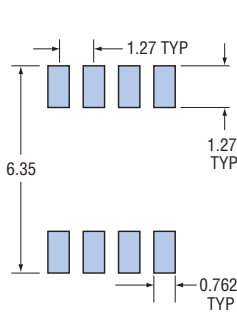

8 pins TSSOP

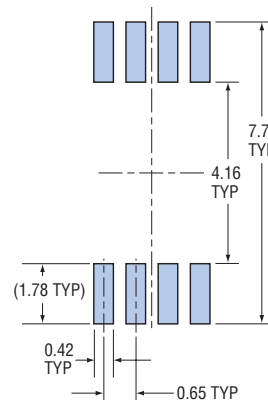

6 pins SC70

