

# ATS535JSB AND ATS535SSB

## PROGRAMMABLE, TRUE POWER-ON, HALL-EFFECT PROXIMITY SENSORS

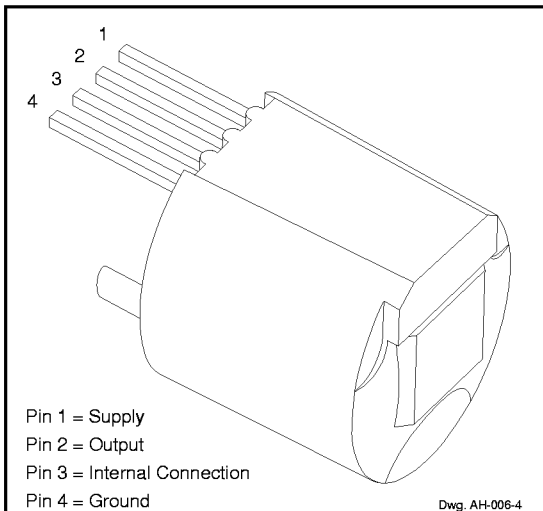

PRELIMINARY INFORMATION  
(subject to change without notice)  
April 12, 1999

### ABSOLUTE MAXIMUM RATINGS at $T_A = 25^\circ\text{C}$

Supply Voltage, $V_{CC}$ .....	26.5 V*
Reverse Supply Voltage, $V_{RCC}$ .....	-30 V
Oversupply Current, $I_{CC}$ .....	100 mA
Output Current, $I_{OUT}$ .....	Internally Limited
Output OFF Voltage, $V_{OUT}$ .....	26.5 V
Reverse Output Current, $I_{ROUT}$ .....	-50 mA
Package Power Dissipation, $P_D$ .....	See Graph
Operating Temperature Range, $T_A$ ATS535JSB .....	-40°C to +115°C
ATS535SSB .....	-20°C to +85°C
Storage Temperature, $T_S$ .....	+170°C

\* Operation at increased supply voltages with external circuitry is described in Applications Information.

The ATS535JSB and ATS535SSB programmable, true power-on (TPOS), proximity sensors are optimized Hall-effect IC/magnet combinations that provide power-on tooth/valley recognition in large gear-tooth sensing applications and proximity detection in other applications. Each sensor subassembly consists of a high-temperature plastic shell that holds together a samarium-cobalt magnet, a pole piece, and a single element, chopper-stabilized Hall-effect IC that can be programmed to match the magnetic circuit, optimizing sensor airgap and timing accuracy performance after final packaging. The small package can be easily assembled and used in conjunction with a wide variety of gear/target shapes and sizes. The two devices differ only in operating temperature range.

The sensing technology used for this sensor subassembly is Hall-effect based. The sensor incorporates a single-element Hall IC that switches in response to magnetic signals created by a ferrous target. The circuit eliminates magnet and system offsets such as those caused by tilt yet provides zero-speed detection capabilities without the associated running jitter inherent in classical digital solutions.

A proprietary dynamic offset cancelation technique, with an internal high-frequency clock, reduces the residual offset voltage, which is normally caused by device overmolding, temperature dependancies, and thermal stress. This technique produces devices that have an extremely stable quiescent output voltage, are immune to mechanical stress, and have precise recoverability after temperature cycling. Many problems normally associated with low-level analog signals are minimized by having the Hall element and amplifier in a single chip. Output precision is obtained by internal gain adjustments during the manufacturing process and operate-point programming in the user's application.

This sensor system is ideal for use in gathering speed, position, and timing information using gear-tooth-based configurations. The ATS535JSB/SSB are particularly suited to those applications that require accurate duty cycle control or accurate edge detection. The lower vibration sensitivity also makes these devices extremely useful for transmission speed sensing.

Continued next page

Always order by complete part number, e.g., **ATS535JSB**.

# ATS535JSB AND ATS535SSB PROGRAMMABLE, TRUE POWER-ON, HALL-EFFECT PROXIMITY SENSORS

## FUNCTIONAL BLOCK DIAGRAM

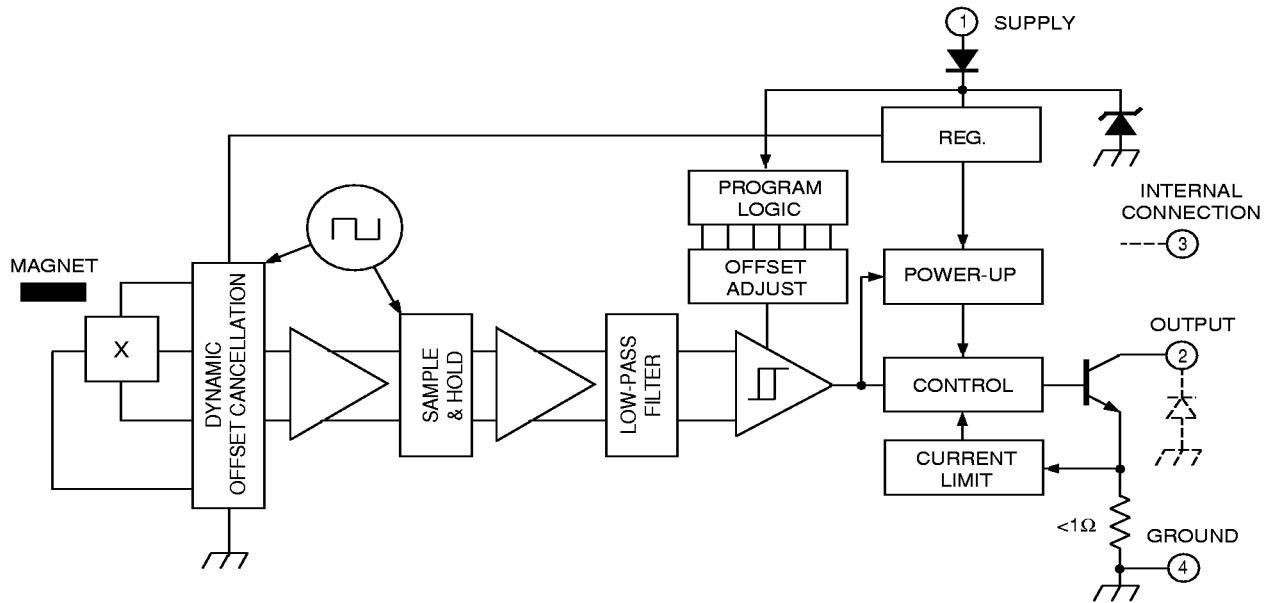

Dwg. FH-020-2

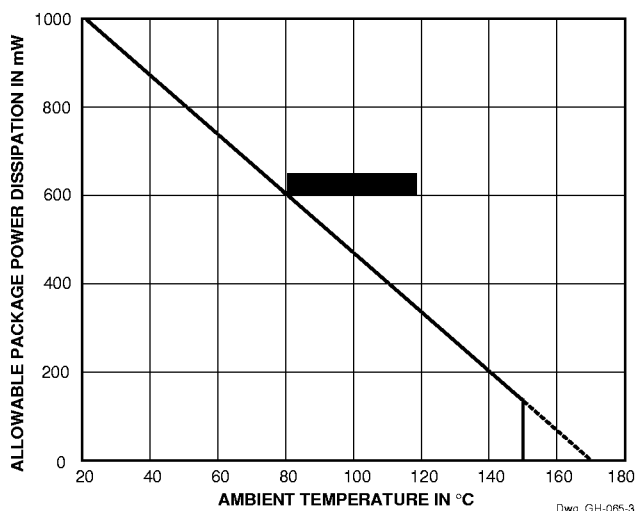

Dwg. GH-085-3

## FEATURES AND BENEFITS

- Chopper Stabilized for Extremely Low Switch-Point Drift and Immunity to Mechanical Stress
- Externally Programmed Switch Point
- On-Chip Supply-Transient Protection
- Output Short-Circuit Protection
- True Zero-Speed Operation
- High Vibration Immunity
- Single-Chip Sensing IC for High Reliability
- Small Mechanical Size
- Optimized Magnetic Circuit
- <math><50\ \mu\text{s}</math> Power-On Time
- Wide Operating Voltage Range
- Defined Power-On State



115 Northeast Cutoff, Box 15036  
Worcester, Massachusetts 01615-0036 (508) 853-5000  
Copyright © 1999, Allegro MicroSystems, Inc.

**ATS535JSB AND ATS535SSB**  
**PROGRAMMABLE, TRUE**  
**POWER-ON, HALL-EFFECT**  
**PROXIMITY SENSORS**

**ELECTRICAL CHARACTERISTICS** over operating voltage and temperature range (unless otherwise noted).

Characteristic	Symbol	Test Conditions	Limits			
			Min.	Typ.	Max.	Units
Supply Voltage	$V_{CC}$	Operating, $T_J < 165^\circ\text{C}$	4.25	–	26	V
Power-On State	POS	After programming, $V_{CC} = 0 \rightarrow 5\text{ V}$	HIGH	HIGH	HIGH	–
Low Output Voltage	$V_{OUT(SAT)}$	$I_{OUT} = 20\text{ mA}$	–	175	400	mV
Output Current Limit	$I_{OUTM}$	$V_{OUT} = 12\text{ V}$	65	80	95	mA
Output Leakage Current	$I_{OFF}$	$V_{OUT} = 24\text{ V}$	–	0.2	10	$\mu\text{A}$
Supply Current	$I_{CC}$	Before programming, output OFF	–	4.0	7.0	mA
		Before programming, output ON	–	5.0	8.0	mA
Reverse Supply Current	$I_{RCC}$	$V_{RCC} = -30\text{ V}$	–	–	-5.0	mA
Power-On Delay	$t_{on}$	$V_{CC} > 5\text{ V}$	–	20	50	$\mu\text{s}$
Output Rise Time	$t_r$	$R_L = 820\ \Omega$ , $C_L = 20\text{ pF}$	–	200	–	ns
Output Fall Time	$t_f$	$R_L = 820\ \Omega$ , $C_L = 20\text{ pF}$	–	100	–	ns
Clock Frequency	$f_C$		–	340	–	kHz
Zener Voltage	$V_Z$	$I_{ZT} = 100\ \mu\text{A}$ , $T_A = 25^\circ\text{C}$	27	32	–	V
Zener Impedance	$Z_Z$	$I_{ZT} = 10\text{ mA}$ , $T_A = 25^\circ\text{C}$	–	50	100	$\Omega$

NOTE: Typical data is at  $V_{CC} = 5\text{ V}$  and  $T_A = +25^\circ\text{C}$  and is for design information only.

**ATS535JSB AND ATS535SSB**  
**PROGRAMMABLE, TRUE**  
**POWER-ON, HALL-EFFECT**  
**PROXIMITY SENSORS**

**TYPICAL ELECTRICAL CHARACTERISTICS**

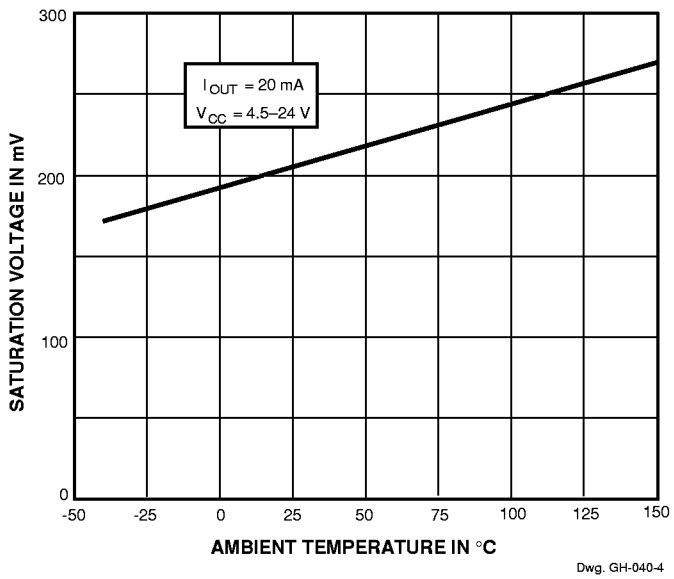
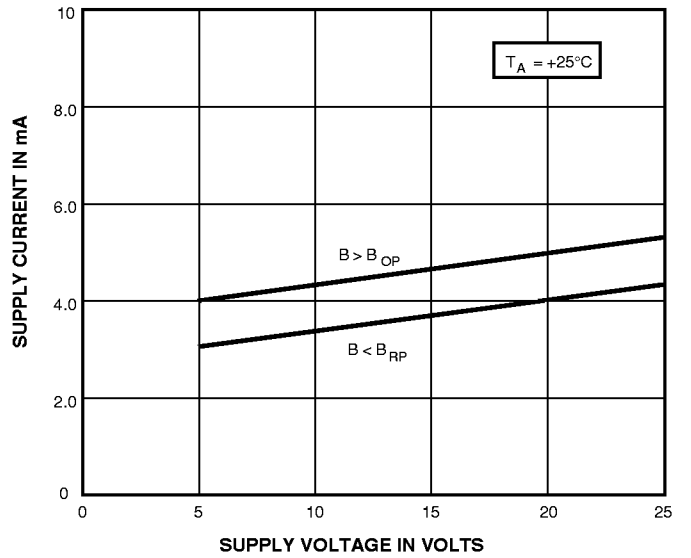
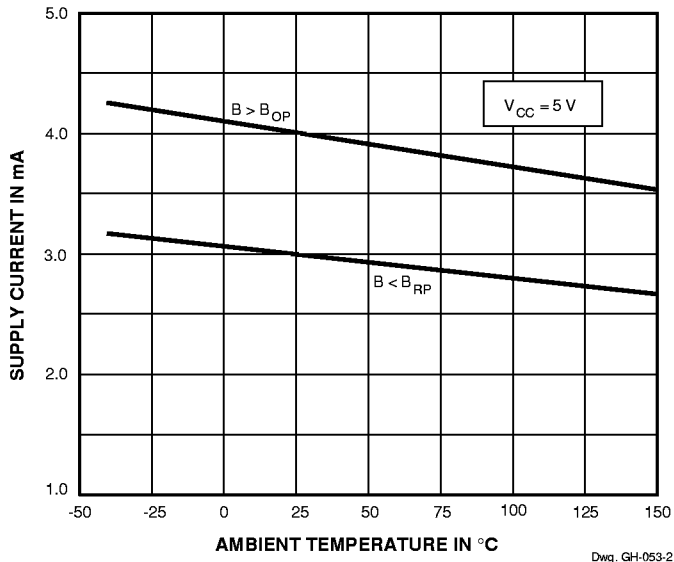

# ATS535JSB AND ATS535SSB PROGRAMMABLE, TRUE POWER-ON, HALL-EFFECT PROXIMITY SENSORS

## FUNCTIONAL DESCRIPTION

**Chopper-Stabilized Technique.** These devices use a proprietary dynamic offset cancellation technique, with an internal high-frequency clock to reduce the residual offset voltage of the Hall element that is normally caused by device overmolding, temperature dependencies, and thermal stress. This technique produces devices that have an extremely stable quiescent Hall output voltage, are immune to thermal stress, and have precise recoverability after temperature cycling. This technique will also slightly degrade the device output repeatability.

The Hall element can be considered as a resistor array similar to a Wheatstone bridge. A large portion of the offset is a result of the mismatching of these resistors. The chopper-stabilizing technique cancels the mismatching of the resistors by changing the direction of the current flowing through the Hall plate and Hall voltage measurement taps, while maintaining the Hall-voltage signal that is induced by the external magnetic flux. The signal is, then, captured by a sample-and-hold circuit.

**Operation.** The output of these devices switches low (turns ON) when a magnetic field (south pole) perpendicular to the Hall sensor exceeds the operate point threshold ( $B_{OP}$ ). After turn-ON, the output is capable of sinking 25 mA and the output voltage is  $V_{OUT(SAT)}$ . When the magnetic field is reduced below the release point ( $B_{RP}$ ), the device output goes high (turns OFF). The difference in the magnetic operate and release points is the hysteresis ( $B_{hys}$ ) of the device. This built-in hysteresis allows clean switching of the output even in the presence of external mechanical vibration and electrical noise.

**Applications.** It is strongly recommended that an external bypass capacitor be connected (in close proximity to the Hall sensor) between the supply and ground of the device to reduce both external noise and noise generated by the chopper-stabilization technique.

Many other methods of operation are possible. Extensive applications information on magnets and Hall-effect sensors is also available in the *Allegro Electronic Data Book AMS-702* or *Application Note 27701*, or

[www.allegromicro.com](http://www.allegromicro.com)

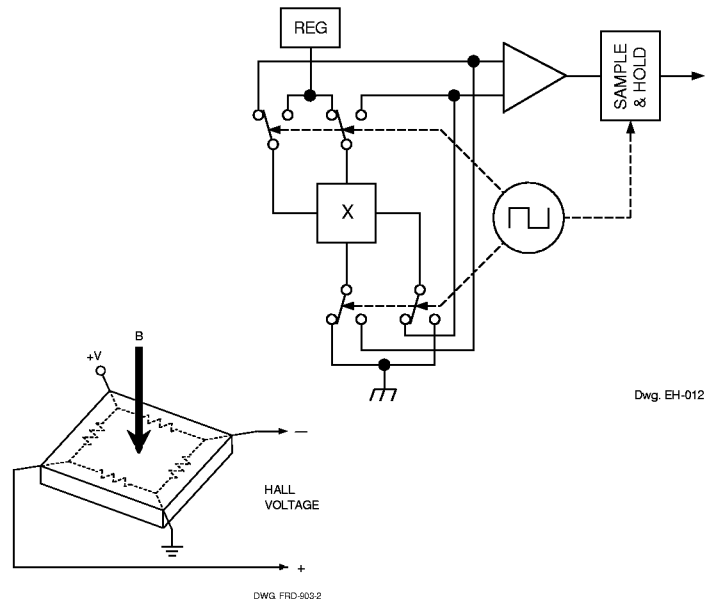

Dwg. EH-012

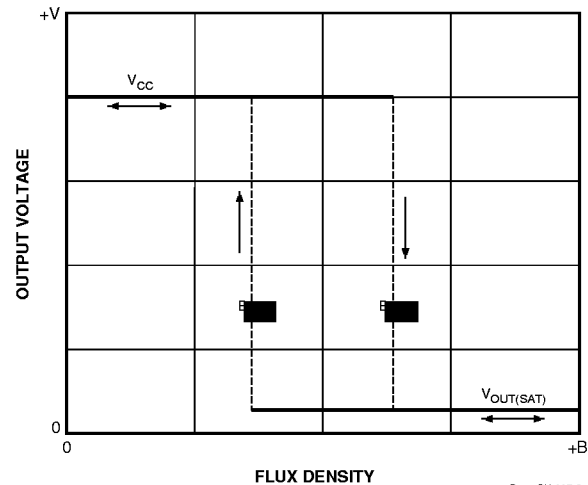

Dwg. GH-007-2

**ATS535JSB AND ATS535SSB  
PROGRAMMABLE, TRUE  
POWER-ON, HALL-EFFECT  
PROXIMITY SENSORS**

**PROGRAMMING PROTOCOL**

The ATS535JSB and ATS535SSB operate points are programmed by serially addressing the device through the supply terminal (pin1). After the correct operate point is determined, the device programming bits are selected and then a “lock” set to prevent any further (accidental) programming.

**Program Enable.** To program the device, a sequence of pulses is used to activate/enable the addressing mode as shown in figure 1. This sequence of a  $V_{PP}$  pulse, at least seven  $V_{PH}$  pulses, and a  $V_{PP}$  pulse with no supply interruptions, is designed to prevent the device from being programmed accidentally (for example, as a result of noise on the supply line).

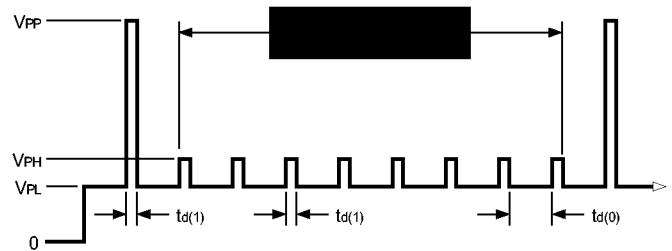

**Figure 1 — Program enable**

Dwg. WH-013

**PROGRAMMING PROTOCOL over operating temperature range.**

Characteristic	Symbol	Description	Limits			
			Min.	Typ.	Max.	Units
Programming Voltage	$V_{PL}$	Minimum voltage during programming	4.5	5.0	5.5	V
	$V_{PH}$		9.0	10	11	V
	$V_{PP}$		20	23	25	V
Programming Current	$I_{PP}$	Max. supply current during programming	–	250	–	mA
Pulse Width	$t_{d(0)}$	OFF time between bits	20	–	–	$\mu$ s
	$t_{d(1)}$	Enable, address, program, or lock bit ON time	20	–	–	$\mu$ s
	$t_{dP}$	Program pulse ON time	100	300	–	$\mu$ s
Pulse Rise Time	$t_r$	$V_{PL}$ to $V_{PH}$ or $V_{PP}$	11	–	–	$\mu$ s
Pulse Fall Time	$t_f$	$V_{PH}$ or $V_{PP}$ to $V_{PL}$	5.0	–	–	$\mu$ s

NOTE: Typical data is at  $T_A = +25^\circ\text{C}$  and is for design information only.



115 Northeast Cutoff, Box 15036  
Worcester, Massachusetts 01615-0036 (508) 853-5000

# ATS535JSB AND ATS535SSB PROGRAMMABLE, TRUE POWER-ON, HALL-EFFECT PROXIMITY SENSORS

**Address Determination.** The operate point is adjustable in 64 increments. With the appropriate target or gear\* in position, the 64 switch points are sequentially selected (figure 2) until the required operate point is reached. Note that the difference between the operate point and the release point (hysteresis) is a constant for all addresses.

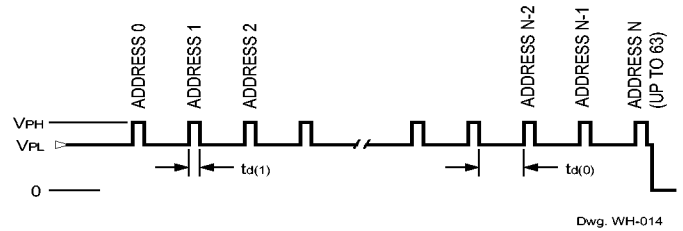

**Figure 2 — Address determination**

**Set-Point Programming.** After the desired set-point address is determined (0 through 63), each bit of the equivalent binary address is programmed individually. For example, as illustrated in figure 3, to program address code 5 (binary 000101), bits 1 and 3 need to be programmed. Each bit is programmed during the wide  $V_{PP}$  pulse and is not reversible.

**Lock Programming.** After the desired set point is programmed, the program lock is then activated (figure 4) to prevent further programming of the device.

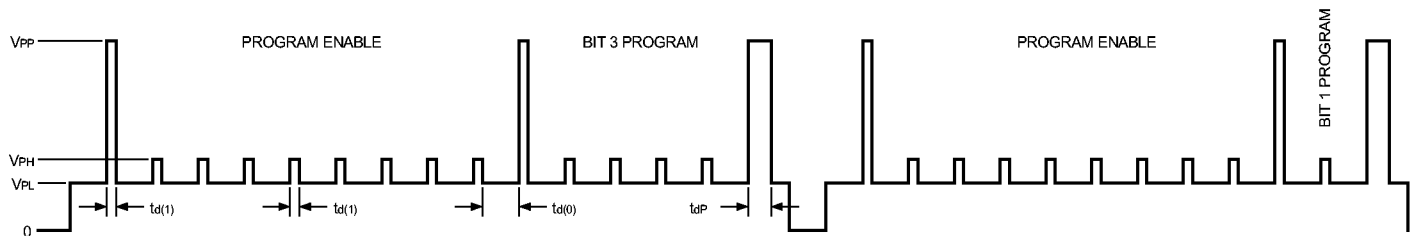

**Figure 3 — Set-point programming**

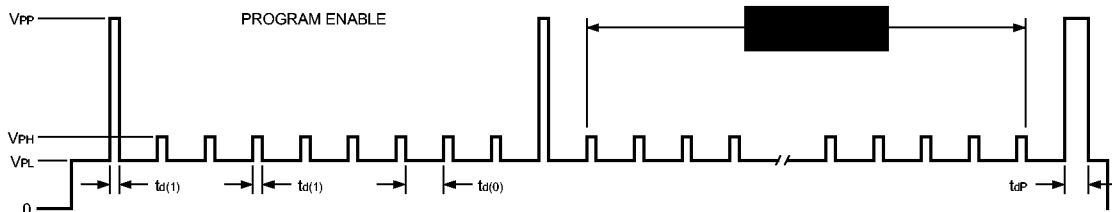

**Figure 4 — Lock programming**

\* In application, the terms “gear” and “target” are often interchanged. However, “gear” is preferred when motion is transferred.

**ATS535JSB AND ATS535SSB  
PROGRAMMABLE, TRUE  
POWER-ON, HALL-EFFECT  
PROXIMITY SENSORS**

**CRITERIA FOR DEVICE QUALIFICATION**

All Allegro sensors are subjected to stringent qualification requirements prior to being released to production. To become qualified, except for the destructive ESD tests, no failures are permitted.

Qualification Test	Test Method and Test Conditions	Test Length	Samples Per Lot	Comments
Temperature Humidity Bias Life	JESD22-A101, T <sub>A</sub> = 85°C, RH = 85%	1000 hrs	77	Device biased for minimum power
Bias Life	JESD22-A108, T <sub>A</sub> = 150°C, T <sub>J</sub> = 165°C	1000 hrs	77	
(Surge Operating Life)	JESD22-A108, T <sub>A</sub> = 175°C, T <sub>J</sub> = 190°C	168 hrs	77	
Autoclave, Unbiased	JESD22-A102, T <sub>A</sub> = 121°C, 15 psig	96 hrs	77	
High-Temperature (Bake) Storage Life	JESD22-A103, T <sub>A</sub> = 170°C	1000 hrs	77	
Temperature Cycle	JESD22-A104	1000 cycles	77	-55°C to +150°C
ESD, Human Body Model	CDF-AEC-Q100-002	Pre/Post Reading	3 per test	Test to failure All leads > TBD





# ATS535JSB AND ATS535SSB PROGRAMMABLE, TRUE POWER-ON, HALL-EFFECT PROXIMITY SENSORS

## APPLICATIONS INFORMATION

**Operation From a Regulated Power Supply.** These devices require minimal protection circuitry during operation from a low-voltage regulated line. The on-chip voltage regulator provides immunity to power supply variations between 4.25 V and 26 V. However, even while operating from a regulated line, some supply and output filtering is required to provide immunity to coupled and injected noise on the supply line. A basic RC low-pass circuit ( $R_1C_1$ ) on the supply line and an optional output capacitor ( $C_2$ ) is recommended for operation in noisy environments. Because the device has an open-collector output, an output pull-up resistor ( $R_L$ ) must be included either at the sensor output (pin 2) or by the signal processor input.

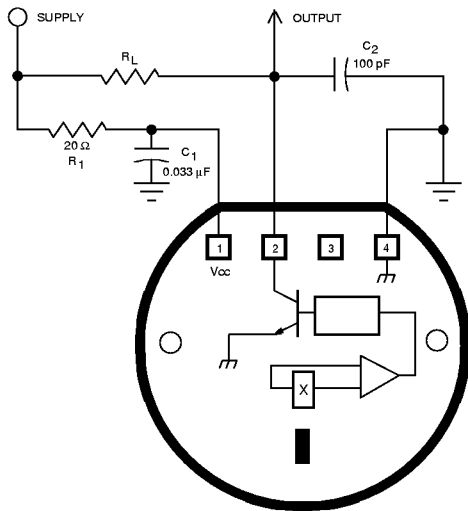

Dwg. EH-008-5

**Operation From an Unregulated Power Supply.** In automotive applications, where the device receives its power from an unregulated supply such as the battery, full protection is generally required so that the device can withstand the many supply-side transients. Specifications for such transients vary between car manufacturers, and protection-circuit design should be optimized for each application. In the circuit below, a simple Zener-controlled regulator is constructed using discrete components. The RC low-pass filter on the supply line ( $R_1C_1$ ) and a low-value supply bypass capacitor ( $C_S$ ) can be included, if necessary, so as to minimize susceptibility to EMI/RFI. The npn transistor should be chosen with sufficiently high forward breakdown voltage so as to withstand supply-side transients. The series diode should be chosen with sufficiently high reverse breakdown capabilities so as to withstand the most negative transient. The current-limiting resistor ( $R_Z$ ) and the Zener diode should be sized for power dissipation requirements.

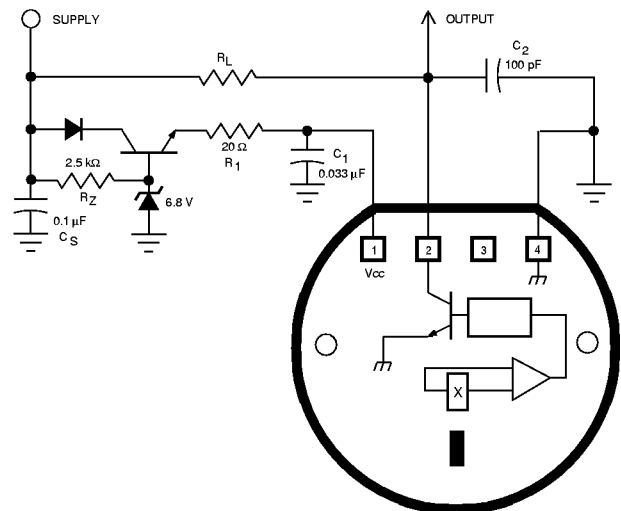

Dwg. EH-008-4

**ATS535JSB AND ATS535SSB  
PROGRAMMABLE, TRUE  
POWER-ON, HALL-EFFECT  
PROXIMITY SENSORS**

**MECHANICAL INFORMATION**

Component	Material	Function	Units
Sensor Face	Thermoset epoxy	Maximum temperature	170°C*
Plastic Housing	Thermoplastic PBT	264 psi deflection temp. (DTUL) 66 psi deflection temp. (DTUL) Approximate melting temperature	204°C 216°C 225°C
Flame Class Rating	—	—	UL94V-0
Leads	Copper	—	—
Lead Finish	90/10 tin/lead solder plate	—	†
Lead Pull	—	—	8 N

\* Temperature excursions to 225°C for 2 minutes or less are permitted.

† All industry-accepted soldering techniques are permitted for these subassemblies provided the indicated maximum temperature for each component (e.g., sensor face, plastic housing) is not exceeded. Reasonable dwell times, which do not cause melting of the plastic housing, should be used.

**Sensor Location (in millimeters)**

(sensor location relative to package center is the design objective)

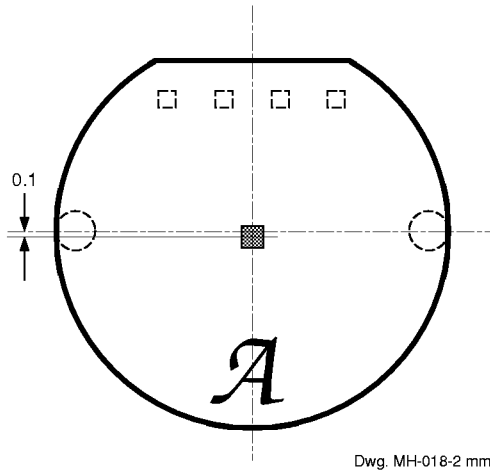

**Lead Cross Section (in millimeters)**

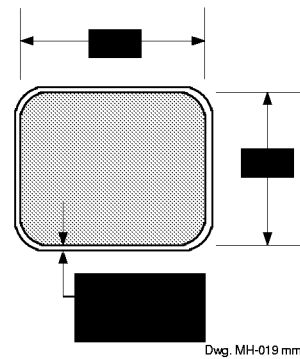

**ATS535JSB AND ATS535SSB**  
**PROGRAMMABLE, TRUE**  
**POWER-ON, HALL-EFFECT**  
**PROXIMITY SENSORS**

**DIMENSIONS IN MILLIMETERS**

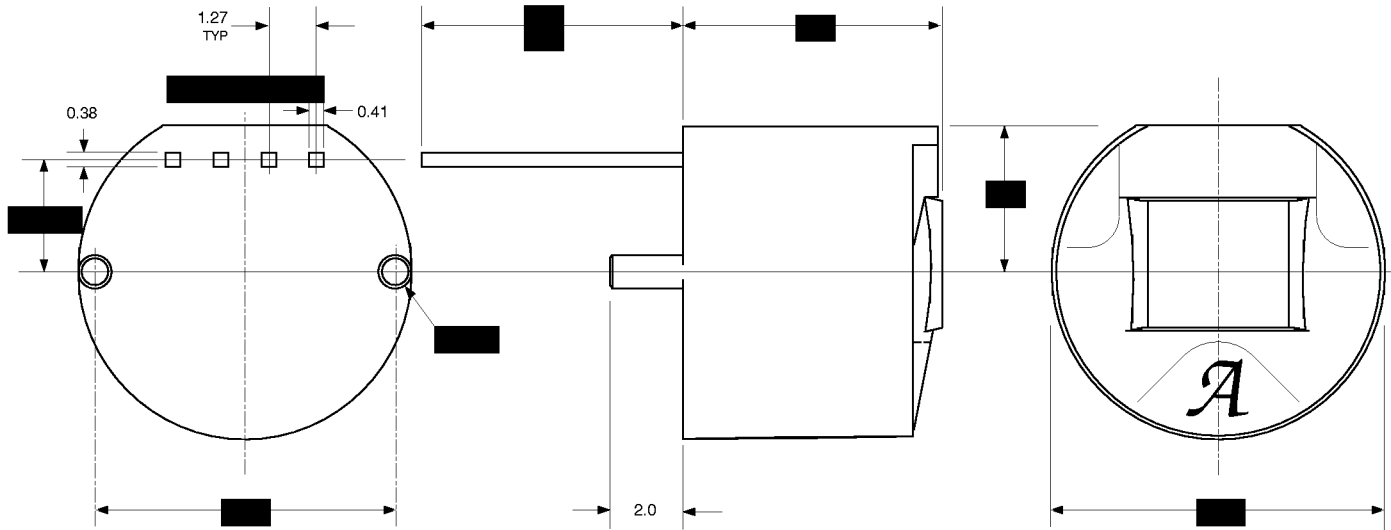

Dwg. MH-017-1B mm

Tolerances, unless otherwise specified: 1 place  $\pm 0.1$  mm, 2 places  $\pm 0.05$  mm.

**ATS535JSB AND ATS535SSB**  
**PROGRAMMABLE, TRUE**  
**POWER-ON, HALL-EFFECT**  
**PROXIMITY SENSORS**

*Allegro MicroSystems, Inc. reserves the right to make, from time to time, such departures from the detail specifications as may be required to permit improvements in the design of its products.*

*The information included herein is believed to be accurate and reliable. However, Allegro MicroSystems, Inc. assumes no responsibility for its use; nor for any infringements of patents or other rights of third parties which may result from its use.*



115 Northeast Cutoff, Box 15036  
Worcester, Massachusetts 01615-0036 (508) 853-5000