

PM-CSXX CURRENT SENSE TRANSFORMERS

- * Designed for Switch Mode Power Supply Applications
- * Frequency Range from 10KHz to 200KHz
- * Fully Encapsulated Construction

- * Tapped and Untapped Versions
- * 2500Vrms Minimum Isolation Voltage
- * Primary Lead Included

ELECTRICAL SPECIFICATIONS AT 25°C - OPERATING TEMPERATURE RANGE -40°C TO +80°C

CONTROL VALUES				REFERENCE VALUES				CALC. VALUES		SCHEMATIC
PART NUMBER	URNS $N_s \pm 1\%$	INDUCTANCE L_s (mH Min.)	DCR R_s (Ohms Max.)	I_{pk} (Amps)	R_T (Ohms)	K_V (Volt/Amp)	DROOP (%)	FLUX FACTOR K_B	LOSS FACTOR K_L	
PM-CS01	50	5.0	0.70	35	15	0.30	2.4	273.97×10^3	3.31×10^{-9}	A
PM-CS02	100	20.0	1.40	50	50	0.50	2.0	68.49×10^3	3.33×10^{-9}	A
PM-CS03	200	80.0	4.50	50	200	1.00	2.0	17.12×10^3	3.35×10^{-9}	A
PM-CS04	300	180.0	11.00	75	300	1.00	1.4	7.61×10^3	3.37×10^{-9}	A
PM-CS05	50ct	5.0	0.50	35	15	0.30	2.4	273.97×10^3	3.31×10^{-9}	B
PM-CS06	100ct	20.0	1.00	50	50	0.50	2.0	68.49×10^3	3.33×10^{-9}	B
PM-CS07	200ct	80.0	2.00	50	200	1.00	2.0	17.12×10^3	3.35×10^{-9}	B
PM-CS08	300ct	180.0	11.00	75	300	1.00	1.4	7.61×10^3	3.37×10^{-9}	B

REFER TO CALCULATION EXAMPLE FOR PM-CSXX SERIES ON PAGE 2 OF THIS DATA SHEET.

- 1) REFERENCE VALUES ARE FOR UNIPOLAR OPERATION @ 50KHz, 40% DUTY CYCLE ($D_{max} = .40$).
- 2) THE MAXIMUM USABLE PEAK SENSE CURRENT (I_{pk}) IS DEPENDENT ON CORE SATURATION FACTORS AND SHOULD BE EVALUATED FOR THE ACTUAL OPERATING CONDITIONS. SEE APPLICATION DATA AND EXAMPLE ON PAGE 51.
- 3) THE MAXIMUM RECOMMENDED OPERATING FLUX DENSITY (B_{op}) @ AN OPERATING TEMPERATURE OF 105°C IS 2000 GAUSS.
- 4) THE TERM. RESISTOR (R_T) CAN BE VARIED TO ADJUST THE OPERATING FLUX DENSITY (B_{op}), DROOP, AND SCALE FACTOR (K_V).
- 5) THE SCALE FACTOR (K_V) IS PROPORTIONAL TO THE TERMINATING RESISTOR (R_T) AND IS EQUAL TO 1VOLT/AMP WHEN $R_T = N_s$
- 6) SECONDARY INDUCTANCE IS MEASURED AT 20KHz, 1.0VRMS.

SCHEMATIC

SCHEMATIC "A"

WHITE DOT
DENOTES PIN #1

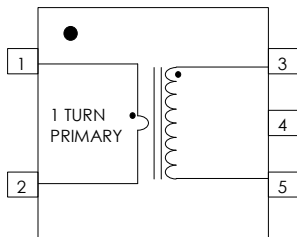

UNUSED PINS MAY BE OMITTED

SCHEMATIC "B"

WHITE DOT
DENOTES PIN #1

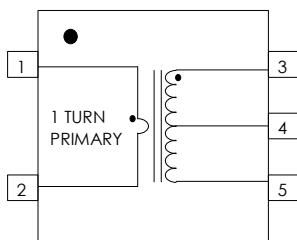

Specifications subject to change without notice.

MECHANICAL

PHYSICAL Dimensions in inches (mm)

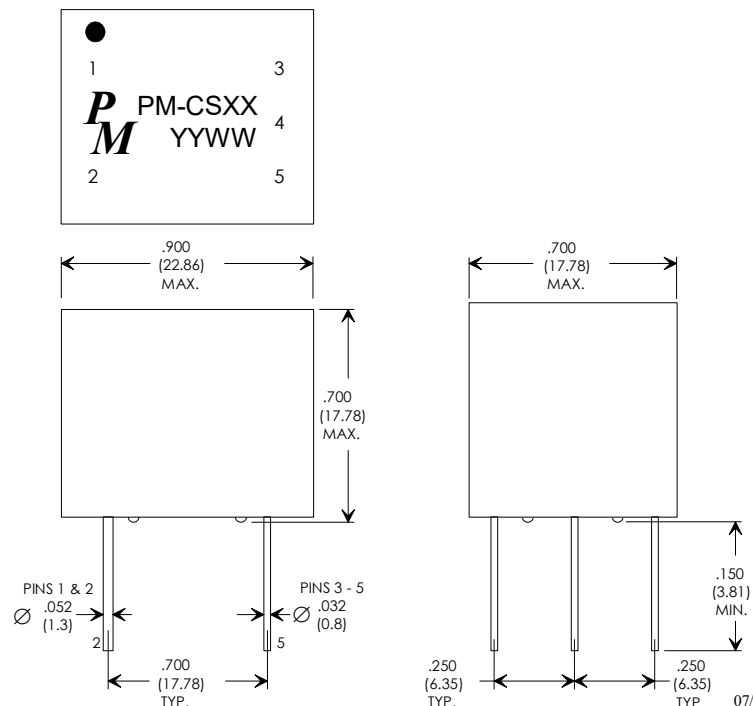

07/09/21

PM-CSXX CURRENT SENSE TRANSFORMERS

- * High Current - Primary Rated for 35 Amps RMS
- * Frequency Range from 50KHz to 500KHz

- * Designed for automatic pick and place
- * Maximum height = 10mm

ELECTRICAL SPECIFICATIONS AT 25°C - OPERATING TEMPERATURE RANGE -40°C TO +130°C

PART NUMBER	TURNS $N_s \pm 1\%$	SEC INDUCTANCE (mH Min.)	SEC DCR (Ohms Max.)	PRI CURRENT (Amps)	HIPOT (Vrms)
PM-CS21	1 : 30	0.50	0.34	35	500
PM-CS22	1 : 50	1.40	0.57	35	500
PM-CS23	1 : 70	2.70	0.80	35	500
PM-CS24	1 : 100	5.60	1.50	35	500
PM-CS25	1 : 200	22.0	5.00	35	500
PM-CS26	1 : 300	50.0	12.0	35	500

SCHEMATIC

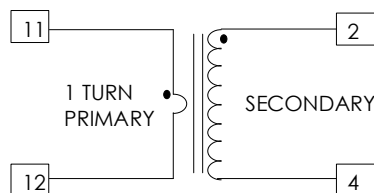

MECHANICAL

PHYSICAL Dimensions in inches (mm)

RECOMMEND LAYOUT

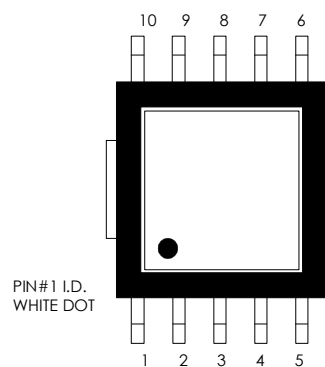
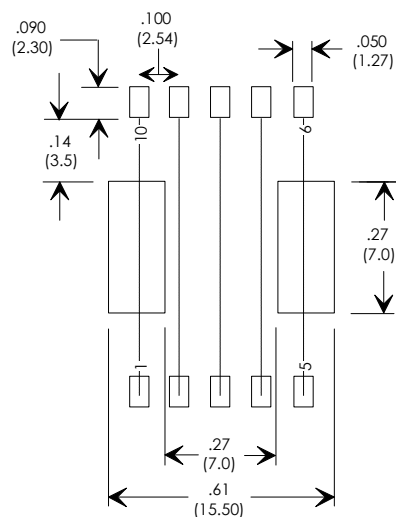

PM PM-CSXX
YYWW

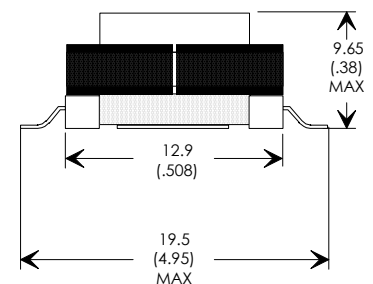
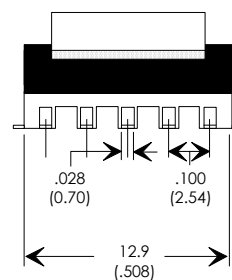

PM-CSXX CURRENT SENSE TRANSFORMERS

- * High Current -Primary Rated
- * Frequency Range up to 1MHz

- * Designed for automatic pick and place
- * Withstands Solder Reflow

ELECTRICAL SPECIFICATIONS AT 25°C - OPERATING TEMPERATURE RANGE -40°C TO +130°C

PART NUMBER	TURNS $N_s \pm 1\%$	SEC INDUCTANCE (μH Min.)	SEC DCR (Ohms Max.)	PRI CURRENT (Amps)	HIPOT (Vrms)
PM-CS31	1 : 70	980	4.75	6	500
PM-CS32	1 : 40	320	1.14	6	500
PM-CS33	1 : 30	180	0.87	6	500
PM-CS34	1 : 20	80	0.55	6	500
PM-CS35	1 : 50	500	1.50	6	500
PM-CS36	1 : 60	720	1.75	6	500
PM-CS37	1 : 100	2000	5.50	6	500
PM-CS38	1 : 125	3000	6.50	6	500
PM-CS39	1 : 200	6700	35.0	10	500

MECHANICAL

SCHEMATIC

PHYSICAL Dimensions in mm (inches)

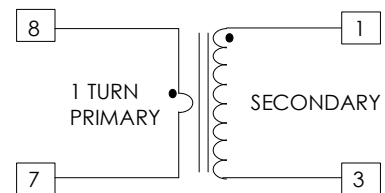
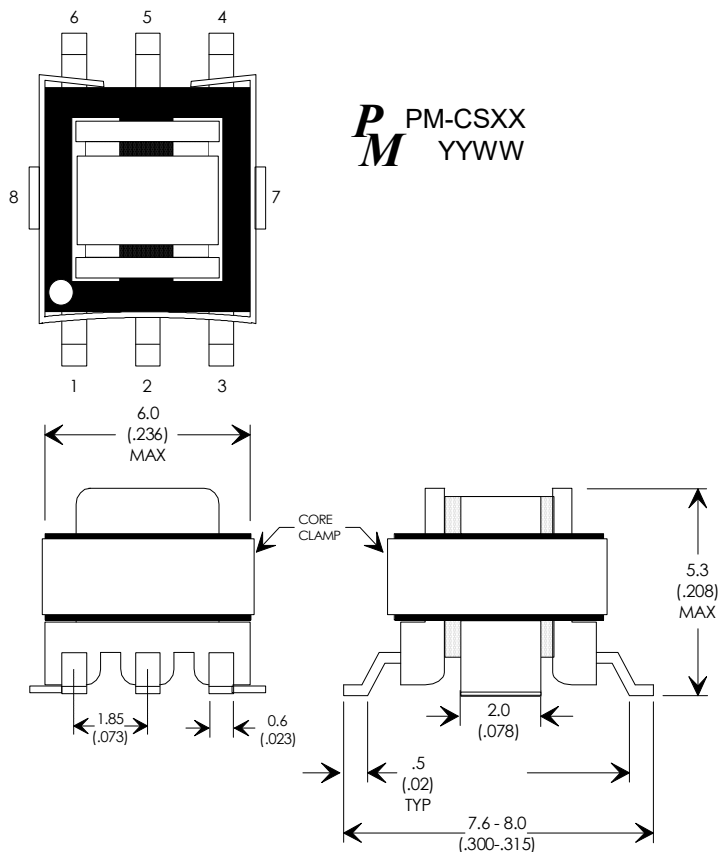

RECOMMEND LAYOUT

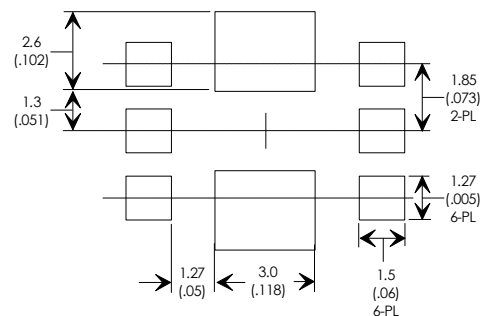

Specifications subject to change without notice.

07/09/21

PM-CSXX CURRENT SENSE TRANSFORMERS

- * High Current -Primary Rated
- * Frequency Range up to 1MHz

- * Designed for automatic pick and place
- * Withstands Solder Reflow

ELECTRICAL SPECIFICATIONS AT 25°C - OPERATING TEMPERATURE RANGE -40°C TO +130°C

PART NUMBER	TURNS $N_s \pm 1\%$	SEC INDUCTANCE ($\mu\text{H Min.}$)	SEC DCR (Ohms Max.)	PRI CURRENT (Amps)	HIPOT (Vrms)
PM-CS40	1 : 20	65	0.50	20	500
PM-CS41	1 : 30	145	0.75	20	500
PM-CS42	1 : 40	264	1.05	20	500
PM-CS43	1 : 50	410	1.65	20	500
PM-CS44	1 : 60	590	2.00	20	500
PM-CS45	1 : 70	805	3.00	20	500
PM-CS46	1 : 100	1650	5.40	20	500
PM-CS47	1 : 125	2570	6.70	20	500
PM-CS48	1 : 200	6600	33.30	20	500

MECHANICAL

SCHEMATIC

PM-CSXX
YYWW

RECOMMEND LAYOUT

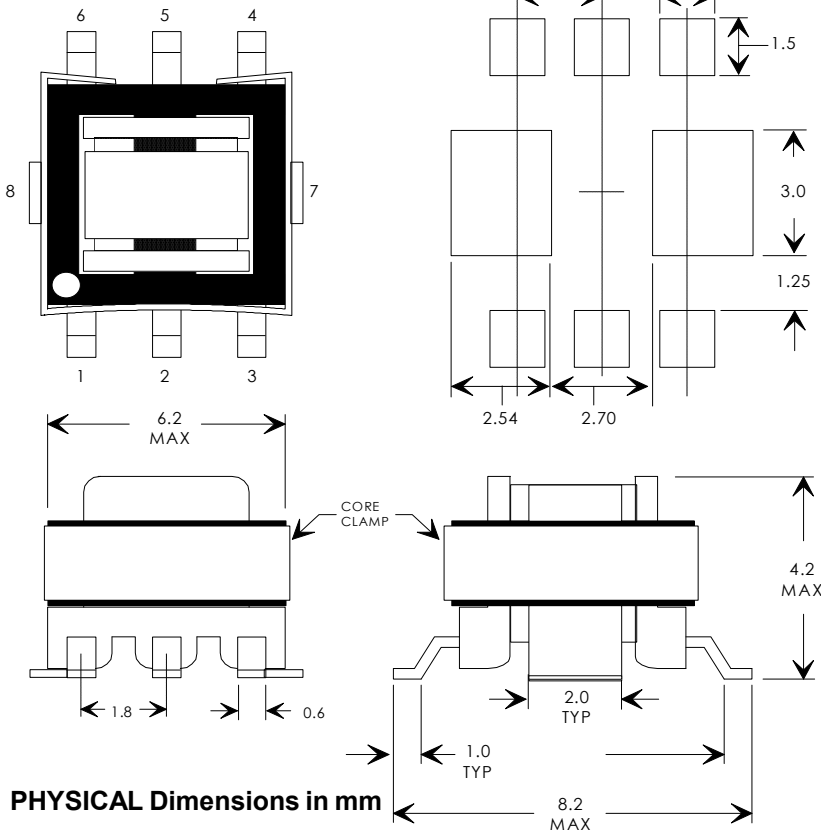
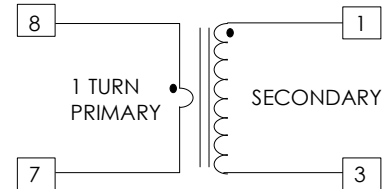

PHYSICAL Dimensions in mm

Specifications subject to change without notice.

07/09/21

PM-CSXX CURRENT SENSE TRANSFORMERS

- * High Current -Primary Rated
- * Operating Frequency Range up to 100KHz

- * Designed for automatic pick and place
- * Withstands Solder Reflow

ELECTRICAL SPECIFICATIONS AT 25°C - OPERATING TEMPERATURE RANGE -40°C TO +130°C

PART NUMBER	TURNS $N_s \pm 1\%$	SEC INDUCTANCE (mH Min.)	SEC DCR (Ohms Max.)	PRI CURRENT (Amps)	HIPOT (Vrms)
PM-CS50	1 : 30	0.20	0.25	20.0	500
PM-CS51	1 : 50	0.55	0.65	20.0	500
PM-CS52	1 : 70	1.10	1.40	20.0	500
PM-CS53	1 : 100	2.10	3.00	20.0	500
PM-CS54	1 : 200	9.00	8.00	20.0	500
PM-CS55	1 : 300	20.0	20.0	20.0	500

MECHANICAL

SCHEMATIC

P PM-CSXX
M YYWW

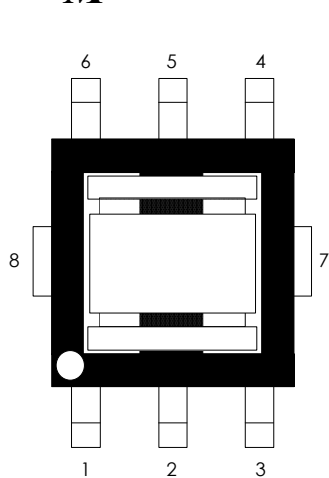

RECOMMEND LAYOUT

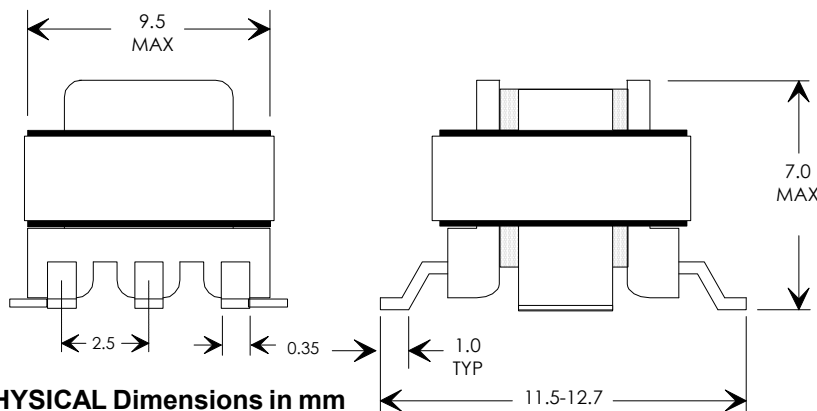
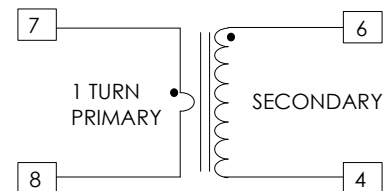
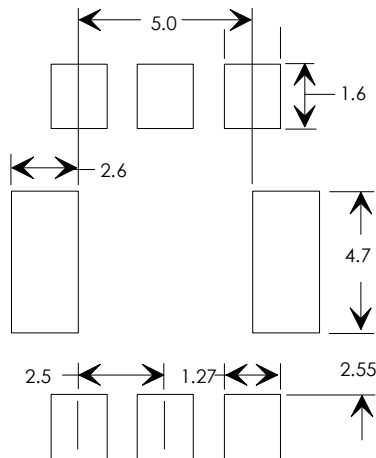

PHYSICAL Dimensions in mm

PM-CSXX CURRENT SENSE TRANSFORMERS

- * High Current -Primary Rated
- * Operating Frequency Range 50kHz-500kHz

ELECTRICAL SPECIFICATIONS AT 25°C - OPERATING TEMPERATURE RANGE -25°C TO +125°C

PART NUMBER	URNS RATIO Pri:Sec1:Sec2	PRI INDUCTANCE @0.1V, 15kHz (mH Min.)	PRI DCR (Ohms Max.)	SEC'S DCR (OhmS mAX.)	HIPOT (Vrms)
PM-CS70	40:1:1	3.2	0.56	5.0	3000
PM-CS71	50:1:1	5.0	0.70	5.0	3000
PM-CS72	100:1:1	20.0	1.40	5.0	3000
PM-CS73	200:1:1	80.0	4.50	5.0	3000
PM-CS74	300:1:1	180.0	11.0	5.0	3000

MECHANICAL

SCHEMATIC

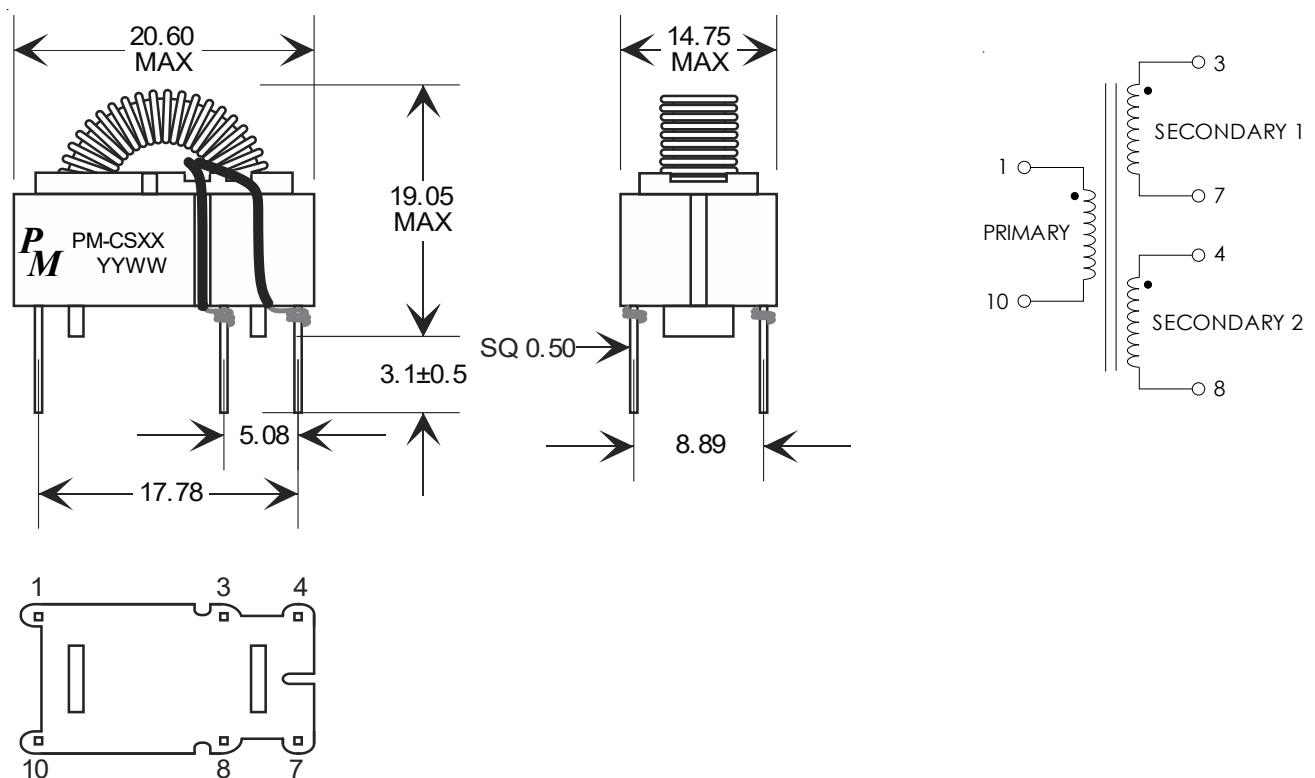

PHYSICAL Dimensions in mm
Unless otherwise specified, Tolerance: +/-0.5

APPLICATION EXAMPLE

APPLICATION EXAMPLE

GIVEN:

Part# = PM-CI02

Peak Current (I_{PK}) = 30.0 Amps

Terminating Resistor (R_T) = 100 Ohms

Operating Frequency (f) = 100KHz

Duty Cycle (Dmax) = .40 (40% on time)

CALCULATE OPERATING FLUX DENSITY

From the Table the FLUX FACTOR is:

$$K_B = 68.49 \times 10^3$$

Flux Utilization Constant (K_F) is:

1.0 For Unipolar Operation

2.0 For Bipolar Operation

THEN:

$$B_{OP} = K_B \times I_{PK} \times R_T \times (D_{max} / K_F \times f)$$

$$= 68.49 \times 10^3 \times 30 \times 100 \times (.4 / 1 \times 100 \times 10^3)$$

$$= 822 \text{ gauss (OK less than 2000 gauss)}$$

CALCULATE PULSE DROOP

From the Table the Secondary Inductance is:

$$L_S = 20 \text{mHy Minimum}$$

Note: The actual droop is dependent on the actual L_S in the circuits environment.

$$\text{Droop Exponent (D)} = R_T \times D_{max} / (L_S \times f)$$

$$= 100 \times .4 / (20 \times 10^{-3} \times 100 \times 10^3)$$

$$= 0.020$$

THEN:

$$\%_{\text{Droop}} = (1 - e^{-D}) \times 100$$

$$= 1.98 \%$$

OK less than 10%

(Depending on the application

Droop to 20% may be acceptable)

CALCULATE THE SCALE FACTOR

From the Table the Secondary Turns are:

$$N_S = 100$$

THEN:

$$K_V = R_T / N_S$$

$$= 100 / 100$$

$$= 1 \text{ volt/amp}$$

ESTIMATE ERROR DUE TO LOSSES

From the Table the Secondary DCR is:

$$R_S = 1.40 \text{ Ohms Maximum}$$

From the Table the approximate Loss Factor is:

$$K_L = 3.33 \times 10^{-9}$$

Note: The loss factor (K_L) is valid approximation from 10KHz to 200KHz

Secondary Copper Losses are:

$$P_{\text{loss}_S} = (I_{PK} / N_S)^2 \times R_S$$

$$= (30/100)^2 \times 1.40$$

$$= 0.126 \text{ Watt}$$

Core losses are:

$$P_{\text{loss}_C} = K_L^2 \times f^{1.621} \times B_{OP}^{2.569}$$

$$= (3.33 \times 10^{-9})^2 \times (100 \times 10^3)^{1.621} \times 822^{2.569}$$

$$= 0.0435 \text{ Watt}$$

Output Power is:

$$P_{\text{out}_S} = (I_{PK} / N_S)^2 \times R_T$$

$$= (30/100)^2 \times 100$$

$$= 9.00 \text{ Watt}$$

THEN:

$$\%_{\text{Error}} = [(P_{\text{loss}_S} + P_{\text{loss}_C}) / P_{\text{out}_S}] \times 100$$

$$= [(0.126 + 0.0435) / 9] \times 100$$

$$= 1.88 \%$$