Multimedia DCT-CODEC

Description

The 29C810 is an Application Specific Standard Product (ASSP) integrating 2 times two dimensional Discrete Cosine Transform unit (DCT) and 20 KGates on the same die.

The DCTs are implemented as standard cell blocks in the die. The rest of the circuit has 20 KGates which are user configurable and different support functions can be implemented on this Gate Area. The device is packaged in the 160 PQFP package with 148 user configurable I/Os.

The DCT has a parallel computing architecture and it is based on the modified CHEN algorithm. The DCT processes 8×8 pixel or coefficient blocks. The blocks can be scanned line by line, column by column or in zig-zag scanning mode. The available formats are 8, 9 bits for pixels and 12 bits for coefficients.

The Gate Area can be customized using MHS gate array library with commercially available CAE systems.

Features

- User configurable discrete-cosine-transform-CODEC (DCT)
- JPEG, MPEG and H261 compatible ASSP device
- Includes : 2 × DCT standard cell block and 20 K gates
- Max frequency 40 MHz
- PQFP 160 package, 148 user configurable I/Os
- Support functions : Huffman decoder, quantization, bus-interface
- DCT : two dimensional DCT, forward and inverse operation, complies with H261 accuracy

29C810

Block Diagram : 2 Dimensional DCT-block with parallel architecture

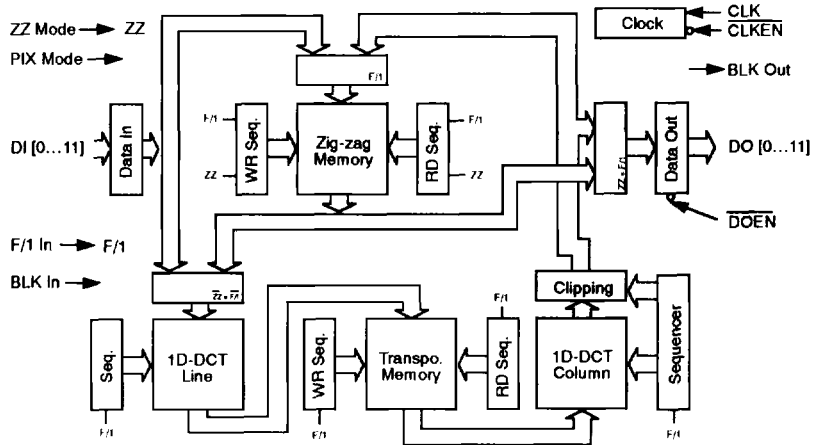

29C810 Typical Layout

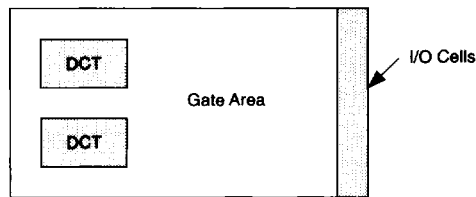

Applications

- Multimedia ADD-on cards
- Security systems
- Medical systems
- Videophones and video conference systems
- Tele diagnostic systems

The information contained herein is subject to change without notice. No responsibility is assumed by MATRA MHS SA for using this publication and/or circuits described herein : nor for any possible infringements of patents or other rights of third parties which may result from its use.