

RED INDICATES ORIGINAL

DATA CONTAINED IN THIS DOCUMENT IS PROPRIETARY TO TROMPETER ELECTRONICS INC. AND SHALL NOT BE DISCLOSED, COPIED OR USED FOR PROCUREMENT OR MANUFACTURE WITHOUT EXPRESS WRITTEN PERMISSION.

REV		EO	DESCRIPTION	REVISIONS		105-1904	SH 1
A1			PRODUCTION RELEASE	DWN	APPROVED		DATE
				R L			

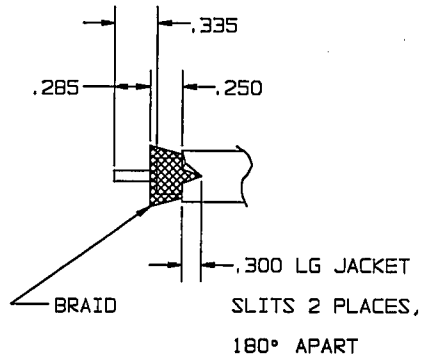

CABLE STRIPPING

SCALE: NONE

1. PLACE "WRENCH CRIMP" NUT ONTO CABLE & PUSH BACK
2. CUT .285 DIM, THEN .250 DIM, FOLD BACK BRAID AND MAKE .335 CUT, BRING BRAID FORWARD

3. 75 OHM MINIATURE COAXIAL (F TYPE) CABLE PLUG FOR BELDEN CABLE NO. 89292

2. FINISH: TFS-1A (NICKEL)

1. ALL DIM ARE IN INCHES

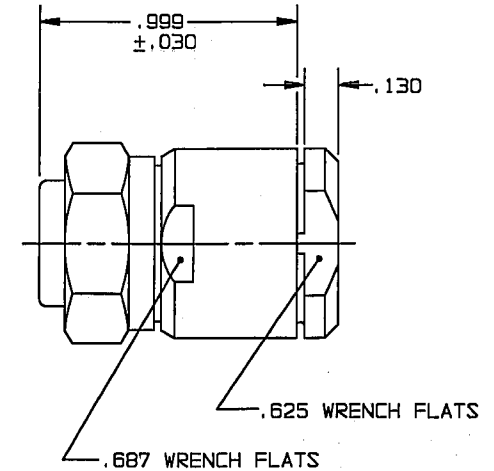
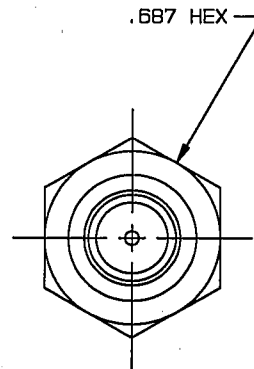

QTY	DESCRIPTION		PART NUMBER	ITEM		
	TOL UNLESS SPECIFIED .XX ± .XXX ± .005 .XXXX ± ANGLES ±		TROMPETER ELECTRONICS, INC.	PL130- 89292		
DWN	R L	3/5/99			MATERIAL	CODE IDENT
CHK		3-8-99		14949	105-1904	A
ENGR						
NEXT ASSY	APPR	JL	3-9-99	SCALE 2/1	DATE 3/9/99	SHEET 1C