

DO NOT SCALE FROM THIS PRINT

DESIGNED & DIMENSIONED IN INCHES[MILLIMETERS]

PRF18-J-C-EE-405-SD-X

- SERIES
-18: 1.85MM
- GENDER
-J: JACK
- TYPE
-C: CABLE
- PACKAGING
-B: BULK (IN INCREMENTS OF 50)
(BLANK): STANDARD PACKAGING
- TERMINATION
-D: DIRECT SOLDER
- ORIENTATION
-S: STRAIGHT
- CABLE TYPE
-405: RG-405 SEMI RIGID
- PLATING
-EE: 50µ" EXTRA HEAVY GOLD
CENTER CONTACT, 50µ" EXTRA HEAVY GOLD OUTER CONTACT

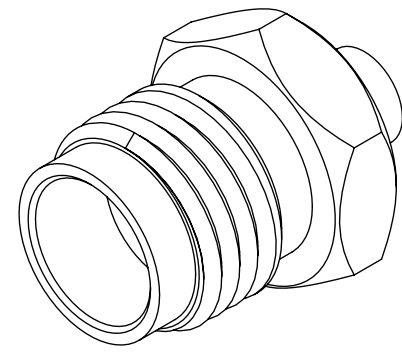
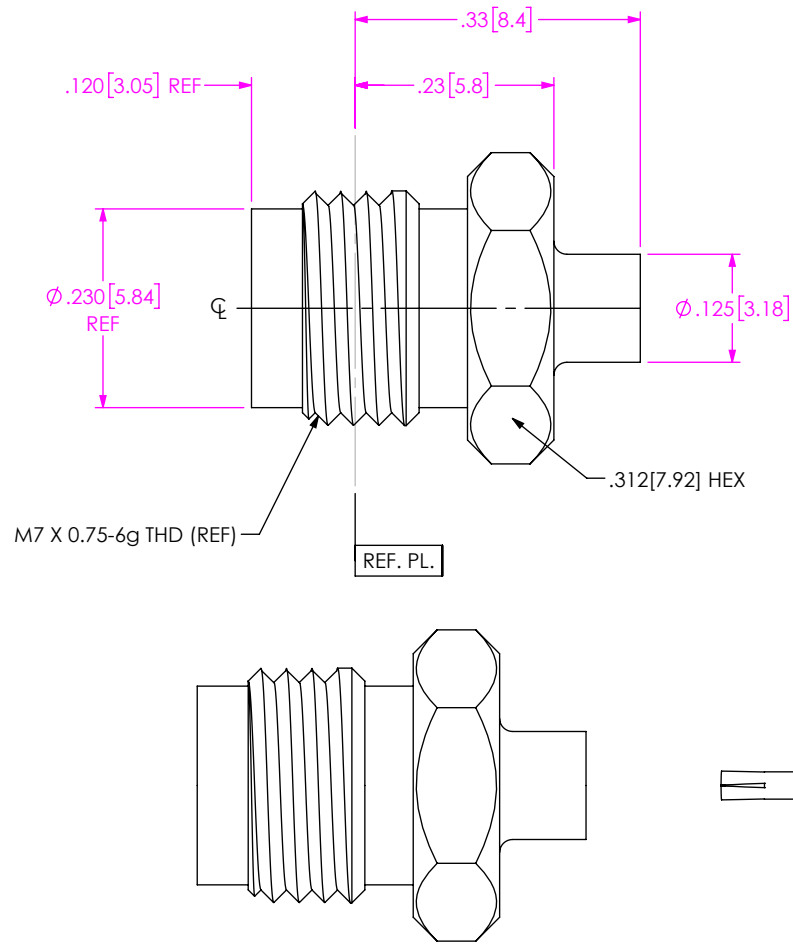

- NOTES:
- MATERIAL:
BODY, CONTACT: BERYLLIUM COPPER
 - FINISH:
BODY, CONTACT: 50µ" MIN. GOLD OVER 50µ" MIN. NICKEL PLATE
 - PERFORMANCE:
IMPEDANCE: 50 Ω
FREQUENCY: DC TO 65 GHz
VSWR: 1.18:1 MAXIMUM
INSERTION LOSS: 0.03 x √f(GHz)
DWV: 900 Vrms
 - PCI P/N: 3231
 - BULK PACKAGING OPTION (-B) FOR ORDERS IN INCREMENTS OF 50 PCS.

EXPLODED VIEW
NOT TO SCALE
(FOR CLARITY ONLY)

F:\DWG\MISC\MKTG\PRF18-J-C-EE-405-SD-X-MKT.SLDDRW

UNLESS OTHERWISE SPECIFIED, DIMENSIONS ARE IN INCHES. TOLERANCES ARE: DECIMALS ANGLES .XX: ±.02[0.5] 1° .XXX: ±.005[0.13] .XXXX: ±.0005[0.013]	* PROPRIETARY NOTE * THIS DOCUMENT CONTAINS CONFIDENTIAL AND PROPRIETARY INFORMATION AND ALL DESIGN, MANUFACTURING, REPRODUCTION, USE, PATENT RIGHTS AND SALES RIGHTS ARE EXPRESSLY RESERVED BY SAMTEC, INC. THIS DOCUMENT SHALL NOT BE DISCLOSED, IN WHOLE OR PART, TO ANY UNAUTHORIZED PERSON OR ENTITY NOR REPRODUCED, TRANSFERRED OR INCORPORATED IN ANY OTHER PROJECT IN ANY MANNER WITHOUT THE EXPRESS WRITTEN CONSENT OF SAMTEC, INC.	
		520 PARK EAST BLVD, NEW ALBANY, IN 47150 PHONE: 812-944-6733 FAX: 812-948-5047 e-Mail info@SAMTEC.com code 55322
		MATERIAL: DO NOT SCALE DRAWING SHEET SCALE: 4.5:1 DESCRIPTION: 1.85MM JACK FOR RG-405 CABLE DWG. NO. PRF18-J-C-EE-405-SD-X BY: CANDY W 04/29/2019 SHEET 1 OF 2

CABLE APPLICATION VIEWS

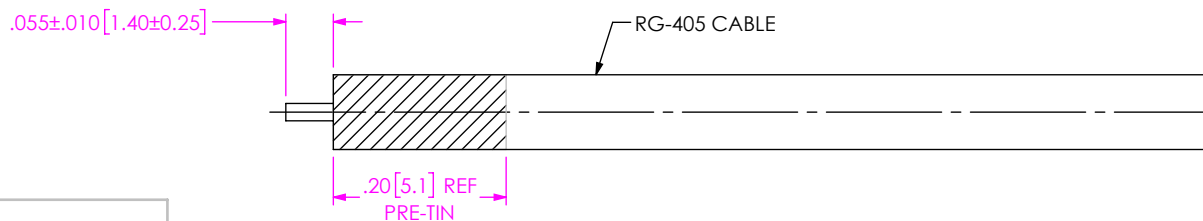

- 1A. TRIM CABLE JACKET & DIELECTRIC TO EXPOSE CENTER CONDUCTOR AS SHOWN (DO NOT NICK CENTER CONDUCTOR).
- 1B. PRE-TIN CABLE JACKET TO THE APPROXIMATE LENGTH SHOWN.

IN-PROCESS VIEW 1

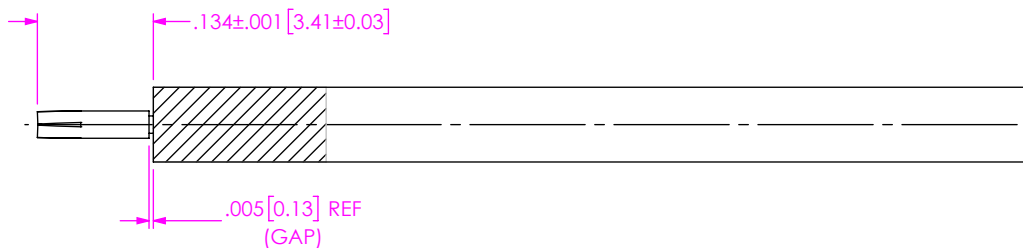

- 2. PRE-TIN CABLE CENTER CONDUCTOR AND SOLDER ON CONTACT TO DIMENSION SHOWN.

IN-PROCESS VIEW 2

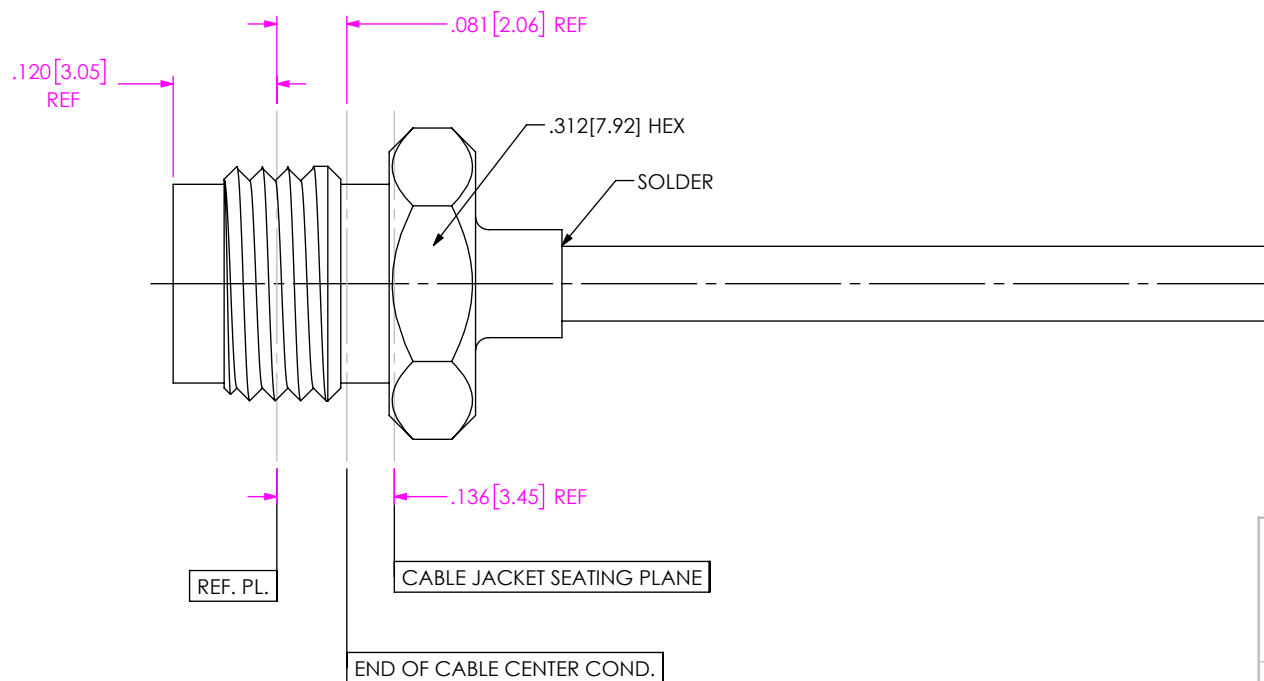

DISTANCE FROM END OF CABLE CENTER COND. TO REF. PL. IS .081 (REF.)

- 3A. INSERT CABLE/CONTACT SUB-ASSEMBLY INTO CONNECTOR UNTIL SEATED AND SOLDER WHERE INDICATED.
- 3B. GAGE INTERFACE USING APPROPRIATE GAGE (CONTACT RANGE .000/.003 SUB-FLUSH).

IN-PROCESS VIEW 3

PROPRIETARY NOTE
 THIS DOCUMENT CONTAINS CONFIDENTIAL AND PROPRIETARY INFORMATION AND ALL DESIGN, MANUFACTURING, REPRODUCTION, USE, PATENT RIGHTS AND SALES RIGHTS ARE EXPRESSLY RESERVED BY SAMTEC, INC. THIS DOCUMENT SHALL NOT BE DISCLOSED, IN WHOLE OR PART, TO ANY UNAUTHORIZED PERSON OR ENTITY NOR REPRODUCED, TRANSFERRED OR INCORPORATED IN ANY OTHER PROJECT IN ANY MANNER WITHOUT THE EXPRESS WRITTEN CONSENT OF SAMTEC, INC.



520 PARK EAST BLVD, NEW ALBANY, IN 47150
 PHONE: 812-944-6733 FAX: 812-948-5047
 e-Mail: info@SAMTEC.com code 55322

DO NOT SCALE DRAWING
 SHEET SCALE: 4.5:1

DESCRIPTION: 1.85MM JACK FOR RG-405 CABLE
 DWG. NO. PRF18-J-C-EE-405-SD-X
 BY: CANDY W 04/29/2019 SHEET 2 OF 2