

NPN METAL CAN - SATURATED SWITCH (Cont'd.)

TYPE NO.	V <sub>CB</sub>	V <sub>CE</sub>	V <sub>EB</sub>	h <sub>FE</sub> at I <sub>C</sub>		V <sub>CE</sub>	V <sub>CE(s)</sub> at I <sub>C</sub>		f <sub>T</sub>	C <sub>ob</sub>	t <sub>on</sub>	t <sub>off</sub>	I <sub>CBO</sub> at V <sub>CB</sub>		CASE	
	V	V	V	min	ma	V	V	mA	MHz	pF	nS	nS	μA	V		
2N2242	15	15	5	40	120	10	1	0.3	10	250	6	—	25	—	—	TO-18
2N2368	40	15	4	20	40	10	1	0.25	0.85	400	4	12	15	0.4	20	TO-18
2N2369	40	15	4	40	120	10	1	0.25	0.85	500	4	12	18	0.4	20	TO-18
2N2369A	40	15	4	40	120	10	1	0.25	1.5	50	4	12	18	—	—	TO-18
2N2410	30	30	5	30	120	150	10	0.45	150	200	11	—	55	—	—	TO-5
2N2475	15	6	4	30	150	20	0.4	0.4	1	600	3	20	15	0.5	5	TO-18
2N2481	40	15	5	40	120	10	1	.25	10	300	5	40	55	.05	20	TO-5
2N2501	40	20	6	50	150	10	1	.20	10	350	4	—	—	—	—	TO-5
2N2651	40	20	5	25	—	10	1	.25	10	350	4	35	75	.03	20	TO-18
2N2710	40	20	5	40	—	10	1	.25	10	500	4	20	35	.03	20	TO-18
2N2784	15	6	4	40	120	10	0.5	0.26	3	1000	3	9	9	0.005	5	TO-18
2N2845	60	30	5	30	120	150	10	1.0	500	250	8	40	40	0.2	30	TO-18
2N2846	60	30	5	30	120	150	10	1.0	500	250	8	40	40	0.2	30	TO-5
2N2847	60	20	5	40	140	150	10	.75	500	250	8	25	40	0.2	30	TO-18
2N2848	60	20	5	40	140	150	10	.75	500	250	8	25	40	0.2	30	TO-5
2N3009	40	15	4	30	120	30	1	.18	30	350	5	15	25	.50	20	TO-18
2N3010	15	6	4	25	125	10	0.4	0.25	1	600	3	12	12	—	—	TO-18
2N3011	30	12	5	30	—	10	.35	.35	10	400	—	—	—	.01	5	TO-18
2N3013	40	15	4	30	120	30	0.4	0.28	100	350	5	5	15	25	—	TO-18
2N3014	40	20	5	30	120	30	0.4	0.35	100	350	5	16	25	—	—	TO-18
2N3015	60	30	5	30	120	150	10	0.4	150	250	8	—	60	0.2	30	TO-5
2N3210	40	15	5	30	120	10	5	0.5	100	400	4	15	20	—	—	TO-18
2N3252	60	30	5	30	90	500	1	0.5	500	200	12	—	30	0.5	40	TO-5
2N3253	75	40	5	25	75	375	1	0.6	500	175	12	—	30	0.5	60	TO-5
2N3444	80	50	5	20	60	500	1	0.6	500	150	12	—	30	0.5	60	TO-5
2N3554	60	30	5	25	100	750	10	0.7	750	150	25	50	105	—	—	TO-5
2N3633	15	6	4	50	150	10	0.5	0.21	3	1300	2.5	9	9	0.005	5	TO-18
2N3648	40	15	6	25	—	10	1	.25	10	450	4	16	18	.025	10	TO-46
2N3722	60	60	6	40	150	100	5	0.22	100	300	10	—	100	—	—	TO-5
2N3723	80	80	6	40	150	100	5	0.28	100	300	9	—	130	—	—	TO-5
2N3724	50	30	6	60	150	100	1	0.2	100	300	12	—	60	1.7	40	TO-5
2N3724A	50	30	6	60	150	100	1	0.2	100	300	12	—	60	0.5	40	TO-5
2N3725	80	50	6	60	150	100	1	0.4	300	300	10	—	60	1.7	60	TO-5
2N3725A	80	50	6	60	150	100	1	0.4	300	300	10	—	60	0.5	60	TO-5
2N3734	50	30	5	30	120	1000	1.5	0.5	500	300	9	—	60	—	—	TO-5
2N3735	75	50	5	20	80	1000	1.5	0.5	500	250	9	—	60	0.2	40	TO-5
2N3830	80	50	5	30	—	500	10	0.5	200	200	12	60	70	—	—	TO-5
2N3831	70	40	5	35	—	500	10	0.5	500	200	12	60	70	—	—	TO-5
2N4013	50	30	6	60	150	100	1	0.42	500	300	12	—	—	1.7	40	TO-18
2N4014	80	50	6	60	150	100	1	0.52	500	300	10	—	—	1.7	60	TO-18
2N4046	30	30	6	40	150	100	1	0.2	100	250	12	—	60	—	—	TO-5
2N4047	50	50	6	40	150	100	5	0.26	100	250	10	—	60	—	—	TO-5
2N4137	40	15	4	40	—	10	1	.35	10	500	4	—	—	—	—	TO-18

NPN METAL CAN - LOW NOISE LEVEL AMPLIFIER

TYPE NO.	V <sub>CB</sub>	V <sub>CE</sub>	V <sub>EB</sub>	h <sub>FE</sub> at I <sub>C</sub>		V <sub>CE</sub>	V <sub>CE(s)</sub> at I <sub>C</sub>		f <sub>T</sub>	C <sub>ob</sub>	NF	t <sub>off</sub>	I <sub>CBO</sub> at V <sub>CB</sub>		CASE	
	V	V	V	min	max	V	V	mA	MHz	pF	dB	nS	μA	V		
2N760	45	45	8	76	333	1	5	1.0	10	50	8	—	—	0.2	30	TO-18
2N760A	60	60	8	76	333	1	5	1.0	10	50	8	—	—	0.1	30	TO-18
2N929	45	45	5	40	120	.01	5	1.0	10	30	8	4	—	.01	45	TO-18
2N929A	60	45	6	40	120	.01	5	0.5	10	45	6	4	—	.02	45	TO-18
2N930	45	45	5	100	300	.01	5	1.0	10	30	8	3	—	.01	45	TO-18
2N930A	60	45	6	100	300	.01	5	0.5	10	45	6	3	—	.002	45	TO-18
2N930B	60	45	6	100	300	.01	5	0.5	10	45	6	3	—	—	—	TO-18
2N981	80	80	8	—	—	—	—	3.0	10	—	5	—	—	1.0	30	TO-18
2N2483	60	60	6	40	120	.01	5	.35	1.0	60	6	4	—	.01	45	TO-18
2N2484	60	60	6	100	500	.01	5	.35	1.0	60	6	3	—	.01	45	TO-18
2N2484A	60	60	6	100	500	.01	5	0.35	1.0	60	6	2.0	—	—	—	TO-18
2N2509	124	80	7	25	—	.01	5	1.0	5	45	6	7	—	.005	100	TO-18
2N2510	100	65	7	150	500	10	5	1.0	5	45	6	4	—	.005	80	TO-18
2N2511	80	50	7	240	750	10	5	1.0	5	45	6	4	—	.005	60	TO-18
2N2586	60	45	6	120	360	.01	5	0.5	10	45	7	3	—	.002	45	TO-18

# CASE OUTLINE DRAWINGS

D

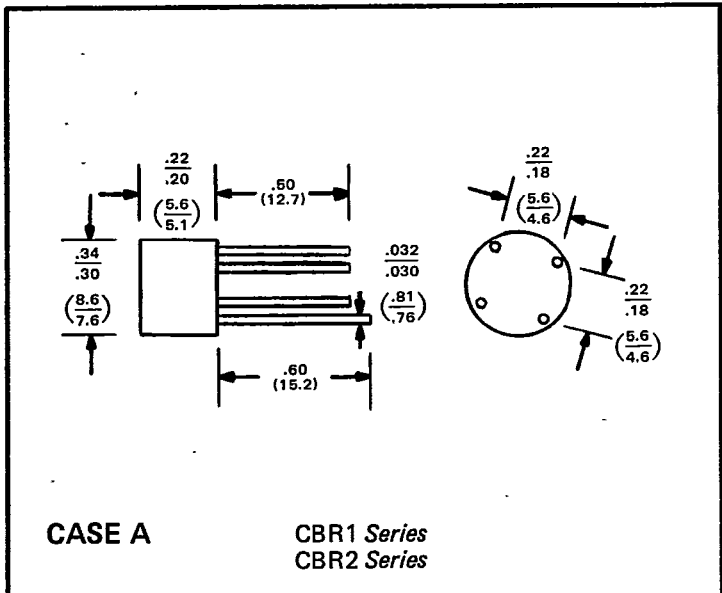

**CASE A**      CBR1 Series  
CBR2 Series

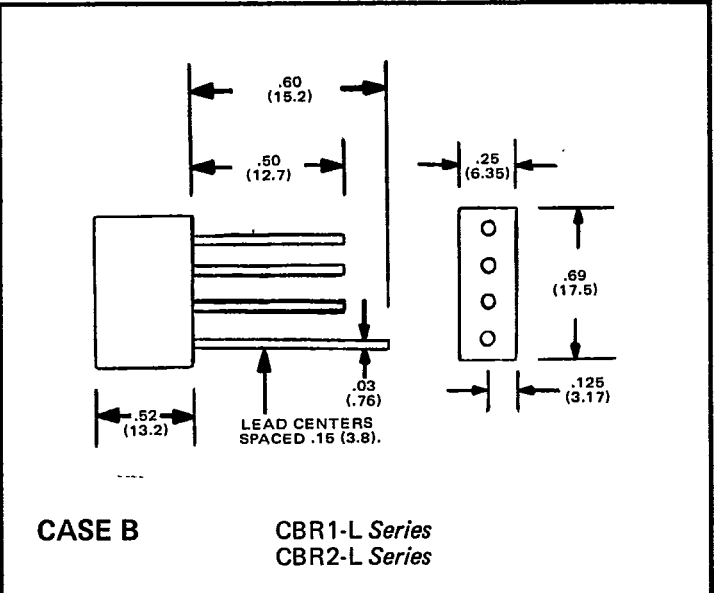

**CASE B**      CBR1-L Series  
CBR2-L Series

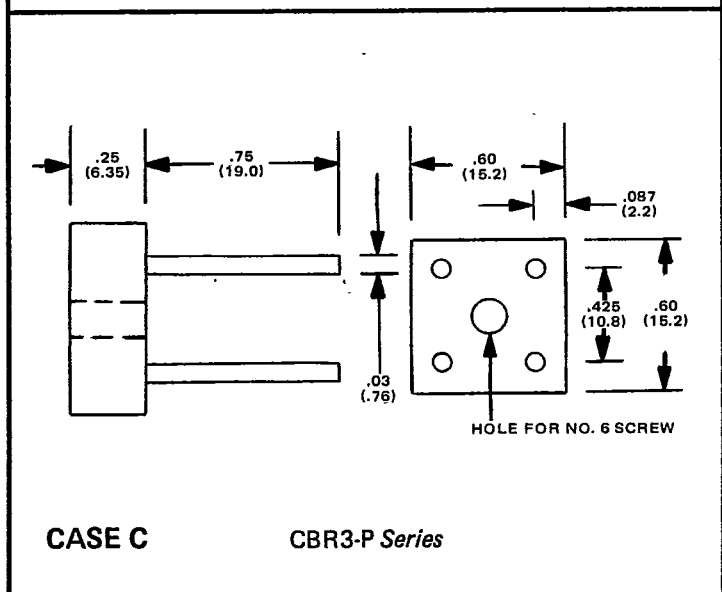

**CASE C**      CBR3-P Series

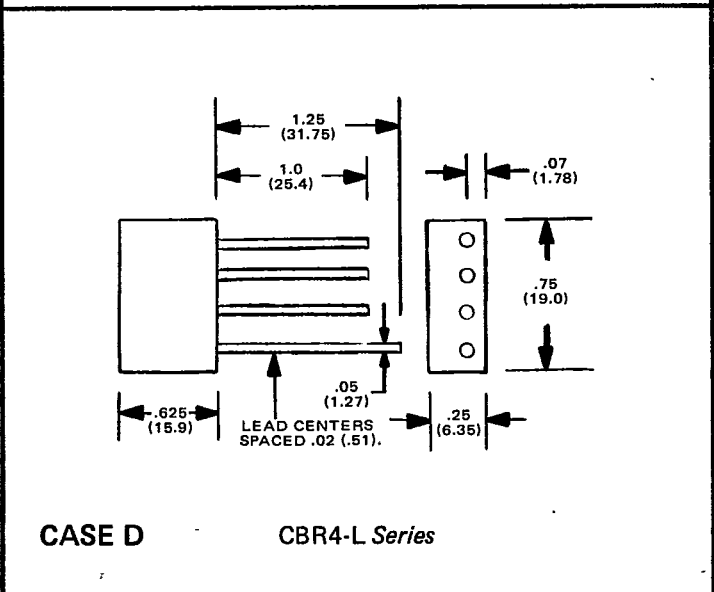

**CASE D**      CBR4-L Series

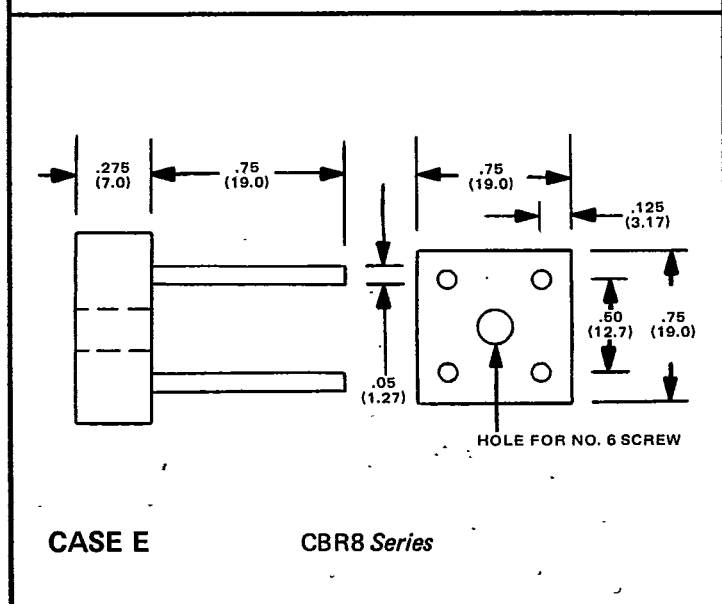

**CASE E**      CBR8 Series

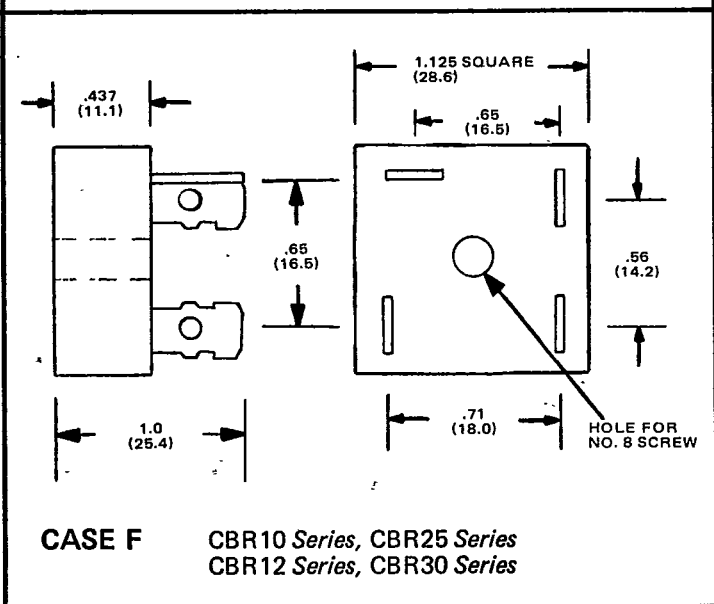

**CASE F**      CBR10 Series, CBR25 Series  
CBR12 Series, CBR30 Series

All Dimensions in Inches (Millimeters)  
Drawings Not To Scale

f

