

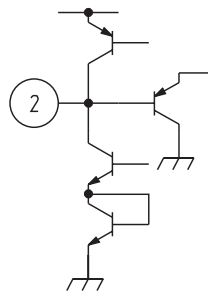

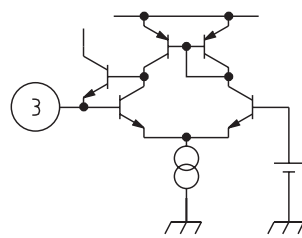
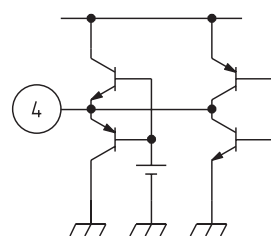

**Pin Description**

Pin no.	Pin name	Internal equivalent circuit diagram	Function
1	V <sub>CC</sub>		Power supply voltage pin. Impresses 5V.
2	SC		VCO integration pin Free run frequency determined by external capacitor between Pin 2 and GND, and external resistor between Pin 3 and GND.
3	VCO		VCO input pin Pin 4 output is input via external loop filter.
4	LPF		Phase comparator output pin.
5	GND		GND
6	V <sub>IN</sub>		Signal input pin Inputs video signal.
7	V.SYNC		V. SYNC output pin Outputs vertical sync signal separated from input video signal.
8	H.SYNC		H. SYNC output pin Outputs horizontal sync signal synchronized to input video signal, except for vertical feedback interval. For no signal, outputs free run frequency horizontal sync signal.

**Absolute Maximum Ratings** (Ta=25°C)

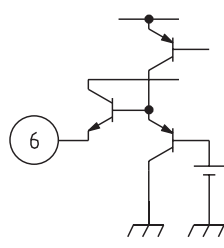
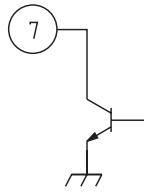
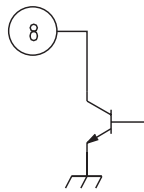
Item	Symbol	Ratings	Units
Storage temperature	T <sub>STG</sub>	-40~+125	°C
Operating temperature	T <sub>OPR</sub>	-20~+75	°C
Power supply voltage	V <sub>CC</sub> max.	7	V
Allowable loss	P <sub>d</sub>	300 *	mW

\* Package : SOP-8C

**Electrical Characteristics** (Except where noted otherwise, Ta=25°C, V<sub>CC</sub>=5.0V, SW1=a, SW2=a)

Item	Symbol	Measurement circuit	Measurement conditions	Min.	Typ.	Max.	Units
Operating power supply voltage	V <sub>CC</sub>	V <sub>CC</sub>		4.5	5.0	5.5	V
Consumption current	I <sub>d</sub>	I <sub>d</sub>	SW1 : b		4.4	7.0	mA
Minimum sync separation operating current	I <sub>SEPA</sub>	I <sub>IN</sub>	SW1 : c, VR1 : H→L *1	15	30	60	μA
Free-running frequency	f <sub>o</sub>	TP1	SW1 : b	14.7	15.7	16.7	kHz
Horizontal sync signal acquisition range	f <sub>CAP</sub>	TP1	V <sub>IN</sub> : signal 1, 15.73kHz SW2 : b *2 *3	2.1	2.7		kHz
H. sync pulse width	t <sub>w1</sub>	TP1	V <sub>IN</sub> : signal 1, 15.73kHz *4	4.3	4.7	5.1	μs
H. sync delay time	t <sub>d1</sub>	TP1	V <sub>IN</sub> : signal 1, 15.73kHz *4	-0.3	0.2	0.7	μs
H. sync output voltage L	V <sub>L1</sub>	TP1	V <sub>IN</sub> : signal 1, 15.73kHz *4		0.2	0.4	V
H. sync output voltage H	V <sub>H1</sub>	TP1	V <sub>IN</sub> : signal 1, 15.73kHz *4	4.8	5.0		V
V. sync pulse width	t <sub>w2</sub>	TP2	V <sub>IN</sub> : staircase wave 1V <sub>P-P</sub> *5	140	200	260	μs
V. sync delay time	t <sub>d2</sub>	TP2	V <sub>IN</sub> : staircase wave 1V <sub>P-P</sub> *5	6.0	10.0	20.0	μs
V. sync output voltage L	V <sub>L2</sub>	TP2	V <sub>IN</sub> : staircase wave 1V <sub>P-P</sub> *5		0.2	0.4	V
V. sync output voltage H	V <sub>H2</sub>	TP2	V <sub>IN</sub> : staircase wave 1V <sub>P-P</sub> *5	4.8	5.0		V

Notes :

- \*1 Minimum sync separation operating current measurement  
Given SW1 : c, change VR1 from high to low, and measure current flowing on I<sub>IN</sub> when TP2 output switches from high to low.
- \*2 Signal 1 : Rectangular wave signal with 0.3V amplitude and pulse width 4.7μs

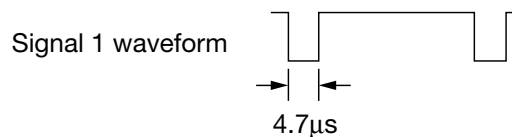

- \*3 Measuring horizontal sync signal pull-in range  
Given SW1 : a and SW2 : b, with TP1 waveform not synchronized to signal 1, adjust VR2 so that they are synchronized. Next, switch SW1 to b, and measure TP1 output free run frequency. The horizontal signal pull-in range is the smaller of the measured value and the difference from 15.73kHz.

\*4 H. SYNC measurement

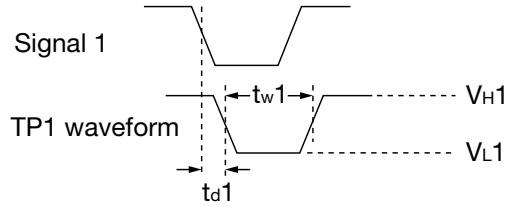

\*5 V. SYNC measurement

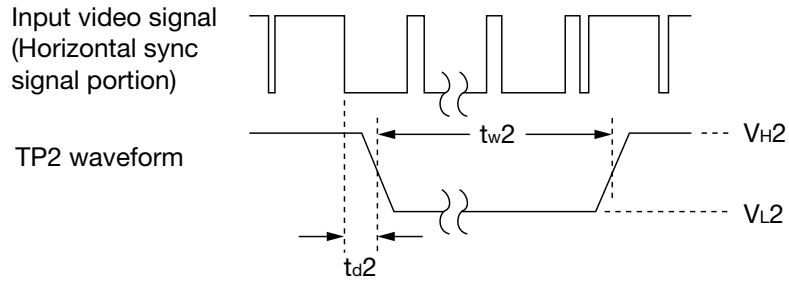

Measuring Circuit

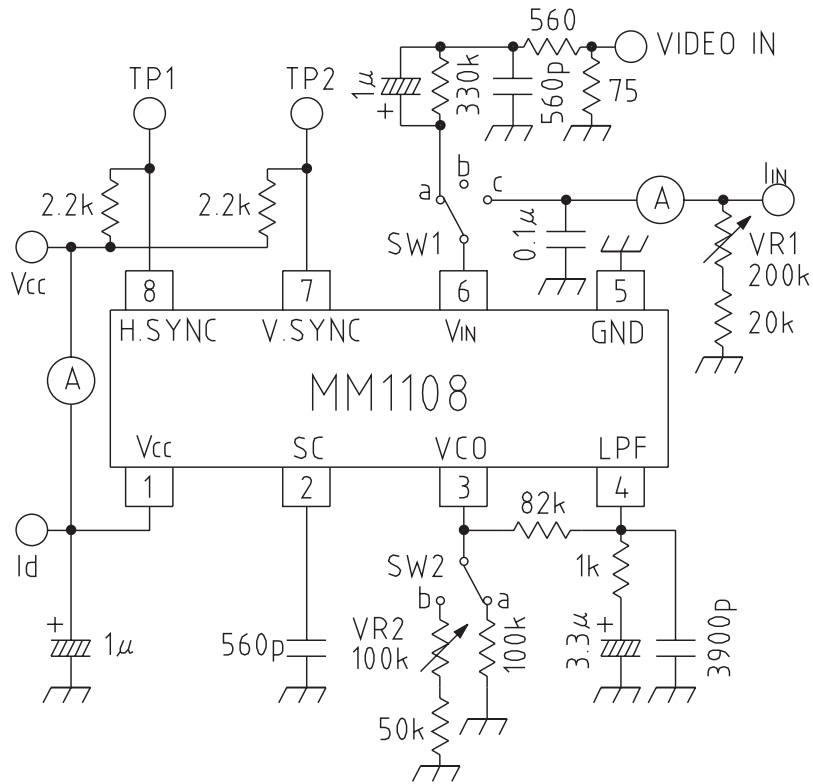

Application Circuits

Application Circuit 1

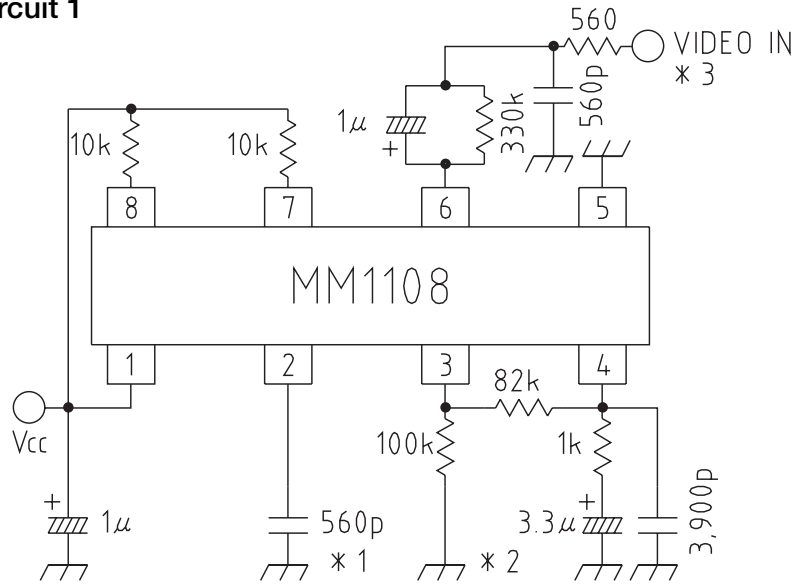

- Note1 : \* 1 Temperature characteristics CH,  $\pm 5\%$   
 \* 2 Metal film resistor,  $\pm 1\%$   
 \* 3 Input signal sync tip must be less than 1V

Application Circuit 2

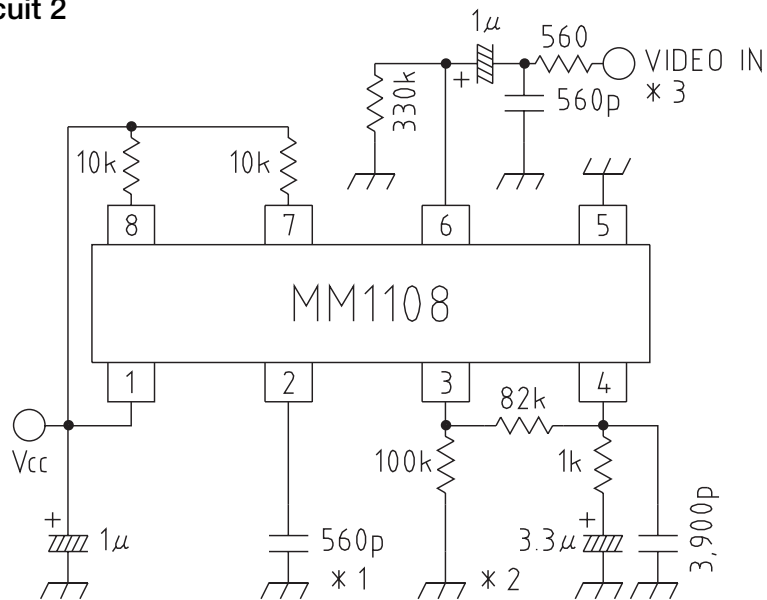

- Note2 : \* 1 Temperature characteristics CH,  $\pm 5\%$   
 \* 2 Metal film resistor,  $\pm 1\%$   
 \* 3 Note 1 \* 3 does not apply.  
 Pin 6 is clamped to approximately 2.5V