

## HIGH ISOLATION VOLTAGE DARLINGTON TRANSISTOR TYPE MULTI OPTOCOUPLER SERIES

PS2562-1,-2, -4  
PS2562L-1,-2, -4

### FEATURES

- **HIGH ISOLATION VOLTAGE**  
BV: 5000 V<sub>r.m.s.</sub>: normal speck products
- **HIGH CURRENT TRANSFER RATIO**  
CTR: 2000% TYP
- **HIGH SPEED SWITCHING**  
 $t_r, t_f = 100 \mu\text{s}$  TYP
- **ISOLATED CHANNELS PER EACH PACKAGE**

### DESCRIPTION

PS2562-1, -2 and -4 and PS2562L-1, -2 and -4 are optically coupled isolators containing a GaAs light emitting diode and an NPN silicon Darlington connected photo transistor. PS2562-1 and -2 and -4 are in a plastic DIP (Dual In-line Package) and PS2562L-1 and -2 and -4 are lead bending type (Gull-wing) for surface mount.

### APPLICATIONS

Interface circuit for various instrumentations and control equipment.

- **AC LINE / DIGITAL LOGIC**
- **DIGITAL LOGIC / DIGITAL LOGIC**
- **TWISTED PAIR LINE RECEIVER**
- **TELEPHONE / TELEGRAPH LINE RECEIVER**
- **HIGH FREQUENCY POWER SUPPLY FEEDBACK CONTROL**
- **RELAY CONTACT MONITOR**
- **POWER SUPPLY MONITOR**



### ELECTRICAL CHARACTERISTICS (T<sub>A</sub> = 25°C)

PART NUMBER				PS2562-1, -2, -4 PS2562L-1, -2, -4		
	SYMBOLS	PARAMETERS	UNITS	MIN	TYP	MAX
Diode	V <sub>F</sub>	Forward Voltage, I <sub>F</sub> = 10 mA	V		1.17	1.4
	I <sub>R</sub>	Reverse Current, V <sub>R</sub> = 5 V	μA			5
	C	Junction Capacitance, V = 0, f = 1.0 MHz	pF		50	
Transistor	I <sub>CEO</sub>	Collector to Emitter Dark Current, V <sub>ce</sub> = 40 V, I <sub>F</sub> = 0	nA			400
	BV <sub>CEO</sub>	Collector to Emitter Breakdown Voltage, I <sub>c</sub> = 1 mA, I <sub>B</sub> = 0	V	40	60	
	BV <sub>ECO</sub>	Emitter to Collector Breakdown Voltage, I <sub>E</sub> = 100 μA, I <sub>B</sub> = 0	V	6	8	
Coupled	CTR	Current Transfer Ratio <sup>1</sup> , I <sub>F</sub> = 1 mA, V <sub>CE</sub> = 2 V	%	200	2000	
	V <sub>CE(sat)</sub>	Collector Saturation Voltage, I <sub>F</sub> = 1 mA, I <sub>c</sub> = 2 mA	V			1.0
	R <sub>1-2</sub>	Isolation Resistance, V <sub>IN-OUT</sub> = 1.0 kV	Ω	10 <sup>11</sup>		
	C <sub>1-2</sub>	Isolation Capacitance, V = 0, f = 1.0 MHz	pF		0.5	
	t <sub>r</sub>	Rise Time <sup>2</sup> , V <sub>CC</sub> = 10 V, I <sub>c</sub> = 10 mA, R <sub>L</sub> = 100 Ω	μs		100	
	t <sub>f</sub>	Fall Time <sup>2</sup> , V <sub>CC</sub> = 10 V, I <sub>c</sub> = 10 mA, R <sub>L</sub> = 100 Ω	μs		100	

#### Notes:

- CTR rank (PS2562-1, PS2562L-1 only)  
K: 2000 (%)  
L: 700 to 3400 (%)  
M: 200 to 1000 (%)

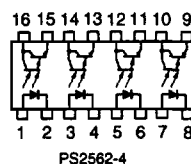
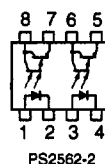

#### 2. Test Circuit for Switching Time

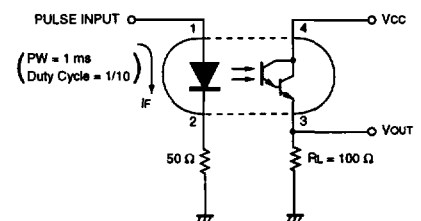

**PS2562- 1, -2, -4 PS2562L -1, -2, -4**

**ABSOLUTE MAXIMUM RATINGS<sup>1</sup> (TA = 25°C)**

SYMBOLS	PARAMETERS	UNITS	RATINGS	
			PS2562-1 PS2562L-1	PS2562-2,-4 PS2562L-2,-4
<b>Diode</b>				
VR	Reverse Voltage	V	6	6
IF	Forward Current	mA	80	80
Pd	Power Dissipation	mW/ch	150	120
IF (PEAK)	Peak Forward Current (PW = 100 μs, Duty Cycle 1%)	A	1	1
<b>Transistor</b>				
VCEO	Collector to Emitter Voltage	V	40	40
VECO	Emitter to Collector Voltage	V	6	6
IC	Collector Current	mA	200	160
Pc	Power Dissipation	mW/ch	200	160
<b>Coupled</b>				
BV	Isolation Voltage <sup>2</sup>	V <sub>r.m.s.</sub>	5000	5000
BV	Isolation Voltage <sup>2</sup>	V <sub>r.m.s.</sub>	3750	3750
PT	Total Power Dissipation	mW/ch	250	200
TSTG	Storage Temperature	°C	-55 to +150	-55 to +150
TOP	Operating Temperature	°C	-55 to +100	-55 to +100
TSOL	Lead Temperature (Soldering 10 s)	°C	260	260

**Notes:**

1. Operation in excess of any one of these parameters may result in permanent damage.
2. AC voltage for 1 minute at TA = 25 °C, RH = 60 % between input and output.

**TYPICAL PERFORMANCE CURVES (TA = 25 °C)**

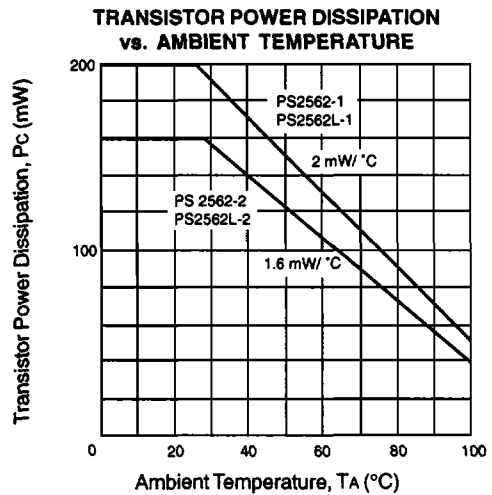
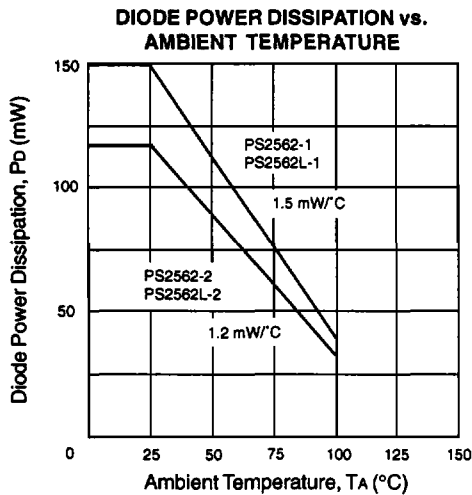
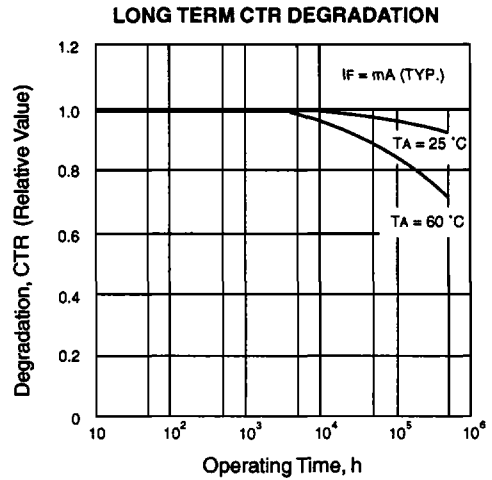

**TYPICAL PERFORMANCE CURVES** ( $T_A = 25^\circ\text{C}$ )

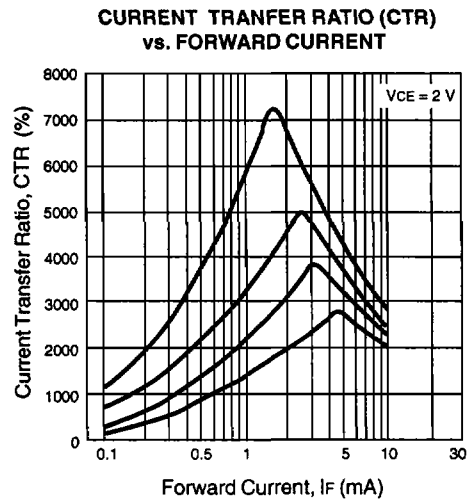
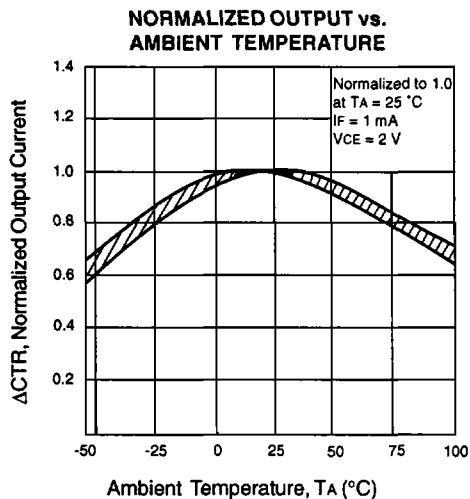
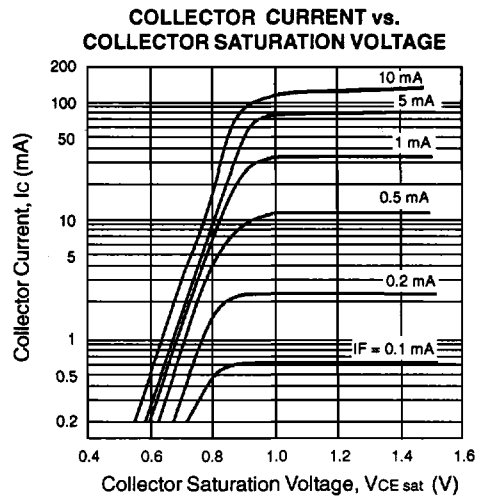
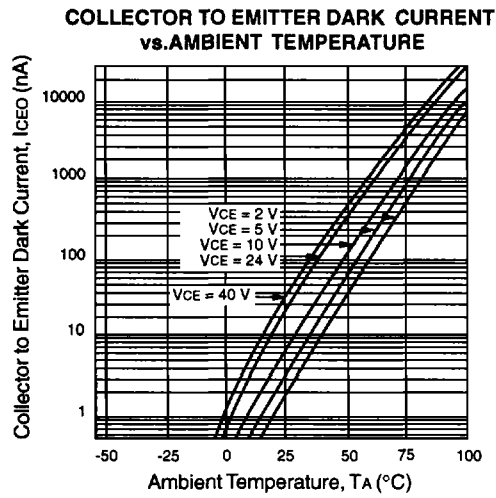
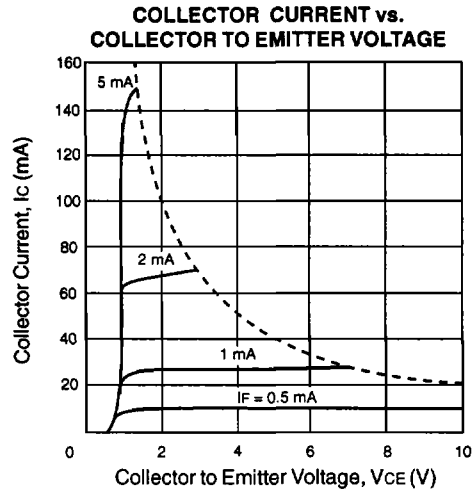
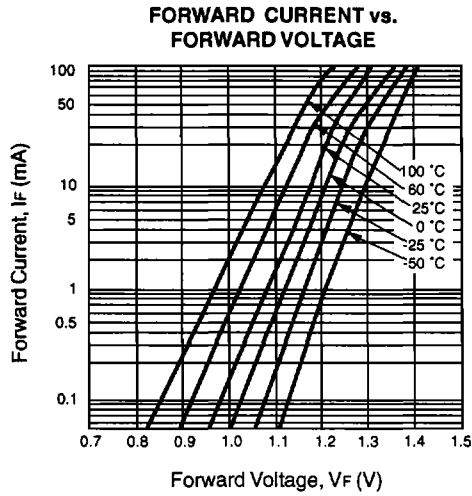

TYPICAL CHARACTERISTICS (T<sub>A</sub> = 25 °C)

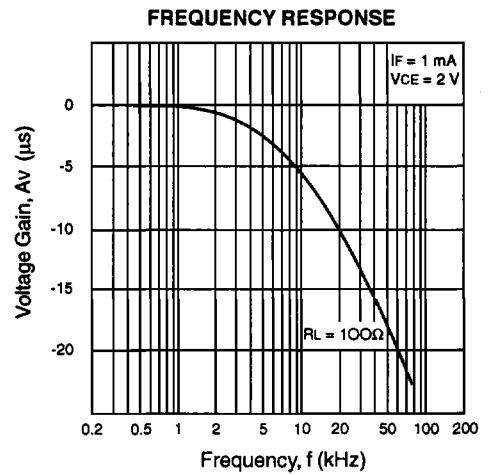
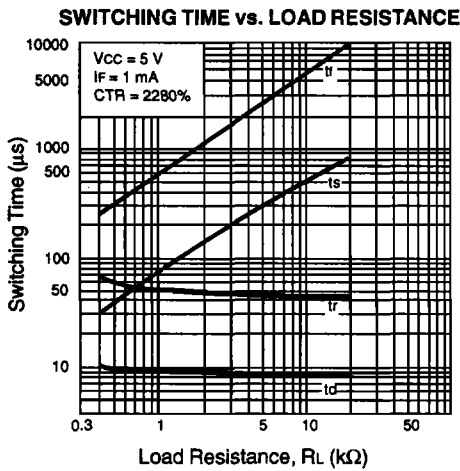
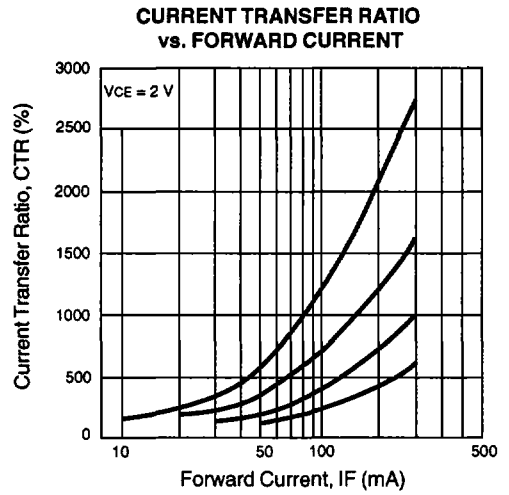
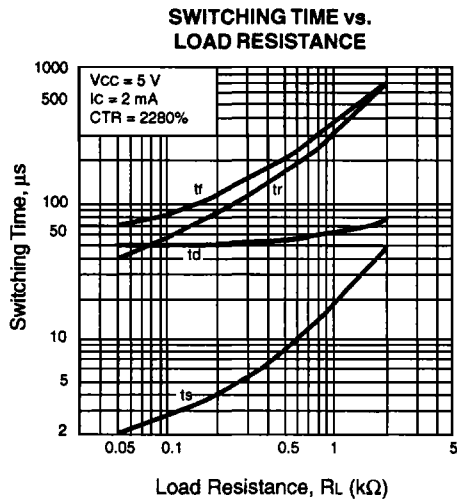

**OUTLINE DIMENSIONS** (Units in mm)

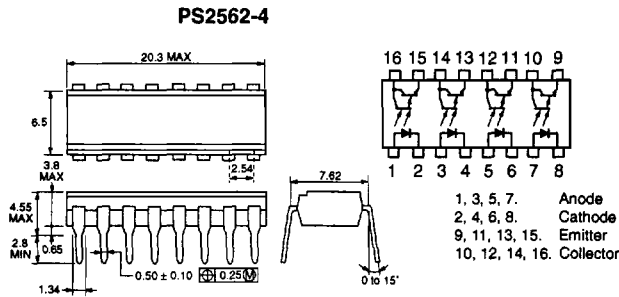
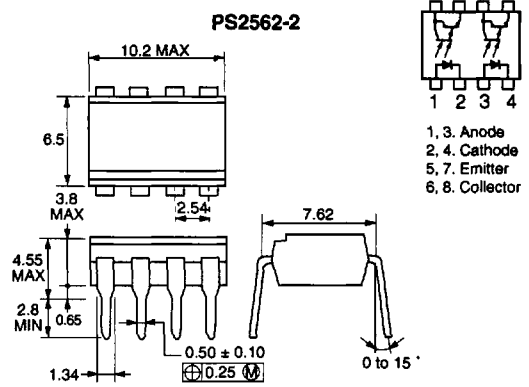
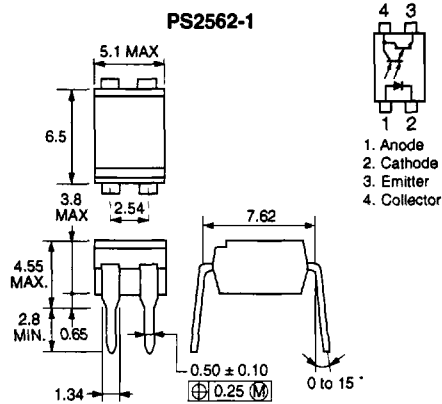

**OUTLINE DIMENSIONS** (Units in mm)

