

Silicon NPN High Voltage Switching Transistor

Features

- HIGH SPEED technology
- Glass passivation
- Very short switching times
- Very low switching losses
- Very low dynamic saturation
- Very low operating temperature
- High reverse voltage

Applications

Electronic lamp ballast circuits
Switch-mode power supplies

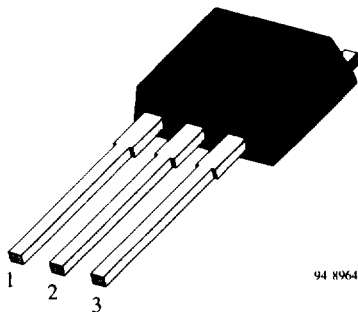

TD13002 • TD13003
1 Base 2 Collector 3 Emitter

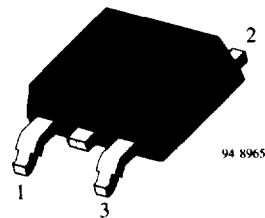

TD13002 • TD13003-SMD
1 Base 2 Collector 3 Emitter

Absolute Maximum Ratings

$T_{case} = 25^{\circ}C$, unless otherwise specified

Parameter	Test Conditions	Type	Symbol	Value	Unit
Collector-emitter voltage		TD13002	V_{CEO}	300	V
		TD13003	V_{CEO}	400	V
		TD13002	V_{CES}	600	V
		TD13003	V_{CES}	700	V
Emitter-base voltage			V_{EBO}	9	V
Collector current			I_C	1.5	A
Collector peak current			I_{CM}	3	A
Base current			I_B	0.75	A
			$-I_B$	0.75	A
Total power dissipation	$T_{case} \leq 60^{\circ}C$		P_{tot}	20	W
Junction temperature			T_j	150	$^{\circ}C$
Storage temperature range			T_{stg}	-65 to +150	$^{\circ}C$

Maximum Thermal Resistance

$T_{\text{case}} = 25^{\circ}\text{C}$, unless otherwise specified

Parameter	Test Conditions	Symbol	Value	Unit
Junction case		R_{thJC}	4.5	K/W

Electrical Characteristics

$T_{\text{case}} = 25^{\circ}\text{C}$, unless otherwise specified

Parameter	Test Conditions	Type	Symbol	Min	Typ	Max	Unit
Collector cut-off current	$V_{\text{CE}} = 600 \text{ V}$	TD13002	I_{CES}			0.1	mA
	$V_{\text{CE}} = 700 \text{ V}$	TD13003	I_{CES}			0.1	mA
	$V_{\text{CE}} = 600 \text{ V}; T_{\text{case}} = 150^{\circ}\text{C}$	TD13002	I_{CES}			1	mA
	$V_{\text{CE}} = 700 \text{ V}; T_{\text{case}} = 150^{\circ}\text{C}$	TD13003	I_{CES}			1	mA
Collector-emitter breakdown voltage (figure 1)	$I_{\text{C}} = 100 \text{ mA}; L = 500 \text{ mH}; I_{\text{measure}} = 50 \text{ mA}$	TD13002	$V_{(\text{BR})\text{CEO}}$	300			V
	$I_{\text{C}} = 100 \text{ mA}; L = 500 \text{ mH}; I_{\text{measure}} = 50 \text{ mA}$	TD13003	$V_{(\text{BR})\text{CEO}}$	400			V
Emitter-base breakdown voltage	$I_{\text{E}} = 1 \text{ mA}$		$V_{(\text{BR})\text{EBO}}$	9			V
Collector-emitter saturation voltage	$I_{\text{C}} = 100 \text{ mA}; I_{\text{B}} = 10 \text{ mA}$		V_{CEsat}			1.5	V
	$I_{\text{C}} = 1 \text{ A}; I_{\text{B}} = 0.25 \text{ A}$		V_{CEsat}			1	V
Base-emitter saturation voltage	$I_{\text{C}} = 1 \text{ A}; I_{\text{B}} = 0.25 \text{ A}$		V_{BEsat}			1.6	V
DC forward current transfer ratio	$V_{\text{CE}} = 2 \text{ V}; I_{\text{C}} = 0.5 \text{ A}$		h_{FE}	8		40	
	$V_{\text{CE}} = 2 \text{ V}; I_{\text{C}} = 1 \text{ A}$		h_{FE}	5		25	
Gain bandwidth product	$V_{\text{CE}} = 10 \text{ V}; I_{\text{C}} = 100 \text{ mA}; f = 1 \text{ MHz}$		f_{T}	4	10		MHz

Switching Characteristics

$T_{\text{case}} = 25^{\circ}\text{C}$, unless otherwise specified

Parameter	Test Conditions	Type	Symbol	Min	Typ	Max	Unit
Resistive load (figure 2)							
Turn on time	$I_{\text{C}} = 1 \text{ A}; I_{\text{B1}} = -I_{\text{B2}} = 0.2 \text{ A};$		t_{on}		0.2	0.4	μs
Storage time	$V_{\text{S}} = 125 \text{ V}$		t_{s}		1.7	2.5	μs
Fall time			t_{f}		0.2	0.3	μs
Inductive load (figure 3)							
Storage time	$I_{\text{C}} = 1 \text{ A}; I_{\text{B1}} = 0.2 \text{ A};$		t_{s}		1.2	2	μs
Cross over time	$L = 200 \mu\text{H}; V_{\text{clamp}} = 300 \text{ V}; -V_{\text{BE}} = 5 \text{ V}; T_{\text{case}} = 100^{\circ}\text{C}$		t_{c}		0.4	0.7	μs

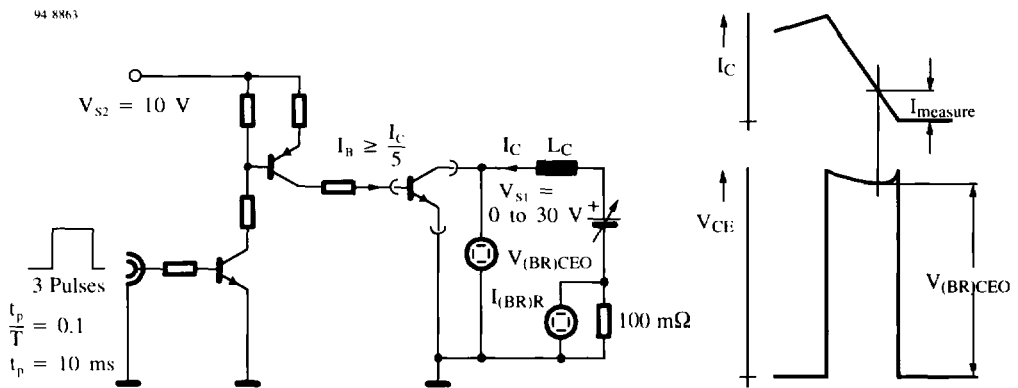

94 8852

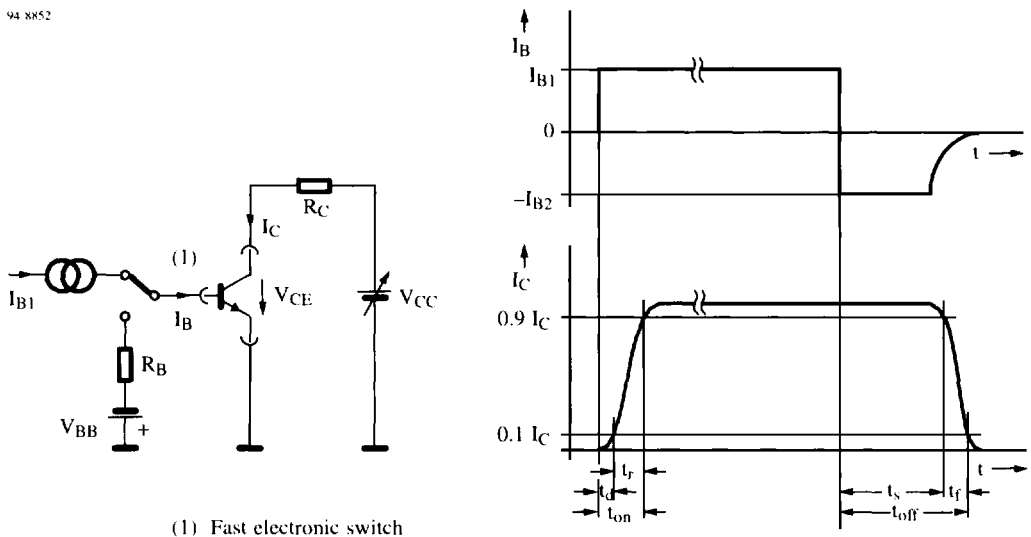

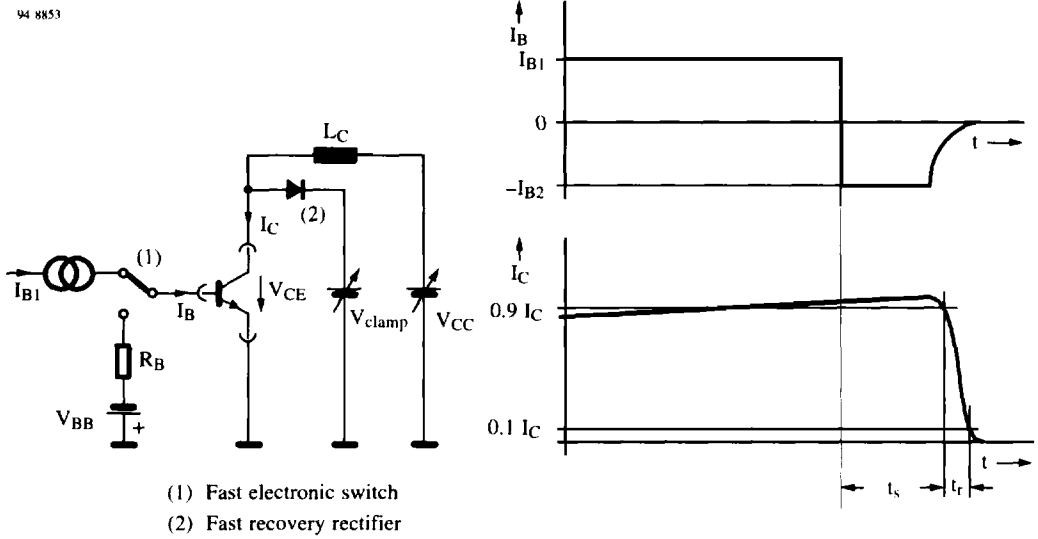

Figure 3. Test circuit for switching characteristics – inductive load

Typical Characteristics ($T_{case} = 25^{\circ}C$ unless otherwise specified)

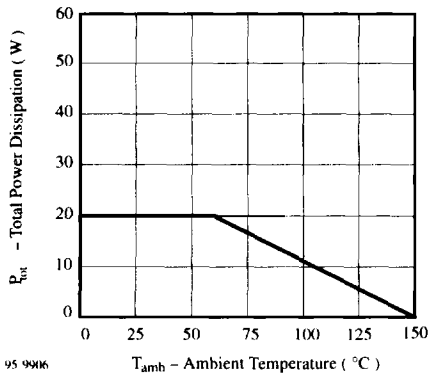

Figure 4. P_{tot} vs. T_{case}

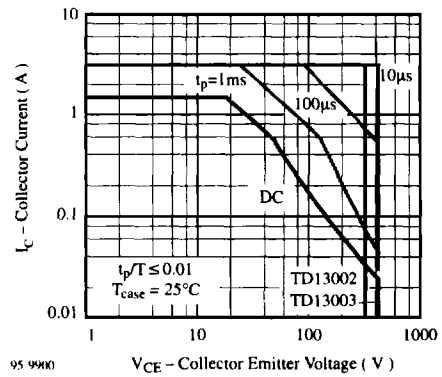

Figure 7. I_C vs. V_{CE}

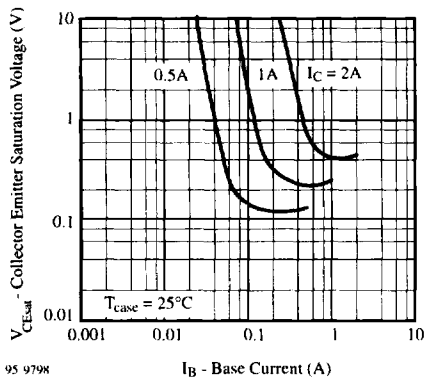

Figure 5. V_{CEsat} vs. I_B

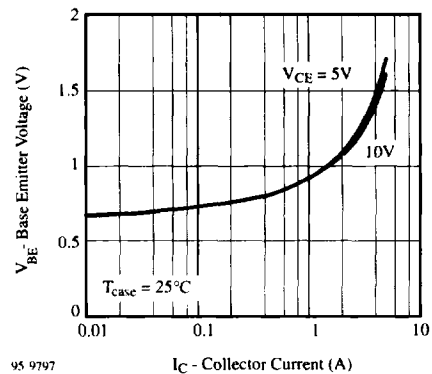

Figure 8. V_{BE} vs. I_C

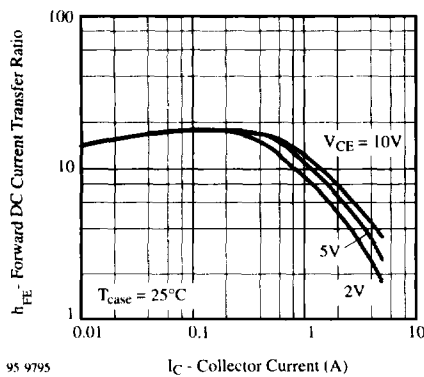

Figure 6. h_{FE} vs. I_C

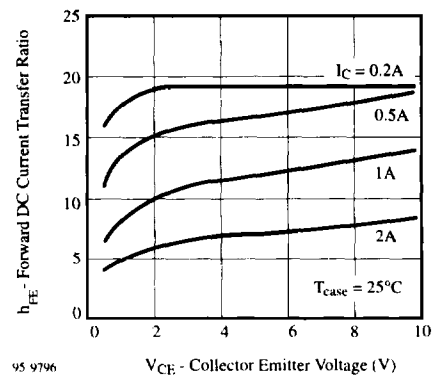

Figure 9. h_{FE} vs. V_{CE}

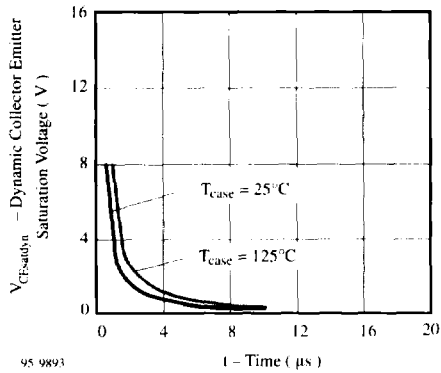

Figure 10. $V_{CEsatdyn}$ vs. t

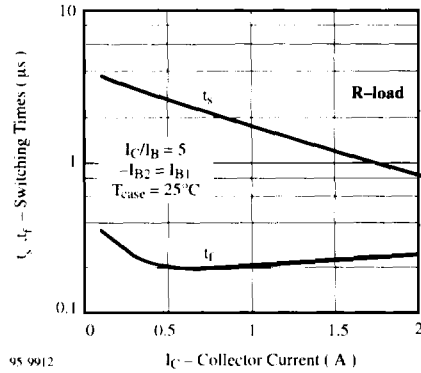

Figure 12. t_s, t_f vs. I_C

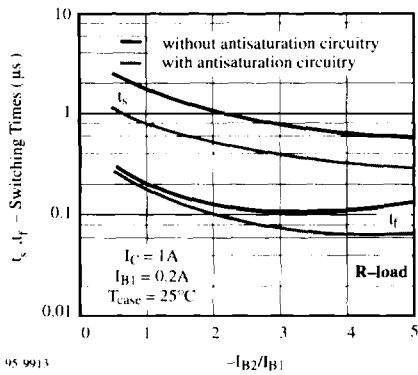

Figure 11. t_s, t_f vs. $-I_{B2}/I_{B1}$

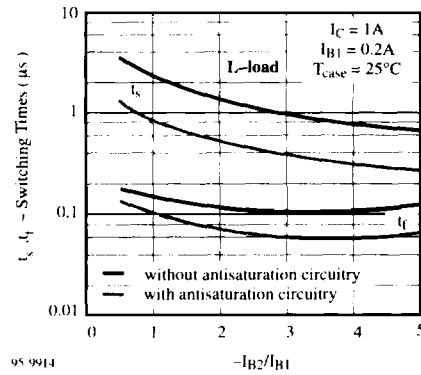
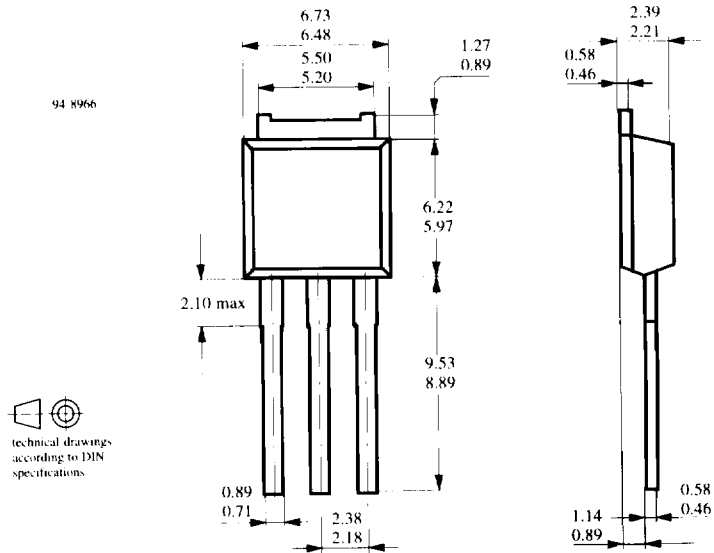

Figure 13. t_s, t_f vs. $-I_{B2}/I_{B1}$

Dimensions in mm

TO251



TO252

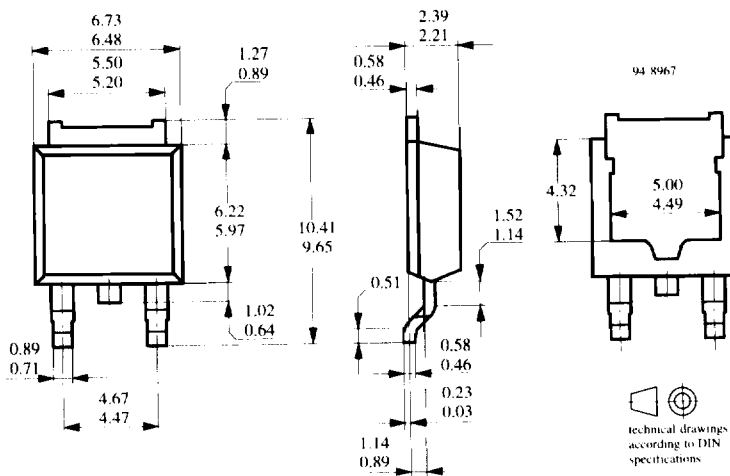

For ordering TO 252 add SMD to the type number (i.e. TD13003-SMD)