

**HiRel C-Band GaAs Power-MESFET**

- **HiRel Discrete and Microwave Semiconductor**
- For professional power amplifiers
- For frequencies from 100 MHz to 4.5 GHz
- Hermetically sealed microwave power package
- Low thermal resistance for high voltage application
- Power added efficiency > 53 %
-  **ESA Space Qualification Expected 1998**  
 ESA/SCC Detail Spec. No.: 5614/008,  
 Type Variant No.s 04 to 06

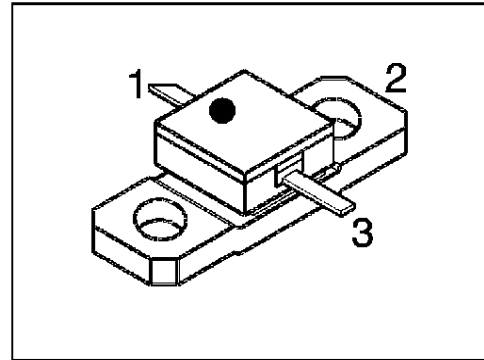

**ESD:** Electrostatic discharge sensitive device, observe handling precautions!

Type	Marking	Ordering Code	Pin Configuration			Package
			1	2	3	
CLY35-00 (ql)	-	see below	G	S	D	MWP-35
CLY35-05 (ql)						
CLY35-10 (ql)						

CLY35-nn: specifies output power level (see electrical characteristics)

(ql) Quality Level:	P: Professional Quality,	Ordering Code:	Q62702L113
	H: High Rel Quality,	Ordering Code:	on request
	S: Space Quality,	Ordering Code:	on request
	ES: ESA Space Quality,	Ordering Code:	Q62702L112

(see order instructions for ordering example)

## Maximum Ratings

Parameter	Symbol	Values	Unit
Drain-source voltage	$V_{DS}$	14	V
Drain-gate voltage	$V_{DG}$	16	V
Gate-source voltage	$V_{GS}$	- 6	V
Drain current	$I_D$	2.8	A
Gate forward current	$I_G$	16	mA
Compression Level Operation Range 1 <sup>1)</sup>	$P_C$	1.5 at $V_{DS} \leq 9\text{ V}$ 2.5 at $V_{DS} \leq 8\text{ V}$ 3.5 at $V_{DS} \leq 7\text{ V}$	dB
Compression Level Operation Range 2 <sup>2)</sup>	$P_C$	3.5 at $V_{DS} \leq 7\text{ V}$	dB
Compression Level Operation Range 3 <sup>3)</sup>	$P_C$	tbd.	dB
Junction temperature	$T_J$	175	°C
Storage temperature range	$T_{stg}$	- 65...+ 175	°C
Total power dissipation <sup>4)</sup>	$P_{tot}$	18	W
Soldering temperature <sup>5)</sup>	$T_{sol}$	230	°C

## Thermal Resistance

Junction-soldering point	$R_{th JS}$	$\leq 7.5$	K/W
--------------------------	-------------	------------	-----

**Notes.:**

- 1) Operation Range 1:  $480\text{ mA} \leq I_D \leq 960\text{ mA}$
- 2) Operation Range 2:  $I_D > 960\text{ mA}$
- 3) Operation Range 3:  $I_D < 480\text{ mA}$
- 4) At  $T_s = + 40\text{ °C}$ . For  $T_s > + 40\text{ °C}$  derating is required.
- 5) During 15 sec. maximum. The same terminal shall not be resoldered until 3 minutes have elapsed.

**Electrical Characteristics** (at  $T_A=25^\circ\text{C}$ ; unless otherwise specified)

Parameter	Symbol	Values			Unit
		min.	typ.	max.	
<b>DC Characteristics</b>					
Drain-source saturation current $V_{DS} = 2\text{ V}, V_{GS} = 0\text{ V}$	$I_{Dss}$	1.2	2.0	2.8	A
Gate threshold voltage $V_{DS} = 3\text{ V}, I_D = 80\text{ mA}$	$-V_{Gth}$	1.6	2.6	3.6	V
Drain current at pinch-off, low $V_{DS}$ $V_{DS} = 3\text{ V}, V_{GS} = -3.8\text{ V}$	$I_{Dp3}$	-	-	200	$\mu\text{A}$
Gate current at pinch-off, low $V_{DS}$ $V_{DS} = 3\text{ V}, V_{GS} = -3.8\text{ V}$	$-I_{Gp3}$	-	-	80	$\mu\text{A}$
Drain current at pinch-off, high $V_{DS}$ $V_{DS} = 12\text{ V}, V_{GS} = -4\text{ V}$	$I_{Dp12}$	-	-	4000	$\mu\text{A}$
Gate current at pinch-off, high $V_{DS}$ $V_{DS} = 12\text{ V}, V_{GS} = -4\text{ V}$	$-I_{Gp12}$	-	-	1600	$\mu\text{A}$
Transconductance $V_{DS} = 3\text{ V}, I_D = 720\text{ mA}$	$g_m$	600	730	-	mS
Thermal resistance junction to soldering point $V_{DS} = 9\text{ V}, I_D = 720\text{ mA}, T_s = +25^\circ\text{C}$	$R_{thJS}$	-	6.8	-	K/W

**Electrical Characteristics** (continued)

Parameter	Symbol	Values			Unit
		min.	typ.	max.	
<b>AC Characteristics</b>					
Linear power gain <sup>1)</sup> $V_{DS} = 9\text{ V}$ , $I_D = 720\text{ mA}$ , $f = 2.3\text{ GHz}$ , $P_{in} = 0\text{ dBm}$	$G_{ip}$				dB
CLY35-00		10.0	11.0	-	
CLY35-05		10.5	11.2	-	
CLY35-10		10.5	11.2	-	
Output power at 1dB gain compr. <sup>1)</sup> $V_{DS} = 9\text{ V}$ , $I_{D(RF\ off)} = 720\text{ mA}$ , $f = 2.3\text{ GHz}$	$P_{1dB}$				dBm
CLY35-00		34.5	34.8	-	
CLY35-05		35	35.3	-	
CLY35-10		35.5	35.8	-	
Output power <sup>1)</sup> $V_{DS} = 9\text{ V}$ , $I_{D(RF\ off)} = 720\text{ mA}$ , $f = 2.3\text{ GHz}$ , $P_{in} = 25\text{ dBm}$	$P_{out}$				dBm
CLY35-00		-	34.8	-	
CLY35-05		-	35.3	-	
CLY35-10		-	35.8	-	
Power added efficiency <sup>1), 2)</sup> $V_{DS} = 9\text{ V}$ , $I_{D(RF\ off)} = 720\text{ mA}$ , $f = 2.3\text{ GHz}$ , @ 1dB gain compression	PAE				%
CLY35-00		40	47	-	
CLY35-05		45	50	-	
CLY35-10		45	53	-	

**Notes.:**

1) RF Power characteristics given for power matching conditions

2) Power added efficiency:  $PAE = (P_{RFout} - P_{RFin}) / P_{DC}$

**Typical Common Source S-Parameters**

$V_{GS} = 3\text{ V}, I_D = 720\text{ mA}, Z_0 = 50\ \Omega$											
f	S11	<S11	S21	<S21	S12	<S12	S22	<S22	k-Fact.	$S_{21}/S_{12}$	MAG
[GHz]	[magn]	[angle]	[magn]	[angle]	[magn]	[angle]	[magn]	[angle]	[magn]	[dB]	[dB]
0,5	0,895	-158	3,503	91	0,0227	15	0,812	171	0,50	21,9	
0,6	0,889	-162	3,274	89	0,0230	14	0,813	170	0,57	21,5	
0,7	0,883	-166	3,025	86	0,0233	12	0,815	168	0,64	21,1	
0,8	0,880	-171	2,762	83	0,0235	11	0,817	167	0,71	20,7	
0,9	0,882	-176	2,488	79	0,0239	9	0,819	165	0,76	20,2	
1,0	0,889	179	2,212	75	0,0242	7	0,822	163	0,79	19,6	
1,1	0,893	174	1,987	70	0,0244	6	0,823	161	0,84	19,1	
1,2	0,897	169	1,801	66	0,0245	4	0,824	159	0,89	18,7	
1,3	0,900	165	1,646	62	0,0247	3	0,824	157	0,93	18,2	
1,4	0,902	162	1,514	59	0,0250	1	0,824	155	0,98	17,8	
1,5	0,903	158	1,402	55	0,0255	0	0,824	153	1,03	17,4	16,3
1,6	0,904	155	1,305	52	0,0257	-1	0,823	151	1,08	17,1	15,3
1,7	0,905	152	1,220	49	0,0261	-2	0,823	150	1,13	16,7	14,5
1,8	0,904	149	1,145	46	0,0261	-3	0,825	148	1,19	16,4	13,8
1,9	0,903	146	1,079	43	0,0261	-4	0,826	147	1,26	16,2	13,1
2,0	0,902	143	1,020	40	0,0263	-5	0,828	146	1,31	15,9	12,5
2,1	0,901	141	0,965	37	0,0265	-6	0,830	144	1,37	15,6	12,0
2,2	0,900	138	0,914	35	0,0267	-7	0,832	143	1,43	15,3	11,5
2,3	0,899	136	0,869	32	0,0268	-8	0,834	142	1,48	15,1	11,0
2,4	0,898	134	0,827	29	0,0267	-9	0,835	140	1,55	14,9	10,6
2,5	0,897	131	0,789	27	0,0268	-9	0,837	139	1,61	14,7	10,1
2,6	0,897	129	0,755	24	0,0265	-10	0,838	137	1,70	14,5	9,7
2,7	0,896	127	0,723	21	0,0268	-10	0,839	136	1,76	14,3	9,3
2,8	0,895	125	0,695	19	0,0274	-11	0,840	134	1,79	14,0	8,9
2,9	0,894	123	0,670	16	0,0275	-11	0,840	133	1,85	13,9	8,5
3,0	0,893	121	0,648	14	0,0279	-12	0,842	132	1,88	13,7	8,2
3,1	0,893	119	0,626	12	0,0279	-12	0,844	131	1,93	13,5	8,0
3,2	0,892	117	0,606	10	0,0281	-13	0,845	130	1,98	13,3	7,7
3,3	0,890	116	0,586	7	0,0281	-14	0,847	129	2,04	13,2	7,4
3,4	0,890	114	0,568	5	0,0286	-15	0,848	128	2,06	13,0	7,1
3,5	0,888	112	0,550	3	0,0289	-15	0,850	127	2,11	12,8	6,8
3,6	0,887	110	0,534	1	0,0292	-17	0,851	125	2,14	12,6	6,6
3,7	0,886	108	0,519	-2	0,0293	-17	0,852	124	2,19	12,5	6,3
3,8	0,885	107	0,505	-4	0,0296	-18	0,854	123	2,22	12,3	6,1
3,9	0,883	105	0,492	-6	0,0299	-20	0,855	122	2,26	12,2	5,8
4,0	0,880	103	0,481	-8	0,0303	-21	0,856	121	2,31	12,0	5,6
4,1	0,879	101	0,470	-10	0,0306	-22	0,857	120	2,34	11,9	5,4
4,2	0,876	100	0,461	-12	0,0312	-22	0,859	119	2,35	11,7	5,2
4,3	0,873	98	0,451	-14	0,0312	-23	0,860	118	2,42	11,6	4,9
4,4	0,871	96	0,442	-16	0,0318	-24	0,860	117	2,46	11,4	4,7
4,5	0,867	95	0,434	-18	0,0322	-25	0,860	116	2,53	11,3	4,4
4,6	0,864	93	0,425	-20	0,0327	-26	0,859	115	2,62	11,1	4,1
4,7	0,861	92	0,418	-22	0,0333	-26	0,857	114	2,68	11,0	3,9
4,8	0,860	90	0,413	-23	0,0337	-27	0,855	113	2,76	10,9	3,6
4,9	0,858	89	0,408	-24	0,0342	-27	0,853	112	2,80	10,8	3,4
5,0	0,857	88	0,404	-25	0,0346	-27	0,851	111	2,87	10,7	3,2

Typical Common Source S-Parameters (continued)

$V_{GS} = 5\text{ V}, I_D = 720\text{ mA}, Z_0 = 50\ \Omega$											
f	S11	<S11	S21	<S21	S12	<S12	S22	<S22	k-Fact.	$S_{21}/S_{12}$	MAG
[GHz]	[mag]	[ang]	[mag]	[ang]	[mag]	[ang]	[mag]	[ang]	[mag]	[dB]	[dB]
0,5	0,886	-158	4,631	89	0,0216	14	0,734	173	0,53	23,3	
0,6	0,879	-161	4,325	87	0,0216	13	0,736	172	0,60	23,0	
0,7	0,873	-166	3,992	85	0,0217	12	0,739	170	0,68	22,6	
0,8	0,870	-170	3,640	81	0,0217	10	0,742	169	0,77	22,2	
0,9	0,872	-175	3,277	77	0,0217	9	0,746	167	0,84	21,8	
1,0	0,879	179	2,911	72	0,0220	7	0,750	165	0,87	21,2	
1,1	0,883	174	2,612	68	0,0221	5	0,753	163	0,91	20,7	
1,2	0,887	170	2,366	63	0,0222	3	0,755	161	0,96	20,3	
1,3	0,890	166	2,160	59	0,0226	2	0,757	159	1,00	19,8	19,5
1,4	0,892	162	1,984	56	0,0228	1	0,758	157	1,06	19,4	17,9
1,5	0,893	159	1,835	52	0,0231	-1	0,759	156	1,11	19,0	17,0
1,6	0,895	155	1,705	48	0,0230	-2	0,759	154	1,18	18,7	16,2
1,7	0,895	152	1,591	45	0,0235	-3	0,761	152	1,23	18,3	15,4
1,8	0,895	149	1,491	41	0,0238	-4	0,763	151	1,28	18,0	14,8
1,9	0,894	146	1,402	38	0,0239	-4	0,766	150	1,35	17,7	14,1
2,0	0,893	144	1,322	35	0,0238	-5	0,770	148	1,43	17,4	13,6
2,1	0,892	141	1,249	32	0,0241	-5	0,773	147	1,48	17,1	13,0
2,2	0,891	139	1,181	29	0,0240	-5	0,777	146	1,56	16,9	12,5
2,3	0,891	136	1,120	26	0,0240	-6	0,781	144	1,63	16,7	12,0
2,4	0,890	134	1,063	23	0,0239	-6	0,784	143	1,71	16,5	11,6
2,5	0,890	132	1,012	20	0,0240	-6	0,788	141	1,77	16,2	11,2
2,6	0,890	130	0,965	18	0,0239	-7	0,790	140	1,84	16,1	10,8
2,7	0,889	128	0,922	15	0,0237	-8	0,793	139	1,93	15,9	10,4
2,8	0,888	126	0,883	12	0,0241	-9	0,794	137	1,97	15,6	10,0
2,9	0,888	124	0,849	9	0,0244	-9	0,797	136	2,01	15,4	9,7
3,0	0,887	122	0,817	7	0,0243	-10	0,799	135	2,07	15,3	9,4
3,1	0,886	120	0,786	4	0,0244	-11	0,802	134	2,13	15,1	9,1
3,2	0,885	118	0,758	2	0,0248	-12	0,805	133	2,15	14,9	8,8
3,3	0,884	116	0,731	-1	0,0248	-13	0,808	132	2,20	14,7	8,5
3,4	0,883	114	0,705	-3	0,0251	-14	0,810	131	2,24	14,5	8,2
3,5	0,882	112	0,681	-6	0,0252	-14	0,814	130	2,30	14,3	7,9
3,6	0,881	111	0,658	-8	0,0255	-15	0,816	129	2,33	14,1	7,6
3,7	0,880	109	0,637	-11	0,0256	-16	0,819	127	2,38	14,0	7,4
3,8	0,879	107	0,617	-13	0,0255	-17	0,822	126	2,45	13,8	7,1
3,9	0,876	105	0,600	-16	0,0258	-17	0,825	125	2,49	13,7	6,9
4,0	0,874	104	0,584	-18	0,0264	-18	0,827	124	2,51	13,4	6,6
4,1	0,872	102	0,568	-20	0,0266	-19	0,830	123	2,55	13,3	6,4
4,2	0,870	100	0,554	-22	0,0269	-19	0,833	122	2,58	13,1	6,2
4,3	0,867	99	0,541	-25	0,0273	-20	0,836	121	2,61	13,0	6,0
4,4	0,865	97	0,528	-27	0,0277	-22	0,838	120	2,65	12,8	5,7
4,5	0,861	95	0,515	-29	0,0284	-23	0,839	119	2,69	12,6	5,4
4,6	0,858	94	0,503	-31	0,0287	-23	0,838	118	2,78	12,4	5,1
4,7	0,856	92	0,493	-33	0,0293	-23	0,837	117	2,85	12,3	4,8
4,8	0,854	91	0,484	-34	0,0296	-24	0,835	116	2,93	12,1	4,6
4,9	0,853	90	0,477	-36	0,0298	-24	0,834	115	2,99	12,0	4,4
5,0	0,852	89	0,471	-37	0,0299	-25	0,831	114	3,08	12,0	4,2

**Typical Common Source S-Parameters** (continued)

$V_{GS} = 9\text{ V}, I_D = 720\text{ mA}, Z_0 = 50\ \Omega$											
f	S11	<S11	S21	<S21	S12	<S12	S22	<S22	k-Fact.	$S_{21}/S_{12}$	MAG
[GHz]	[mag]	[ang]	[mag]	[ang]	[mag]	[ang]	[mag]	[ang]	[mag]	[dB]	[dB]
0,5	0,878	-157	5,845	87	0,0195	13	0,599	177	0,61	24,8	
0,6	0,872	-160	5,453	85	0,0196	13	0,603	176	0,69	24,4	
0,7	0,866	-165	5,026	82	0,0197	11	0,608	175	0,77	24,1	
0,8	0,864	-169	4,576	78	0,0197	10	0,614	174	0,86	23,7	
0,9	0,866	-174	4,112	74	0,0197	8	0,620	172	0,93	23,2	
1,0	0,874	-180	3,650	68	0,0195	6	0,628	171	0,98	22,7	
1,1	0,878	175	3,269	63	0,0195	5	0,635	169	1,04	22,2	21,0
1,2	0,882	171	2,954	58	0,0196	3	0,641	167	1,10	21,8	19,9
1,3	0,885	167	2,690	54	0,0194	2	0,647	165	1,17	21,4	18,9
1,4	0,888	163	2,465	49	0,0195	1	0,652	164	1,23	21,0	18,1
1,5	0,889	159	2,272	45	0,0195	-1	0,657	162	1,29	20,7	17,4
1,6	0,891	156	2,104	41	0,0196	-1	0,662	160	1,36	20,3	16,7
1,7	0,891	153	1,957	37	0,0196	-2	0,668	159	1,43	20,0	16,1
1,8	0,891	150	1,826	33	0,0195	-3	0,675	158	1,52	19,7	15,5
1,9	0,890	147	1,709	30	0,0195	-3	0,682	157	1,60	19,4	14,9
2,0	0,890	145	1,604	26	0,0196	-4	0,690	155	1,67	19,1	14,3
2,1	0,889	142	1,507	23	0,0195	-4	0,698	154	1,77	18,9	13,8
2,2	0,889	140	1,419	19	0,0195	-4	0,706	153	1,84	18,6	13,3
2,3	0,888	137	1,337	16	0,0190	-4	0,714	151	1,98	18,5	12,8
2,4	0,888	135	1,263	13	0,0188	-4	0,722	150	2,08	18,3	12,4
2,5	0,888	133	1,196	10	0,0186	-4	0,729	148	2,18	18,1	11,9
2,6	0,888	131	1,134	6	0,0186	-3	0,735	147	2,26	17,9	11,5
2,7	0,888	129	1,078	3	0,0188	-4	0,741	145	2,31	17,6	11,2
2,8	0,888	127	1,028	0	0,0191	-3	0,747	144	2,37	17,3	10,8
2,9	0,888	125	0,982	-3	0,0194	-2	0,752	143	2,40	17,0	10,4
3,0	0,887	123	0,939	-6	0,0198	-3	0,759	142	2,41	16,8	10,1
3,1	0,887	121	0,899	-9	0,0202	-3	0,765	141	2,41	16,5	9,8
3,2	0,886	119	0,862	-11	0,0205	-4	0,771	140	2,44	16,2	9,5
3,3	0,885	117	0,826	-14	0,0210	-4	0,777	138	2,44	15,9	9,2
3,4	0,885	115	0,791	-17	0,0213	-4	0,783	137	2,47	15,7	9,0
3,5	0,883	113	0,759	-19	0,0215	-4	0,790	136	2,51	15,5	8,6
3,6	0,882	111	0,729	-22	0,0218	-5	0,795	135	2,54	15,2	8,4
3,7	0,882	109	0,701	-25	0,0218	-5	0,801	133	2,58	15,1	8,1
3,8	0,881	108	0,675	-27	0,0218	-6	0,806	132	2,64	14,9	7,8
3,9	0,879	106	0,651	-30	0,0219	-6	0,811	131	2,71	14,7	7,5
4,0	0,877	104	0,629	-33	0,0221	-6	0,816	130	2,76	14,5	7,3
4,1	0,875	102	0,609	-35	0,0226	-7	0,821	128	2,75	14,3	7,1
4,2	0,873	101	0,590	-37	0,0226	-7	0,826	127	2,81	14,2	6,8
4,3	0,870	99	0,572	-40	0,0230	-8	0,831	126	2,84	14,0	6,5
4,4	0,867	97	0,554	-42	0,0234	-9	0,834	125	2,89	13,7	6,3
4,5	0,863	96	0,537	-44	0,0236	-10	0,837	124	2,98	13,6	5,9
4,6	0,860	94	0,520	-46	0,0244	-11	0,838	123	3,02	13,3	5,6
4,7	0,858	93	0,506	-48	0,0249	-11	0,839	122	3,07	13,1	5,3
4,8	0,856	91	0,495	-50	0,0256	-12	0,839	121	3,09	12,9	5,1
4,9	0,855	90	0,485	-51	0,0260	-12	0,838	120	3,14	12,7	4,8
5,0	0,853	89	0,477	-53	0,0266	-13	0,837	119	3,18	12,5	4,6

**Order Instructions:**

Full type variant including quality level must be specified by the orderer. For *HiRel* Discrete and Microwave Semiconductors the ordering code specifies device family and quality level only.

## Ordering Form:

Ordering Code: Q.....  
CLY35- (nn) (ql)  
(nn): Output Power Level  
(ql): Quality Level

## Ordering Example:

Ordering Code: Q62702L112  
CLY35-10 ES  
For CLY35; Output Power Level 10 ( $P_{1dB} > 35.5$  dBm)  
in ESA Space Quality Level

**Further Informations:**

See our WWW-Pages:

- Discrete and RF-Semiconductors (Small Signal Semiconductors)

[www.siemens.de/semiconductor/products/35/35.htm](http://www.siemens.de/semiconductor/products/35/35.htm)

- *HiRel* Discrete and Microwave Semiconductors

[www.siemens.de/semiconductor/products/35/353.htm](http://www.siemens.de/semiconductor/products/35/353.htm)

Please contact also our marketing division :

Tel.: ++89 6362 4480  
Fax.: ++89 6362 5568  
e-mail: [martin.wimmers@siemens-scg.com](mailto:martin.wimmers@siemens-scg.com)  
Address: Siemens Semiconductors,  
High Frequency Products Marketing,  
P.O.Box 801709,  
D-81617 Munich

MWP-35 Package

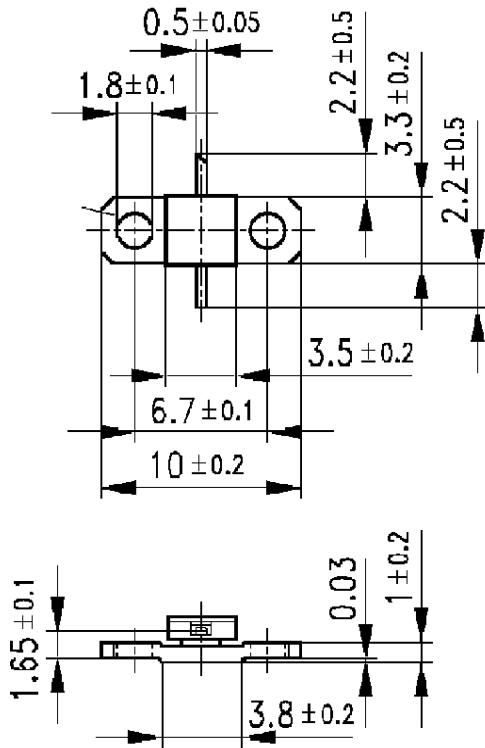

Published by Siemens Semiconductors, High Frequency Products Marketing, P.O.Box 801709, D-81617 Munich.

© Siemens AG 1998. All Rights Reserved.

As far as patents or other rights of third parties are concerned, liability is only assumed for components per se, not for applications, processes and circuits implemented within components or assemblies.

The information describes the type of component and shall not be considered as assured characteristics.

Terms of delivery and rights to change design reserved.

For questions on technology, delivery and prices please contact the Offices of Semiconductor Group in Germany or the Siemens Companies and Representatives worldwide (see address list).

Due to technical requirements components may contain dangerous substances. For information on the type in question please contact your nearest Siemens Office, Semiconductor Group.

Siemens Semiconductors is a certified CECC and QS9000 manufacturer (this includes ISO 9000).