

# Quad 2-Input Register

**Features**

- Function, pinout and drive compatible with FCT and F logic
- FCT-C speed at 6.1 ns max. (Com'l)  
FCT-A speed at 7.0 ns max. (Com'l)
- Reduced  $V_{OH}$  (typically = 3.3V) versions of equivalent FCT functions
- Edge-rate control circuitry for significantly improved noise characteristics
- Power-off disable feature
- Matched rise and fall times

- ESD > 2000V
- Fully compatible with TTL input and output logic levels
- Sink current      **64 mA (Com'l),  
32 mA (Mil)**
- Source current   **32 mA (Com'l),  
12 mA (Mil)**

**Functional Description**

The FCT399T is a high-speed quad dual-port register that selects four bits of data from either of two sources (Ports) under control of a common Select input

(S). The selected data is transferred to a 4-bit output register synchronous with the LOW-to-HIGH transition of the Clock input (CP). The 4-bit D-type output register is fully edge-triggered. The Data inputs ( $I_{0X}$ ,  $I_{1X}$ ) and Select input (S) must be stable only one set-up time prior to, and hold time after, the LOW-to-HIGH transition of the Clock input for predictable operation. The FCT399T offers true outputs.

The outputs are designed with a power-off disable feature to allow for live insertion of boards.

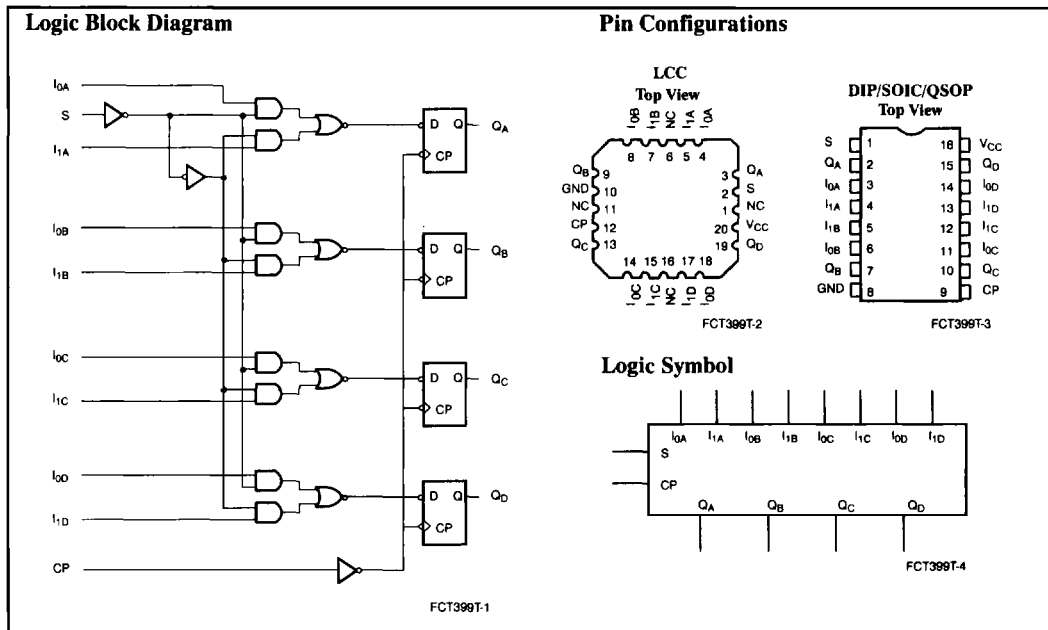
**Pin Description**

Name	Description
S	Common Select Input
CP	Clock Pulse Input (Active Rising Edge)
$I_0$	Data Inputs from Source 0
$I_1$	Data Inputs from Source 1
Q	Register True Outputs

**Function Table<sup>[1]</sup>**

Inputs			Outputs
S	$I_0$	$I_1$	Q
l	l	X	L
l	h	X	H
h	X	l	L
h	X	h	H

**Note:**

1. H = HIGH Voltage Level  
h = HIGH Voltage Level one set-up time prior to the LOW-to-HIGH Clock Transition  
L = LOW Voltage Level  
l = LOW Voltage Level one set-up time prior to the LOW-to-HIGH Clock Transition  
X = Don't Care

**Maximum Ratings**<sup>[2, 3]</sup>

(Above which the useful life may be impaired. For user guidelines, not tested.)

Storage Temperature	-65°C to +150°C
Ambient Temperature with Power Applied	-65°C to +135°C
Supply Voltage to Ground Potential	-0.5V to +7.0V
DC Input Voltage	-0.5V to +7.0V
DC Output Voltage	-0.5V to +7.0V
DC Output Current (Maximum Sink Current/Pin)	120 mA
Power Dissipation	0.5W

 Static Discharge Voltage ..... >2001V  
 (per MIL-STD-883, Method 3015)

**Operating Range**

Range	Range	Ambient Temperature	V <sub>CC</sub>
Commercial	CT	0°C to +70°C	5V ± 5%
Commercial	T, AT	-40°C to +85°C	5V ± 5%
Military <sup>[4]</sup>	All	-55°C to +125°C	5V ± 10%

**Electrical Characteristics Over the Operating Range**

Parameter	Description	Test Conditions	Min.	Typ. <sup>[5]</sup>	Max.	Unit	
V <sub>OH</sub>	Output HIGH Voltage	V <sub>CC</sub> =Min., I <sub>OH</sub> =-32 mA	Com'l	2.0		V	
		V <sub>CC</sub> =Min., I <sub>OH</sub> =-15 mA	Com'l	2.4	3.3	V	
		V <sub>CC</sub> =Min., I <sub>OH</sub> =-12 mA	Mil	2.4	3.3	V	
V <sub>OL</sub>	Output LOW Voltage	V <sub>CC</sub> =Min., I <sub>OL</sub> =64 mA	Com'l		0.3	0.55	V
		V <sub>CC</sub> =Min., I <sub>OL</sub> =32 mA	Mil		0.3	0.55	V
V <sub>IH</sub>	Input HIGH Voltage		2.0			V	
V <sub>IL</sub>	Input LOW Voltage				0.8	V	
V <sub>H</sub>	Hysteresis <sup>[6]</sup>	All inputs		0.2		V	
V <sub>IK</sub>	Input Clamp Diode Voltage	V <sub>CC</sub> =Min., I <sub>IN</sub> =-18 mA		-0.7	-1.2	V	
I <sub>I</sub>	Input HIGH Current	V <sub>CC</sub> =Max., V <sub>IN</sub> =V <sub>CC</sub>			5	μA	
I <sub>IH</sub>	Input HIGH Current	V <sub>CC</sub> =Max., V <sub>IN</sub> =2.7V			±1	μA	
I <sub>IL</sub>	Input LOW Current	V <sub>CC</sub> =Max., V <sub>IN</sub> =0.5V			±1	μA	
I <sub>OS</sub>	Output Short Circuit Current <sup>[7]</sup>	V <sub>CC</sub> =Max., V <sub>OUT</sub> =0.0V	-60	-120	-225	mA	
I <sub>OFF</sub>	Power-Off Disable	V <sub>CC</sub> =0V, V <sub>OUT</sub> =4.5V			±1	μA	

**Capacitance**<sup>[6]</sup>

Parameter	Description	Typ. <sup>[5]</sup>	Max.	Unit
C <sub>IN</sub>	Input Capacitance	5	10	pF
C <sub>OUT</sub>	Output Capacitance	9	12	pF

**Notes:**

- Unless otherwise noted, these limits are over the operating free-air temperature range.
- Unused inputs must always be connected to an appropriate logic voltage level, preferably either V<sub>CC</sub> or ground.
- T<sub>A</sub> is the "instant on" case temperature.
- Typical values are at V<sub>CC</sub>=5.0V, T<sub>A</sub>=+25°C ambient.
- This parameter is guaranteed but not tested.
- Not more than one output should be shorted at a time. Duration of short should not exceed one second. The use of high-speed test apparatus and/or sample and hold techniques is preferable in order to minimize internal chip heating and more accurately reflect operational values. Otherwise prolonged shorting of a high output may raise the chip temperature well above normal and thereby cause invalid readings in other parametric tests. In any sequence of parameter tests, I<sub>OS</sub> tests should be performed last.

**Power Supply Characteristics**

Parameter	Description	Test Conditions	Typ. <sup>[5]</sup>	Max.	Unit
I <sub>CC</sub>	Quiescent Power Supply Current	V <sub>CC</sub> =Max., V <sub>IN</sub> ≤0.2V, V <sub>IN</sub> ≥V <sub>CC</sub> -0.2V	0.1	0.2	mA
ΔI <sub>CC</sub>	Quiescent Power Supply Current (TTL inputs)	V <sub>CC</sub> =Max., V <sub>IN</sub> =3.4V <sup>[8]</sup> f <sub>1</sub> =0, Outputs Open	0.5	2.0	mA
I <sub>CCD</sub>	Dynamic Power Supply Current <sup>[9]</sup>	V <sub>CC</sub> =Max., One Input Toggling, 50% Duty Cycle, Outputs Open, V <sub>IN</sub> ≤0.2V or V <sub>IN</sub> ≥V <sub>CC</sub> -0.2V	0.06	0.12	mA/ MHz
I <sub>C</sub>	Total Power Supply Current <sup>[10]</sup>	V <sub>CC</sub> =Max., f <sub>0</sub> =10 MHz, 50% Duty Cycle, Outputs Open, One Input Toggling at f <sub>1</sub> =5 MHz, S=Steady State V <sub>IN</sub> ≤0.2V or V <sub>IN</sub> ≥V <sub>CC</sub> -0.2V	0.7	1.4	mA
		V <sub>CC</sub> =Max., f <sub>0</sub> =10 MHz, 50% Duty Cycle, Outputs Open, One Input Toggling at f <sub>1</sub> =5 MHz, S=Steady State V <sub>IN</sub> =3.4V or V <sub>IN</sub> =GND	1.2	3.4	mA
		V <sub>CC</sub> =Max., f <sub>0</sub> =10 MHz, 50% Duty Cycle, Outputs Open, Four Inputs Toggling at f <sub>1</sub> =5 MHz, S=Steady State V <sub>IN</sub> ≤0.2V or V <sub>IN</sub> ≥V <sub>CC</sub> -0.2V	1.6	3.2 <sup>[11]</sup>	mA
		V <sub>CC</sub> =Max., f <sub>0</sub> =10 MHz, 50% Duty Cycle, Outputs Open, Four Inputs Toggling at f <sub>1</sub> =5 MHz, S=Steady State V <sub>IN</sub> =3.4V or V <sub>IN</sub> =GND	2.9	8.2 <sup>[11]</sup>	mA

**Notes:**

8. Per TTL driven input (V<sub>IN</sub>=3.4V); all other inputs at V<sub>CC</sub> or GND.
9. This parameter is not directly testable, but is derived for use in Total Power Supply calculations.
10. I<sub>C</sub> = I<sub>QUIESCENT</sub> + I<sub>INPUTS</sub> + I<sub>DYNAMIC</sub>  
I<sub>C</sub> = I<sub>CC</sub> + ΔI<sub>CCD<sub>H</sub></sub> N<sub>T</sub> + I<sub>CCD</sub> (f<sub>0</sub>/2 + f<sub>1</sub> N<sub>I</sub>)  
I<sub>CC</sub> = Quiescent Current with CMOS input levels  
ΔI<sub>CC</sub> = Power Supply Current for a TTL HIGH input (V<sub>IN</sub>=3.4V)  
D<sub>H</sub> = Duty Cycle for TTL inputs HIGH

- N<sub>T</sub> = Number of TTL inputs at D<sub>H</sub>  
I<sub>CCD</sub> = Dynamic Current caused by an input transition pair (HLH or LHL)  
f<sub>0</sub> = Clock frequency for registered devices, otherwise zero  
f<sub>1</sub> = Input signal frequency  
N<sub>I</sub> = Number of inputs changing at f<sub>1</sub>

- All currents are in milliamps and all frequencies are in megahertz.  
11. Values for these conditions are examples of the I<sub>CC</sub> formula. These limits are guaranteed but not tested.

**Switching Characteristics** Over the Operating Range

Parameter	Description	FCT399T				FCT399AT				Unit	Fig. No. <sup>[13]</sup>
		Military		Commercial		Military		Commercial			
		Min. <sup>[12]</sup>	Max.	Min. <sup>[12]</sup>	Max.	Min. <sup>[12]</sup>	Max.	Min. <sup>[12]</sup>	Max.		
t <sub>PLH</sub> t <sub>PHL</sub>	Propagation Delay CP to Q	3.0	11.5	3.0	10.0	2.5	7.5	2.5	7.0	ns	1, 5
t <sub>S</sub>	Set-Up Time HIGH or LOW I <sub>n</sub> to CP	4.5		3.5		4.0		3.5		ns	4
t <sub>H</sub>	Hold Time HIGH or LOW I <sub>n</sub> to CP	1.5		1.0		1.0		1.0		ns	4
t <sub>S</sub>	Set-Up Time HIGH or LOW S to CP	9.5		8.5		9.0		8.5		ns	4
t <sub>H</sub>	Hold Time HIGH or LOW S to CP	0		0		0		0		ns	4
t <sub>w</sub>	Clock Pulse Width <sup>[6]</sup> HIGH or LOW	7.0		5.0		6.0		5.0		ns	5

Parameter	Description	FCT399CT				Unit	Fig. No. <sup>[13]</sup>
		Military		Commercial			
		Min. <sup>[12]</sup>	Max.	Min. <sup>[12]</sup>	Max.		
t <sub>PLH</sub> t <sub>PHL</sub>	Propagation Delay CP to Q	2.5	6.6	2.5	6.1	ns	1, 5
t <sub>S</sub>	Set-Up Time, HIGH or LOW, I <sub>n</sub> to CP	4.0		3.5		ns	4
t <sub>H</sub>	Hold Time, HIGH or LOW, I <sub>n</sub> to CP	1.0		1.0		ns	4
t <sub>S</sub>	Set-Up Time, HIGH or LOW, S to CP	9.0		8.5		ns	4
t <sub>H</sub>	Hold Time, HIGH or LOW, S to CP	0		0		ns	4
t <sub>w</sub>	Clock Pulse Width <sup>[6]</sup> HIGH or LOW	6.0		5.0		ns	5

**Notes:**

12. Minimum limits are guaranteed but not tested on Propagation Delays.

13. See "Parameter Measurement Information" in the General Information Section.



**Ordering Information**

Speed (ns)	Ordering Code	Package Name	Package Type	Operating Range
6.1	CY74FCT399CTPC	P1	16-Lead (300-Mil) Molded DIP	Commercial
	CY74FCT399CTQC	Q1	16-Lead (150-Mil) QSOP	
	CY74FCT399CTSOC	S1	16-Lead (300-Mil) Molded SOIC	
6.6	CY54FCT399CTDMB	D2	16-Lead (300-Mil) CerDIP	Military
	CY54FCT399CTLMB	L61	20-Pin Square Leadless Chip Carrier	
7.0	CY74FCT399ATPC	P1	16-Lead (300-Mil) Molded DIP	Commercial
	CY74FCT399ATQC	Q1	16-Lead (150-Mil) QSOP	
	CY74FCT399ATSOC	S1	16-Lead (300-Mil) Molded SOIC	
7.5	CY54FCT399ATDMB	D2	16-Lead (300-Mil) CerDIP	Military
	CY54FCT399ATLMB	L61	20-Pin Square Leadless Chip Carrier	
10.0	CY74FCT399TPC	P1	16-Lead (300-Mil) Molded DIP	Commercial
	CY74FCT399TQC	Q1	16-Lead (150-Mil) QSOP	
	CY74FCT399TSOC	S1	16-Lead (300-Mil) Molded SOIC	
11.5	CY54FCT399TDMB	D2	16-Lead (300-Mil) CerDIP	Military
	CY54FCT399TLMB	L61	20-Pin Square Leadless Chip Carrier	

Document #: 38-00280-A