

Dot Matrix

Shape	Part Number	Emitting Color	Emitting Material	Wave Length (nm)	Luminous Intensity IF=10mA (ucd) Min. Max.	Column	Figure No.
0.7"(18mm) 5X7	MHR18A / MHR18C	Red	GaP	700	360 - 900	Anode / Cathode	1
	MUR18A / MUR18C	Red	GaAsP/GaP	625	2200 - 5600	Anode / Cathode	
	MMR18A / MMR18C	Red	GaAlAs	660	5600 - 14000	Anode / Cathode	
	MUG18A / MUG18C	Green	GaP	565	2200 - 5600	Anode / Cathode	
	MUY18A / MUY18C	Yellow	GaAsP/GaP	590	2200 - 5600	Anode / Cathode	
1.88"(47.8mm) 8x8	MURG48A8 / MURG48C8	Red	GaAsP/GaP	625	5600 - 9000	Anode / Cathode	2
		Green	GaP	565	5600 - 9000		

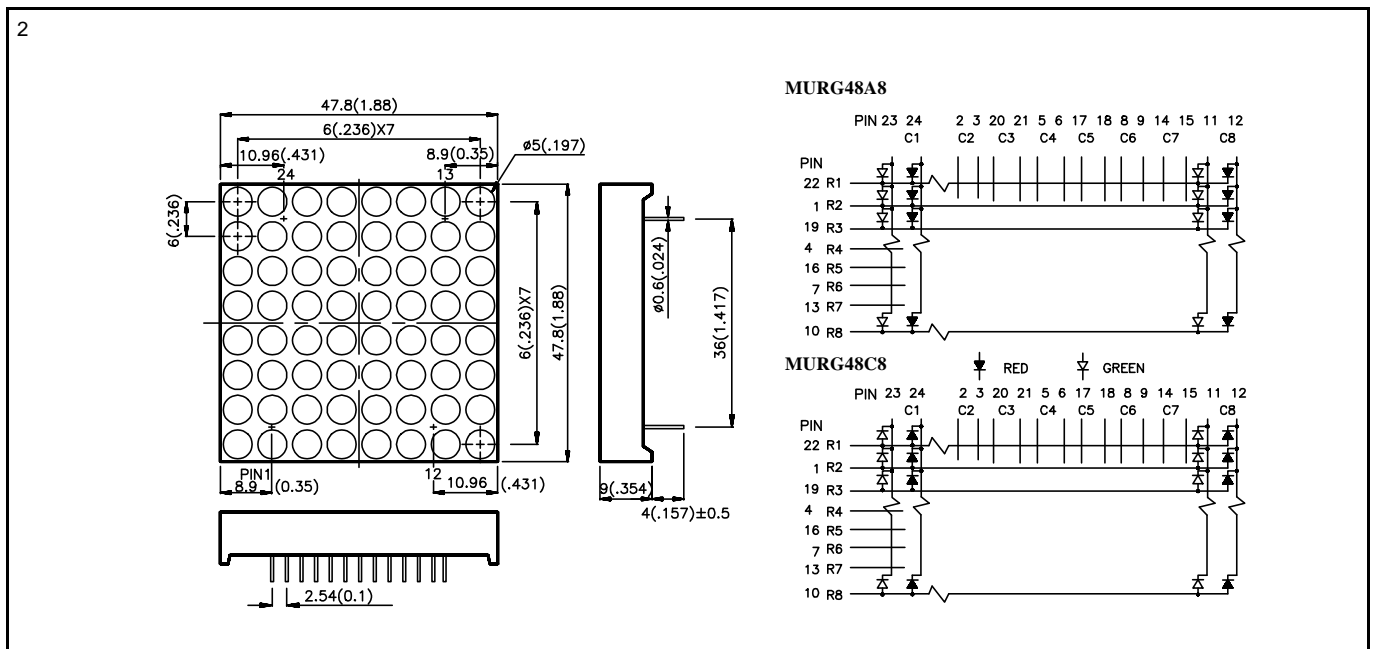
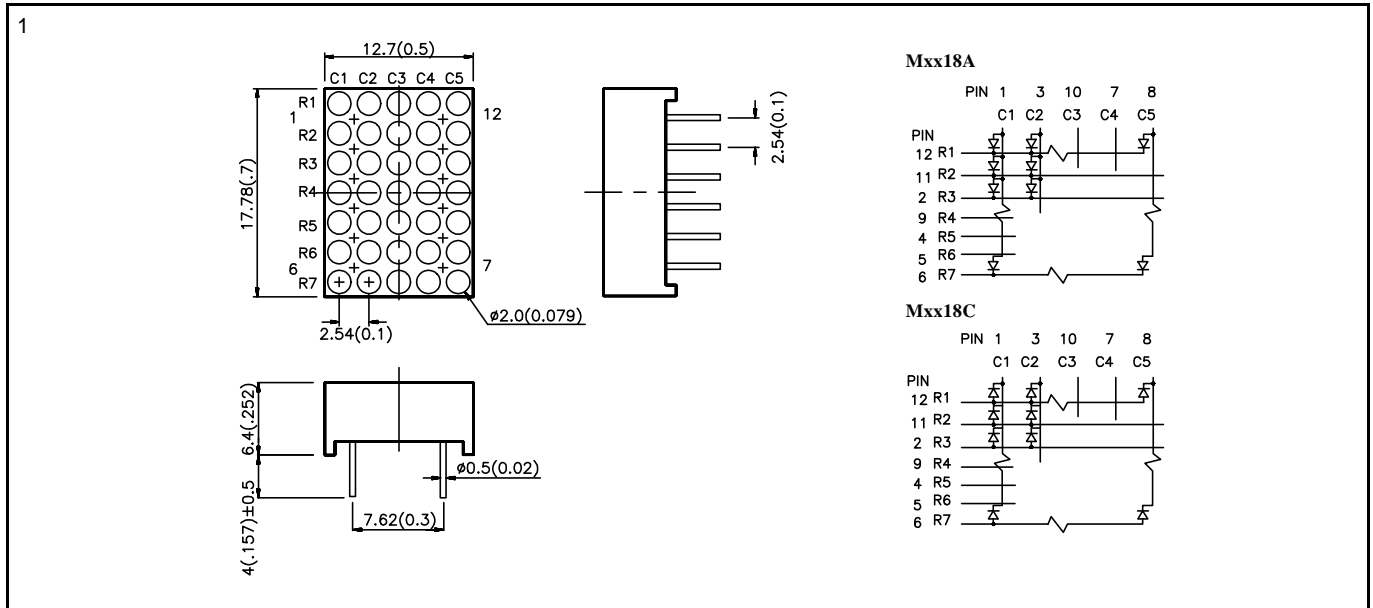

Dot Matrix

Shape	Part Number	Emitting Color	Emitting Material	Wave Length (nm)	Luminous Intensity IF=10mA (ucd) Min. Max.	Column	Figure No.
1.2"(30mm) 5x7	MHR30A / MHR30C	Red	GaP	700	560 - 1400	Anode / Cathode	3
	MUR30A / MUR30C	Red	GaAsP/GaP	625	3600 - 9000	Anode / Cathode	
	MMR30A / MMR30C	Red	GaAlAs	660	5600 - 14000	Anode / Cathode	
	MUG30A / MUG30C	Green	GaP	565	2200 - 5600	Anode / Cathode	
	MUY30A / MUY30C	Yellow	GaAsP/GaP	590	2200 - 5600	Anode / Cathode	
	MURG30A / MURG30C	Red	GaAsP/GaP	625	2200 - 9000	Anode / Cathode	
	MURG30A-1A	Red	GaAsP/GaP	625	2200 - 9000	Anode / Cathode	
	MURG30C-1A	Green	GaP	565	2200 - 9000	Anode / Cathode	
	MURG30A-1B	Red	GaAsP/GaP	625	2200 - 9000	Anode / Cathode	
MURG30C-1B	Green	GaP	565	2200 - 9000	Anode / Cathode		

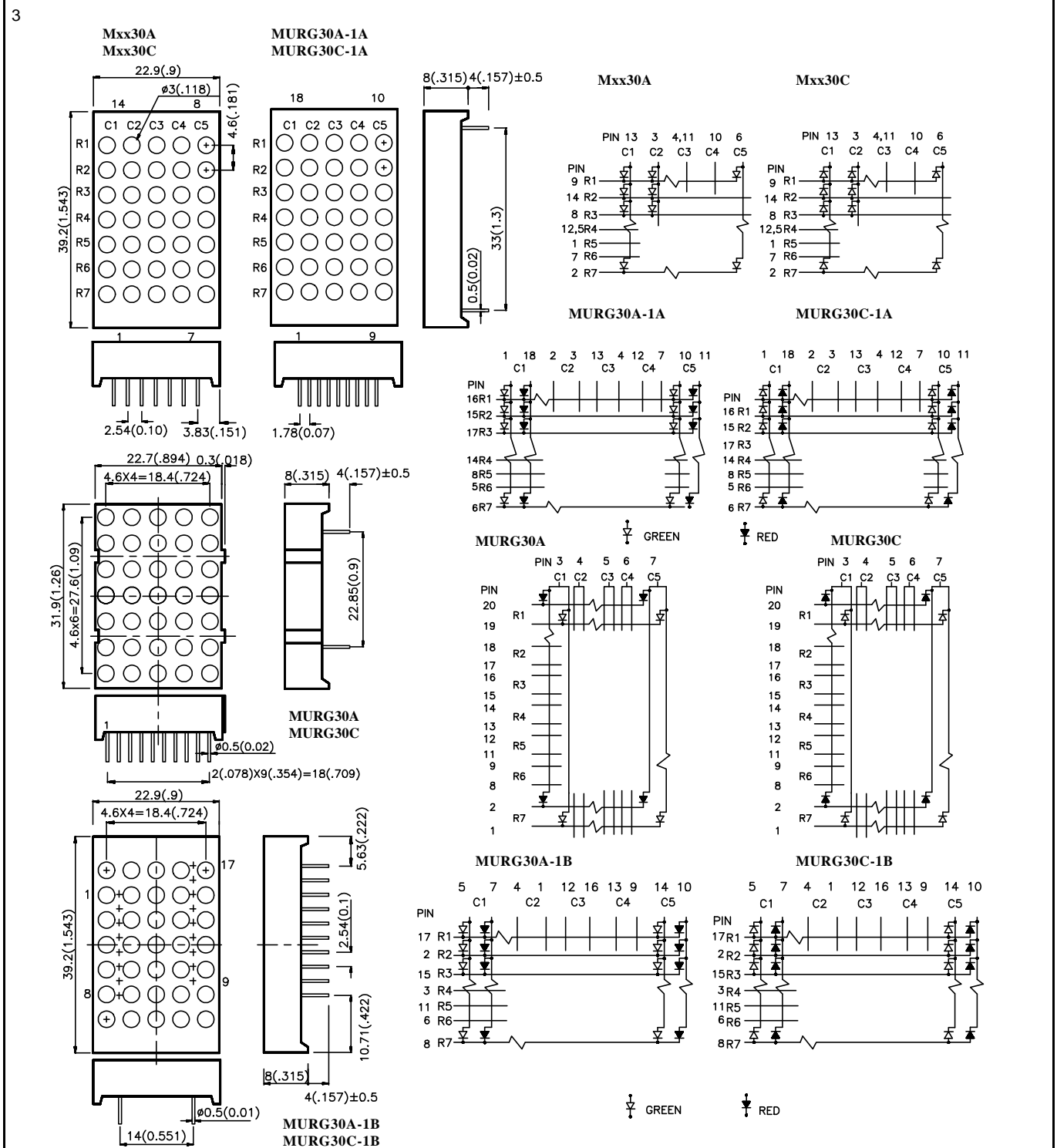

Dot Matrix

Shape	Part Number	Emitting Color	Emitting Material	Wave Length (nm)	Luminous Intensity IF=10mA (ucd)		Column	Figure No.
					Min.	Max.		
1.5"(38mm) 8x8	MHR38A8 / MHR38C8	Red	GaP	700	560 - 1400		Anode / Cathode	4
	MUR38A8 / MUR38C8	Red	GaAsP/GaP	625	3600 - 9000		Anode / Cathode	
	MMR38A8 / MMR38C8	Red	GaAlAs	660	5600 - 14000		Anode / Cathode	
	MUG38A8 / MUG38C8	Green	GaP	565	2200 - 5600		Anode / Cathode	
	MUY38A8 / MUY38C8	Yellow	GaAsP/GaP	590	2200 - 5600		Anode / Cathode	
	MURG38A8 / MURG38C8	Red	GaAsP/GaP	625	2200 - 9000		Anode / Cathode	
Green		GaP	565	2200 - 9000				

4

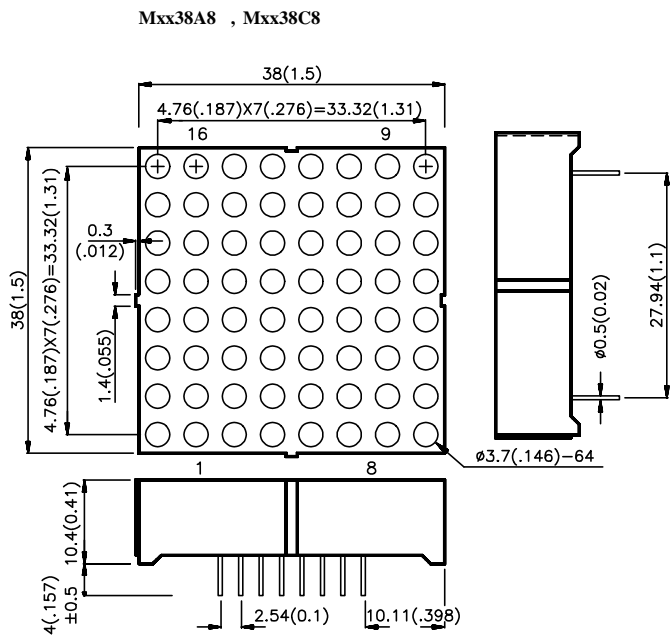

Mxx38A8

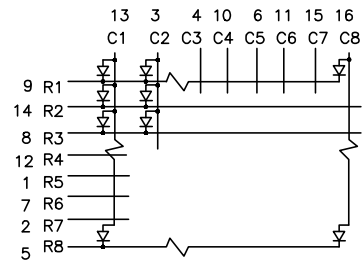

Mxx38C8

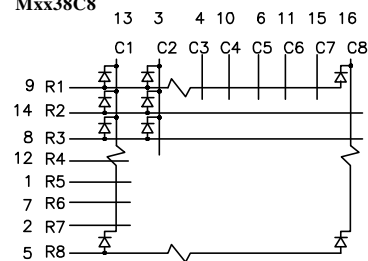

MURG38A8 , MURG38C8

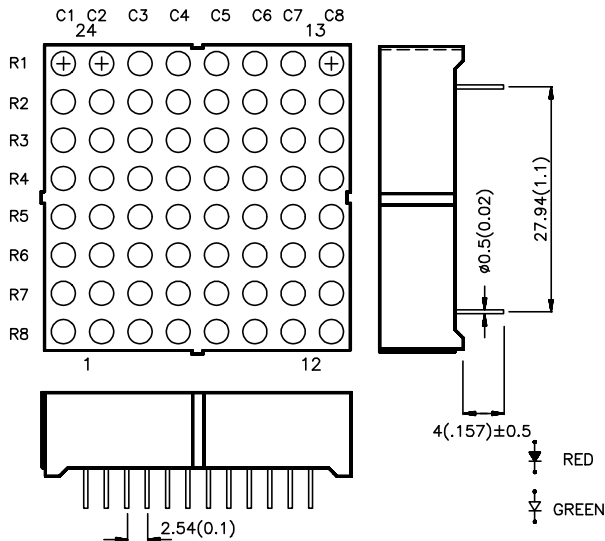

MURG38A8

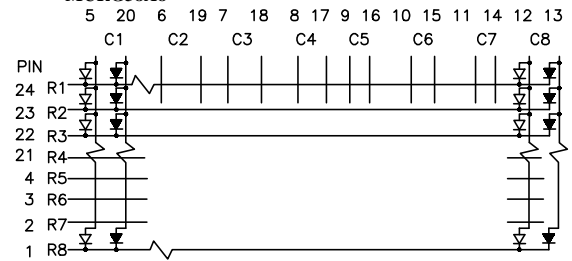

MURG38C8

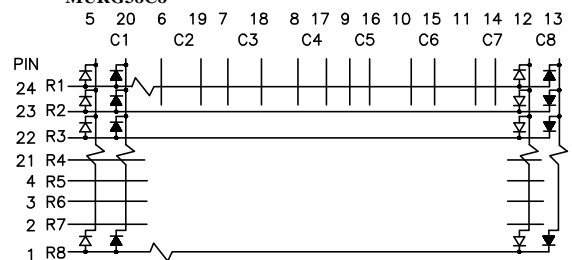

Dot Matrix

Shape	Part Number	Emitting Color	Emitting Material	Wave Length (nm)	Luminous Intensity IF=10mA (ucd) Min. Max.	Column	Figure No.
2.0"(50mm) 5x7	MHR50A / MHR50C	Red	GaP	700	560 - 1400	Anode / Cathode	5
	MUR50A / MUR50C	Red	GaAsP/GaP	625	3600 - 9000	Anode / Cathode	
	MMR50A / MMR50C	Red	GaAlAs	660	9000 - 31000	Anode / Cathode	
	MUG50A / MUG50C	Green	GaP	565	2200 - 5600	Anode / Cathode	
	MUY50A / MUY50C	Yellow	GaAsP/GaP	590	2200 - 5600	Anode / Cathode	
	MURG50A / MURG50C	Red	GaAsP/GaP	625	3600 - 9000	Anode / Cathode	
		Green	GaP	565	2200 - 9000		
	MURG50A-A MURG50C-A	Red	GaAsP/GaP	625	3600 - 9000	Anode / Cathode	
		Green	GaP	565	2200 - 9000		
	MURG50A-1A MURG50C-1A	Red	GaAsP/GaP	625	3600 - 9000	Anode / Cathode	
Green		GaP	565	2200 - 9000			

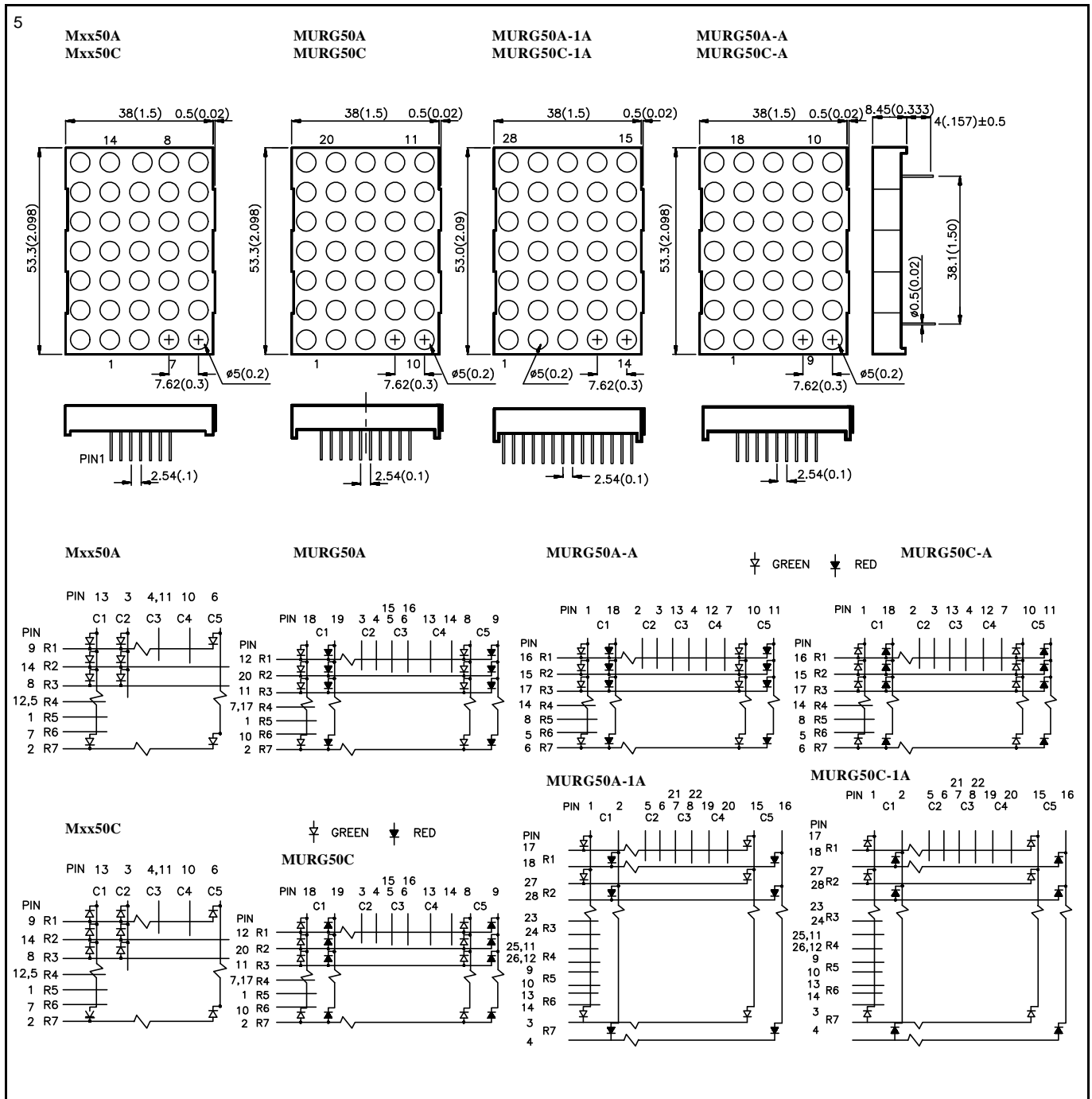

Dot Matrix

Shape	Part Number	Emitting Color	Emitting Material	Wave Length (nm)	Luminous Intensity IF=10mA (ucd) Min. Max.	Column	Figure No.
2.3"(60mm) 8x8	MHR60A8 / MHR60C8	Red	GaP	700	560 - 1400	Anode / Cathode	6
	MUR60A8 / MUR60C8	Red	GaAsP/GaP	625	3600 - 9000	Anode / Cathode	
	MMR60A8 / MMR60C8	Red	GaAlAs	660	14000 - 31000	Anode / Cathode	
	MUG60A8 / MUG60C8	Green	GaP	565	2200 - 5600	Anode / Cathode	
	MUY60A8 / MUY60C8	Yellow	GaAsP/GaP	590	2200 - 5600	Anode / Cathode	
	MURG60A8/MURG60C8 MURG60A8-A/ MURG60C8-A	Red Green	GaAsP/GaP GaP	625 565	3600 - 9000 2200 - 5600	Anode / Cathode	

6

A : Mxx60A8 , Mxx60C8
 B : MURG60A8-A , MURG60C8-A
 C : MURG60A8 , MURG60C8

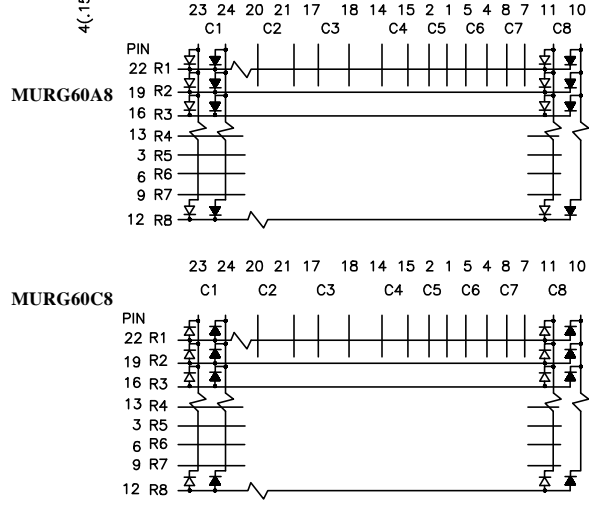
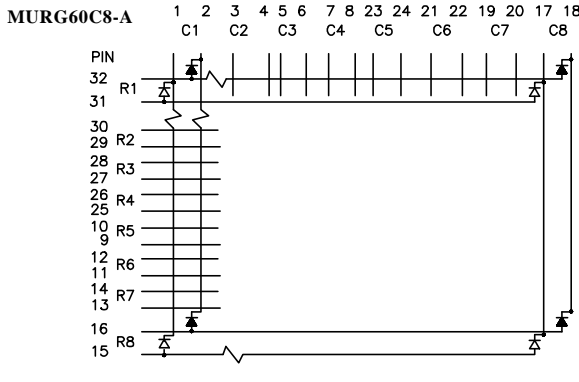
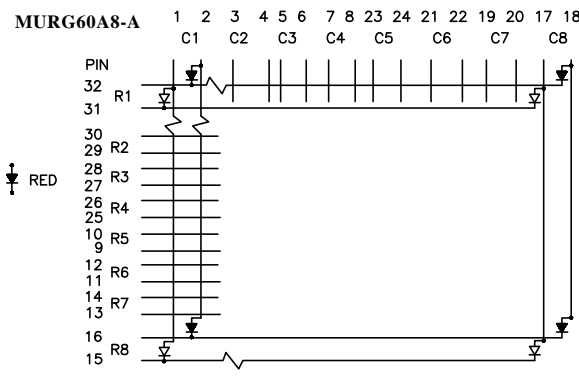
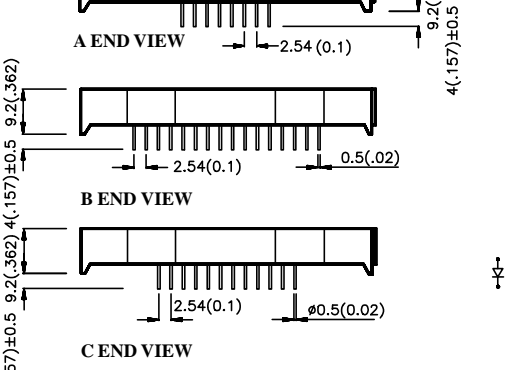
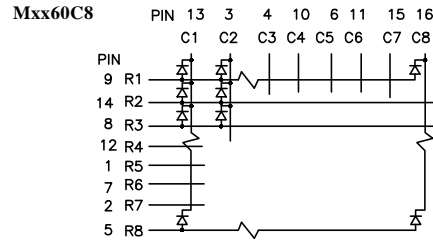
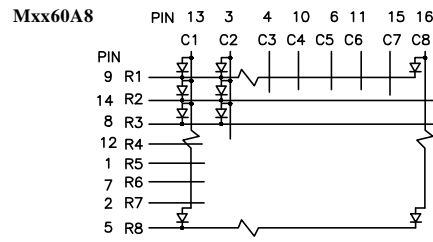
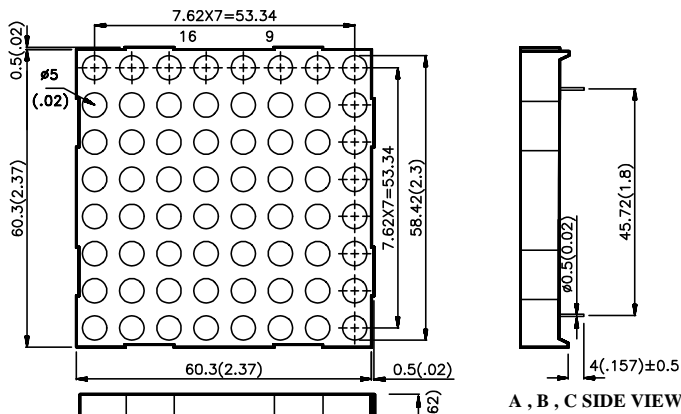

Dot Matrix

Shape	Part Number	Emitting Color	Emitting Material	Wave Length (nm)	Luminous Intensity IF=10mA (ucd) Min. Max.	Column	Figure No.
2.4"(60.8mm) 5x8	MHR60A / MHR60C	Red	GaP	700	560 - 1400	Anode / Cathode	7
	MUR60A / MUR60C	Red	GaAsP/GaP	625	3600 - 9000	Anode / Cathode	
	MMR60A / MMR60C	Red	GaAlAs	660	14000 - 31000	Anode / Cathode	
	MUG60A / MUG60C	Green	GaP	565	2200 - 5600	Anode / Cathode	
	MUY60A / MUY60C	Yellow	GaAsP/GaP	590	2200 - 5600	Anode / Cathode	
	MURG60A / MURG60C MURG60A-1A MURG60C-1A	Red Green	GaAsP/GaP GaP	625 565	3600 - 9000 2200 - 5600	Anode / Cathode	

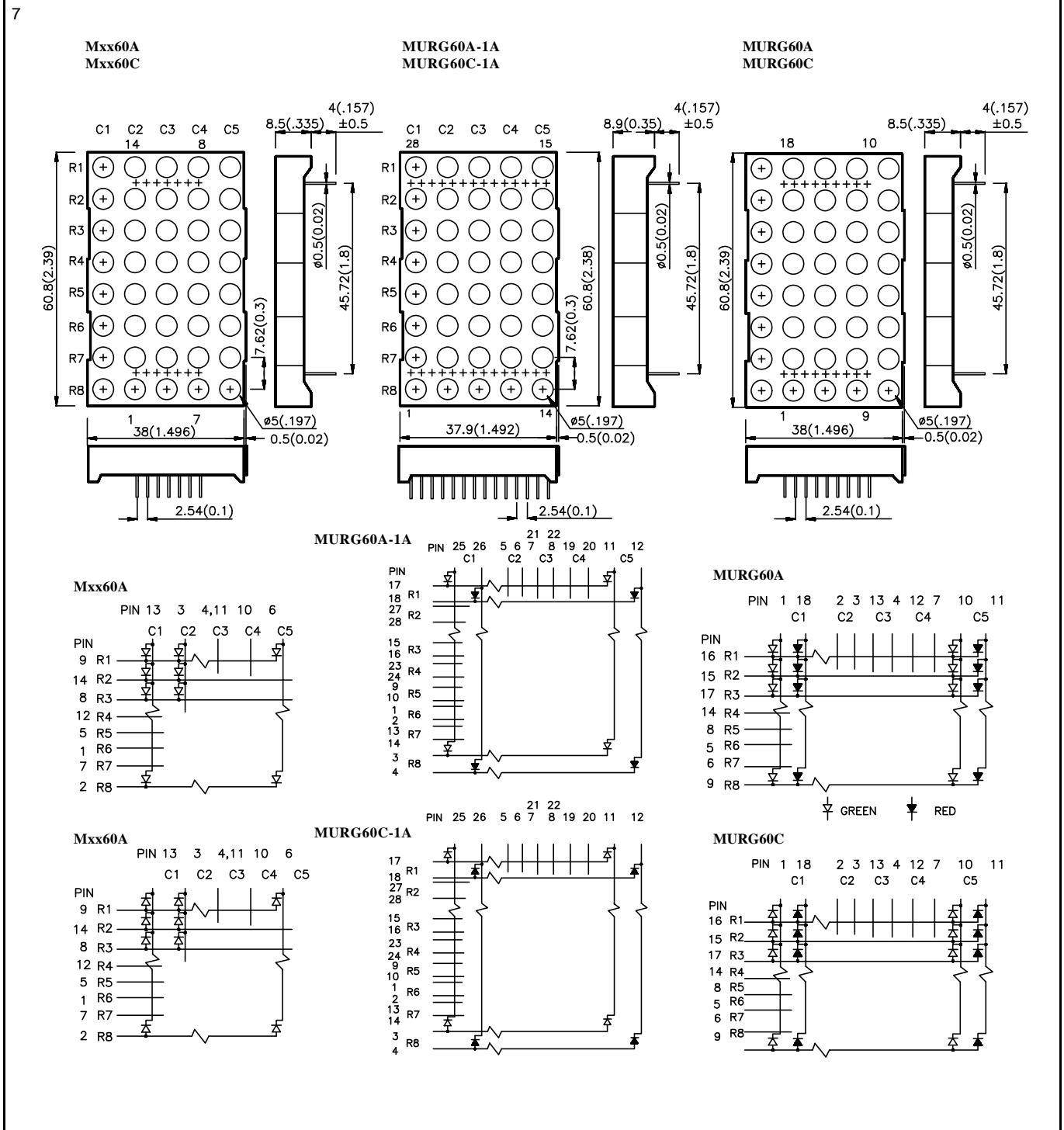

Package Dimensions Units : mm
Tolerance : ±0.25mm (0.01")

Dot Matrix

Shape	Part Number	Emitting Color	Emitting Material	Wave Length (nm)	Luminous Intensity IF=10mA (ucd) Min. Max.	Column	Figure No.
4.0"(100mm) 5x7	MUR100A / MUR100C	Red	GaAsP/GaP	625	3600 - 9000	Anode / Cathode	8
	MMR100A / MMR100C	Red	GaAlAs	660	14000 - 31000	Anode / Cathode	
	MUG100A / MUG100C	Green	GaP	565	2200 - 5600	Anode / Cathode	
	MUY100A / MUY100C	Yellow	GaAsP/GaP	590	2200 - 5600	Anode / Cathode	
	MURG100A / MURG100C MURG100A-1A / MURG100C-1A	Red Green	GaAsP/GaP GaP	625 565	3600 - 9000 2200 - 5600	Anode / Cathode	

