

4ch 75Ω Driver built-in LPF for DC-coupled I/O Monolithic IC MM1860XFBEH

Outline

This IC is a 4ch 75Ω driver with a built-in LPF for DC-coupled I/O without requiring the output capacitor. This IC is compatible with operating voltage of 3.3V and 5V systems, and can be used in such portable equipment as digital still camera as well as such stationary equipment as BD/DVD recorder, BD/DVD player. This IC includes 3ch 75Ω driver for progressive signal and it is best suited to a DVD player and DVD recorder.

Features

1. Built-in LPF (LPF 6.75MHz 1ch + LPF 13.5MHz 3ch) 75Ω driver
2. Supports : Progressive signal
3. Output capacitor unnecessary
4. Operating supply voltage 3.0~5.3V
(Support 3.3V and 5V systems)
5. Operating ambient temperature -40~+85°C

Package

SOP-10A

Applications

1. BD/DVD Players
2. BD/DVD Recorders
3. Digital still camera
4. Other mobile equipment

Block Diagram

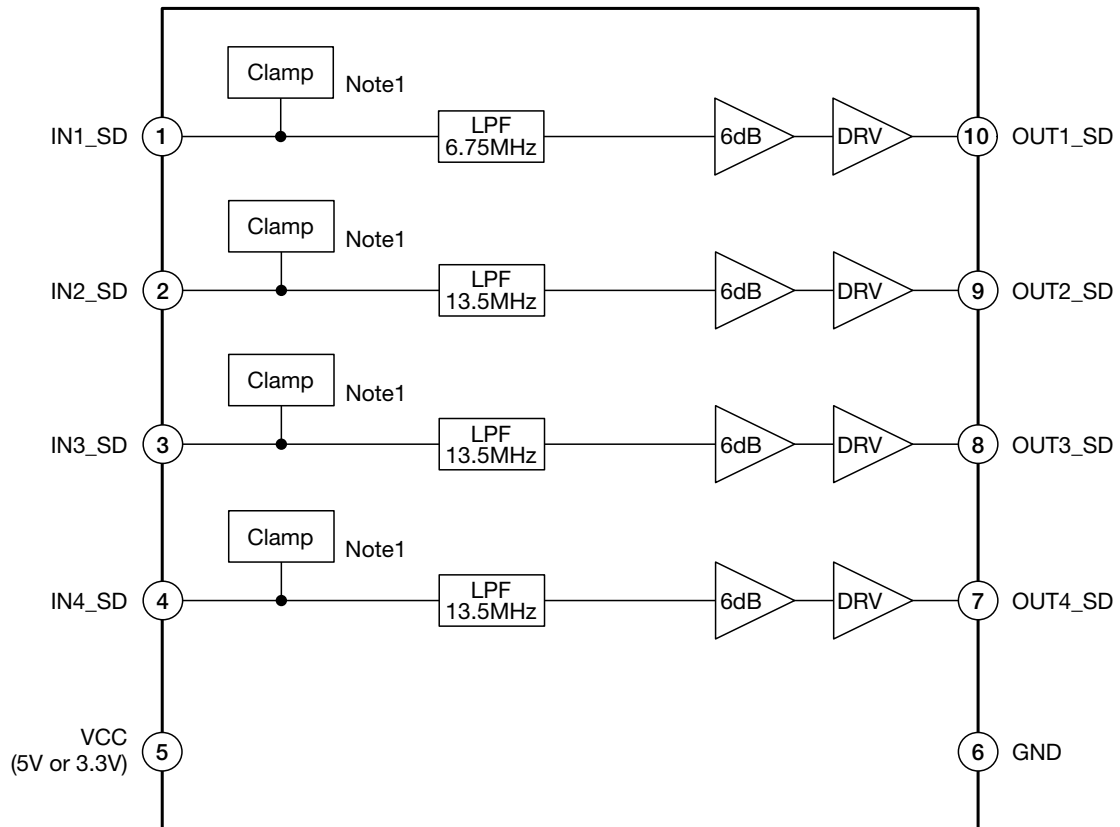

Note1 : It is possible to change to the bias input by external resistance.

Pin Assignment

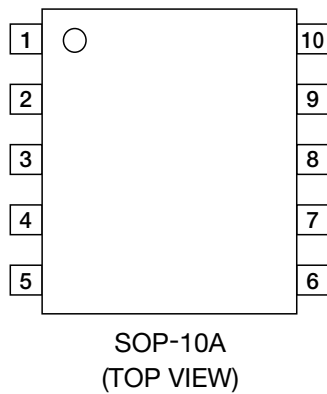

1	IN1_SD
2	IN2_SD
3	IN3_SD
4	IN4_SD
5	V _{CC}
6	GND
7	OUT4_SD
8	OUT3_SD
9	OUT2_SD
10	OUT1_SD

Pin Description

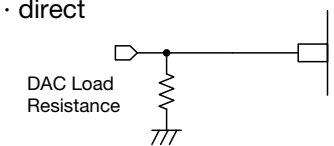
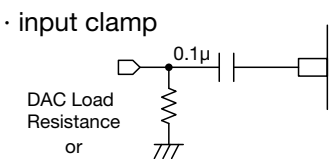
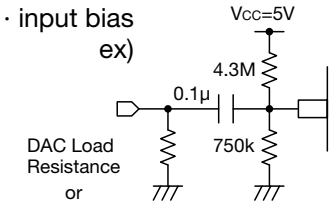
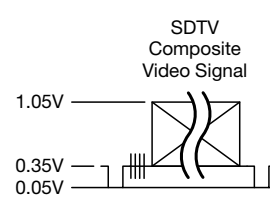
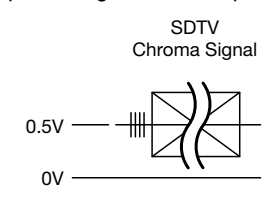
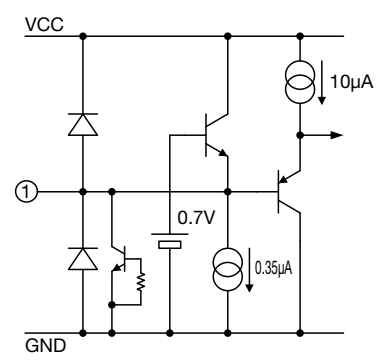
Pin No.	Pin name	Pin description
1	IN1_SD	Function
		<p>Video Signal Input</p> <p>Pin to input Video signals.</p> <p>It is an input clamping circuit where the sync-tip level of the video signal is 0V. Because it is possible to input it according to the GND level, it is possible to connect directly with the DAC output. The input capacitor is unnecessary.</p> <p>Moreover, it functions as a bias input terminal by the operation point setting by external resistance.</p> <p>Pin Voltage : 0.1V(typ.)</p>
		External circuit
		Input signal
		<div style="display: flex; justify-content: space-between;"> <div style="width: 45%;"> <p>· direct</p>  <p>· input clamp</p>  <p>· input bias ex)</p>  <p>when not using it : Open</p> </div> <div style="width: 45%;"> <p>· Typical input voltage levels at input clamp</p>  <p>· Typical input voltage levels at input bias</p>  </div> </div>
Equivalent circuit diagram		
		

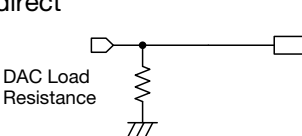
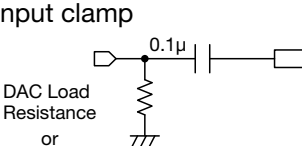
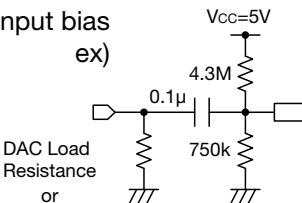
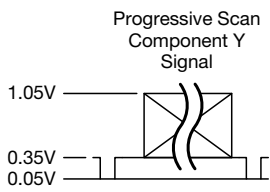
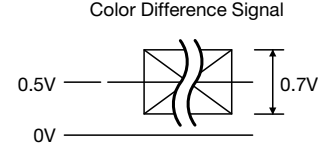
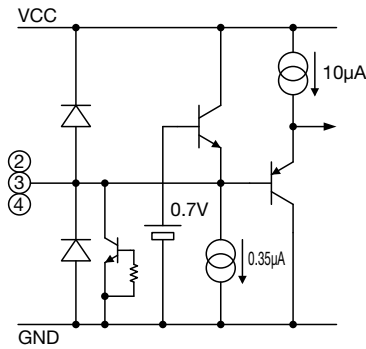
Pin No.	Pin name	Pin description
		Function
		<p>Video Signal Input Pin to input Video signals. It is an input clamping circuit where the sync-tip level of the video signal is 0V. Because it is possible to input it according to the GND level, it is possible to connect directly with the DAC output. The input capacitor is unnecessary. Moreover, it functions as a bias input terminal by the operation point setting by external resistance. Pin Voltage : 0.15V(typ.)</p>
		External circuit
		<p>· direct</p>  <p>· input clamp</p>  <p>· input bias</p> <p>ex)</p>  <p>when not using it : Open</p>
		Input signal
2	IN2_SD	<p>· Typical input voltage levels at input clamp</p>  <p>· Typical input voltage levels at input bias</p> 
3	IN3_SD	
4	IN4_SD	
Equivalent circuit diagram		
		

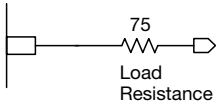
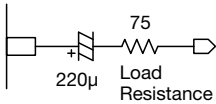
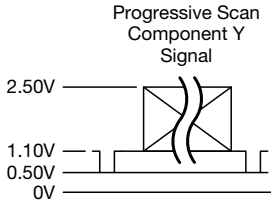
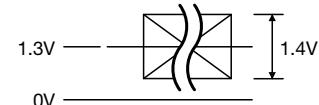
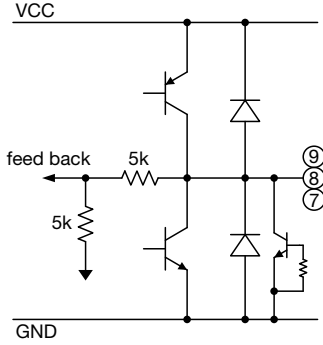
Pin No.	Pin name	Pin description	
<p>9 8 7</p>	<p>OUT2_SD OUT3_SD OUT4_SD</p>	<p>Function</p>	
		<p>Video Signal Output Pin to output Video signals. "The DC-coupled" and "the AC-coupled" can be selected. When you can allow the DC output level 0.5V, it is possible to connect directly with the load resistance. Pin Voltage : 0.6V(typ.)</p>	
		<p style="text-align: center;">External circuit</p> <p>· direct</p>  <p>· AC-Coupled</p>  <p>when not using it : Open</p>	<p style="text-align: center;">Output signal</p> <p>· Typical output voltage levels at input clamp</p>  <p>· Typical output voltage levels at input bias</p> 
		<p>Equivalent circuit diagram</p>	
			

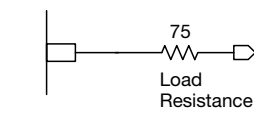
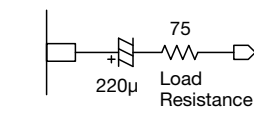
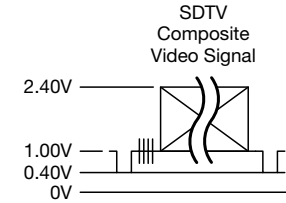
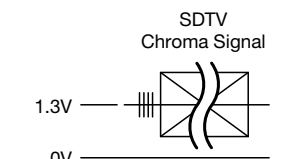
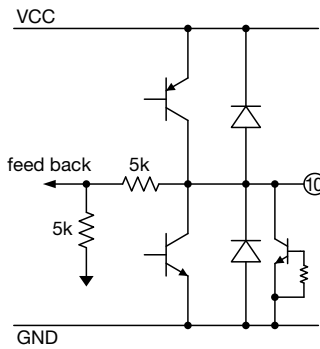
Pin No.	Pin name	Pin description	
10	OUT1_SD	Function	
		<p>Video Signal Output Pin to output Video signals. "The DC-coupled" and "the AC-coupled" can be selected. When you can allow the DC output level 0.5V, it is possible to connect directly with the load resistance. Pin Voltage : 0.5V(typ.)</p>	
		External circuit	Output signal
		<div style="display: flex; justify-content: space-between;"> <div data-bbox="499 607 970 1167" style="width: 45%;"> <p>· direct</p>  <p>· AC-Coupled</p>  <p>when not using it : Open</p> </div> <div data-bbox="970 607 1465 1167" style="width: 45%;"> <p>· Typical output voltage levels at input clamp</p>  <p>· Typical output voltage levels at input bias</p>  </div> </div>	
		Equivalent circuit diagram	
			

Pin No.	Pin name	Pin description	
5	Vcc	Function	
		<p>Voltage Supply It is a supply voltage impression terminal. Please impress 3.3V or 5.0V. Please arrange a bypass capacitor to the terminal latest as much as possible.</p>	
		External circuit	Equivalent circuit diagram
		Input signal	
		DC Voltag : 3.0V~5.3V (3.3V or 5.0V)	
6	GND	Function	
		<p>GND GND terminal</p>	
		External circuit	Equivalent circuit diagram
		Input signal	

Absolute Maximum Ratings (Except where noted otherwise, Ta=25°C)

Item	Symbol	Ratings	Units
Storage Temperature	Tstg	-55~+150	°C
Operating Temperature	T _{OPR}	-40~+85	°C
Supply Voltage	V _{CCMAX}	-0.3~+6	V
I/O Voltage	V _{I/O MAX}	-0.3~V _{CC} +0.3	V
Junction Temperature	T _{JMAX}	150	°C
Thermal Resistance 1 (Note2)	θ _{ja}	120.6	°C/W
Thermal Resistance 2 (Note2)	θ _{jc}	6.4	°C/W
Power Dissipation (Note2)	P _d	0.9	W

Note2 : Board mounting power dissipation. Board size 25mm×14mm×1mm
 Layer 1 / Material glass epoxy / Wire rate 10%

Recommended Operating Conditions

Item	Symbol	Ratings	Units
Operating Temperature	T _{OPR}	-40~+85	°C
Operating Voltage	V _{CCOP}	3.0~5.3	V

Electrical Characteristics 1 (Except where noted otherwise $V_{CC}=5V$, $T_a=25^{\circ}C$)

Item	Symbol	Measurement conditions	Min.	Typ.	Max.	Units
[Current Consumption : 5pin]						
Supply Current 1	I_{CC1}	No signal, No load	21	32	43	mA
Supply Current 2	I_{CC2}	No signal, $R_L=150\Omega$ direct	34	45	56	
[Input Terminal voltage : 1pin]						
Input Terminal 1	V_{IN1}	No signal		0.10		V
Input Sync Tip Level 1	$V_{INsync1}$	AC-coupled, Video signal input		0.05		
[Output Terminal voltage : 10pin]						
Output Terminal 1	V_{OUT1}	No signal		0.50		V
Output Sync Tip Level 1	$V_{OUTsync1}$	AC-coupled, Video signal input		0.40		
[Input Terminal voltage : 2, 3, 4pin]						
Input Terminal 2	V_{IN2}	No signal		0.15		V
Input Sync Tip Level 2	$V_{INsync2}$	AC-coupled, Video signal input		0.05		
[Output Terminal voltage : 7, 8, 9pin]						
Output Terminal 2	V_{OUT2}	No signal		0.60		V
Output Sync Tip Level 2	$V_{OUTsync2}$	AC-coupled, Video signal input		0.50		
[10pin]						
Voltage Gain 1	G_{VSD1}	SIN wave : 1V, $f=100kHz$	5.8	6.0	6.2	dB
Frequency Characteristic 1	f_{SD1}	SIN wave : 1V, 6.75MHz/100kHz	-1	0	+1	dB
Attenuation Characteristic 1	Att_{SD1}	SIN wave : 1V, 27MHz/100kHz		-34	-24	dB
Group Delay 1	t_{GDSD1}	at 100kHz		40	80	ns
Group Delay Deviation 1	Δt_{GDSD1}	to 3.58MHz		3	10	ns
		to 4.43MHz		5	10	
		to 6MHz		10	20	
Output Dynamic Range 1	DR_{SD1}	SIN wave : 100kHz, THD = 1%	2.6	4.5		V
Differential Gain	DG_{SD1}	Staircase signal 1V		0.5	2.0	%
Differential Phase	DP_{SD1}	Staircase signal 1V		1.0	2.5	deg
Cross Talk 1	$CT1_{SD1}$	$f=1MHz$, 1V		-60		dB
	$CT2_{SD1}$	$f=4.43MHz$, 1V		-55	-50	
Signal / Noise Ratio 1	SN_{SD1}	BW : 100k-6MHz	70	80		dB

• Any products mentioned in this catalog are subject to any modification in their appearance and others for improvements without prior notification.
 • The details listed here are not a guarantee of the individual products at the time of ordering. When using the products, you will be asked to check their specifications.

Item	Symbol	Measurement conditions	Min.	Typ.	Max.	Units
[7, 8, 9pin]						
Voltage Gain 2	G _{VSD2}	SIN wave : 1V, f=100kHz	5.8	6.0	6.2	dB
Frequency Characteristic 2	f _{SD2}	SIN wave : 1V, 13.5MHz/100kHz	-1	0	+1	dB
Attenuation Characteristic 2	Att _{SD2}	SIN wave : 1V, 54MHz/100kHz		-39	-24	dB
Group Delay 2	t _{GDSD2}	at 100kHz		20	50	ns
Group Delay Deviation 2	Δt _{GDSD2}	to 2MHz		0	10	ns
		to 12MHz		8	15	
Group Delay Deviation 2	Δt _{chGD1SD2}	All channel at 1MHz		0	10	ns
Output Dynamic Range 2	DR _{SD2}	SIN wave : 100kHz, THD = 1%	2.6	4.5		V
Cross Talk 2	CT _{1SD2}	f=1MHz, 1V		-60		dB
	CT _{2SD2}	f=4.43MHz, 1V		-55	-50	
Signal / Noise Ratio 2	SN _{SD2}	BW : 100k~13.5MHz	66	72		dB

Measuring Circuit

(1) AC-Coupled

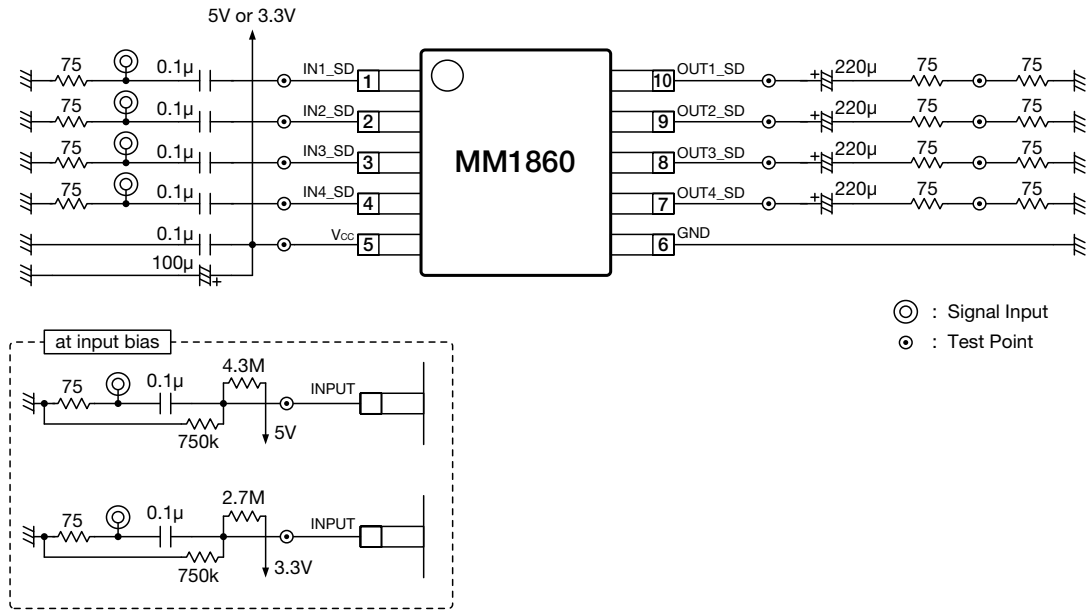

(1) DC-Coupled

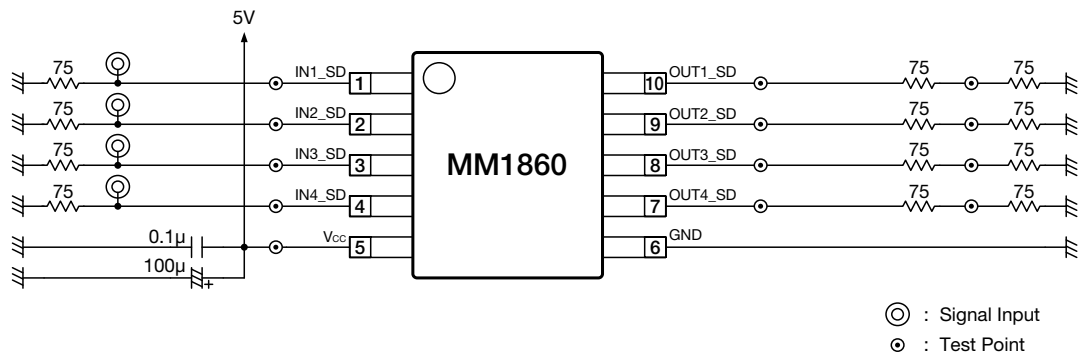

Application Circuit 1

DC-Coupled I/O

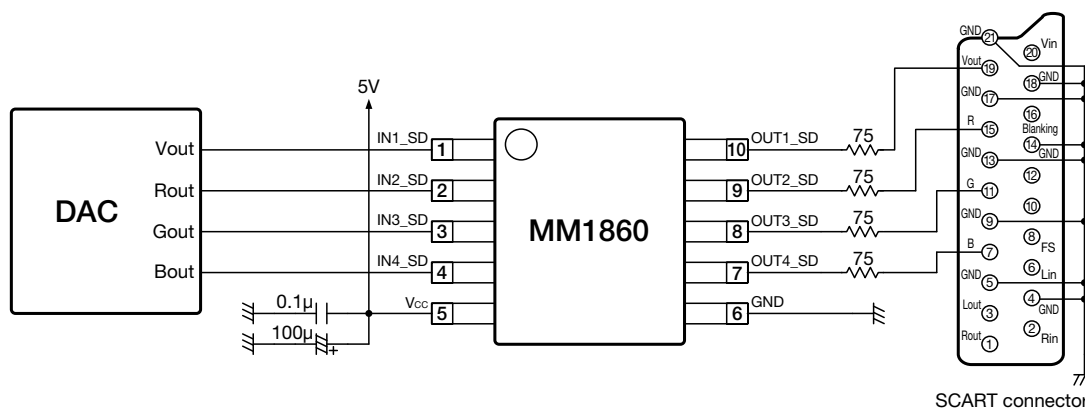

Note3 : Please arrange power supply bypass capacitor near the Vcc terminal (pin).

Note4 : Please arrange the stray capacity component added to a signal output terminal to 20pF or less.

Application Circuit 2

DC-Coupled Input, AC-Coupled Output

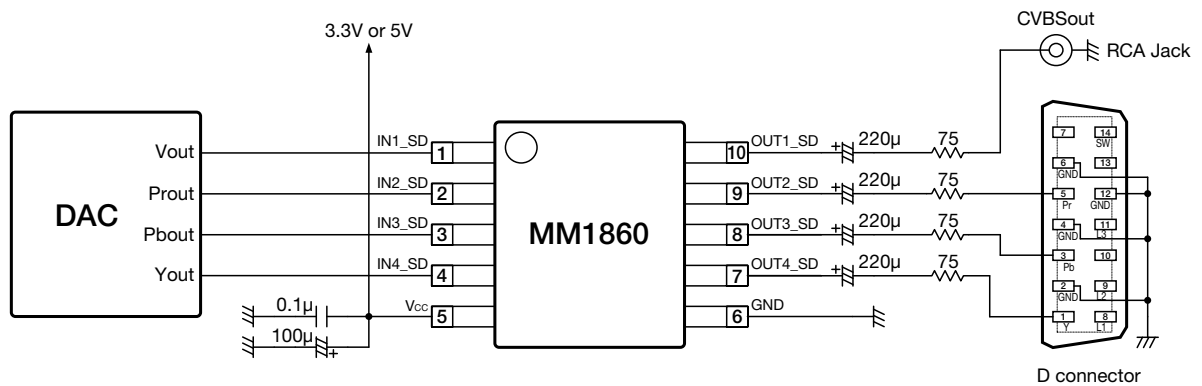

Note5 : When AC-Coupled Output, it is possible to operate by the power-supply voltage 3.3V depending on the operation point of DAC.

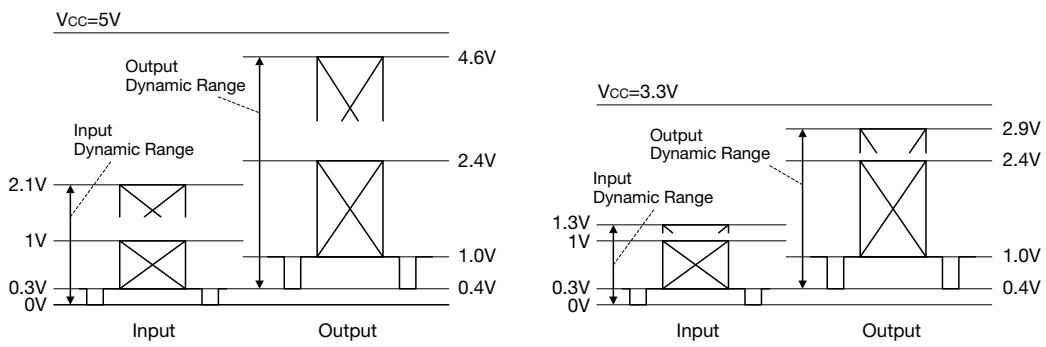

*Typical Voltage Levels

Note6 : Please arrange power supply bypass capacitor near the Vcc terminal (pin).

Note7 : Please arrange the stray capacity component added to a signal output terminal to 20pF or less.

Note8 : Please use it after it confirms it enough by the installing set when you use applied circuit.

Application Circuit 3

AC-Coupled I/O

· Power-supply voltage 5V

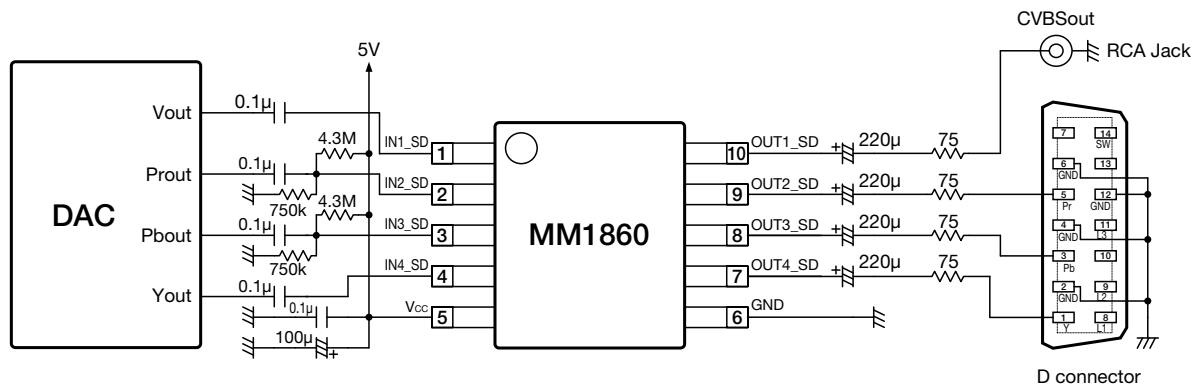

· Power-supply voltage 3.3V

(When AC-Coupled I/O, it is possible to operate by the power-supply voltage 3.3V)

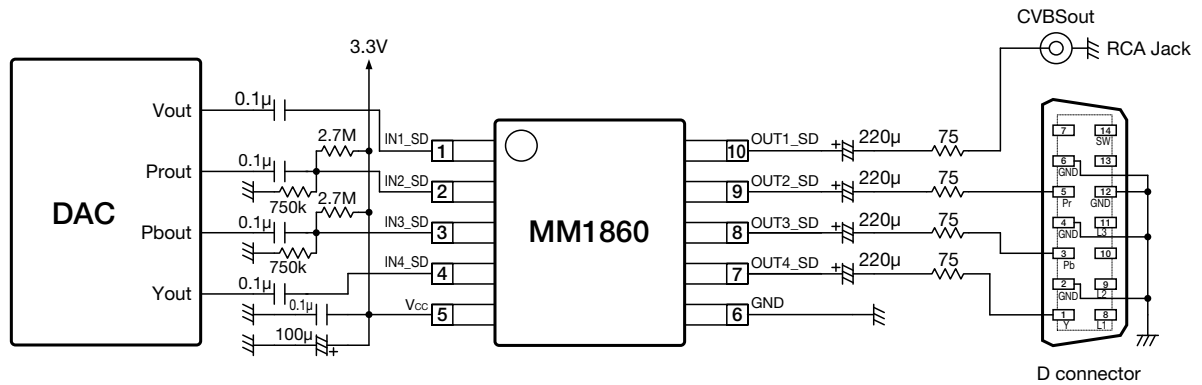

Note9 : "TYPICAL APPLICATION CIRCUIT 3" is an application when the input cannot be connected directly. The connection of this IC and DAC will recommend the DC-Coupled Input , shown by "TYPICAL APPLICATION CIRCUIT 1" or "TYPICAL APPLICATION CIRCUIT 2"

Note10 : Please arrange power supply bypass capacitor near the Vcc terminal (pin).

Note11 : Please arrange the stray capacity component added to a signal output terminal to 20pF or less.

Note12 : Please use it after it confirms it enough by the installing set when you use applied circuit.

Characteristics

(Except where noted otherwise $V_{CC}=5V$, $T_a=25^{\circ}C$)

Supply Current - VCC Characteristic

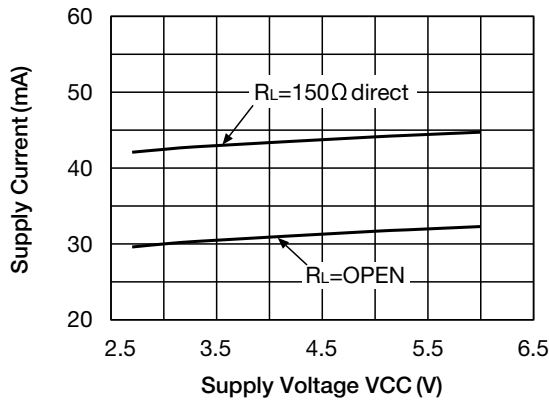

Supply Current - Ta Characteristic

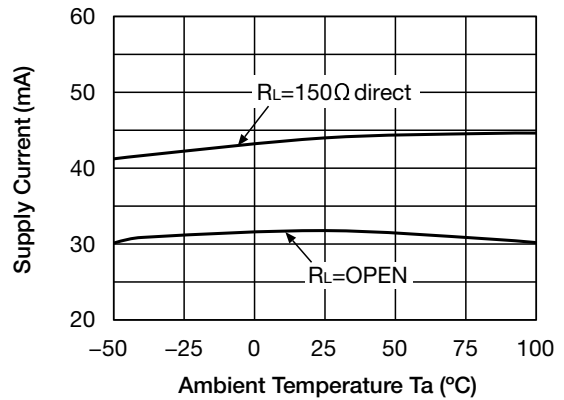

[SD-Composite Video input :1pin SD-Composite Video output : 10pin]

I/O SD Terminal Voltage - VCC Characteristic

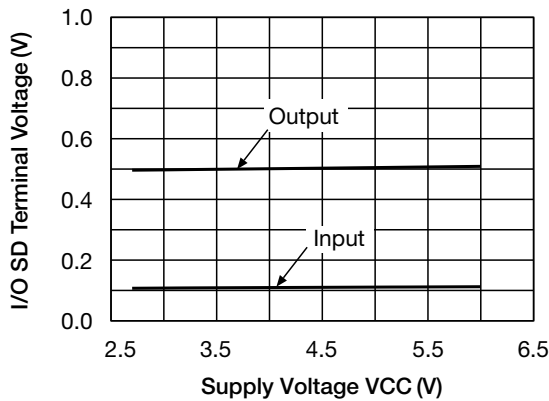

I/O SD Terminal Voltage - Ta Characteristic

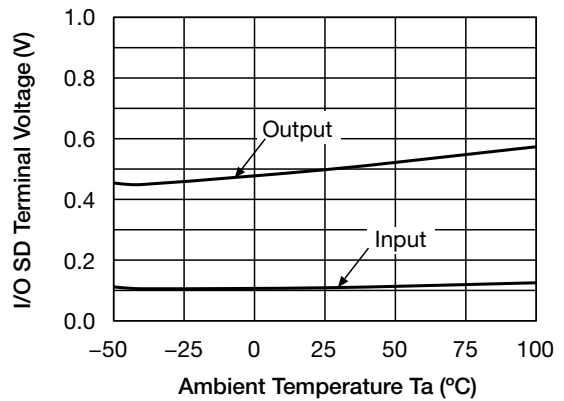

Sync Tip DC Level - VCC Characteristic

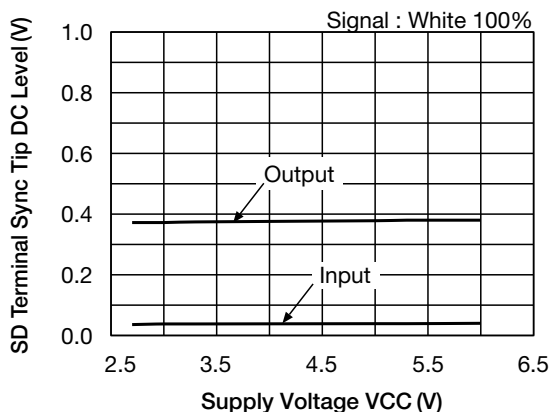

Sync Tip DC Level - VCC Characteristic

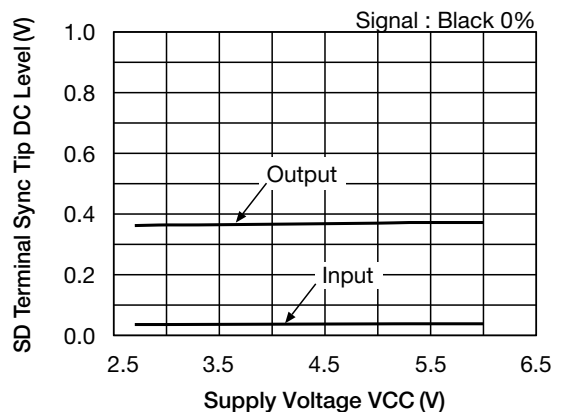

• Any products mentioned in this catalog are subject to any modification in their appearance and others for improvements without prior notification.
 • The details listed here are not a guarantee of the individual products at the time of ordering. When using the products, you will be asked to check their specifications.

[SD-Composite Video channel : 10pin]

■ Voltage Gain - Frequency Characteristic

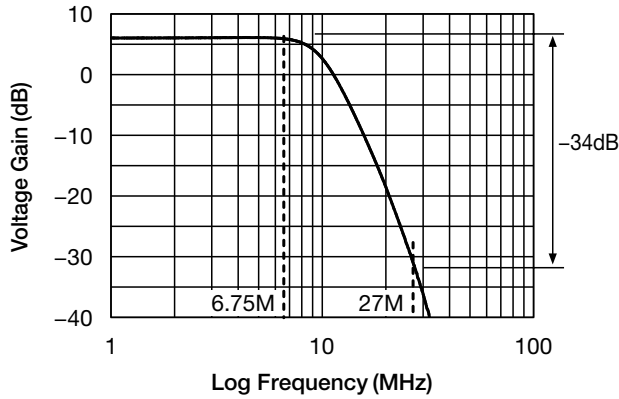

■ Group Delay - Frequency Characteristic

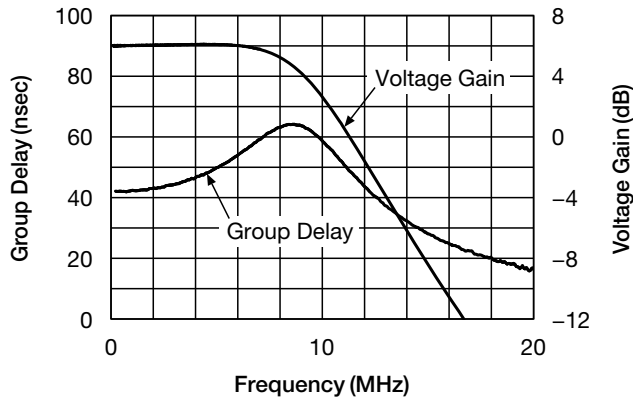

■ Output Dynamic Range - VCC Characteristic

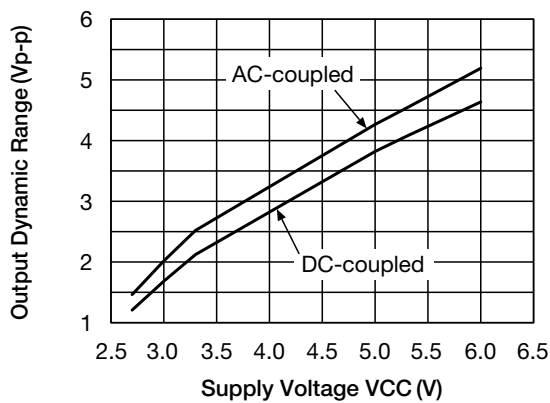

[SD-Progressive Scan input : 2, 3, 4pin SD-Progressive Scan output : 7, 8, 9pin]

I/O HDSD Terminal Voltage - VCC Characteristic

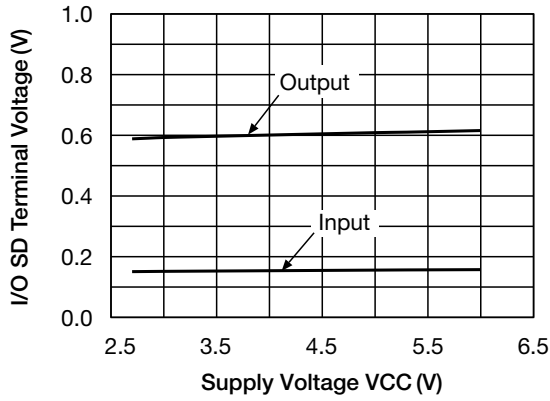

I/O HDSD Terminal Voltage - Ta Characteristic

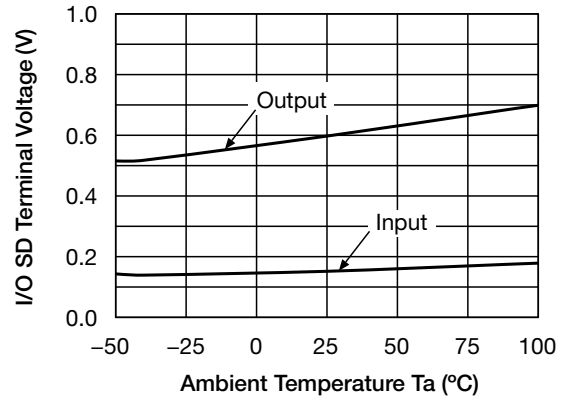

Sync Tip DC Level - VCC Characteristic

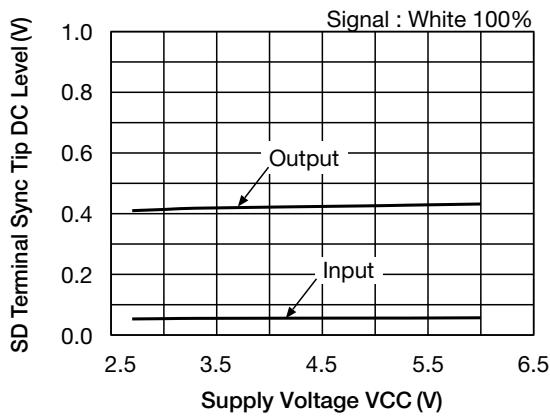

Sync Tip DC Level - VCC Characteristic

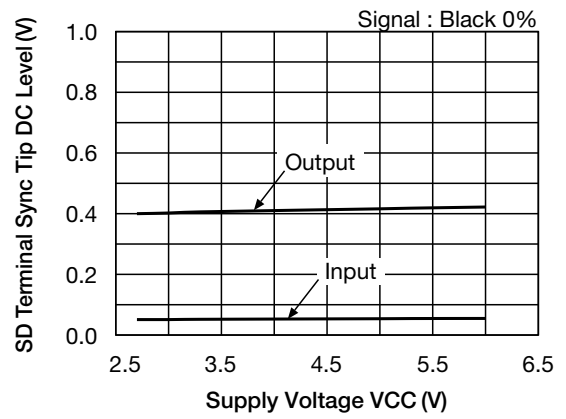

[SD-Progressive Scan channel : 7, 8, 9pin]

Voltage Gain - Frequency Characteristic

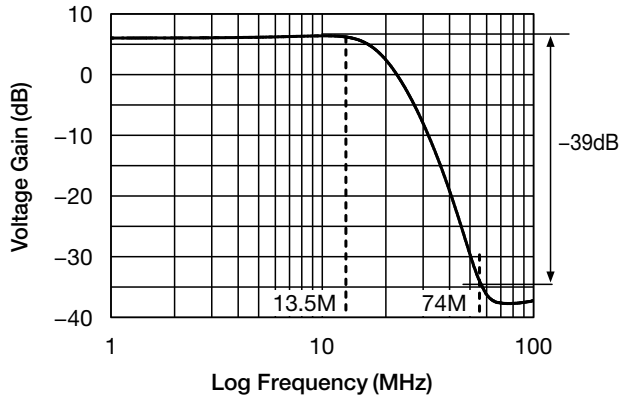

Group Delay - Frequency Characteristic

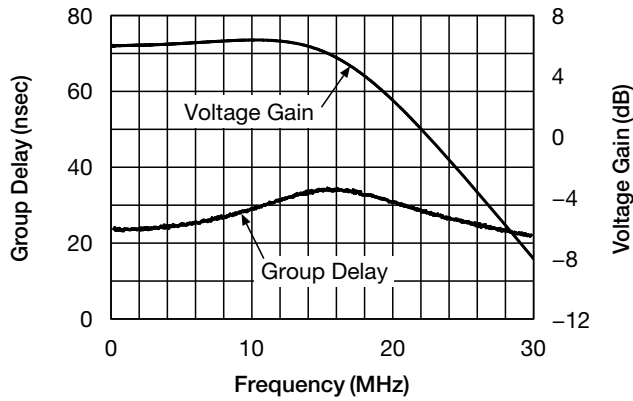

Output Dynamic Range - VCC Characteristic

