



AMP* COAXICON*
50 OHM, R.F. CONNECTORS
SERIES C PANEL JACKS

IS 2259-4

RELEASED	6-23-70
REVISED	12-30-81

The connectors listed below are assembled and crimped as described on Page 2.

Refer to the table below for the Instruction Sheet numbers.

The following publications contain information on additional series C connectors.

Plugs	2259-1
Jacks	2259-2
Bulkhead Jacks	2259-3
Right Angle Plugs	2259-5

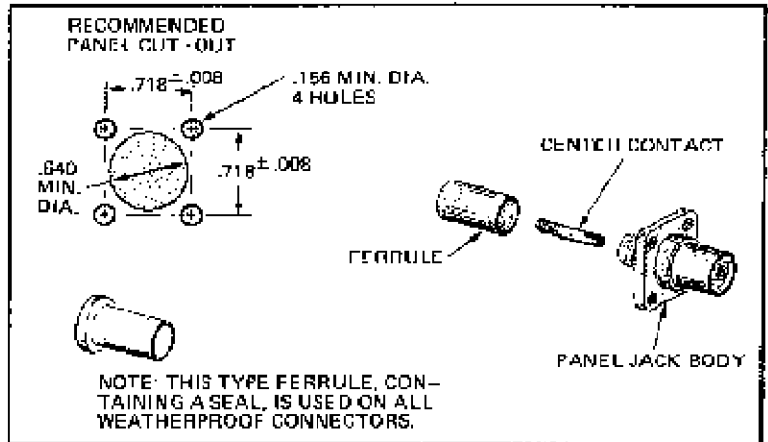

RG/U CABLE	SILVER PLATED P/N		TARNISH RES. P/N		CABLE STRIP DIM.	CRIMPING TOOL	
	Standard	Weatherproof	Standard	Weatherproof		Part No.	Instr. Sheet
8, 8A, 213	225321-2	225409-2	—	—	FIG. 2	220015-1	3331
9, 9A, 9B, 214	225321-1	225409-1	225677-1	—	FIG. 1	220015-1	
	—	225409-6*	—	—	FIG. 1	220015-1	
225	225321-5	225409-4	—	—	FIG. 1	220015-1	
	—	225409-7*	—	—	FIG. 1	220015-1	

* Flange has 4 unthreaded .175 thru holes.

Copyright 1970, 1973, 1981 by AMP Incorporated, Harrisburg, Pa. All Rights Reserved. AMP Incorporated products covered by U.S. and Foreign Patents and/or Patents Pending.

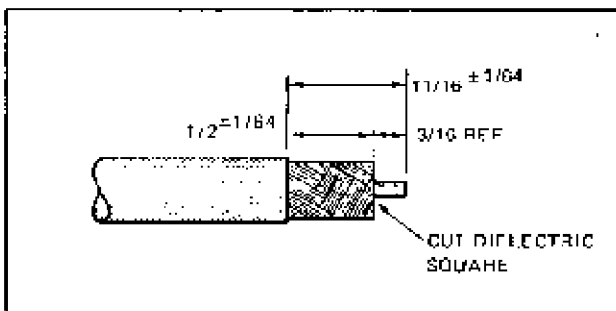

Fig. 1

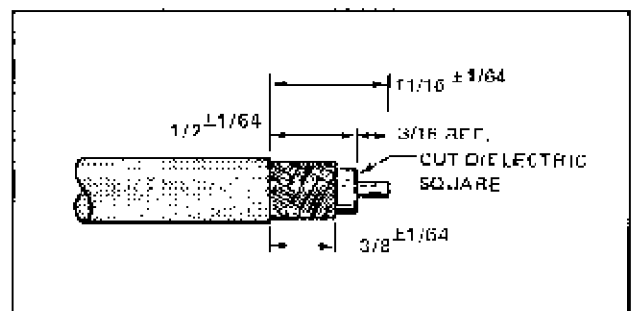

Fig. 2

SUPPORT SLEEVE
OF CONNECTOR

CRIMPED CONTACT

FERRULE



BRAID OVER CONNECTOR
SUPPORT SLEEVE



SLIDE FERRULE FORWARD OVER
BRAID AND SUPPORT SLEEVE

TYPICAL ASSEMBLY PROCEDURE

1. Strike Ferrule on Cable, then strip Cable, Crimp Center Contact (See Tool Instructions referenced in table).
2. Insert Contact into Connector with Braid over Support Sleeve. Pull back lightly on Wire to make sure that Contact is being held captive by the internal locking feature.
3. Slide Ferrule over Braid and crimp Ferrule. (See Tool Instructions referenced in table.)



WEATHERPROOF CONNECTOR

RUBBER SEAL