

FEATURES

- **LOW COST MINIATURE PLASTIC PACKAGE** (SOT-343)
- **LOW NOISE FIGURE:**
0.55 dB typical at 2 GHz
- **HIGH ASSOCIATED GAIN:**
14.5 dB typical at 2 GHz
- **LG = 0.6 μm, WG = 800 μm**
- **TAPE & REEL PACKAGING**

DESCRIPTION

The NE38018 is a low cost gallium arsenide Hetero-Junction FET housed in a miniature (SOT-343) plastic surface mount package. The device is fabricated using ion implantation for improved RF and DC performance, reliability, and uniformity. Its low noise figure, high gain, small size and weight make it an ideal low noise medium power amplifier transistor in the 1-3 GHz frequency range. The NE38018 is suitable for GPS, PCS, WLAN, MMDS, and other commercial applications.

NEC's stringent quality assurance and test procedures ensure the highest reliability and performance.

NOISE FIGURE & ASSOCIATED GAIN vs. FREQUENCY
V_{CE} = 2 V, I_D = 5 mA

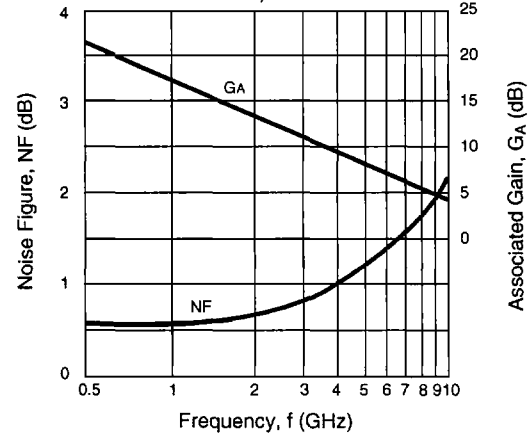

1

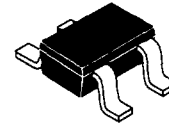

18 Package

SOT-343 Style

ELECTRICAL CHARACTERISTICS (T_A = 25°C)

PART NUMBER PACKAGE OUTLINE			NE38018 18		
SYMBOL	PARAMETERS AND CONDITIONS	UNITS	MIN	TYP	MAX
NF ¹	Noise Figure at V _{DS} = 2 V, I _D = 5 mA, f = 2 GHz	dB		0.55	1.0
GA ¹	Associated Gain at V _{DS} = 2 V, I _D = 5 mA, f = 2 GHz	dB	12.5	14.5	
P _{1dB}	Output Power at 1 dB Gain Compression Point, f = 2 GHz V _{DS} = 2 V, I _{DS} = 10 mA V _{DS} = 3 V, I _{DS} = 30 mA	dBm dBm		13 17 (V67) 18 (V68)	
G _{1dB}	Gain at P _{1dB} , f = 2 GHz V _{DS} = 2 V, I _{DS} = 10 mA V _{DS} = 3 V, I _{DS} = 20 mA	dB dB		16.0 16.5	
MAG	V _{DS} = 2 V, I _{DS} = 5 mA, f = 2 GHz			16.5	
O/P I _{P3}	Output I _{P3} at f = 2 GHz, Δf = 1 MHz, V _{DS} = 3 V, I _{DS} = 5 mA	dBm dBm		22 (V67) 23 (V68)	
I _{DSS}	Saturated Drain Current at V _{DS} = 2 V, V _{GS} = 0 V	mA	40	100	170
V _P	Pinch Off Voltage at V _{DS} = 2 V, I _D = 100 μA	V	-0.1	-0.8	-1.5
g _m	Transconductance at V _{DS} = 2 V, I _D = 5 mA	mS	50	80	
I _{GSO}	Gate to Source Leakage Current at V _{GS} = -3 V	μA		1	20
R _{TH(CH-A)}	Thermal Resistance (Channel to Ambient)	°C/W		833	

Note:

1. Typical values of noise figures and associated gain are those obtained when 50% of the devices from a large number of lots were individually measured in a circuit with the input individually tuned to obtain the minimum value. Maximum values are criteria established on the production line as a "go-no-go" screening test with the fixture tuned for the "generic" type but not for each specimen.

ABSOLUTE MAXIMUM RATINGS¹ (T_A = 25°C)

SYMBOLS	PARAMETERS	UNITS	RATINGS
V _{DS}	Drain to Source Voltage	V	4
I _G	Gate Current	μA	100
V _{GSO}	Gate to Source Voltage	V	-3
I _{DS}	Drain Current	mA	I _{DSS}
T _{CH}	Channel Temperature	°C	125
T _{STG}	Storage Temperature	°C	-65 to +125
P _T	Total Power Dissipation	mW	150

Note:

1. Operation in excess of any one of these parameters may result in permanent damage.

RECOMMENDED OPERATING CONDITIONS (T_A = 25°C)

SYMBOLS	PARAMETERS	UNITS	MIN	TYP	MAX
V _{DS}	Drain to Source Voltage	V	1	2	3
I _D	Drain Current	mA	2	5	30
P _{in}	Input Power	dBm			0

TYPICAL NOISE PARAMETERS (T_A = 25°C)

FREQ. (GHz)	NF _{OPT} (dB)	G _A (dB)	Γ _{OPT}		R _n /50
			MAG	ANG	
V_{DS} = 2 V, I_{DS} = 5 mA					
0.9	0.41	21.1	0.65	25.1	0.18
1.0	0.42	20.3	0.63	27.2	0.18
1.5	0.48	16.9	0.55	42.4	0.17
1.9	0.54	15.0	0.48	58.0	0.16
2.0	0.55	14.7	0.46	62.1	0.15
2.5	0.62	13.4	0.38	81.3	0.13
V_{DS} = 2 V, I_{DS} = 10 mA					
0.9	0.37	22.0	0.59	29.2	0.13
1.0	0.38	21.8	0.50	38.0	0.12
1.5	0.44	17.6	0.50	39.6	0.12
1.9	0.49	15.6	0.38	45.1	0.11
2.0	0.50	15.5	0.39	54.4	0.11
2.5	0.56	13.9	0.38	70.3	0.10
V_{DS} = 3 V, I_{DS} = 5 mA					
0.9	0.41	21.8	0.67	24.9	0.18
1.0	0.42	20.8	0.65	26.9	0.18
1.5	0.48	16.9	0.54	42.1	0.17
1.9	0.54	14.8	0.47	57.8	0.16
2.0	0.55	14.4	0.45	61.8	0.15
2.5	0.62	13.3	0.38	80.7	0.13

TYPICAL PERFORMANCE CURVES (T_A = 25°C)

NOISE FIGURE & ASSOCIATED GAIN vs. DRAIN CURRENT

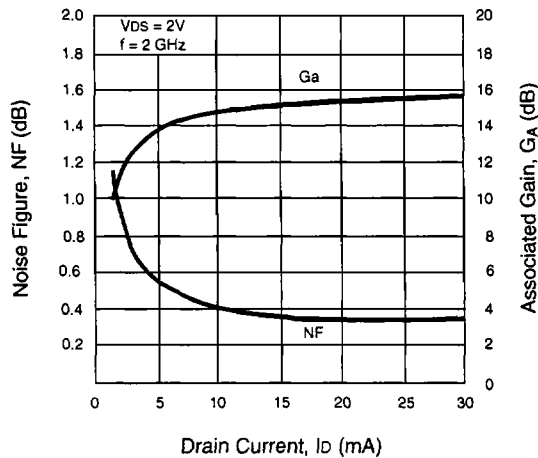

TOTAL POWER DISSIPATION vs. AMBIENT TEMPERATURE

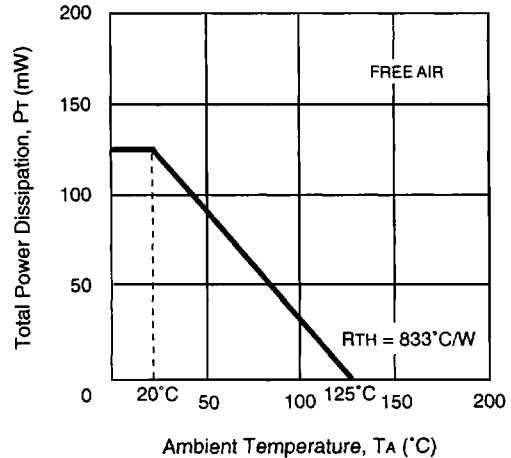

TYPICAL PERFORMANCE CURVES ($T_A = 25^\circ\text{C}$)

DC PERFORMANCE

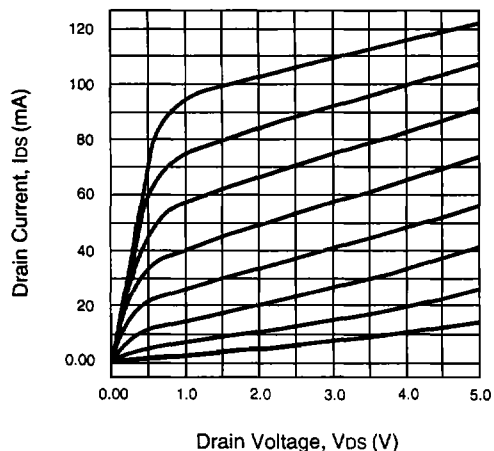

DRAIN CURRENT AND TRANSCONDUCTANCE vs. GATE TO SOURCE VOLTAGE

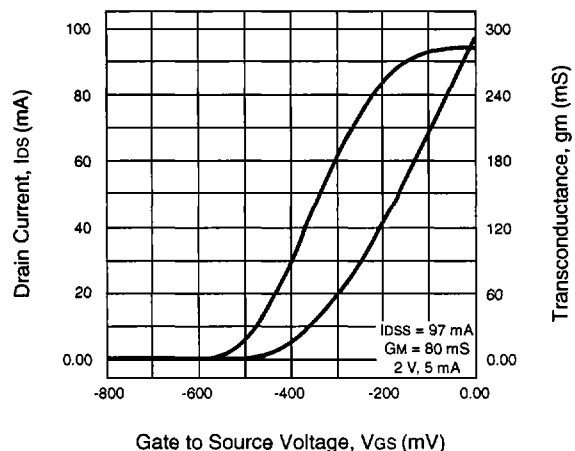

OUTPUT POWER, GAIN AND POWER ADDED EFFICIENCY vs. INPUT POWER
 $V_{DS} = 3 \text{ V}, I_{DS} = 20 \text{ mA}, f = 2 \text{ GHz}$

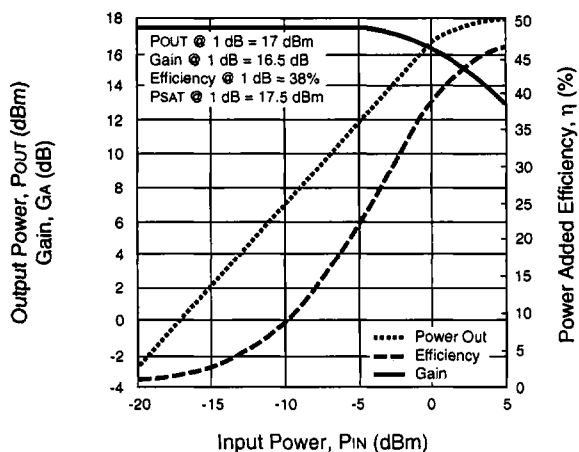

OUTPUT POWER AND INTERMODULATION PRODUCTS vs. INPUT POWER
 $V_{DS} = 3 \text{ V}, I_{DS} = 20 \text{ mA}, f = 2 \text{ GHz}$

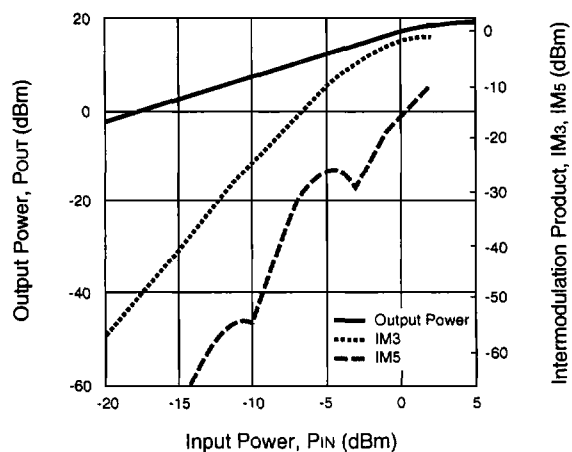

TYPICAL SCATTERING PARAMETERS (T_A = 25°C)

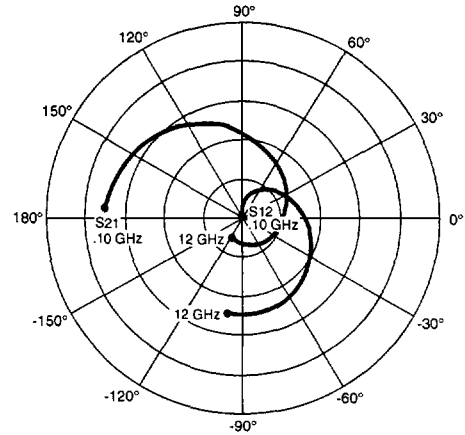
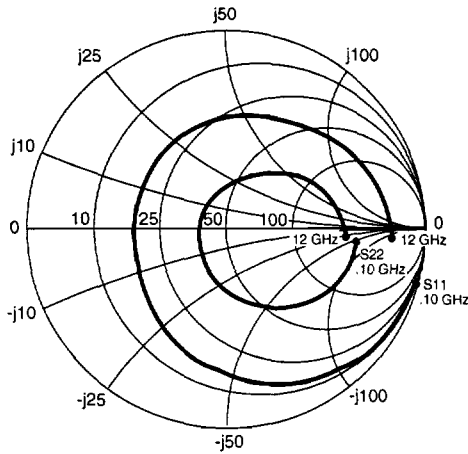

V_{ds} = 2 V, I_{ds} = 5 mA

FREQUENCY (GHz)	S ₁₁		S ₂₁		S ₁₂		S ₂₂		K	MAG ¹ (dB)
	MAG	ANG	MAG	ANG	MAG	ANG	MAG	ANG		
0.10	0.992	-2.50	6.847	175.44	0.009	86.79	0.642	-7.96	0.05	28.63
0.20	1.027	-10.20	6.717	171.01	0.017	84.51	0.626	-11.36	-0.16	25.95
0.30	0.999	-17.98	6.698	165.35	0.025	79.74	0.632	-13.98	0.00	24.23
0.40	0.981	-24.47	6.640	160.28	0.033	76.53	0.632	-17.71	0.06	22.99
0.50	0.964	-29.81	6.518	154.91	0.041	72.59	0.623	-21.83	0.12	22.03
1.00	0.876	-56.41	5.830	131.52	0.073	56.83	0.561	-40.01	0.28	19.04
1.50	0.773	-79.57	5.119	111.75	0.096	44.71	0.493	-54.94	0.42	17.28
2.00	0.686	-100.40	4.506	94.58	0.114	35.02	0.430	-67.65	0.54	16.01
2.50	0.604	-120.28	4.005	78.97	0.127	26.80	0.370	-79.24	0.67	15.02
3.00	0.542	-140.30	3.590	64.57	0.138	19.51	0.314	-90.98	0.77	14.18
3.50	0.496	-160.84	3.239	50.93	0.147	12.72	0.263	-103.80	0.87	13.45
4.00	0.472	178.65	2.941	38.00	0.155	6.47	0.219	-118.63	0.94	12.80
5.00	0.476	141.84	2.464	13.65	0.169	-5.34	0.167	-156.15	1.04	10.46
6.00	0.506	112.81	2.109	-8.88	0.183	-16.40	0.154	164.89	1.09	8.79
7.00	0.548	87.17	1.833	-30.86	0.199	-28.79	0.161	124.93	1.11	7.60
8.00	0.603	62.70	1.600	-52.62	0.212	-42.18	0.207	82.05	1.13	6.59
9.00	0.677	40.36	1.382	-74.07	0.223	-56.42	0.307	53.73	1.10	6.03
10.00	0.750	21.52	1.184	-94.38	0.229	-71.03	0.422	35.57	1.03	6.04
11.00	0.800	5.69	1.011	-113.63	0.231	-85.60	0.511	19.76	0.98	6.43
12.00	0.829	-9.17	0.873	-132.22	0.232	-100.40	0.571	2.76	0.95	5.78

Note:

1. Gain Calculations:

$$MAG = \frac{|S_{21}|}{|S_{12}|} \left(K \pm \sqrt{K^2 - 1} \right). \text{ When } K \leq 1, \text{ MAG is undefined and MSG values are used. } MSG = \frac{|S_{21}|}{|S_{12}|}, K = \frac{1 + |\Delta|^2 - |S_{11}|^2 - |S_{22}|^2}{2 |S_{12}| |S_{21}|}, \Delta = S_{11} S_{22} - S_{21} S_{12}$$

MAG = Maximum Available Gain

MSG = Maximum Stable Gain

TYPICAL SCATTERING PARAMETERS (TA = 25°C)

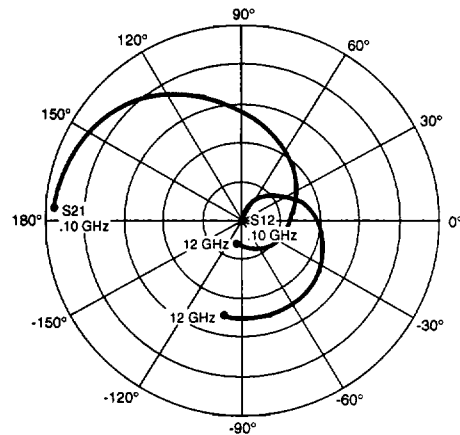
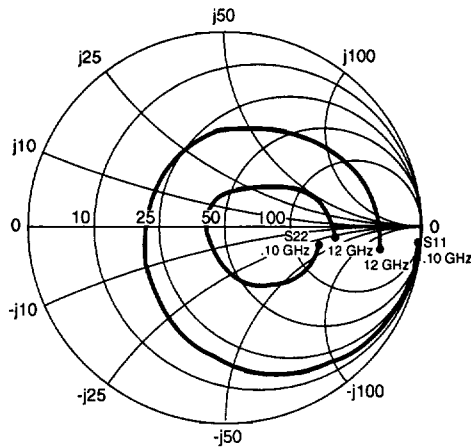

Vds = 2 V, Ids = 10 mA

FREQUENCY (GHz)	S11		S21		S12		S22		K	MAG ¹ (dB)
	MAG	ANG	MAG	ANG	MAG	ANG	MAG	ANG		
0.10	0.992	-3.80	9.822	174.93	0.008	87.39	0.487	-9.73	0.06	30.8
0.20	1.000	-12.31	9.639	169.20	0.015	84.00	0.477	-13.87	-0.14	28.1
0.30	0.991	-21.04	9.541	162.65	0.022	80.28	0.477	-17.02	0.05	26.4
0.40	0.967	-28.50	9.383	156.82	0.029	76.20	0.475	-21.39	0.12	25.1
0.50	0.943	-34.68	9.134	150.85	0.035	72.64	0.464	-25.94	0.19	24.1
1.00	0.815	-63.96	7.764	125.49	0.063	58.52	0.397	-45.59	0.40	20.9
1.50	0.689	-88.19	6.502	105.45	0.083	48.85	0.334	-60.27	0.58	19.0
2.00	0.593	-109.25	5.522	88.71	0.100	41.27	0.280	-72.14	0.71	17.4
2.50	0.513	-129.18	4.772	73.87	0.115	34.71	0.231	-83.06	0.82	16.2
3.00	0.458	-149.33	4.188	60.34	0.129	28.25	0.187	-95.23	0.90	15.1
3.50	0.423	-169.94	3.722	47.65	0.143	21.92	0.147	-110.79	0.96	14.2
4.00	0.410	169.75	3.343	35.63	0.155	15.50	0.116	-132.15	1.00	13.0
5.00	0.433	134.29	2.765	12.86	0.179	2.21	0.102	170.07	1.05	10.6
6.00	0.472	106.93	2.350	-8.50	0.200	-11.13	0.128	127.00	1.07	9.1
7.00	0.520	82.83	2.035	-29.55	0.219	-25.78	0.167	91.67	1.08	8.0
8.00	0.579	59.50	1.769	-50.43	0.232	-41.12	0.239	59.52	1.09	7.0
9.00	0.659	38.07	1.529	-70.98	0.241	-56.67	0.342	38.95	1.07	6.4
10.00	0.734	19.78	1.317	-90.40	0.244	-72.00	0.445	24.63	1.03	6.3
11.00	0.785	4.28	1.139	-109.06	0.243	-87.00	0.520	10.69	0.99	6.7
12.00	0.814	-10.33	1.000	-127.38	0.242	-102.03	0.567	-5.07	0.98	6.2

Note:

1. Gain Calculations:

$$MAG = \frac{|S_{21}|}{|S_{12}|} (K \pm \sqrt{K^2 - 1})$$

When $K \leq 1$, MAG is undefined and MSG values are used. $MSG = \frac{|S_{21}|}{|S_{12}|}$, $K = \frac{1 + |\Delta|^2 - |S_{11}|^2 - |S_{22}|^2}{2 |S_{12}| |S_{21}|}$, $\Delta = S_{11} S_{22} - S_{21} S_{12}$

MAG = Maximum Available Gain
MSG = Maximum Stable Gain

TYPICAL SCATTERING PARAMETERS (T_A = 25°C)

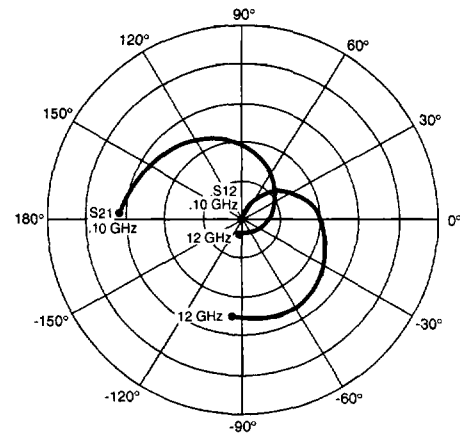
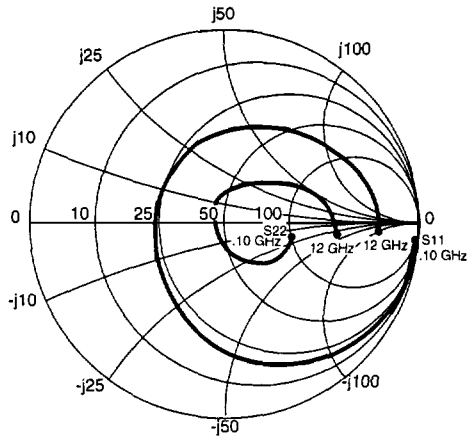

V_{DS} = 2 V, I_{DS} = 20 mA

FREQUENCY (GHz)	S ₁₁		S ₂₁		S ₁₂		S ₂₂		K	MAG ¹ (dB)
	MAG	ANG	MAG	ANG	MAG	ANG	MAG	ANG		
0.10	0.992	-5.06	12.743	174.22	0.007	88.57	0.344	-11.92	0.08	32.62
0.20	1.000	-14.26	12.486	167.43	0.013	84.68	0.338	-16.65	-0.11	29.75
0.30	0.982	-23.84	12.265	160.10	0.019	80.49	0.335	-19.97	0.10	28.00
0.40	0.952	-32.12	11.944	153.54	0.025	77.09	0.332	-24.86	0.19	26.70
0.50	0.918	-38.97	11.531	147.07	0.031	73.91	0.321	-29.61	0.27	25.68
1.00	0.758	-70.06	9.340	120.51	0.055	62.14	0.263	-49.67	0.53	22.29
1.50	0.620	-94.61	7.527	100.66	0.074	54.30	0.213	-63.22	0.71	20.04
2.00	0.523	-115.52	6.235	84.55	0.093	47.65	0.173	-73.71	0.83	18.27
2.50	0.448	-135.35	5.294	70.45	0.110	41.25	0.138	-83.99	0.91	16.81
3.00	0.400	-155.49	4.587	57.62	0.127	34.62	0.105	-97.82	0.96	15.57
3.50	0.375	-176.15	4.045	45.60	0.144	27.79	0.075	-121.02	1.00	14.50
4.00	0.370	163.70	3.611	34.20	0.159	20.78	0.060	-159.78	1.02	12.66
5.00	0.405	129.39	2.967	12.46	0.187	6.21	0.097	134.07	1.04	10.77
6.00	0.449	103.27	2.513	-8.15	0.211	-8.47	0.145	103.25	1.05	9.40
7.00	0.501	80.15	2.170	-28.58	0.231	-24.24	0.196	75.95	1.05	8.29
8.00	0.564	57.58	1.882	-48.89	0.245	-40.53	0.276	49.96	1.06	7.33
9.00	0.647	36.64	1.625	-68.85	0.251	-56.68	0.376	32.15	1.05	6.73
10.00	0.724	18.68	1.402	-87.73	0.253	-72.41	0.473	19.01	1.02	6.49
11.00	0.776	3.43	1.220	-105.84	0.250	-87.59	0.541	5.58	1.00	6.65
12.00	0.805	-11.10	1.081	-123.82	0.248	-102.80	0.581	-9.91	0.99	6.39

Note:

1. Gain Calculations:

$$MAG = \frac{|S_{21}|}{|S_{12}|} (K \pm \sqrt{K^2 - 1}). \text{ When } K \leq 1, \text{ MAG is undefined and MSG values are used. } MSG = \frac{|S_{21}|}{|S_{12}|}, K = \frac{1 + |\Delta|^2 - |S_{11}|^2 - |S_{22}|^2}{2 |S_{12}| |S_{21}|}, \Delta = S_{11} S_{22} - S_{21} S_{12}$$

MAG = Maximum Available Gain

MSG = Maximum Stable Gain

TYPICAL SCATTERING PARAMETERS (T_A = 25 °C)

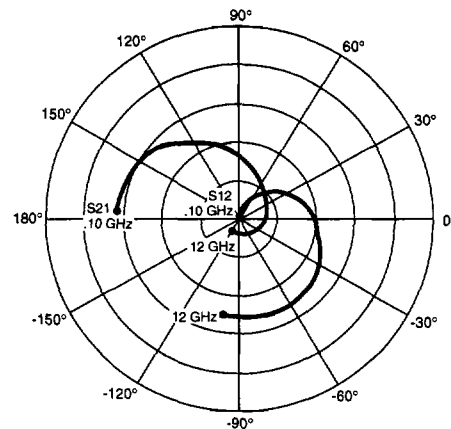
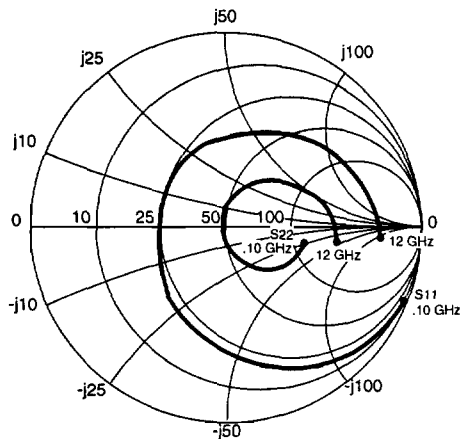

V_{DS} = 3 V, I_{DS} = 20 mA

FREQUENCY (GHz)	S ₁₁		S ₂₁		S ₁₂		S ₂₂		K	MAG ¹ (dB)
	MAG	ANG	MAG	ANG	MAG	ANG	MAG	ANG		
0.10	0.991	-4.94	12.631	174.25	0.007	87.26	0.378	-11.30	0.07	32.84
0.20	1.000	-14.12	12.376	167.54	0.013	83.63	0.371	-15.83	-0.10	29.78
0.30	0.982	-23.65	12.164	160.26	0.019	80.29	0.369	-19.06	0.10	27.99
0.40	0.953	-31.83	11.856	153.75	0.025	77.02	0.365	-23.73	0.19	26.69
0.50	0.920	-38.63	11.451	147.30	0.031	73.59	0.354	-28.39	0.27	25.68
1.00	0.761	-69.55	9.300	120.79	0.055	61.65	0.291	-47.62	0.52	22.32
1.50	0.623	-93.97	7.511	100.94	0.074	53.68	0.239	-60.59	0.70	20.08
2.00	0.525	-114.82	6.229	84.81	0.091	47.11	0.196	-70.43	0.82	18.34
2.50	0.450	-134.56	5.295	70.69	0.108	40.91	0.160	-79.67	0.91	16.89
3.00	0.401	-154.62	4.593	57.84	0.125	34.43	0.125	-91.32	0.96	15.66
3.50	0.374	-175.27	4.052	45.81	0.140	27.75	0.091	-109.07	1.00	14.60
4.00	0.369	164.59	3.620	34.39	0.155	20.95	0.067	-139.28	1.02	12.72
5.00	0.402	130.10	2.979	12.59	0.183	6.58	0.082	146.70	1.04	10.84
6.00	0.446	103.91	2.527	-8.08	0.207	-7.79	0.126	109.81	1.05	9.48
7.00	0.498	80.73	2.185	-28.56	0.227	-23.38	0.174	79.83	1.06	8.38
8.00	0.561	58.12	1.899	-48.95	0.241	-39.52	0.253	52.19	1.06	7.42
9.00	0.645	37.13	1.643	-69.05	0.249	-55.59	0.355	33.99	1.05	6.84
10.00	0.723	19.17	1.419	-88.12	0.251	-71.31	0.455	20.78	1.02	6.66
11.00	0.776	3.81	1.234	-106.45	0.249	-86.55	0.526	7.29	0.99	6.95
12.00	0.806	-10.76	1.091	-124.65	0.248	-101.85	0.569	-8.23	0.98	6.44

Note:

1. Gain Calculations:

$$MAG = \frac{|S_{21}|}{|S_{12}|} \left(K \pm \sqrt{K^2 - 1} \right). \text{ When } K \leq 1, \text{ MAG is undefined and MSG values are used. } MSG = \frac{|S_{21}|}{|S_{12}|}, K = \frac{1 + |\Delta|^2 - |S_{11}|^2 - |S_{22}|^2}{2 |S_{12}| |S_{21}|}, \Delta = S_{11} S_{22} - S_{21} S_{12}$$

MAG = Maximum Available Gain

MSG = Maximum Stable Gain

NE38018 NONLINEAR MODEL

SCHMATIC

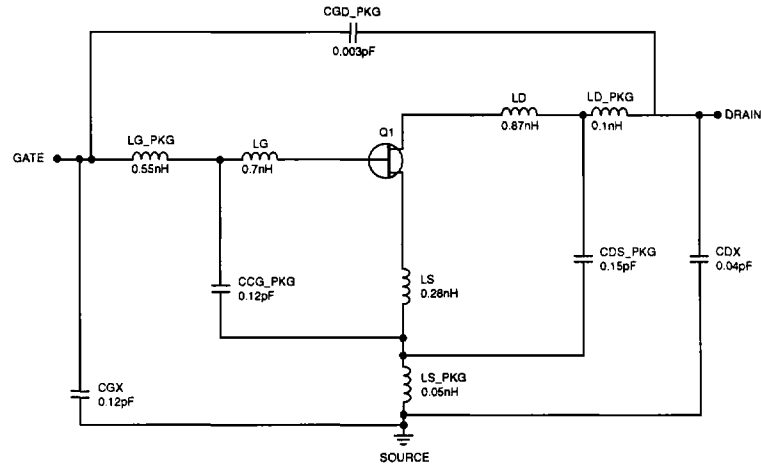

FET NONLINEAR MODEL PARAMETERS (1)

Parameters	Q1	Parameters	Q1
VTO	-0.5935	RG	2.5
VTOSC	0	RD	3
ALPHA	7	RS	1.5
BETA	1.14	RGMET	0
GAMMA	0.044	KF	0
GAMMADC	0.03	AF	1
Q	3.5	TNOM	27
DELTA	0	XTI	3
VBI	0.8	EG	1.43
IS	1e-14	VTOTC	0
N	1.3	BETATCE	0
RIS	2.3	FFE	1
RID	2.3		
TAU	1e-12		
CDS	0.1e-12		
RDB	5000		
CBS	1e-11		
CGSO	1.2e-12		
CGDO	0.145e-12		
DELTA 1	0.3		
DELTA 2	0.2		
FC	0.5		
VBR	Infinity		

UNITS

Parameter	Units
time	seconds
capacitance	farads
inductance	henries
resistance	ohms
voltage	volts
current	amps

MODEL RANGE

Frequency: 0.5 to 12 GHz
 Bias: $V_{DS} = 2\text{ V to } 3\text{ V}$, $I_D = 10\text{ mA to } 40\text{ mA}$
 $I_{DSS} = 97\text{ mA @ } V_{GS} = 0\text{ V}$, $V_{DS} = 2\text{ V}$
 Power: $V_{DS} = 2\text{ V}$, $I_D = 20\text{ mA}$, 2 GHz
 Date: 4/98

(1) Series IV Libra TOM Model

OUTLINE DIMENSIONS (Units in mm)

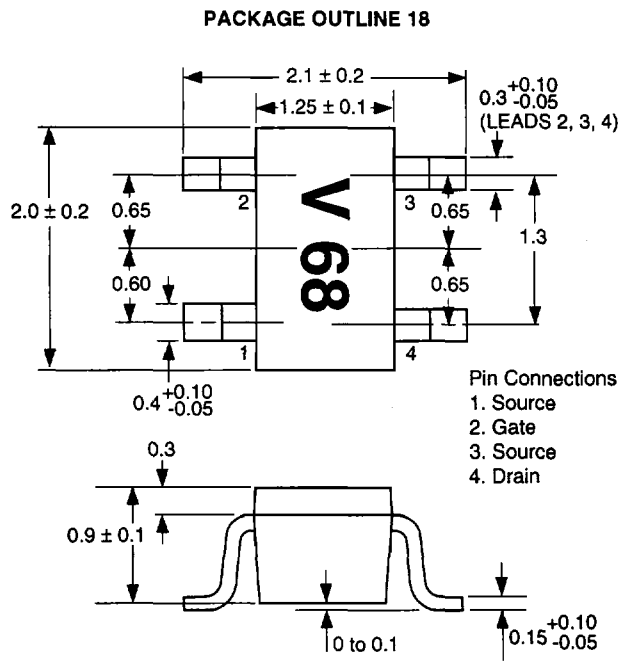

ORDERING INFORMATION

PART NUMBER	QTY	I _{DSS} RANGE (mA)	MARKING
NE38018	Bulk up to 3 K	40-165	V67 or V68
NE38018-TI-67	3 K/Reel	40-90	V67
NE38018-TI-68	3 K/Reel	70-170	V68

