

1 Overview

1.1 Features

Stereo Sound Processing

- Four stereo AF inputs
- Input/Output interface for external equalizer
- Max. gain switchable between 0 dB and 6 dB
- Bass and treble control
- Four independent attenuators for volume balance and fader control

Control Part

- I²C Bus interface compatible for standard and fast mode
- Control of sound processing

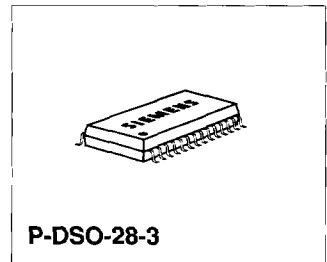

Type	Ordering Code	Package
TDA 4390-2X	Q67000-A5183	P-DSO-28-3

1.2 Application

The TDA 4390-2X is a single-chip audio sound system. The circuit can be partitioned into two functional blocks: stereo sound processing and control part.

1.3 Pin Configuration
(top view)

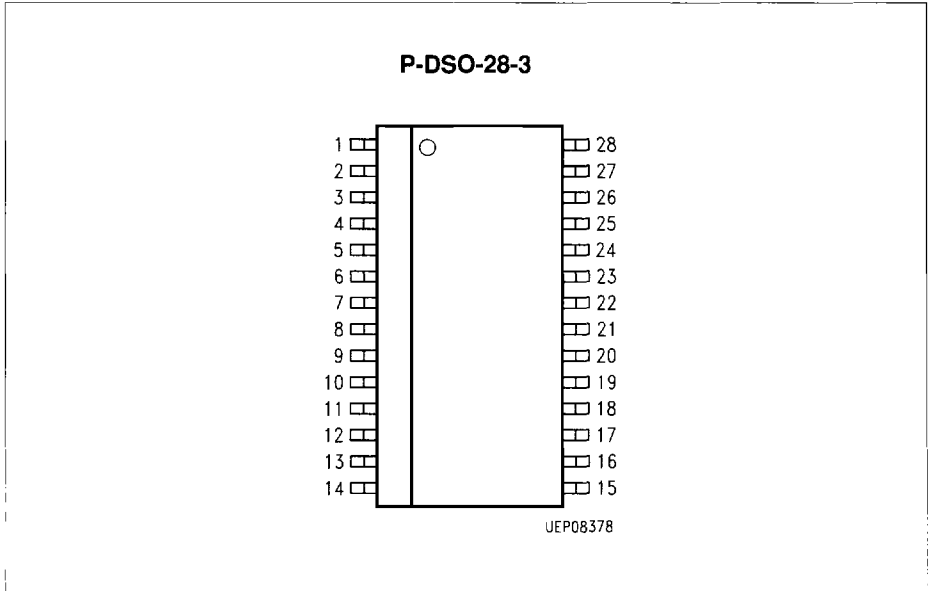

Figure 1

1.4 Pin Definitions and Functions

Pin No.	Function
1	AF input 1 left
2	AF input 2 left
3	AF input 3 left
4	AF input 3 left
5	AF output switch left
6	AF input tone control volume left
7	Reset (all functions in power ON status)
8	I ² C Bus SCL
9	I ² C Bus SDA
10	Supply voltage
11	Corner frequency treble left
12	Corner frequency treble right
13	AF output right front
14	AF output right rear
15	AF output left rear
16	AF output left front
17	Corner frequency bass right output
18	Corner frequency bass right input
19	Corner frequency bass left output
20	Corner frequency bass left input
21	Ground
22	Blocking AF operating point
23	AF input tone control volume right
24	AF output switch right
25	AF input 4 right
26	AF input 3 right
27	AF input 2 right
28	AF input 1 right

1.4.1 Pin Description

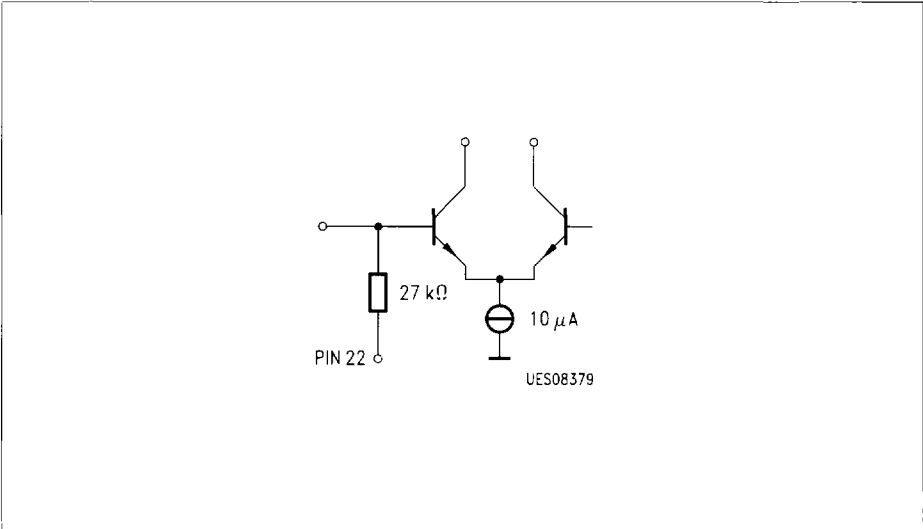

Figure 2
AF Inputs PIN 1/2/3/4/6/23/25/26/27/28

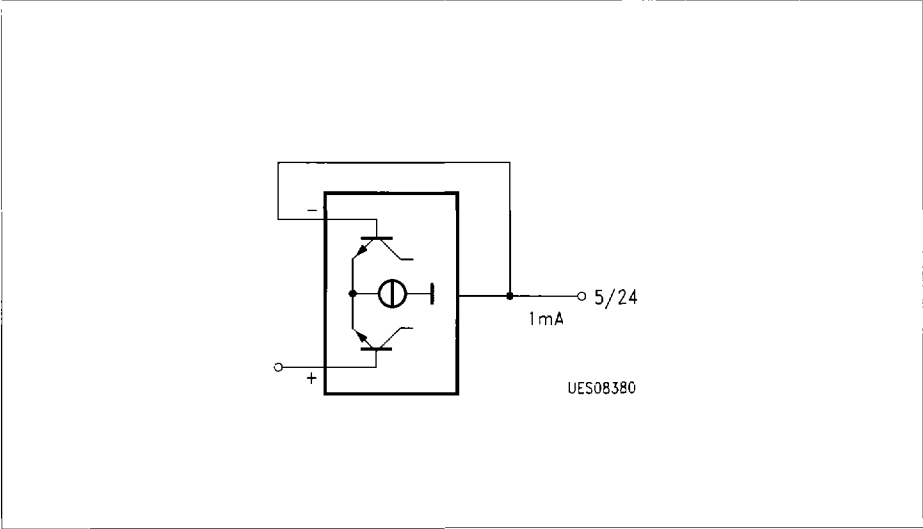

Figure 3
AF Outputs PIN 5/24

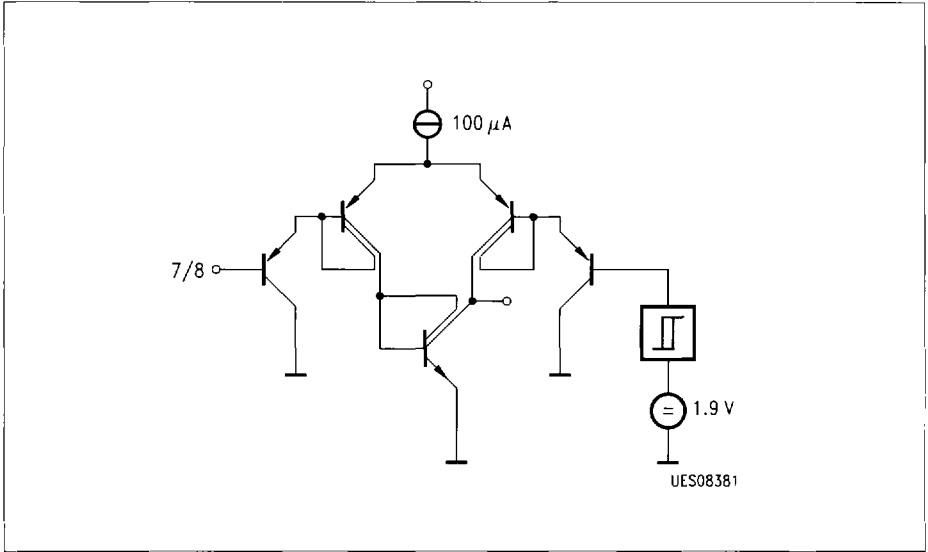

Figure 4
Reset PIN 7, I²C Bus SCL PIN 8

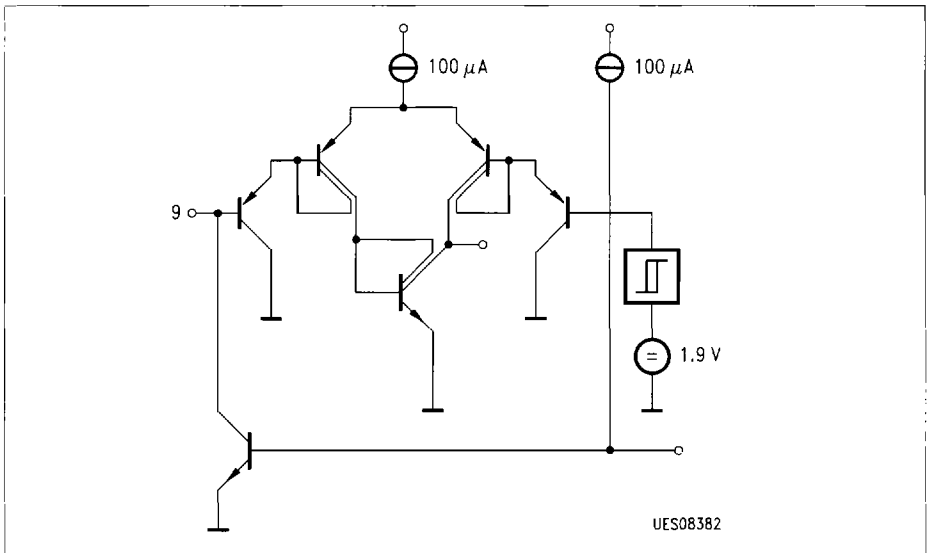

Figure 5
I²C Bus SDA PIN 9

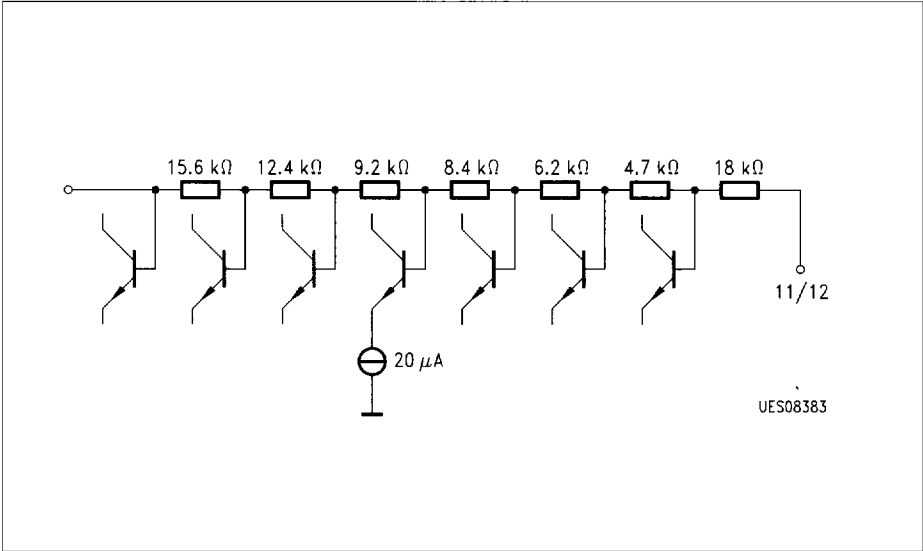

Figure 6
Corner Frequency Treble PIN 11/12

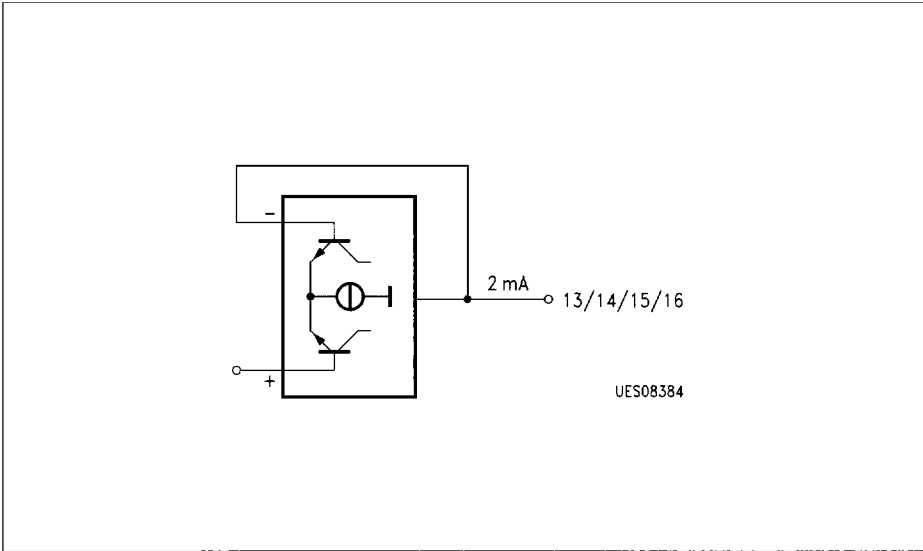

Figure 7
AF Outputs PIN 13/14/15/16

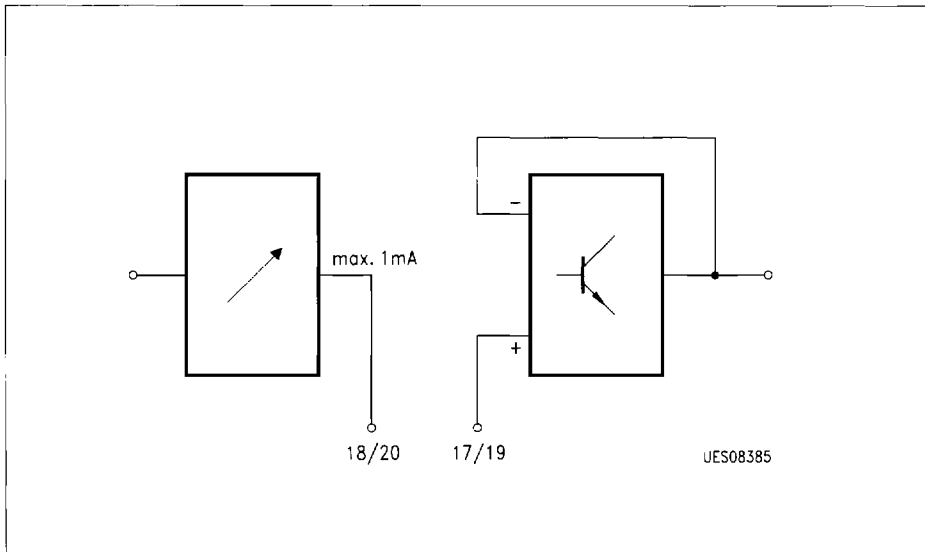

Figure 8
Corner Frequency Bass PIN 17/18/19/20

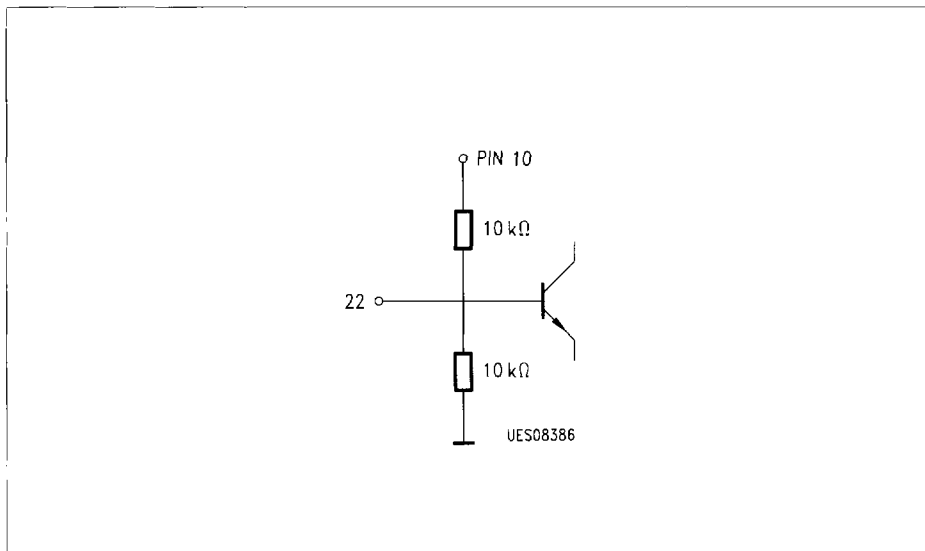

Figure 9
AF Operating Point PIN 22

1.5 Functional Block Diagram

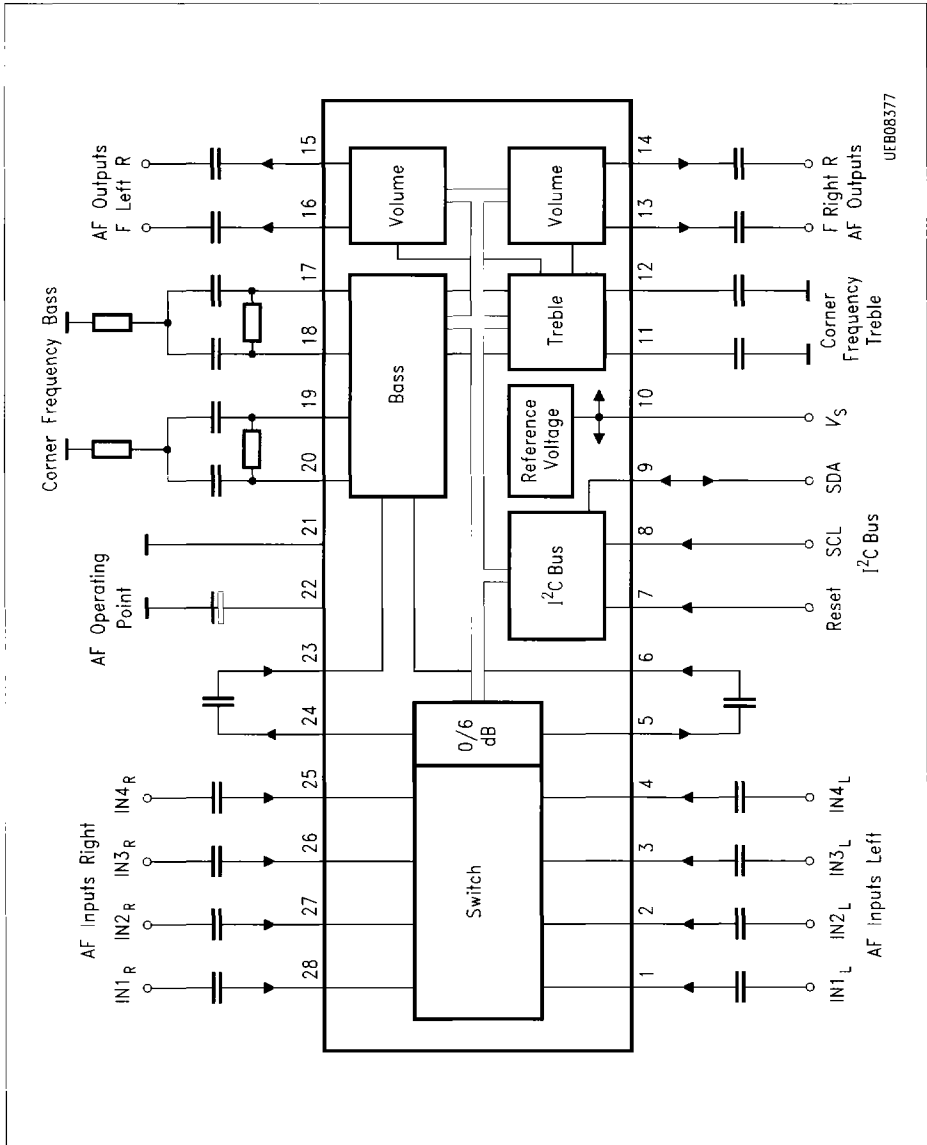

Figure 10
Block Diagram

2 Circuit Description

2.1 Signal Processing

1. The selection of the AF inputs happens in the input switch. There are four stereo inputs available. An input level switch circuitry behind the input switch realizes the adaption of different signal source levels. A gain of 0 dB or 6 dB is possible. After this section a stereo output/input is placed for connecting external circuits like an equalizer.
2. In the following signalpath there is tone control, consisting of bass and treble control. Bass control offers a control range of + 18 dB to – 12 dB with a stepwidth of 2 dB. Frequency characteristic, 1st order or 2nd order (resonance type) is fixed by external components. Treble control offers a control range of ± 12 dB with a stepwidth of 2 dB. The treble control corner frequency is fixed by an external capacitor. Last stage in signalpath is volume control which can be adjusted independent for left, right, rear and front. 57 steps with an increment of 1.25 dB give a setting range of 70 dB, the 57th step activates muting.

2.2 Controlpart

All functions are controlled via an I²C Bus interface. All data is stored into a latch circuit. The telegram structure is built as follows:

Startcondition – chipaddress – any number of databytes – stopcondition.

For the databytes the following conditions must be fulfilled:

Before transmitting a databyte a subaddress byte must *first* be placed in the data telegram.

2.2.1 Chipaddress

MSB					LSB		
1	0	0	0	0	0	1	0

2.2.2 Subaddress Bytes

	MSB					LSB		
Volume front left	x	x	x	x	x	0	0	0
Volume front right	x	x	x	x	x	0	0	1
Volume rear left	x	x	x	x	x	0	1	0
Volume rear right	x	x	x	x	x	0	1	1
Bass/treble	x	x	x	x	x	1	0	1
Switchbyte	x	x	x	x	x	1	1	1

2.2.3 Controlbytes

a) Volume left, right, front, rear

	MSB					LSB		
Max. volume	x	x	1	1	1	1	1	1
Max-1	x	x	1	1	1	1	1	0

Max-16	x	x	1	1	0	0	0	0
--------	---	---	---	---	---	---	---	---

Max-55	x	x	0	0	1	0	0	0
MUTE	x	x	0	0	0	1	1	1
MUTE	x	x	0	0	0	0	0	0
MUTE	x	x	0	0	0	x	x	x
Power ON	0	0	0	0	0	0	0	1

b) Treble/Bass

	MSB				LSB			
Linear	1	0	0	0	1	0	0	1
Max. treble, lin. bass	0	0	1	0	1	0	0	1
Max. treble, lin. bass	0	0	0	×	1	0	0	1
Min. treble, lin. bass	1	1	1	0	1	0	0	1
Min. treble, lin. bass	1	1	1	×	1	0	0	1
Lin. treble, max. bass	1	0	0	0	0	0	0	0
Lin. treble, min. bass	1	0	0	0	1	1	1	1
Max. treble, max. bass	0	0	0	×	0	0	0	0
Min. treble, min. bass	1	1	1	×	1	1	1	1
Power ON	0	0	0	0	0	0	0	1

MSB
LSB
MSB
LSB
treble
treble
bass
bass

c) Switchbyte

MSB					LSB		
MUTE	IN1	IN2	IN3	IN4	Gain	×	×
MUTE = 0	MUTE OFF; power ON						
MUTE = 1	MUTE ON						
IN1 = 0	Input1 OFF; power ON						
IN1 = 1	Input1 ON						
IN2 = 0	Input1 OFF; power ON						
IN2 = 1	Input1 ON						
IN3 = 0	Input1 OFF; power ON						
IN3 = 1	Input1 ON						
IN4 = 0	Input1 OFF; power ON						
IN4 = 1	Input1 ON						
Gain = 0	Gain 0 dB; power ON						
Gain = 1	Gain 6 dB						

If no signal is activated, this is interpreted as muting.
There is no mutual lockout of the inputs for multiple selections.

3 Electrical Characteristics

3.1 Absolute Maximum Ratings

$T_A = -40\text{ °C to }85\text{ °C}$

Parameter	Symbol	Limit Values		Unit	Remarks
		min.	max.		
Supply voltage	V_{10}	0	14	V	
Max. DC voltage	V_1	0	V_{10}	V	
Max. DC voltage	V_2	0	V_{10}	V	
Max. DC voltage	V_3	0	V_{10}	V	
Max. DC voltage	V_4	0	V_{10}	V	
Max. DC voltage	V_6	0	V_{10}	V	
Max. DC voltage	V_7	0	V_{10}	V	
Max. DC voltage	V_8	0	6	V	
Max. DC voltage	V_{11}	0	V_{10}	V	
Max. DC voltage	V_{12}	0	V_{10}	V	
Max. DC voltage	V_{18}	0	V_{10}	V	
Max. DC voltage	V_{20}	0	V_{10}	V	
Max. DC voltage	V_{22}	0	V_{10}	V	
Max. DC voltage	V_{23}	0	V_{10}	V	
Max. DC voltage	V_{25}	0	V_{10}	V	
Max. DC voltage	V_{26}	0	V_{10}	V	
Max. DC voltage	V_{27}	0	V_{10}	V	
Max. DC voltage	V_{28}	0	V_{10}	V	
Max. DC current	I_5	0	2	mA	
Max. DC current	I_9	0	2	mA	
Max. DC current	I_{13}	0	2	mA	
Max. DC current	I_{14}	0	2	mA	

3.1 Absolute Maximum Ratings (cont'd)

$T_A = -40\text{ °C to }85\text{ °C}$

Parameter	Symbol	Limit Values		Unit	Remarks
		min.	max.		
Max. DC current	I_{15}	0	2	mA	
Max. DC current	I_{16}	0	2	mA	
Max. DC current	I_{17}	0	2	mA	
Max. DC current	I_{19}	0	2	mA	
Max. DC current	I_{24}	0	2	mA	
Junction temperature	T_J		150	°C	
Storage temperature	T_S	-40	125	°C	
Thermal resistance	R_{thSA}		76	K/W	

Note: Maximum ratings are absolute ratings; exceeding only one of these values may cause irreversible damage to the integrated circuit.

3.2 Operating Range

Parameter	Symbol	Limit Values		Unit
		min.	max.	
Supply voltage	V_S	7.5	13.2	V
Ambient temperature range	T_A	-40	85	°C
Input frequency range	f_i	0.01	20	kHz

Note: In the operating range the functions given in the circuit description are fulfilled.

3.3 AC/DC Characteristics

$V_S = 10\text{ V}$, $T_A = -40\text{ °C}$ to 85 °C

Parameter	Symbol	Limit Values			Unit	Test Condition	Test Circuit
		min.	typ.	max.			

AF reference level $0\text{ dB} = 150\text{ mV}$, $f_i = 1\text{ kHz}$, if not stated otherwise.

I²C Bus preset: Start – 82 – 00, 3F – 01, 3F – 02, 3F – 03, 3F – 05. 89 – 07, 40 – Stop
 Chipaddr. – Vol 63 – Vol 63 – Vol 63 – tone lin – IN1

The basic setting for each point in the specification is always preset; only settings which deviate from this, are given in the test conditions. Details in *italics* only provide explanation of the hexadecimal code and which switch bits on the setbytes are stated.

Current consumption	I_{10}		39	55	mA		1
---------------------	----------	--	----	----	----	--	---

A. Signal Section

Gain ¹⁾	V_{5-1}	-1	0	1	dB		1
Gain ¹⁾	V_{24-28}	-1	0	1	dB		1
Gain ¹⁾	V_{5-1}	5	6	7	dB	07, 44; <i>gain = 6 dB</i>	1
Gain ¹⁾	V_{24-28}	5	6	7	dB	07, 44; <i>gain = 6 dB</i>	1
Max. gain	V_{15-6}	-2	0	2	dB		1
Max. gain	V_{16-6}	-2	0	2	dB		1
Max. gain	V_{13-23}	-2	0	2	dB		1
Max. gain	V_{14-23}	-2	0	2	dB		1
Min. gain	V_{15-6}		-70	-60	dB	00, 08-02, 08; <i>Vol 8</i>	1
Min. gain	V_{16-6}		-70	-60	dB	00, 08-02, 08; <i>Vol 8</i>	1
Min. gain	V_{13-23}		-70	-60	dB	01, 08-03, 08; <i>Vol 8</i>	1
Min. gain	V_{14-23}		-70	-60	dB	01, 08-03, 08; <i>Vol 8</i>	1
Tracking error	ΔV_{13-14}			±3	dB	01, 3F to 01, 24 03, 3F to 03, 24; <i>Vol 63-36</i>	1
Tracking error	ΔV_{15-16}			±3	dB	00, 3F to 00, 24 02, 3F to 02, 24; <i>Vol 63-36</i>	1
Tracking error	ΔV_{13-16}			±3	dB	00, 3F to 00, 24 01, 3F to 01, 24; <i>Vol 63-36</i>	1
Tracking error	ΔV_{14-15}			±3	dB	02, 3F to 02, 24 03, 3F to 03, 24; <i>Vol 63-36</i>	1

¹⁾ Same values apply for feeding in on pins 2 ... 4, and 25 ... 27.

3.3 AC/DC Characteristics (cont'd)

$V_S = 10\text{ V}$, $T_A = -40\text{ }^\circ\text{C}$ to $85\text{ }^\circ\text{C}$

Parameter	Symbol	Limit Values			Unit	Test Condition	Test Circuit
		min.	typ.	max.			
Step width Vol ₁₃	ΔV_{13}	0	1.25	2.5	dB	01. X-01, (X ± 1) Vol X-Vol (X ± 1)	1
Step width Vol ₁₄	ΔV_{14}	0	1.25	2.5	dB	03. X-03, (X ± 1) Vol X-Vol (X ± 1)	1
Step width Vol ₁₅	ΔV_{15}	0	1.25	2.5	dB	02. X-02, (X ± 1) Vol X-Vol (X ± 1)	1
Step width Vol ₁₆	ΔV_{16}	0	1.25	2.5	dB	02. X-02, (X ± 1) Vol X-Vol (X ± 1)	1
Bass boost	$V_{15.6}$	15	18		dB	05, 80; $f_i = 40\text{ Hz}$ <i>bass max, treble lin</i>	1
Bass boost	$V_{16.6}$	15	18		dB	05, 80; $f_i = 40\text{ Hz}$ <i>bass max, treble lin</i>	1
Bass boost	$V_{13.23}$	15	18		dB	05, 80; $f_i = 40\text{ Hz}$ <i>bass max, treble lin</i>	1
Bass boost	$V_{14.23}$	15	18		dB	05, 80; $f_i = 40\text{ Hz}$ <i>bass max, treble lin</i>	1
Bass boost	$V_{15.6}$		-12		dB	05, 8F; $f_i = 40\text{ Hz}$ <i>bass min, treble lin</i>	1
Bass boost	$V_{16.6}$		-12		dB	05, 8F; $f_i = 40\text{ Hz}$ <i>bass min, treble lin</i>	1
Bass boost	$V_{13.23}$		-12		dB	05, 8F; $f_i = 40\text{ Hz}$ <i>bass min, treble lin</i>	1
Bass boost	$V_{14.23}$		-12		dB	05, 8F; $f_i = 40\text{ Hz}$ <i>bass min, treble lin</i>	1
Step width bass	ΔV_{13}	1	2	3	dB	05, 8X-05.8 (X ± 1) <i>bass X-bass (X ± 1)</i>	1
Step width bass	ΔV_{14}	1	2	3	dB	05, 8X-05.8 (X ± 1) <i>bass X-bass (X ± 1)</i>	1
Step width bass	ΔV_{15}	1	2	3	dB	05, 8X-05.8 (X ± 1) <i>bass X-bass (X ± 1)</i>	1
Step width bass	ΔV_{16}	1	2	3	dB	05, 8X-05.8 (X ± 1) <i>bass X-bass (X ± 1)</i>	1

3.3 AC/DC Characteristics (cont'd)

$V_S = 10\text{ V}$, $T_A = -40\text{ }^\circ\text{C}$ to $85\text{ }^\circ\text{C}$

Parameter	Symbol	Limit Values			Unit	Test Condition	Test Circuit
		min.	typ.	max.			
Treble boost	V_{15-6}	9	12		dB	05, 09; $f_i = 15\text{ kHz}$ <i>treble max, bass lin</i>	1
Treble boost	V_{16-6}	9	12		dB	05, 09; $f_i = 15\text{ kHz}$ <i>treble max, bass lin</i>	1
Treble boost	V_{13-23}	9	12		dB	05, 09; $f_i = 15\text{ kHz}$ <i>treble max, bass lin</i>	1
Treble boost	V_{14-23}	9	12		dB	05, 09; $f_i = 15\text{ kHz}$ <i>treble max, bass lin</i>	1
Treble boost	V_{15-6}	9	12		dB	05, F9; $f_i = 15\text{ kHz}$ <i>treble min, bass lin</i>	1
Treble boost	V_{15-6}		-12		dB	05, F9; $f_i = 15\text{ kHz}$ <i>treble min, bass lin</i>	1
Treble boost	V_{16-6}		-12		dB	05, F9; $f_i = 15\text{ kHz}$ <i>treble min, bass lin</i>	1
Treble boost	V_{13-23}		-12		dB	05, F9; $f_i = 15\text{ kHz}$ <i>treble min, bass lin</i>	1
Treble boost	V_{14-23}		-12		dB	05, F9; $f_i = 15\text{ kHz}$ <i>treble min, bass lin</i>	1
Step width treble	ΔV_{13}	1	2	3	dB	05, X9-05, $(X \pm 1)$ 9 <i>treble X-treble $(X \pm 1)$</i>	1
Step width treble	ΔV_{14}	1	2	3	dB	05, X9-05, $(X \pm 1)$ 9 <i>treble X-treble $(X \pm 1)$</i>	1
Step width treble	ΔV_{15}	1	2	3	dB	05, X9-05, $(X \pm 1)$ 9 <i>treble X-treble $(X \pm 1)$</i>	1
Step width treble	ΔV_{16}	1	2	3	dB	05, X9-05, $(X \pm 1)$ 9 <i>treble X-treble $(X \pm 1)$</i>	1

3.3 AC/DC Characteristics (cont'd)

$V_S = 10\text{ V}$, $T_A = -40\text{ °C}$ to 85 °C

Parameter	Symbol	Limit Values			Unit	Test Condition	Test Circuit
		min.	typ.	max.			
Tone linearity	ΔV_{13}			± 3	dB	05, 89; $f_i = 40\text{ Hz} \dots 15\text{ kHz}$ <i>treble, bass lin</i>	1
Tone linearity	ΔV_{14}			± 3	dB	05, 89; $f_i = 40\text{ Hz} \dots 15\text{ kHz}$ <i>treble, bass lin</i>	1
Tone linearity	ΔV_{15}			± 3	dB	05, 89; $f_i = 40\text{ Hz} \dots 15\text{ kHz}$ <i>treble, bass lin</i>	1
Tone linearity	ΔV_{16}			± 3	dB	05, 89; $f_i = 40\text{ Hz} \dots 15\text{ kHz}$ <i>treble, bass lin</i>	1
Channel separation	ΔV_{14-15}	60			dB	V_6 or $V_{23} = 300\text{ mVrms}$	1
Channel separation	ΔV_{13-16}	60			dB	V_6 or $V_{23} = 300\text{ mVrms}$	1
Crosstalk of the switch ¹⁾	$\alpha_{\text{input unwanted, output wanted}}$	80			dB	$V_i^{\text{wanted}} = 0$ $V_i^{\text{unwanted}} = 300\text{ mVrms}$	1
Attenuation MUTE ²⁾	a_{1-5}	80			dB	01, 00-03, 00; $V_1 = 300\text{ mVrms}$; <i>Vol 0</i>	1
Attenuation MUTE ²⁾	a_{1-5}	80			dB	07, C0; $V_1 = 300\text{ mVrms}$ <i>MUTE active</i>	1
Attenuation MUTE ²⁾	a_{1-5}	80			dB	07, 00; $V_1 = 300\text{ mVrms}$ <i>not select</i>	1
Attenuation MUTE ³⁾	a_{28-24}	80			dB	00, 00 to 03, 00; $V_{28} = 300\text{ mVrms}$; <i>Vol 0</i>	1
Attenuation MUTE ³⁾	a_{28-24}	80			dB	07, 00; $V_{28} = 300\text{ mVrms}$ <i>MUTE active</i>	1
Attenuation MUTE ³⁾	a_{28-24}	80			dB	07, 00; $V_{28} = 300\text{ mVrms}$ <i>not select</i>	1

¹⁾ Same values apply for feeding in on pins 1 ... 4 or 25 ... 28. and measurement on pins 5 or 24.

²⁾ Analogous values apply for feeding in on pins 2, 3, 4.

³⁾ Same values apply for feeding in on pins 25, 26, 27.

3.3 AC/DC Characteristics (cont'd)

$V_S = 10\text{ V}$, $T_A = -40\text{ }^\circ\text{C}$ to $85\text{ }^\circ\text{C}$

Parameter	Symbol	Limit Values			Unit	Test Condition	Test Circuit
		min.	typ.	max.			
Max. input voltage ¹⁾	V_1	1.5			Vrms	$k_{15, 16} \leq 1\%$; $R_{L15, 16} = 2.2\text{ k}\Omega$	1
Max. input voltage ¹⁾	V_1	0.75			Vrms	$k_{15, 16} \leq 1\%$; 07, 44 $R_{L15, 16} = 2.2\text{ k}\Omega$	1
Max. input voltage ²⁾	V_{28}	1.5			Vrms	$k_{13, 14} \leq 1\%$; $R_{L13, 14} = 2.2\text{ k}\Omega$	1
Max. input voltage ²⁾	V_{28}	0.75			Vrms	$k_{13, 14} \leq 1\%$; 07, 44 $R_{L13, 14} = 2.2\text{ k}\Omega$	1
Max. input voltage	V_6	250			Vrms	$k_{15, 16} < 1\%$; 05, XX <i>any sound</i>	1
Max. input voltage	V_{23}	250			Vrms	$k_{13, 14} < 1\%$; 05, XX <i>any sound</i>	1
Max. output voltage	V_{13}	2.0			Vrms	$k_{13} < 1\%$	1
Max. output voltage	V_{14}	2.0			Vrms	$k_{14} < 1\%$	1
Max. output voltage	V_{15}	2.0			Vrms	$k_{15} < 1\%$	1
Max. output voltage	V_{16}	2.0			Vrms	$k_v < 1\%$	1
Distortion ³⁾	k_5		0.01	0.1	%	$V_1 = 150\text{ mVrms}$	1
Distortion ³⁾	k_{24}		0.01	0.1	%	$V_{28} = 150\text{ mVrms}$	1
Distortion ³⁾	k_{13}		0.01	0.1	%	$V_{28} = 150\text{ mVrms}$	1
Distortion ³⁾	k_{14}		0.01	0.1	%	$V_{28} = 150\text{ mVrms}$	1
Distortion ³⁾	k_{15}		0.01	0.1	%	$V_1 = 150\text{ mVrms}$	1
Distortion ³⁾	k_{16}		0.01	0.1	%	$V_1 = 150\text{ mVrms}$	1
Distortion ³⁾	k_{13}		0.01	0.1	%	$V_{28} = 150\text{ mVrms}$ 01, 2F; Vol 47	1
Distortion ³⁾	k_{14}		0.01	0.1	%	$V_{28} = 150\text{ mVrms}$ 03, 2F; Vol 47	1
Distortion ³⁾	k_{15}		0.01	0.1	%	$V_1 = 150\text{ mVrms}$ 02, 2F; Vol 47	1
Distortion ³⁾	k_{16}		0.01	0.1	%	$V_1 = 150\text{ mVrms}$ 00, 2F; Vol 47	1

¹⁾ Same values apply for feeding in on pins 2, 3, 4.

²⁾ Same values apply for feeding in on pins 25, 26, 27.

³⁾ Same values apply for feeding in on pins 2 ... 4 or 25 ... 27.

3.3 AC/DC Characteristics (cont'd)

$V_S = 10\text{ V}$, $T_A = -40\text{ }^\circ\text{C}$ to $85\text{ }^\circ\text{C}$

Parameter	Symbol	Limit Values			Unit	Test Condition	Test Circuit
		min.	typ.	max.			
Distortion ¹⁾	k_{13}		0.05	0.5	%	$V_{28} = 150\text{ mVrms}$ 05, XX; any sound	1
Distortion ¹⁾	k_{14}		0.05	0.5	%	$V_{28} = 150\text{ mVrms}$ 05, XX; any sound	1
Distortion ¹⁾	k_{15}		0.05	0.5	%	$V_1 = 150\text{ mVrms}$ 05, XX; any sound	1
Distortion ¹⁾	k_{16}		0.05	0.5	%	$V_1 = 150\text{ mVrms}$ 05, XX; any sound	1
Signal/noise ratio ¹⁾	a_{S-N13}	80	95		dB	V_{Nrms} 20 Hz-20 kHz $V_{28} = 0.3\text{ Vrms}$	1
Signal/noise ratio ¹⁾	a_{S-N14}	80	95		dB	V_{Nrms} 20 Hz-20 kHz $V_{28} = 0.3\text{ Vrms}$	1
Signal/noise ratio ¹⁾	a_{S-N15}	80	95		dB	V_{Nrms} 20 Hz-20 kHz $V_1 = 0.3\text{ Vrms}$	1
Signal/noise ratio ¹⁾	a_{S-N16}	80	95		dB	V_{Nrms} 20 Hz-20 kHz $V_1 = 0.3\text{ Vrms}$	1
Signal/noise ratio ¹⁾	a_{S-N13}	60	80		dB	V_{Nrms} 20 Hz-20 kHz $V_{28} = 0.3\text{ Vrms}$ 01, 27; Vol 39	1
Signal/noise ratio ¹⁾	a_{S-N14}	60	80		dB	V_{Nrms} 20 Hz-20 kHz $V_{28} = 0.3\text{ Vrms}$ 03, 27; Vol 39	1
Signal/noise ratio ¹⁾	a_{S-N15}	60	80		dB	V_{Nrms} 20 Hz-20 kHz $V_1 = 0.3\text{ Vrms}$; 02, 27	1
Signal/noise ratio ¹⁾	a_{S-N16}	60	80		dB	V_{Nrms} 20 Hz-20 kHz $V_1 = 0.3\text{ Vrms}$ 00, 27; Vol 39	1

¹⁾ Same values apply for feeding in on pins 2 ... 4 or 25 ... 27.

3.3 AC/DC Characteristics (cont'd)

$V_S = 10\text{ V}$, $T_A = -40\text{ }^\circ\text{C}$ to $85\text{ }^\circ\text{C}$

Parameter	Symbol	Limit Values			Unit	Test Condition	Test Circuit
		min.	typ.	max.			
Noise voltage	V_{N13}		2	10	μVrms	V_{Nrms} 20 Hz-20 kHz 01, 00-03, 00; Vol 0	1
Noise voltage	V_{N14}		2	10	μVrms	V_{Nrms} 20 Hz-20 kHz 00, 00-03, 00; Vol 0	1
Noise voltage	V_{N15}		2	10	μVrms	V_{Nrms} 20 Hz-20 kHz 00, 00-02, 00; Vol 0	1
Noise voltage	V_{N16}		2	10	μVrms	V_{Nrms} 20 Hz-20 kHz 01, 00-02, 00; Vol 0	1
DC jump Δ 1 bit	ΔV_{13}			± 10	mV	01, X-01, (X \pm 1) Vol X-Vol (X \pm 1)	1
DC jump Δ 1 bit	ΔV_{14}			± 10	mV	03, X-03, (X \pm 1) Vol X-Vol (X \pm 1)	1
DC jump Δ 1 bit	ΔV_{15}			± 10	mV	02, X-02, (X \pm 1) Vol X-Vol (X \pm 1)	1
DC jump Δ 1 bit	ΔV_{16}			± 10	mV	00, X-00, (X \pm 1) Vol X-Vol (X \pm 1)	1
DC jump Δ 1 bit	ΔV_{13}			± 10	mV	05, X-05, (X \pm 1) tone X-tone (X \pm 1)	1
DC jump Δ 1 bit	ΔV_{14}			± 10	mV	05, X-05, (X \pm 1) tone X-tone (X \pm 1)	1
DC jump Δ 1 bit	ΔV_{15}			± 10	mV	05, X-05, (X \pm 1) tone X-tone (X \pm 1)	1
DC jump Δ 1 bit	ΔV_{16}			± 10	mV	05, X-05, (X \pm 1) tone X-tone (X \pm 1)	1
PSRR	A_{PSRR13}		70		dB	$V_{undesired} = 1\text{ Vrms}$ $f_{undesired} = 100\text{ Hz} \dots 20\text{ kHz}$	1
PSRR	A_{PSRR14}		70		dB	input termination with $220\ \Omega$	1
PSRR	A_{PSRR15}		70		dB	measurement rms according CCIR 651	1
PSRR	A_{PSRR16}		70		dB		1

3.3 AC/DC Characteristics (cont'd)

$V_S = 10\text{ V}$, $T_A = -40\text{ °C}$ to 85 °C

Parameter	Symbol	Limit Values			Unit	Test Condition	Test Circuit
		min.	typ.	max.			

Design Hints

Input resistance	R_1	22	27		k Ω		
Input resistance	R_2	22	27		k Ω		
Input resistance	R_3	22	27		k Ω		
Input resistance	R_4	22	27		k Ω		
Input resistance	R_6	24	30		k Ω		
Input resistance	R_{23}	24	30		k Ω		
Input resistance	R_{25}	22	27		k Ω		
Input resistance	R_{26}	22	27		k Ω		
Input resistance	R_{27}	22	27		k Ω		
Input resistance	R_{28}	22	27		k Ω		
Output resistance	R_5			200	Ω		
Output resistance	R_{13}			200	Ω		
Output resistance	R_{14}			200	Ω		
Output resistance	R_{15}			200	Ω		
Output resistance	R_V			200	Ω		
Output resistance	R_{24}			200	Ω		

$V_S = 8.5\text{ V}$

Max. input voltage	V_6	180			mVrms	$k_{15,16} < 5\%$; 05, XX any sound	1
Max. input voltage	V_{23}	180			mVrms	$k_{13,14} < 5\%$; 05, XX any sound	1
Bass boost	V_{15-6}	10	12		dB	05,83; $f_i = 40\text{ Hz}$ bass step 6, treble lin	1
Bass boost	V_{16-6}	10	12		dB	05,83; $f_i = 40\text{ Hz}$ bass step 6, treble lin	1
Bass boost	V_{13-23}	10	12		dB	05,83; $f_i = 40\text{ Hz}$ bass step 6, treble lin	1
Bass boost	V_{14-23}	10	12		dB	05,83; $f_i = 40\text{ Hz}$ bass step 6, treble lin	1

3.3 AC/DC Characteristics (cont'd)

$V_S = 10\text{ V}$, $T_A = -40\text{ °C}$ to 85 °C

Parameter	Symbol	Limit Values			Unit	Test Condition	Test Circuit
		min.	typ.	max.			

$V_S = 12\text{ V}$

Max. input voltage	V_6	300			mVrms	$k_{15, 16} < 1\%$; 05, XX <i>any sound</i>	1
Max. input voltage	V_{23}	300			mVrms	$k_{13, 14} < 1\%$; 05, XX <i>any sound</i>	1

B. I²C Bus (SCL, SDA edges)

Rise time	t_R			300	ns		
Fall time	t_F			300	ns		

Shift Register Clock Pulse SCL

Frequency	f_{SCL}	0		400	kHz		
H-pulse width	t_{HIGH}	0.6			μs		
L-pulse width	t_{LOW}	1.3			μs		

Start

Set-up time	t_{SUSTA}	0.6			μs		
Hold time	t_{HDSTA}	0.6			μs		

Stop

Set-up time	t_{SUSTO}	0.6			μs		
Bus free time	t_{BUF}	1.3			μs		

Data Transfer

Set-up time	t_{SUDAT}	100			μs		
Hold time	t_{HDDAT}	0		0.9	μs		

3.3 AC/DC Characteristics (cont'd)

$V_S = 10\text{ V}$, $T_A = -40\text{ }^\circ\text{C}$ to $85\text{ }^\circ\text{C}$

Parameter	Symbol	Limit Values			Unit	Test Condition	Test Circuit
		min.	typ.	max.			

Inputs SCL, SDA

Input voltage	V_{QH}	3		5.5	V		
	V_{OL}			1.5	V		
Hysteresis	V_{HYS}	0.2			V		
Spike suppression	t_{SP}	50			ns		
Input current	I_{QH}			50	μA		
	I_{OL}			100	μA		

Output SDA (open collector)

Output voltage	V_{OH}	5.4			V	$R_L = 2.5\text{ k}\Omega$	
	V_{OL}			0.4	V	$I_{OL} = 3\text{ mA}$	
Reset inactive	V_L			1.5	V		
Reset active	V_H	3		5.5	V		

Note: The listed characteristics are ensured over the operating range of the integrated circuit. Typical characteristics specify mean values expected over the production spread. If not otherwise specified, typical characteristics apply at $T_A = 25\text{ }^\circ\text{C}$ and the given supply voltage.

3.4 AC/DC Characteristics

$V_S = 10\text{ V}$, $T_A = 25\text{ °C}$

Parameter	Symbol	Limit Values			Unit	Test Condition	Test Circuit
		min.	typ.	max.			

AF reference level 0 dB = 150 mV, $f_i = 1\text{ kHz}$, if not stated otherwise.

I²C Bus preset: Start – 82 – 00, 3F – 01, 3F – 02, 3F – 03, 3F – 05, 89 – 07, 40 – Stop

Chipaddr. – Vol 63 – Vol 63 – Vol 63 – Vol 63 – tone lin – IN1

The basic setting for each point in the specification is always preset; only settings which deviate from this, are given in the test conditions. Details in *italics* only provide explanation of the hexadecimal code and which switch bits on the setbytes are stated.

Current consumption	I_{10}		39	50	mA		1
---------------------	----------	--	----	----	----	--	---

A. Signal Section

Gain ¹⁾	V_{5-1}	-1	0	1	dB		1	
Gain ¹⁾	V_{24-28}	-1	0	1	dB		1	
Gain ¹⁾	V_{5-1}	5	6	7	dB	07, 44; <i>gain = 6 dB</i>	1	
Gain ¹⁾	V_{24-28}	5	6	7	dB	07, 44; <i>gain = 6 dB</i>	1	
Max. gain	V_{15-6}	-2	0	2	dB		1	
Max. gain	V_{16-6}	-2	0	2	dB		1	
Max. gain	V_{13-23}	-2	0	2	dB		1	
Max. gain	V_{14-23}	-2	0	2	dB		1	
Min. gain	V_{5-6}		-70	-65	dB	00, 08-02, 0; 8 <i>Vol 8</i>	1	
Min. gain	V_{16-6}		-70	-65	dB	00, 08-02, 0; 8 <i>Vol 8</i>	1	
Min. gain	V_{13-23}		-70	-65	dB	01, 08-03, 0; 8 <i>Vol 8</i>	1	
Min. gain	V_{14-23}		-70	-65	dB	01, 08-03, 08; <i>Vol 8</i>	1	
Tracking error	ΔV_{13-14}				± 2	dB	01, 3F to 01, 24 03, 3F to 03, 24; <i>Vol 63-36</i>	1
Tracking error	ΔV_{15-16}				± 2	dB	00, 3F to 00, 24 02, 3F to 02, 24; <i>Vol 63-36</i>	1
Tracking error	ΔV_{13-16}				± 2	dB	00, 3F to 00, 24 01, 3F to 01, 24; <i>Vol 63-36</i>	1
Tracking error	ΔV_{14-15}				± 2	dB	02, 3F to 02, 24 03, 3F to 03, 24; <i>Vol 63-36</i>	1

¹⁾ Same values apply for feeding in on pins 2 ... 4, and 25 ... 27.

3.4 AC/DC Characteristics (cont'd)

$V_S = 10\text{ V}$, $T_A = 25\text{ }^\circ\text{C}$

Parameter	Symbol	Limit Values			Unit	Test Condition	Test Circuit
		min.	typ.	max.			
Step width Vol ₁₃	ΔV_{13}	0	1.25	2.5	dB	01, X-01, (X ± 1) Vol X-Vol (X ± 1)	1
Step width Vol ₁₄	ΔV_{14}	0	1.25	2.5	dB	03, X-03, (X ± 1) Vol X-Vol (X ± 1)	1
Step width Vol ₁₅	ΔV_{15}	0	1.25	2.5	dB	02, X-02, (X ± 1) Vol X-Vol (X ± 1)	1
Step width Vol ₁₆	ΔV_{16}	0	1.25	2.5	dB	00, X-00, (X ± 1) Vol X-Vol (X ± 1)	1
Bass boost	V_{15-6}	16	18		dB	05, 80; $f_i = 40\text{ Hz}$ bass max, treble lin	1
Bass boost	V_{16-6}	16	18		dB	05, 80; $f_i = 40\text{ Hz}$ bass max, treble lin	1
Bass boost	V_{13-23}	16	18		dB	05, 80; $f_i = 40\text{ Hz}$ bass max, treble lin	1
Bass boost	V_{14-23}	16	18		dB	05, 80; $f_i = 40\text{ Hz}$ bass max, treble lin	1
Bass boost	V_{15-6}		- 12		dB	05, 8F; $f_i = 40\text{ Hz}$ bass min, treble lin	1
Bass boost	V_{16-6}		- 12		dB	05, 8F; $f_i = 40\text{ Hz}$ bass min, treble lin	1
Bass boost	V_{13-23}		- 12		dB	05, 8F; $f_i = 40\text{ Hz}$ bass min, treble lin	1
Bass boost	V_{14-23}		- 12		dB	05, 8F; $f_i = 40\text{ Hz}$ bass min, treble lin	1
Step width bass	ΔV_{13}	1	2	3	dB	05, 8X-05, 8 (X ± 1) bass X-bass (X ± 1)	1
Step width bass	ΔV_{14}	1	2	3	dB	05, 8X-05, 8 (X ± 1) bass X-bass (X ± 1)	1
Step width bass	ΔV_{15}	1	2	3	dB	05, 8X-05, 8 (X ± 1) bass X-bass (X ± 1)	1
Step width bass	ΔV_{16}	1	2	3	dB	05, 8X-05, 8 (X ± 1) bass X-bass (X ± 1)	1

3.4 AC/DC Characteristics (cont'd)

$V_S = 10\text{ V}$, $T_A = 25\text{ °C}$

Parameter	Symbol	Limit Values			Unit	Test Condition	Test Circuit
		min.	typ.	max.			
Treble boost	V_{15-6}	10	12		dB	05, 09; $f_i = 15\text{ kHz}$ <i>treble max, bass lin</i>	1
Treble boost	V_{16-6}	10	12		dB	05, 09; $f_i = 15\text{ kHz}$ <i>treble max, bass lin</i>	1
Treble boost	V_{13-23}	10	12		dB	05, 09; $f_i = 15\text{ kHz}$ <i>treble max, bass lin</i>	1
Treble boost	V_{14-23}	10	12		dB	05, 09; $f_i = 15\text{ kHz}$ <i>treble max, bass lin</i>	1
Treble boost	V_{15-6}	10	12		dB	05, F9; $f_i = 15\text{ kHz}$ <i>treble min, bass lin</i>	1
Treble boost	V_{15-6}		- 12		dB	05, F9; $f_i = 15\text{ kHz}$ <i>treble min, bass lin</i>	1
Treble boost	V_{16-6}		- 12		dB	05, F9; $f_i = 15\text{ kHz}$ <i>treble min, bass lin</i>	1
Treble boost	V_{13-23}		- 12		dB	05, F9; $f_i = 15\text{ kHz}$ <i>treble min, bass lin</i>	1
Treble boost	V_{14-23}		- 12		dB	05, F9; $f_i = 15\text{ kHz}$ <i>treble min, bass lin</i>	1
Step width treble	ΔV_{13}	1	2	3	dB	05, X9-05, $(X \pm 1) 9$ <i>treble X-treble $(X \pm 1)$</i>	1
Step width treble	ΔV_{14}	1	2	3	dB	05, X9-05, $(X \pm 1) 9$ <i>treble X-treble $(X \pm 1)$</i>	1
Step width treble	ΔV_{15}	1	2	3	dB	05, X9-05, $(X \pm 1) 9$ <i>treble X-treble $(X \pm 1)$</i>	1
Step width treble	ΔV_{16}	1	2	3	dB	05, X9-05, $(X \pm 1) 9$ <i>treble X-treble $(X \pm 1)$</i>	1

3.4 AC/DC Characteristics (cont'd)

$V_S = 10\text{ V}$, $T_A = 25\text{ °C}$

Parameter	Symbol	Limit Values			Unit	Test Condition	Test Circuit
		min.	typ.	max.			
Tone linearity	ΔV_{13}			± 2	dB	05, 89; $f_i = 40\text{ Hz} \dots 15\text{ kHz}$ <i>treble, bass lin</i>	1
Tone linearity	ΔV_{14}			± 2	dB	05, 89; $f_i = 40\text{ Hz} \dots 15\text{ kHz}$ <i>treble, bass lin</i>	1
Tone linearity	ΔV_{15}			± 2	dB	05, 89; $f_i = 40\text{ Hz} \dots 15\text{ kHz}$ <i>treble, bass lin</i>	1
Tone linearity	ΔV_{16}			± 2	dB	05, 89; $f_i = 40\text{ Hz} \dots 15\text{ kHz}$ <i>treble, bass lin</i>	1
Channel separation	$\Delta V_{14,15}$	60			dB	V_6 or $V_{23} = 300\text{ mVrms}$	1
Channel separation	$\Delta V_{13,16}$	60			dB	V_6 or $V_{23} = 300\text{ mVrms}$	1
Crosstalk of the switch ¹⁾	$a_{\text{input unwanted; output wanted}}$	80			dB	$V_{i \text{ wanted}} = 0$ $V_{i \text{ unwanted}} = 300\text{ mVrms}$	1
Attenuation MUTE ²⁾	$a_{1,5}$	80			dB	01, 00-03, 00; $V_1 = 300\text{ mVrms}$; <i>Vol 0</i>	1
Attenuation MUTE ²⁾	$a_{1,5}$	80			dB	07, C0; $V_1 = 300\text{ mVrms}$ <i>MUTE active</i>	1
Attenuation MUTE ²⁾	$a_{1,5}$	80			dB	07, 00; $V_1 = 300\text{ mVrms}$ <i>not select</i>	1
Attenuation MUTE ³⁾	$a_{28,24}$	80			dB	00, 00 to 03, 00; $V_{28} = 300\text{ mVrms}$; <i>Vol 0</i>	1
Attenuation MUTE ³⁾	$a_{28,24}$	80			dB	07, C0; $V_{28} = 300\text{ mVrms}$ <i>MUTE active</i>	1
Attenuation MUTE ³⁾	$a_{28,24}$	80			dB	07, 00; $V_{28} = 300\text{ mVrms}$ <i>not select</i>	1

¹⁾ Same values apply for feeding in on pins 1 ... 4 or 25 ... 28, and measurement on pins 5 or 24.

²⁾ Analogous values apply for feeding in on pins 2, 3, 4.

³⁾ Same values apply for feeding in on pins 25, 26, 27.

3.4 AC/DC Characteristics (cont'd)

$V_S = 10\text{ V}$, $T_A = 25\text{ }^\circ\text{C}$

Parameter	Symbol	Limit Values			Unit	Test Condition	Test Circuit
		min.	typ.	max.			
Max. input voltage ¹⁾	V_1	2			Vrms	$k_{15,16} \leq 1\%$; $R_{L15,16} = 2.2\text{ k}\Omega$	1
Max. input voltage ¹⁾	V_1	1			Vrms	$k_{15,16} \leq 1\%$; 07, 44 $R_{L15,16} = 2.2\text{ k}\Omega$	1
Max. input voltage ²⁾	V_{28}	2			Vrms	$k_{13,14} \leq 1\%$; $R_{L13,14} = 2.2\text{ k}\Omega$	1
Max. input voltage ²⁾	V_{28}	1			Vrms	$k_{13,14} \leq 1\%$; 07, 44 $R_{L13,14} = 2.2\text{ k}\Omega$	1
Max. input voltage	V_6	280			Vrms	$k_{15,16} < 1\%$; 05, XX <i>any sound</i>	1
Max. input voltage	V_{23}	280			Vrms	$k_{13,14} < 1\%$; 05, XX <i>any sound</i>	1
Max. output voltage	V_{13}	2.2			Vrms	$k_{13} < 1\%$	1
Max. output voltage	V_{14}	2.2			Vrms	$k_{14} < 1\%$	1
Max. output voltage	V_{15}	2.2			Vrms	$k_{15} < 1\%$	1
Max. output voltage	V_{16}	2.2			Vrms	$k_{16} < 1\%$	1
Distortion ³⁾	k_5		0.01	0.05	%	$V_1 = 150\text{ mVrms}$	1
Distortion ³⁾	k_{24}		0.01	0.05	%	$V_{28} = 150\text{ mVrms}$	1
Distortion ³⁾	k_{13}		0.01	0.05	%	$V_{28} = 150\text{ mVrms}$	1
Distortion ³⁾	k_{14}		0.01	0.05	%	$V_{28} = 150\text{ mVrms}$	1
Distortion ³⁾	k_{15}		0.01	0.05	%	$V_1 = 150\text{ mVrms}$	1
Distortion ³⁾	k_{16}		0.01	0.05	%	$V_1 = 150\text{ mVrms}$	1
Distortion ³⁾	k_{13}		0.01	0.1	%	$V_{28} = 150\text{ mVrms}$ 01, 2F; Vol 47	1
Distortion ³⁾	k_{14}		0.01	0.1	%	$V_{28} = 150\text{ mVrms}$ 03, 2F; Vol 47	1
Distortion ³⁾	k_{15}		0.01	0.1	%	$V_1 = 150\text{ mVrms}$ 02, 2F; Vol 47	1
Distortion ³⁾	k_{16}		0.01	0.1	%	$V_1 = 150\text{ mVrms}$ 00, 2F; Vol 47	1

¹⁾ Same values apply for feeding in on pins 2, 3, 4.

²⁾ Same values apply for feeding in on pins 25, 26, 27.

³⁾ Same values apply for feeding in on pins 2 ... 4 or 25 ... 27.

3.4 AC/DC Characteristics (cont'd)

$V_S = 10\text{ V}$, $T_A = 25\text{ }^\circ\text{C}$

Parameter	Symbol	Limit Values			Unit	Test Condition	Test Circuit
		min.	typ.	max.			
Distortion ¹⁾	k_{13}		0.05	0.2	%	$V_{28} = 150\text{ mVrms}$ 05, XX; any sound	1
Distortion ¹⁾	k_{14}		0.05	0.2	%	$V_{28} = 150\text{ mVrms}$ 05, XX; any sound	1
Distortion ¹⁾	k_{15}		0.05	0.2	%	$V_1 = 150\text{ mVrms}$ 05, XX; any sound	1
Distortion ¹⁾	k_{16}		0.05	0.2	%	$V_1 = 150\text{ mVrms}$ 05, XX; any sound	1
Signal/noise ratio ¹⁾	$a_{S/N13}$	90	95		dB	V_{Nrms} 20 Hz-20 kHz $V_{28} = 0.3\text{ Vrms}$	1
Signal/noise ratio ¹⁾	$a_{S/N14}$	90	95		dB	V_{Nrms} 20 Hz-20 kHz $V_{28} = 0.3\text{ Vrms}$	1
Signal/noise ratio ¹⁾	$a_{S/N15}$	90	95		dB	V_{Nrms} 20 Hz-20 kHz $V_1 = 0.3\text{ Vrms}$	1
Signal/noise ratio ¹⁾	$a_{S/N16}$	90	95		dB	V_{Nrms} 20 Hz-20 kHz $V_1 = 0.3\text{ Vrms}$	1
Signal/noise ratio ¹⁾	$a_{S/N13}$	70	80		dB	V_{Nrms} 20 Hz-20 kHz $V_{28} = 0.3\text{ Vrms}$ 01, 27; Vol 39	1
Signal/noise ratio ¹⁾	$a_{S/N14}$	70	80		dB	V_{Nrms} 20 Hz-20 kHz $V_{28} = 0.3\text{ Vrms}$ 03, 27; Vol 39	1
Signal/noise ratio ¹⁾	$a_{S/N15}$	70	80		dB	V_{Nrms} 20 Hz-20 kHz $V_1 = 0.3\text{ Vrms}$; 02, 27	1
Signal/noise ratio ¹⁾	$a_{S/N16}$	70	80		dB	V_{Nrms} 20 Hz-20 kHz $V_1 = 0.3\text{ Vrms}$ 00, 27; Vol 39	1

¹⁾ Same values apply for feeding in on pins 2 ... 4 or 25 ... 27.

3.4 AC/DC Characteristics (cont'd)

$V_S = 10\text{ V}$, $T_A = 25\text{ °C}$

Parameter	Symbol	Limit Values			Unit	Test Condition	Test Circuit
		min.	typ.	max.			
Noise voltage	V_{N13}		2	5	μVrms	$V_{Nrms\ 20\text{ Hz-20 kHz}}$ 01, 00-03, 00; <i>Vol 0</i>	1
Noise voltage	V_{N14}		2	5	μVrms	$V_{Nrms\ 20\text{ Hz-20 kHz}}$ 01, 00-03, 00; <i>Vol 0</i>	1
Noise voltage	V_{N15}		2	5	μVrms	$V_{Nrms\ 20\text{ Hz-20 kHz}}$ 00, 00-02, 00; <i>Vol 0</i>	1
Noise voltage	V_{N16}		2	5	μVrms	$V_{Nrms\ 20\text{ Hz-20 kHz}}$ 00, 00-02, 00; <i>Vol 0</i>	1
DC jump $\Delta 1$ bit	ΔV_{13}			± 10	mV	01, X-01, ($X \pm 1$) <i>Vol X-Vol ($X \pm 1$)</i>	1
DC jump $\Delta 1$ bit	ΔV_{14}			± 10	mV	03, X-03, ($X \pm 1$) <i>Vol X-Vol ($X \pm 1$)</i>	1
DC jump $\Delta 1$ bit	ΔV_{15}			± 10	mV	02, X-02, ($X \pm 1$) <i>Vol X-Vol ($X \pm 1$)</i>	1
DC jump $\Delta 1$ bit	ΔV_{16}			± 10	mV	00, X-00, ($X \pm 1$) <i>Vol X-Vol ($X \pm 1$)</i>	1
DC jump $\Delta 1$ bit	ΔV_{13}			± 10	mV	05, X-05, ($X \pm 1$) <i>tone X-tone ($X \pm 1$)</i>	1
DC jump $\Delta 1$ bit	ΔV_{14}			± 10	mV	05, X-05, ($X \pm 1$) <i>tone X-tone ($X \pm 1$)</i>	1
DC jump $\Delta 1$ bit	ΔV_{15}			± 10	mV	05, X-05, ($X \pm 1$) <i>tone X-tone ($X \pm 1$)</i>	1
DC jump $\Delta 1$ bit	ΔV_{16}			± 10	mV	05, X-05, ($X \pm 1$) <i>tone X-tone ($X \pm 1$)</i>	1
PSRR	A_{PSRR13}		70		dB	$V_{undesired} = 1\text{ Vrms}$ $f_{undesired} = 100\text{ Hz} \dots 20\text{ kHz}$	1
PSRR	A_{PSRR14}		70		dB	input termination with $220\ \Omega$	1
PSRR	A_{PSRR15}		70		dB	measurement rms according CCIR 651	1
PSRR	A_{PSRR16}		70		dB		1

3.4 AC/DC Characteristics (cont'd)

$V_S = 10\text{ V}$, $T_A = 25\text{ °C}$

Parameter	Symbol	Limit Values			Unit	Test Condition	Test Circuit
		min.	typ.	max.			

Design Hints

Input resistance	R_1	23	27		k Ω		
Input resistance	R_2	23	27		k Ω		
Input resistance	R_3	23	27		k Ω		
Input resistance	R_4	23	27		k Ω		
Input resistance	R_6	25.5	30		k Ω		
Input resistance	R_{23}	25.5	30		k Ω		
Input resistance	R_{25}	23	27		k Ω		
Input resistance	R_{26}	23	27		k Ω		
Input resistance	R_{27}	23	27		k Ω		
Input resistance	R_{28}	23	27		k Ω		
Output resistance	R_5			200	Ω		
Output resistance	R_{13}			200	Ω		
Output resistance	R_{14}			200	Ω		
Output resistance	R_{15}			200	Ω		
Output resistance	R_{16}			200	Ω		
Output resistance	R_{24}			200	Ω		

$V_S = 8.5\text{ V}$

Max. input voltage	V_6	220			mVrms	$k_{15,16} < 5\%$; 05, XX <i>any sound</i>	1
Max. input voltage	V_{23}	220			mVrms	$k_{13,14} < 5\%$; 05, XX <i>any sound</i>	1
Bass boost	$V_{15,6}$	11	12		dB	05,83; $f_c = 40\text{ Hz}$ bass step 6, treble lin	1
Bass boost	$V_{16,6}$	11	12		dB	05,83; $f_c = 40\text{ Hz}$ bass step 6, treble lin	1
Bass boost	$V_{13,23}$	11	12		dB	05,83; $f_c = 40\text{ Hz}$ bass step 6, treble lin	1
Bass boost	$V_{14,23}$	11	12		dB	05,83; $f_c = 40\text{ Hz}$ bass step 6, treble lin	1

3.4 AC/DC Characteristics (cont'd)

$V_S = 10\text{ V}$, $T_A = 25\text{ }^\circ\text{C}$

Parameter	Symbol	Limit Values			Unit	Test Condition	Test Circuit
		min.	typ.	max.			

$V_S = 12\text{ V}$

Max. input voltage	V_6	370			mVrms	$k_{15,16} < 1\%$; 05, XX <i>any sound</i>	1
Max. input voltage	V_{23}	370			mVrms	$k_{13,14} < 1\%$; 05, XX <i>any sound</i>	1

B. I²C Bus (SCL, SDA edges)

Rise time	t_R			300	ns		
Fall time	t_F			300	ns		

Shift Register Clock Pulse SCL

Frequency	f_{SCL}	0		400	kHz		
H-pulse width	t_{HIGH}	0.6			μs		
L-pulse width	t_{LOW}	1.3			μs		

Start

Set-up time	t_{SUSTA}	0.6			μs		
Hold time	t_{HDSTA}	0.6			μs		

Stop

Set-up time	t_{SUSTO}	0.6			μs		
Bus free time	t_{BUF}	1.3			μs		

Data Transfer

Set-up time	t_{SUDAT}	100			μs		
Hold time	t_{HDDAT}	0		0.9	μs		

3.4 AC/DC Characteristics (cont'd)

$V_S = 10\text{ V}$, $T_A = 25\text{ °C}$

Parameter	Symbol	Limit Values			Unit	Test Condition	Test Circuit
		min.	typ.	max.			

Inputs SCL, SDA

Input voltage	V_{QH}	3		5.5	V		
	V_{QL}			1.5	V		
Hysteresis	V_{HYS}	0.2			V		
Spike suppression	t_{SP}	50			ns		
Input current	I_{QH}			50	μA		
	I_{QL}			100	μA		

Output SDA (open collector)

Output voltage	V_{QH}	5.4			V	$R_L = 2.5\text{ k}\Omega$	
	V_{QL}			0.4	V	$I_{QL} = 3\text{ mA}$	
Reset inactive	V_L			1.5	V		
Reset active	V_H	3		5.5	V		

Note: The listed characteristics are ensured over the operating range of the integrated circuit. Typical characteristics specify mean values expected over the production spread. If not otherwise specified, typical characteristics apply at $T_A = 25\text{ °C}$ and the given supply voltage.

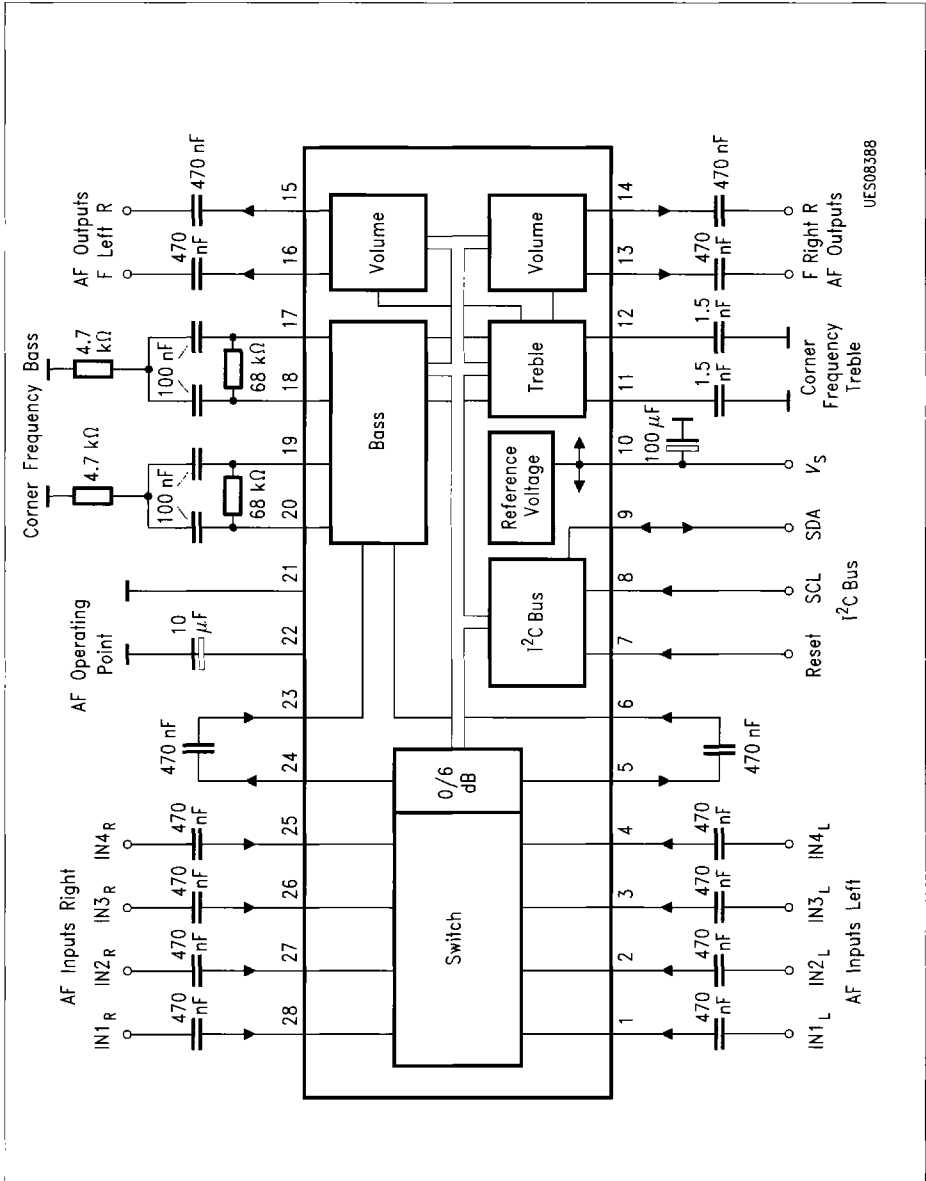

UES08388

Figure 12
Application Circuit

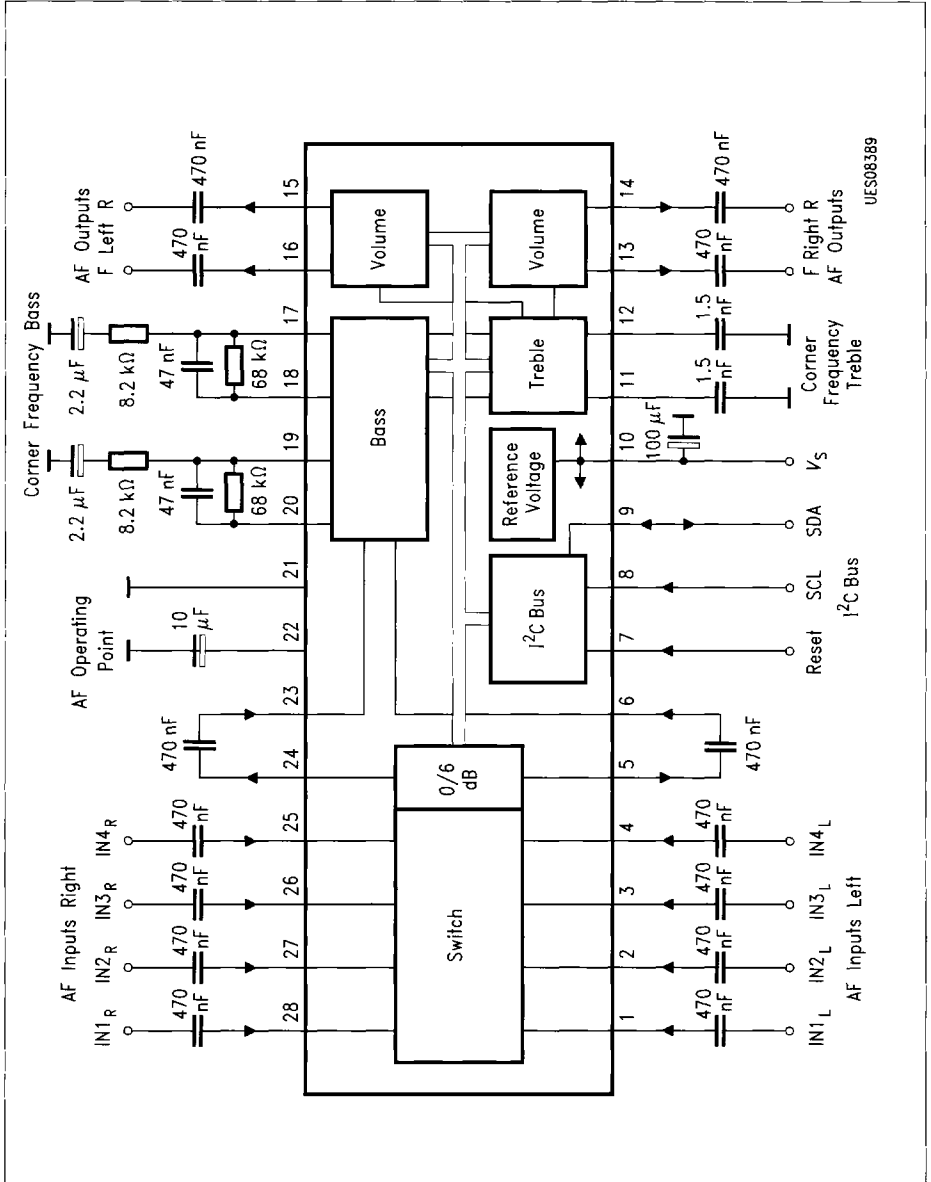

UES08389

Figure 13 Application Circuit

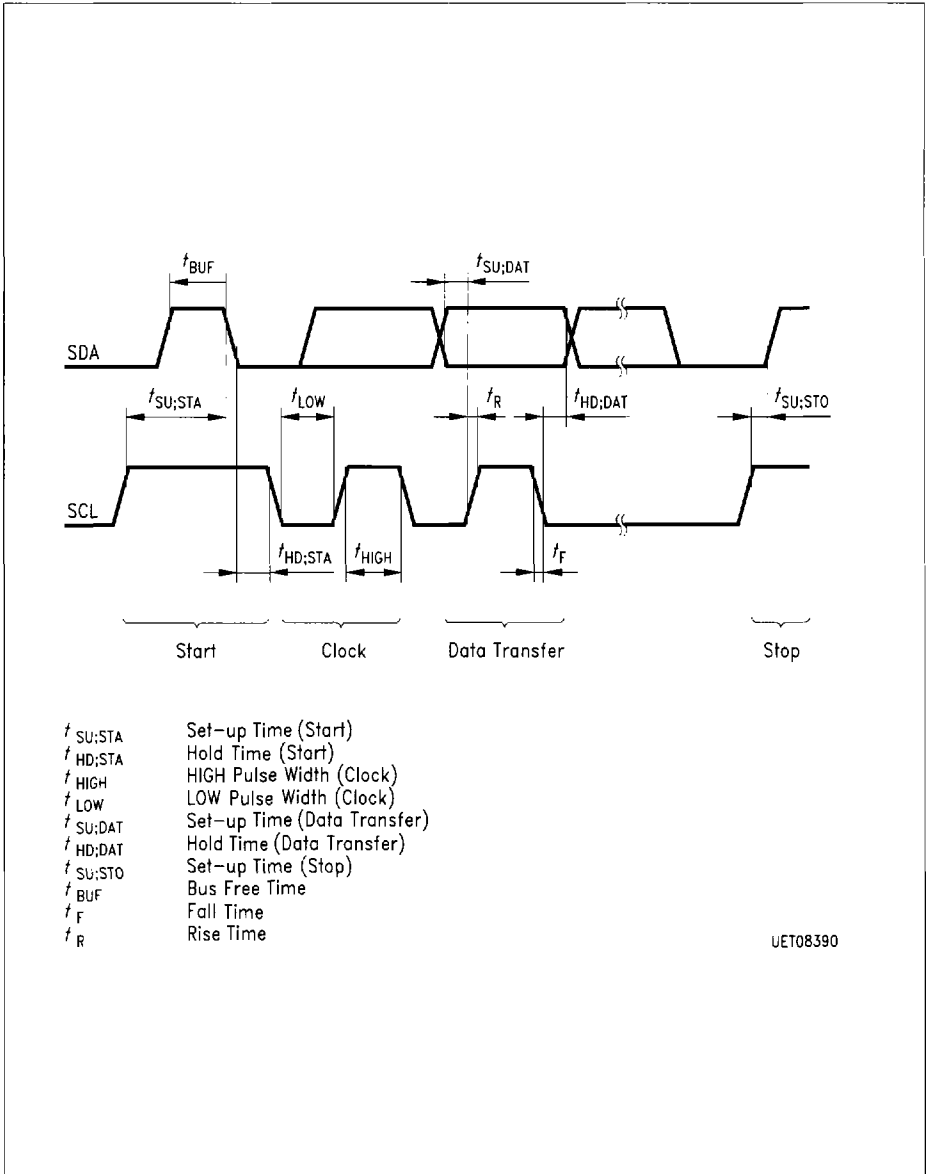

UET08390

Figure 14
I²C Bus Timing

4 Package Outlines

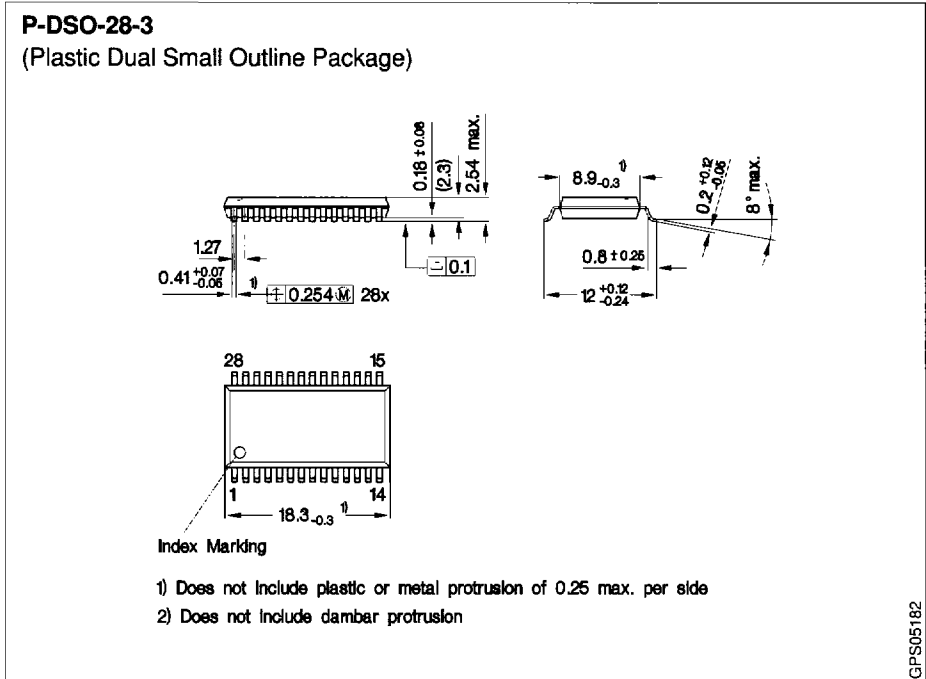

Sorts of Packing

Package outlines for tubes, trays etc. are contained in our Data Book "Package Information".

SMD = Surface Mounted Device

Dimensions in mm