

**FEATURES**

- 200 MHz ARM920T Processor
  - 16 Kbyte Instruction Cache
  - 16 Kbyte Data Cache
  - Linux®, Microsoft® Windows® CE enabled MMU
  - 100 MHz System Bus
- MaverickCrunch™ Math Engine
  - Floating point, integer and signal processing instructions
  - Optimized for digital music compression and decompression algorithms
  - Hardware interlocks allow in-line coding
- MaverickKey™ IDs
  - 32-bit unique ID can be used for DRM compliance
  - 128-bit random ID
- Integrated Peripheral Interfaces
  - 32-bit SDRAM Interface up to 4 banks
  - 32/16-bit SRAM/FLASH/ROM
  - Serial EEPROM Interface
  - 1/10/100 Mbps Ethernet MAC
  - Three UARTs
  - Three-port USB 2.0 Full Speed Host (OHCI) (12 Mbits per second)
  - IrDA Interface
  - LCD and Raster Interface with Graphics Accelerator

**ARM9 SOC with Ethernet, USB, Display and Touchscreen**

- Touchscreen Interface with ADC
- 8 x 8 Keypad Scanner
- One Serial Peripheral Interface (SPI) Port
- 6-channel or 2-channel Serial Audio Interface (I<sup>2</sup>S)
- 2-channel low-cost Serial Audio Interface (AC'97)
- Internal Peripherals
  - 12 Direct Memory Access (DMA) Channels
  - Real-time Clock with software Trim
  - Dual PLL controls all clock domains
  - Watchdog Timer
  - Two general purpose 16-bit timers
  - One general purpose 32-bit timer
  - One 40-bit Debug Timer
  - Interrupt Controller
  - Boot ROM
- Package
  - 272 pin TFBGA

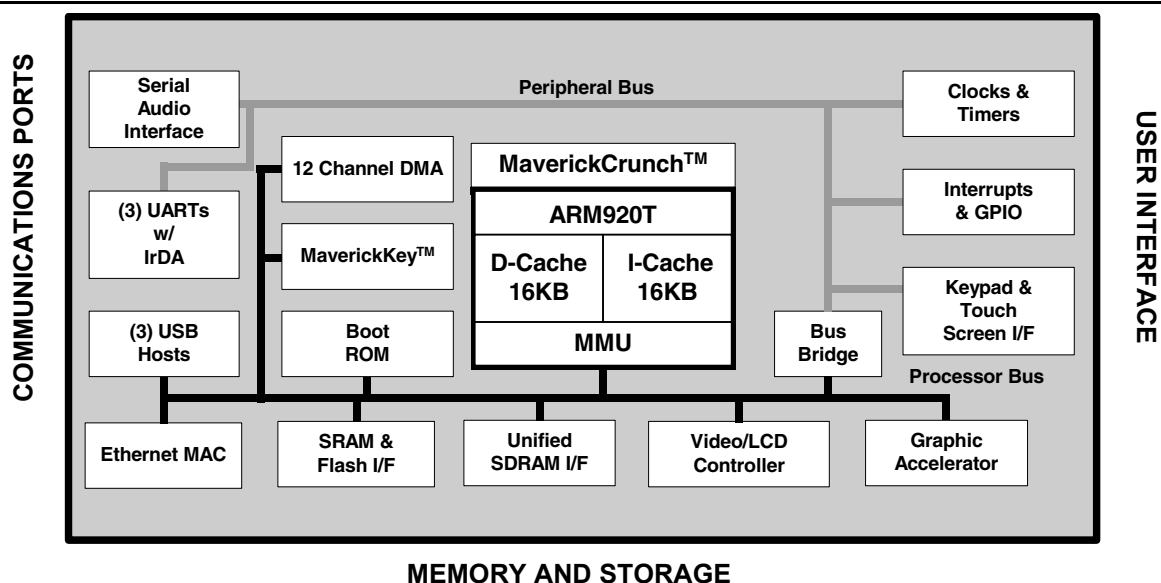



---

**Table of Contents**

|  |           |
|--|-----------|
| <b>FEATURES</b> .....  | <b>1</b>  |
| <b>OVERVIEW</b> .....  | <b>2</b>  |
| Processor Core - ARM920T .....   | 6         |
| MaverickCrunch™ Math Engine .....  | 6         |
| MaverickKey™ Unique ID .....   | 6         |
| General Purpose Memory Interface (SDRAM, SRAM, ROM, FLASH) .....           | 6         |
| Ethernet Media Access Controller (MAC) .....                               | 7         |
| Serial Interfaces (SPI, I2S and AC '97) .....                              | 7         |
| Raster/LCD Interface .....   | 7         |
| Graphics Accelerator .....   | 8         |
| Touch Screen Interface with 12-bit Analog-to-Digital Converter (ADC) ..... | 8         |
| 64-Keypad Interface .....  | 8         |
| Universal Asynchronous Receiver/Transmitters (UARTs) .....                 | 9         |
| Internal Boot ROM .....  | 9         |
| Triple Port USB Host .....   | 9         |
| Two-Wire Interface With EEPROM Support .....                               | 9         |
| Real-Time Clock with Software Trim .....                                   | 10        |
| PLL and Clocking .....   | 10        |
| Timers .....   | 10        |
| Interrupt Controller .....   | 10        |
| Dual LED Drivers .....   | 10        |
| General Purpose Input/Output (GPIO) .....                                  | 10        |
| Reset and Power Management .....   | 11        |
| Hardware Debug Interface .....   | 11        |
| 12-Channel DMA Controller .....  | 11        |
| <b>Electrical Specifications</b> .....                                     | <b>12</b> |
| Absolute Maximum Ratings .....   | 12        |
| Recommended Operating Conditions .....                                     | 12        |
| DC Characteristics .....   | 13        |
| <b>Timings</b> .....   | <b>14</b> |
| Memory Interface .....   | 15        |
| Ethernet MAC Interface .....   | 29        |
| Audio Interface .....  | 31        |
| AC'97 .....  | 35        |
| LCD Interface .....  | 36        |
| ADC .....  | 37        |
| JTAG .....   | 38        |
| <b>272 Pin TFBGA Package Outline</b> .....                                 | <b>39</b> |
| 272 TFBGA Diagram .....  | 39        |
| 272 Pin TFBGA Pinout (Bottom View) .....                                   | 40        |
| <b>Acronyms and Abbreviations</b> .....                                    | <b>47</b> |
| <b>Units of Measurement</b> .....  | <b>47</b> |
| <b>ORDERING INFORMATION</b> .....  | <b>48</b> |

## List of Figures

|  |    |
|--|----|
| Figure 1. Timing Diagram Drawing Key .....   | 14 |
| Figure 2. SDRAM Load Mode Register Cycle Timing Measurement .....                  | 15 |
| Figure 3. SDRAM Burst Read Cycle Timing Measurement .....                          | 16 |
| Figure 4. SDRAM Burst Write Cycle Timing Measurement .....                         | 17 |
| Figure 5. SDRAM Auto Refresh Cycle Timing Measurement .....                        | 18 |
| Figure 6. Static Memory Single Word Read Cycle Timing Measurement .....            | 19 |
| Figure 7. Static Memory Single Word Write Cycle Timing Measurement .....           | 20 |
| Figure 8. Static Memory Multiple Word Read 8 Bit Cycle Timing Measurement .....    | 21 |
| Figure 9. Static Memory Multiple Word Write 8 bit Cycle Timing Measurement .....   | 22 |
| Figure 10. Static Memory Multiple Word Read 16 Bit Cycle Timing Measurement .....  | 23 |
| Figure 11. Static Memory Multiple Word Write 16 bit Cycle Timing Measurement ..... | 24 |
| Figure 12. Static Memory Burst Read Cycle Timing Measurement .....                 | 25 |
| Figure 13. Static Memory Single Read Wait Cycle Timing Measurement .....           | 26 |
| Figure 14. Static Memory Single Write Wait Cycle Timing Measurement .....          | 27 |
| Figure 15. Static Memory Turnaround Cycle Timing Measurement .....                 | 28 |
| Figure 16. Ethernet MAC Timing Measurement .....                                   | 30 |
| Figure 17. SPI Single Transfer Timing Measurement .....                            | 32 |
| Figure 18. Microwire Frame Format, Single Transfer .....                           | 32 |
| Figure 19. SPI Format with SPH=1 Timing Measurement .....                          | 33 |
| Figure 20. Inter-IC Sound (I2S) Timing Measurement .....                           | 34 |
| Figure 21. AC '97 Configuration Timing Measurement .....                           | 35 |
| Figure 22. LCD Timing Measurement .....  | 36 |
| Figure 23. ADC Transfer Function .....   | 37 |
| Figure 24. JTAG Timing Measurement .....   | 38 |
| Figure 25. 272 Pin TFBGA Diagram .....   | 39 |
| Figure 26. 272 Pin TFBGA Pinout .....  | 41 |

---

**List of Tables**

|   |    |
|---|----|
| Table A. Change History .....   | 2  |
| Table B. General Purpose Memory Interface Pin Assignments .....                             | 6  |
| Table C. Ethernet Media Access Controller Pin Assignments .....                             | 7  |
| Table D. Audio Interfaces Pin Assignment .....  | 7  |
| Table E. LCD Interface Pin Assignments .....  | 8  |
| Table F. Touch Screen Interface with 12-bit Analog-to-Digital Converter Pin Assignments ... | 8  |
| Table G. 64-Key Keypad Interface Pin Assignments .....                                      | 8  |
| Table H. Universal Asynchronous Receiver / Transmitters Pin Assignments .....               | 9  |
| Table I. Triple Port USB Host Pin Assignments .....   | 9  |
| Table J. Two-Wire Port with EEPROM Support Pin Assignments .....                            | 9  |
| Table K. Real-Time Clock with Pin Assignments .....   | 10 |
| Table L. PLL and Clocking Pin Assignments .....   | 10 |
| Table M. Interrupt Controller Pin Assignment .....  | 10 |
| Table N. Dual LED Pin Assignments .....   | 10 |
| Table O. General Purpose Input/Output Pin Assignment .....                                  | 11 |
| Table P. Reset and Power Management Pin Assignments .....                                   | 11 |
| Table Q. Hardware Debug Interface .....   | 11 |
| Table R. 272 Pin Diagram Dimensions .....   | 40 |
| Table S. Pin Descriptions .....   | 44 |
| Table T. Pin Multiplex Usage Information .....  | 46 |

## Processor Core - ARM920T

The ARM920T is a Harvard architecture processor with separate 16 Kbyte instruction and data caches with an 8-word line length but a unified memory. The processor utilizes a five-stage pipeline consisting of fetch, decode, execute, memory and write stages. Key features include:

- ARM (32-bit) and Thumb (16-bit compressed) instruction sets
- 32-bit Advanced Micro-Controller Bus Architecture (AMBA)
- 16 Kbyte Instruction Cache with lockdown
- 16 Kbyte Data Cache (programmable write-through or write-back) with lockdown
- MMU for Linux<sup>®</sup>, Microsoft<sup>®</sup> Windows<sup>®</sup> CE and other operating systems
- Translation Look Aside Buffers with 64 Data and 64 Instruction Entries
- Programmable Page Sizes of 64 Kbyte, 4 Kbyte, and 1 Kbyte
- Independent lockdown of TLB Entries

## MaverickCrunch<sup>™</sup> Math Engine

The MaverickCrunch Engine is a mixed-mode coprocessor designed primarily to accelerate the math processing required to rapidly encode digital audio formats. It accelerates single and double precision integer and floating point operations plus an integer multiply-accumulate (MAC) instruction that is considerably faster than the ARM920T's native MAC instruction. The ARM920T coprocessor interface is utilized thereby sharing its memory interface and instruction stream. Hardware forwarding and interlock allows the ARM to handle looping and addressing while MaverickCrunch handles computation. Features include:

- IEEE-754 single and double precision floating point
- 32/64-bit integer
- Add/multiply/compare
- Integer MAC 32-bit input with 72-bit accumulate
- Integer Shifts
- Floating point to/from integer conversion
- Sixteen 64-bit register files
- Four 72-bit accumulators

## MaverickKey<sup>™</sup> Unique ID

MaverickKey unique hardware programmed IDs are a solution to the growing concern over secure web content and commerce. With Internet security playing an important role in the delivery of digital media such as books or music, traditional software methods are quickly becoming unreliable. The MaverickKey unique IDs

provide OEMs with a method of utilizing specific hardware IDs such as those assigned for SDMI (Secure Digital Music Initiative) or any other authentication mechanism.

Both a specific 32-bit ID as well as a 128-bit random ID is programmed into the EP9307 through the use of laser probing technology. These IDs can then be used to match secure copyrighted content with the ID of the target device the EP9307 is powering, and then deliver the copyrighted information over a secure connection. In addition, secure transactions can benefit by also matching device IDs to server IDs. MaverickKey IDs provide a level of hardware security required for today's Internet appliances.

## General Purpose Memory Interface (SDRAM, SRAM, ROM, FLASH)

The EP9307 features a unified memory address model where all memory devices are accessed over a common address/data bus. A separate internal port is dedicated to the read-only Raster/LCD refresh engine, while the rest of the memory accesses are performed via the Processor bus. The SRAM memory controller supports 8, 16 and 32-bit devices and accommodates an internal boot ROM concurrently with 32-bit SDRAM memory.

- 1-4 banks of 32-bit, 100 MHz SDRAM
- One internal port dedicated to the Raster/LCD Refresh Engine (Read Only)
- One internal port dedicated to the rest of the chip via the Processor bus
- Address and data bus shared between SDRAM, SRAM, ROM, and FLASH memory
- Both NAND and NOR FLASH memory supported

Table B. General Purpose Memory Interface Pin Assignments

| Pin Mnemonic          | Pin Description                   |
|-----------------------|-----------------------------------|
| SDCLK                 | SDRAM Clock                       |
| SDCLKEN               | SDRAM Clock Enable                |
| SDCSn[3:0]            | SDRAM Chip Selects 3-0            |
| RASn                  | SDRAM RAS                         |
| CASn                  | SDRAM CAS                         |
| SDWEn                 | SDRAM Write Enable                |
| CSn[7:6] and CSn[3:0] | Chip Selects 7, 6, 3, 2, 1, 0     |
| AD[25:0]              | Address Bus 25-0                  |
| DA[31:0]              | Data Bus 31-0                     |
| DQMn[3:0]             | SDRAM Output Enables / Data Masks |
| WRn                   | SRAM Write Strobe                 |
| RDn                   | SRAM Read/OE Strobe               |
| WAITn                 | SRAM Wait Input                   |

## Ethernet Media Access Controller (MAC)

The MAC subsystem is compliant with the ISO/TEC 802.3 topology for a single shared medium with several stations. Multiple MII-compliant PHYs are supported. Features include:

- Supports 1/10/100 Mbps transfer rates for home/small-business/large-business applications
- Interfaces to an off-chip PHY through industry standard Media Independent Interface (MII)

**Table C. Ethernet Media Access Controller Pin Assignments**

| Pin Mnemonic | Pin Description       |
|--------------|-----------------------|
| MDC          | Management Data Clock |
| MDIO         | Management Data I/O   |
| RXCLK        | Receive Clock         |
| MIIRXD[3:0]  | Receive Data          |
| RXDVAL       | Receive Data Valid    |
| RXERR        | Receive Data Error    |
| TXCLK        | Transmit Clock        |
| MIITXD[3:0]  | Transmit Data         |
| TXEN         | Transmit Enable       |
| TXERR        | Transmit Error        |
| CRS          | Carrier Sense         |
| CLD          | Collision Detect      |

## Serial Interfaces (SPI, I<sup>2</sup>S and AC '97)

The SPI port can be configured as a master or a slave, supporting the National Semiconductor®, Motorola® and Texas Instruments® signaling protocols.

The AC'97 port supports multiple codecs for multichannel audio output with a single stereo input. The I<sup>2</sup>S port can be configured to support two channel, 24 bit audio.

These ports are multiplexed so that I<sup>2</sup>S port 0 will take over either the AC'97 pins or the SPI pins. The second and third I<sup>2</sup>S ports' serial input and serial output pins are multiplexed with EGPI0[4,5,6,13]. The clocks supplied in the first I<sup>2</sup>S port are also used for the second and third I<sup>2</sup>S ports.

- Normal Mode: One SPI Port and one AC'97 Port
- I<sup>2</sup>S on SSP Mode: One AC'97 Port and up to three I<sup>2</sup>S Ports
- I<sup>2</sup>S on AC'97 Mode: One SPI Port and up to three I<sup>2</sup>S Ports

*Note: I<sup>2</sup>S may not be output on AC'97 and SSP ports at the same time.*

**Table D. Audio Interfaces Pin Assignment**

| Pin Name | Normal Mode         | I <sup>2</sup> S on SSP Mode       | I <sup>2</sup> S on AC'97 Mode |
|----------|---------------------|------------------------------------|--------------------------------|
|          | Pin Description     | Pin Description                    | Pin Description                |
| SCLK1    | SPI Bit Clock       | I <sup>2</sup> S Serial Clock      | SPI Bit Clock                  |
| SFRM1    | SPI Frame Clock     | I <sup>2</sup> S Frame Clock       | SPI Frame Clock                |
| SSPRX1   | SPI Serial Input    | I <sup>2</sup> S Serial Input      | SPI Serial Input               |
| SSPTX1   | SPI Serial Output   | I <sup>2</sup> S Serial Output     | SPI Serial Output              |
|          |                     | (No I <sup>2</sup> S Master Clock) |                                |
| ARSTn    | AC'97 Reset         | AC'97 Reset                        | I <sup>2</sup> S Master Clock  |
| ABITCLK  | AC'97 Bit Clock     | AC'97 Bit Clock                    | I <sup>2</sup> S Serial Clock  |
| ASYN     | AC'97 Frame Clock   | AC'97 Frame Clock                  | I <sup>2</sup> S Frame Clock   |
| ASDI     | AC'97 Serial Input  | AC'97 Serial Input                 | I <sup>2</sup> S Serial Input  |
| ASDO     | AC'97 Serial Output | AC'97 Serial Output                | I <sup>2</sup> S Serial Output |

## Raster/LCD Interface

The Raster/LCD interface provides data and interface signals for a variety of display types. It features fully programmable video interface timing for non-interlaced flat panel or dual scan displays. Resolutions up to 1280 x 1024 are supported from a unified SDRAM based frame buffer. A 16-bit PWM provides control for LCD panel contrast. LCD specific features include:

- Timing and interface signals for digital LCD and TFT displays
- Full programmability for either non-interlaced or dual-scan color and grayscale flat panel displays
- Dedicated data path to SDRAM controller for improved system performance
- Pixel depths of 4, 8, 16, or 18-bits per pixel or 256 levels of grayscale
- Hardware Cursor up to 64 x 64 pixels
- 256 x 18 Color Lookup Table
- Hardware Blinking
- 8-bit interface to low end panel

Table E. LCD Interface Pin Assignments

| Pin Mnemonic | Pin Description                                     |
|--------------|---|
| SPCLK        | Pixel Clock   |
| P[17:0]      | Pixel Data Bus [17:0]                               |
| HSYNC/LP     | Horizontal Synchronization/Line Pulse               |
| VCSYNC/FP    | Vertical or Composite Synchronization / Frame Pulse |
| BLANK        | Composite Blank                                     |
| BRIGHT       | Pulse Width Modulated Brightness                    |

## Graphics Accelerator

The EP9307 contains a hardware graphics acceleration engine that improves graphic performance by handling block copy, block fill and hardware line draw operations. The Graphics Accelerator is used in the system to off-load graphics operations from the processor.

Pixel depths supported by the Graphics Accelerator are 4, 8, 16 or 24 bits per pixel (bpp). The 24 bits per pixel mode can be operated as packed (4 pixels every 3 words) or unpacked (1 pixel per word with the high byte unused.)

The block copy operations of the Graphics Accelerator are similar to a DMA (Direct Memory Access) transfer that understands pixel organization, block width, transparency, and transformation from 1bpp to higher 4, 8, 16 or 24 bpp.

The line draw operations also allow for solid lines or dashed lines. The colors for line drawing can be either foreground color and background color or foreground color with the background being transparent.

## Touch Screen Interface with 12-bit Analog-to-Digital Converter (ADC)

The touch screen interface performs all sampling, averaging, ADC range checking, and control for a wide variety of analog resistive touch screens. This controller only interrupts the processor when a meaningful change occurs. The touch screen hardware may be disabled and the switch matrix and ADC controlled directly if desired. Features include:

- Support for 4, 5, 7, or 8-wire analog resistive touch screens.
- Flexibility - unused lines may be used for temperature sensing or other functions.
- Touch screen interrupt function.

Table F. Touch Screen Interface with 12-bit Analog-to-Digital Converter Pin Assignments

| Pin Mnemonic | Pin Description                          |
|--------------|--|
| Xp, Xm       | Touch screen ADC X Axis                  |
| Yp, Ym       | Touch screen ADC Y Axis                  |
| SXp, SXm     | Touch screen ADC X Axis Voltage Feedback |
| SYp, SYm     | Touch screen ADC Y Axis Voltage Feedback |

## 64-Keypad Interface

The keypad circuitry scans an 8 x 8 array of 64 normally open, single pole switches. Any one or two keys depressed will be de-bounced and decoded. An interrupt is generated whenever a stable set of depressed keys is detected. If the keypad is not utilized, the 16 column/row pins may be used as general purpose I/O. The Keypad interface:

- Provides scanning, debounce and decoding for a 64-key array.
- Scans an 8-row by 8-column matrix.
- May decode 2 keys at once.
- Generates an interrupt when a new stable key is determined.
- Also generates a 3-key reset interrupt.

Table G. 64-Key Keypad Interface Pin Assignments

| Pin Mnemonic | Pin Description          | Alternative Usage   |
|--------------|--------------------------|---------------------|
| COL[7:0]     | Key Matrix Column Inputs | General Purpose I/O |
| ROW[7:0]     | Key Matrix Row Inputs    | General Purpose I/O |

## Universal Asynchronous Receiver/Transmitters (UARTs)

Three 16550-compatible UARTs are supplied. Two provide asynchronous HDLC (High-level Data Link Control) protocol support for full duplex transmit and receive. The HDLC receiver handles framing, address matching, CRC checking, control-octet transparency, and optionally passes the CRC to the host at the end of the packet. The HDLC transmitter handles framing, CRC generation, and control-octet transparency. The host must assemble the frame in memory before transmission. The HDLC receiver and transmitter use the UART FIFOs to buffer the data streams. A third IrDA® compatible UART is also supplied.

- UART1 supports modem bit rates up to 115.2 Kbps, supports HDLC and includes a 16 byte FIFO for receive and a 16 byte FIFO for transmit. Interrupts are generated on Rx, Tx and modem status change.
- UART2 contains an IrDA encoder operating at either the slow (up to 115 Kbps), medium (0.576 or 1.152 Mbps), or fast (4 Mbps) IR data rates. It also has a 16 byte FIFO for receive and a 16 byte FIFO for transmit.
- UART3 supports HDLC and includes a 16 byte FIFO for receive and a 16 byte FIFO for transmit. Interrupts are generated on Rx and Tx.

**Table H. Universal Asynchronous Receiver / Transmitters Pin Assignments**

| Pin Mnemonic                       | Pin Name - Description                     |
|------------------------------------|--|
| TXD0                               | UART1 Transmit                             |
| RXD0                               | UART1 Receive                              |
| CTS <sub>n</sub>                   | UART1 Clear To Send / Transmit Enable      |
| DSR <sub>n</sub> /DCD <sub>n</sub> | UART1 Data Set Ready / Data Carrier Detect |
| DTR <sub>n</sub>                   | UART1 Data Terminal Ready                  |
| RTS <sub>n</sub>                   | UART1 Ready To Send                        |
| EGPIO[0]/RI                        | UART1 Ring Indicator                       |
| TXD1/SIROUT                        | UART2 Transmit / IrDA Output               |
| RXD1/SIRIN                         | UART2 Receive / IrDA Input                 |
| TXD2                               | UART3 Transmit                             |
| RXD2                               | UART3 Receive                              |
| TEN <sub>n</sub>                   | HDLC3 Transmit Enable                      |

## Internal Boot ROM

The Internal 16 Kbyte ROM allows booting from FLASH memory, SPI or UART.

## Triple Port USB Host

The USB Open Host Controller Interface (Open HCI) provides full speed serial communications ports at a baud rate of 12 Mbits/sec. Up to 127 USB devices (printer, mouse, camera, keyboard, etc.) and USB hubs can be connected to the USB host in the USB “tiered-start” topology.

This includes the following features:

- Compliance with the USB 2.0 specification
- Compliance with the Open HCI Rev 1.0 specification
- Supports both low speed (1.5 Mbps) and full speed (12 Mbps) USB device connections
- Root HUB integrated with 3 downstream USB ports
- Transceiver buffers integrated, over-current protection on ports
- Supports power management
- Operates as a master on the bus

The Open HCI host controller initializes the master DMA transfer with the AHB bus:

- Fetches endpoint descriptors and transfer descriptors
- Accesses endpoint data from system memory
- Accesses the HC communication area
- Writes status and retire transfer descriptor

**Table I. Triple Port USB Host Pin Assignments**

| Pin Mnemonic | Pin Name - Description |
|--------------|------------------------|
| USBp[2:0]    | USB Positive signals   |
| USBm[2:0]    | USB Negative Signals   |

## Two-Wire Interface With EEPROM Support

The two-wire interface provides communication and control for EEPROM devices.

**Table J. Two-Wire Port with EEPROM Support Pin Assignments**

| Pin Mnemonic | Pin Name - Description            | Alternative Usage   |
|--------------|-----------------------------------|---------------------|
| EECLK        | EEPROM / Two-Wire Interface Clock | General Purpose I/O |
| EEDATA       | EEPROM / Two-Wire Interface Data  | General Purpose I/O |
| SLA[0]       | External Power Switch Control     | General Purpose I/O |

## Real-Time Clock with Software Trim

The software trim feature on the real time clock (RTC) provides software controlled digital compensation of the 32.768 KHz crystal oscillator. This compensation is accurate to  $\pm 1.24$  sec/month.

Table K. Real-Time Clock with Pin Assignments

| Pin Mnemonic | Pin Name - Description            |
|--------------|-----------------------------------|
| RTCXTALI     | Real-Time Clock Oscillator Input  |
| RTCXTALO     | Real-Time Clock Oscillator Output |

## PLL and Clocking

The Processor and the Peripheral Clocks operate from a single 14.7456 MHz crystal.

The Real Time Clock operates from a 32.768 KHz crystal oscillator.

Table L. PLL and Clocking Pin Assignments

| Pin Mnemonic | Pin Name - Description |
|--------------|------------------------|
| XTALI        | Main Oscillator Input  |
| XTALO        | Main Oscillator Output |
| VDD_PLL      | Main Oscillator Power  |
| GND_PLL      | Main Oscillator Ground |

## Timers

The Watchdog Timer insures proper operation by requiring periodic attention to prevent a reset-on-time-out.

Two 16-bit timers operate as free running down-counters or as periodic timers for fixed interval interrupts and have a range of 0.03 ms to 4.27 seconds.

One 32-bit timer, plus a 6-bit prescale counter, has a range of 0.03  $\mu$ s to 73.3 hours.

One 40-bit debug timer, plus a 6-bit prescale counter, has a range of 1.0  $\mu$ s to 12.7 days.

## Interrupt Controller

The interrupt controller allows up to 62 interrupts to generate an Interrupt Request (IRQ) or Fast Interrupt Request (FIQ) signal to the processor core. Thirty-two hardware priority assignments are provided for assisting IRQ vectoring, and two levels are provided for FIQ vectoring. This allows time critical interrupts to be processed in the shortest time possible. Internal interrupts may be programmed as active high or active low level sensitive inputs. GPIO pins programmed as interrupts may be programmed as active high level

sensitive, active low level sensitive, rising edge triggered, falling edge triggered, or combined rising/falling edge triggered.

- Supports 64 interrupts from a variety of sources (such as UARTs, GPIO, and key matrix)
- Routes interrupt sources to either the ARM920T's IRQ or FIQ (Fast IRQ) inputs
- Three dedicated off-chip interrupt lines operate as active high level sensitive interrupts
- Any of the 16 GPIO lines maybe configured to generate interrupts
- Software supported priority mask for all FIQs and IRQs

Table M. Interrupt Controller Pin Assignment

| Pin Mnemonic | Pin Name - Description      |
|--------------|-----------------------------|
| INT[2:0]     | External Interrupts 2, 1, 0 |

## Dual LED Drivers

Two pins are assigned specifically to drive external LEDs.

Table N. Dual LED Pin Assignments

| Pin Mnemonic | Pin Name - Description | Alternative Usage   |
|--------------|------------------------|---------------------|
| GRLED        | Green LED              | General Purpose I/O |
| REDLED       | Red LED                | General Purpose I/O |

## General Purpose Input/Output (GPIO)

The 14 EGPIO pins may each be configured individually as an output, an input, or an interrupt input.

There are 22 pins that may alternatively be used as input, output, or open-drain pins, but do not support interrupts. These pins are:

- Key Matrix ROW[7:0], COL[7:0]
- Ethernet MDIO
- Both LED Outputs
- EEPROM Clock and Data
- GGPIQ[2]
- HGPIQ[7:2]

6 pins may alternatively be used as inputs only:

- CTSn, DSRn/DCDn
- 4 Interrupt Lines

2 pins may alternatively be used as outputs only:

- RTSn
- ARSTn

**Table O. General Purpose Input/Output Pin Assignment**

| Pin Mnemonic                     | Pin Name - Description                                       |
|----------------------------------|--|
| EGPIO[15]<br>EGPIO[13:0]         | Expanded General Purpose Input / Output Pins with Interrupts |
| FGPIO[7]<br>FGPIO[5]<br>FGPIO[0] | Expanded General Purpose Input / Output Pins with Interrupts |

decrement, or stay at the same value. All DMA addresses are physical, not virtual addresses.

## Reset and Power Management

The chip may be reset through the PRSTn pin or through the open drain common reset pin, RSTOn.

Clocks are managed on a peripheral-by-peripheral basis and may be turned off to conserve power.

The processor clock is dynamically adjustable from 0 to 200 MHz (184 MHz for industrial conditions).

**Table P. Reset and Power Management Pin Assignments**

| Pin Mnemonic | Pin Name - Description   |
|--------------|--|
| PRSTn        | Power On Reset   |
| RSTOn        | User Reset In/Out – Open Drain – Preserves Real Time Clock value |

## Hardware Debug Interface

The JTAG interface allows use of ARM's Multi-ICE or other in-circuit emulators.

**Table Q. Hardware Debug Interface**

| Pin Mnemonic | Pin Name - Description |
|--------------|------------------------|
| TCK          | JTAG Clock             |
| TDI          | JTAG Data In           |
| TDO          | JTAG Data Out          |
| TMS          | JTAG Test Mode Select  |
| TRSTn        | JTAG Port Reset        |

## 12-Channel DMA Controller

The DMA module contains 12 separate DMA channels. These may be used for peripheral-to-memory or memory-to-peripheral access. Two of these are dedicated to memory-to-memory transfers. Each DMA channel is connected to the 16-bit DMA request bus.

The request bus is a collection of requests, Serial Audio and UARTs. Each DMA channel can be used independently or dedicated to any request signal. For each DMA channel, source and destination addressing can be independently programmed to increment,

## Electrical Specifications

### Absolute Maximum Ratings

(All grounds = 0 V, all voltages with respect to 0 V)

| Parameter                                      | Symbol  | Min  | Max      | Unit |
|--|---------|------|----------|------|
| Power Supplies                                 | RVDD    | -    | 3.96     | V    |
|  | CVDD    | -    | 2.16     | V    |
|  | VDD_PLL | -    | 2.16     | V    |
|  | VDD_ADC | -    | 3.96     | V    |
| Total Power Dissipation (Note 1)               |         | -    | 2        | W    |
| Input Current per Pin, DC (Except supply pins) |         | -    | ±10      | mA   |
| Output current per pin, DC                     |         | -    | ±50      | mA   |
| Digital Input voltage (Note 2)                 |         | -0.3 | RVDD+0.3 | V    |
| Storage temperature                            |         | -40  | +125     | °C   |

Note: 1. Includes all power generated due to AC and/or DC output loading.  
 2. The power supply pins are at maximum values listed in "Recommended Operating Conditions", below.  
 3. At ambient temperatures above 70° C, total power dissipation must be limited to less than 2.5 Watts.

WARNING: Operation beyond these limits may result in permanent damage to the device.  
 Normal operation is not guaranteed at these extremes.

### Recommended Operating Conditions

(All grounds = 0 V, all voltages with respect to 0 V)

| Parameter                                  | Symbol         | Min  | Typ  | Max  | Unit |
|--|----------------|------|------|------|------|
| Power Supplies                             | RVDD           | 3.0  | 3.3  | 3.6  | V    |
|  | CVDD           | 1.65 | 1.80 | 1.94 | V    |
|  | VDD_PLL        | 1.65 | 1.80 | 1.94 | V    |
|  | VDD_ADC        | 3.0  | 3.3  | 3.6  | V    |
| Operating Ambient Temperature - Commercial | T <sub>A</sub> | 0    | +25  | +70  | °C   |
| Operating Ambient Temperature - Industrial | T <sub>A</sub> | -40  | +25  | +85  | °C   |
| Processor Clock Speed - Commercial         | FCLK           | -    | -    | 200  | MHz  |
| Processor Clock Speed - Industrial         | FCLK           | -    | -    | 184  | MHz  |
| System Clock Speed - Commercial            | HCLK           | -    | -    | 100  | MHz  |
| System Clock Speed - Industrial            | HCLK           | -    | -    | 92   | MHz  |

## DC Characteristics

( $T_A = 0$  to  $70^\circ\text{C}$ ;  $CVDD = VDD\_PLL = 1.8$ ;  $RVDD = 3.3\text{ V}$ ;

All grounds =  $0\text{ V}$ ; all voltages with respect to  $0\text{ V}$  unless otherwise noted)

| Parameter                  |                          |          | Symbol   | Min                | Max                | Unit          |
|----------------------------|--------------------------|----------|----------|--------------------|--------------------|---------------|
| High level output voltage  | $I_{out} = -4\text{ mA}$ | (Note 4) | $V_{oh}$ | $0.85 \times RVDD$ | -                  | V             |
| Low level output voltage   | $I_{out} = 4\text{ mA}$  |          | $V_{ol}$ | -                  | $0.15 \times RVDD$ | V             |
| High level input voltage   |                          | (Note 5) | $V_{ih}$ | $0.65 \times RVDD$ | $VDD + 0.3$        | V             |
| Low level input voltage    |                          | (Note 5) | $V_{il}$ | $-0.3$             | $0.35 \times RVDD$ | V             |
| High level leakage current | $V_{in} = 3.3\text{ V}$  | (Note 5) | $I_{ih}$ | -                  | 10                 | $\mu\text{A}$ |
| Low level leakage current  | $V_{in} = 0$             | (Note 5) | $I_{il}$ | -                  | -10                | $\mu\text{A}$ |

| Parameter                            |                    | Min | Typ | Max | Unit |
|--------------------------------------|--------------------|-----|-----|-----|------|
| Power Supply Pins (Outputs Unloaded) |                    |     |     |     |      |
| Power Supply Current:                | CVDD/VDD_PLL Total | -   | 200 | -   | mA   |
|                                      | RVDD               | -   | 20  | -   | mA   |
| Low-Power Mode Supply Current        | CVDD/VDD_PLL Total | -   | 2.5 | -   | mA   |
|                                      | RVDD               | -   | 1.0 | -   | mA   |

Note: 4. For open drain pins, high level output voltage is dependent on the external load.

5. All inputs that do not include internal pull-ups or pull-downs, must be externally driven for proper operation (See Table S on page 44). If an input is not driven, it should be tied to power or ground, depending on the particular function. If an I/O pin is not driven and programmed as an input, it should be tied to power or ground through its own resistor.

## Timings

### Timing Diagram Conventions

This data sheet contains one or more timing diagrams. The following key explains the components used in these diagrams. Any variations are clearly labelled when they occur. Therefore, no additional meaning should be attached unless specifically stated.

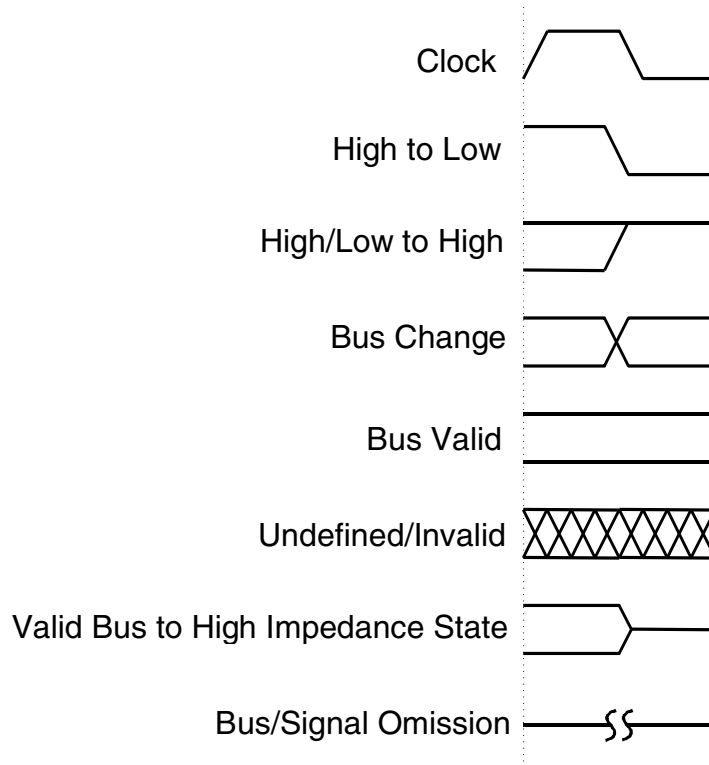

Figure 1. Timing Diagram Drawing Key

### Timing Conditions

Unless specified otherwise, the following conditions are true for all timing measurements.

- $T_A = 0$  to  $70^\circ\text{C}$
- $CVDD = VDD\_PLL = 1.8\text{V}$
- $RVDD = 3.3\text{V}$
- All grounds =  $0\text{V}$
- Logic 0 =  $0\text{V}$ , Logic 1 =  $3.3\text{V}$
- Output loading =  $50\text{pF}$
- Timing reference levels =  $1.5\text{V}$
- The Processor Bus Clock (HCLK) is programmable and is set by the user. The frequency is typically between  $33\text{MHz}$  and  $100\text{MHz}$  ( $92\text{MHz}$  for industrial conditions).

## Memory Interface

Figure 2 through Figure 5 define the timings associated with all phases of the SDRAM. The following table contains the values for the timings of each of the SDRAM modes.

| Parameter                                 | Symbol          | Min | Typ            | Max | Unit |
|---|-----------------|-----|----------------|-----|------|
| SDCLK high time                           | $t_{clk\_high}$ | -   | $(t_{HCLK})/2$ | -   | ns   |
| SDCLK low time                            | $t_{clk\_low}$  | -   | $(t_{HCLK})/2$ | -   | ns   |
| SDCLK rise/fall time                      | $t_{clkrf}$     | -   | 3              | -   | ns   |
| Signal delay from SDCLK rising edge time  | $t_d$           | -   | 8              | -   | ns   |
| Signal hold from SDCLK rising edge time   | $t_h$           | -   | 4              | -   | ns   |
| DQMn delay from SDCLK rising edge time    | $t_{DQd}$       | -   | 6              | -   | ns   |
| DQMn hold from SDCLK rising edge time     | $t_{DQh}$       | -   | 6              | -   | ns   |
| DA valid setup to SDCLK rising edge time  | $t_{DAs}$       | -   | 2              | -   | ns   |
| DA valid hold from SDCLK rising edge time | $t_{DAh}$       | -   | 2              | -   | ns   |

### SDRAM Load Mode Register Cycle

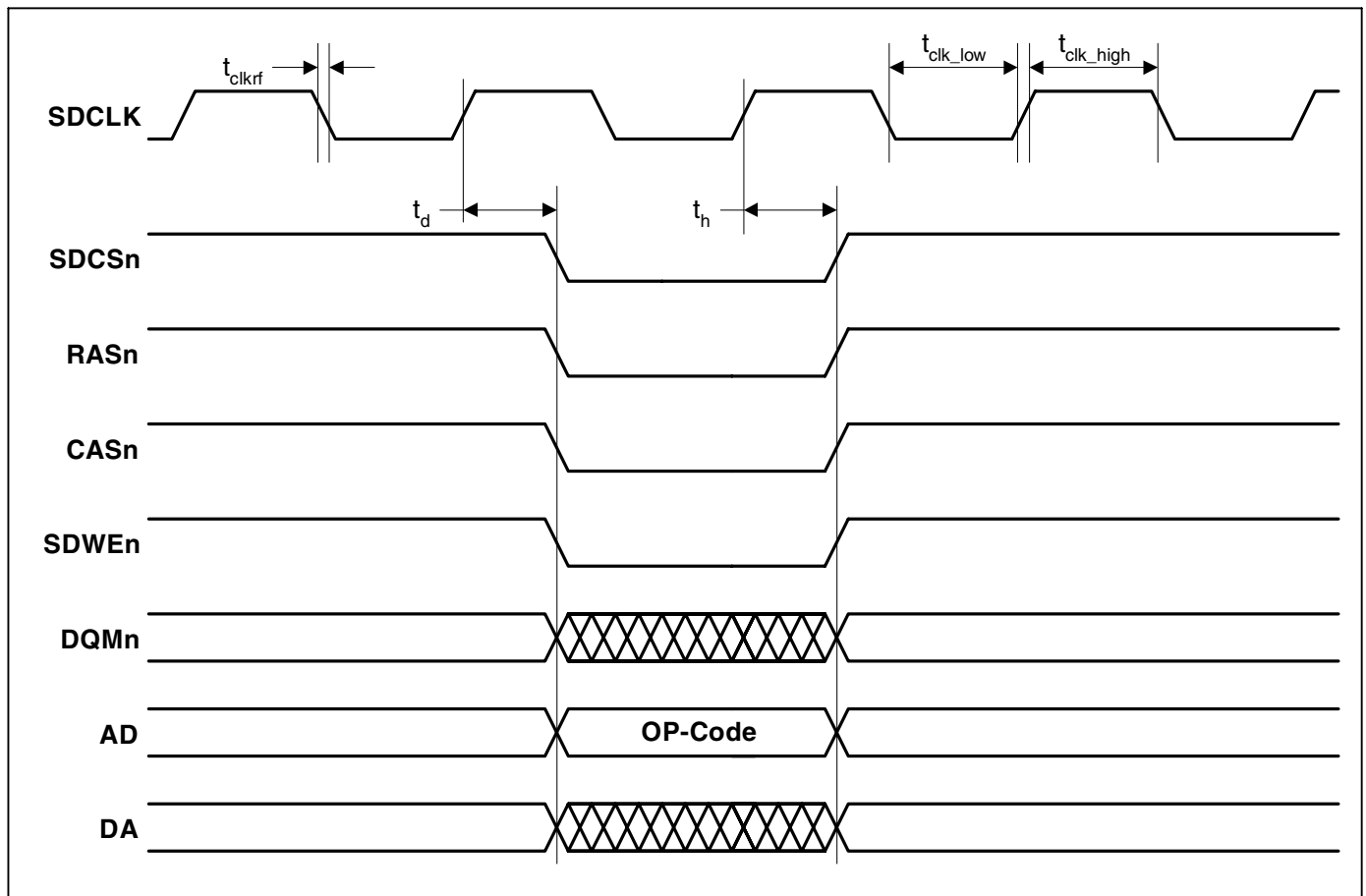

Figure 2. SDRAM Load Mode Register Cycle Timing Measurement

**SDRAM Burst Read Cycle**

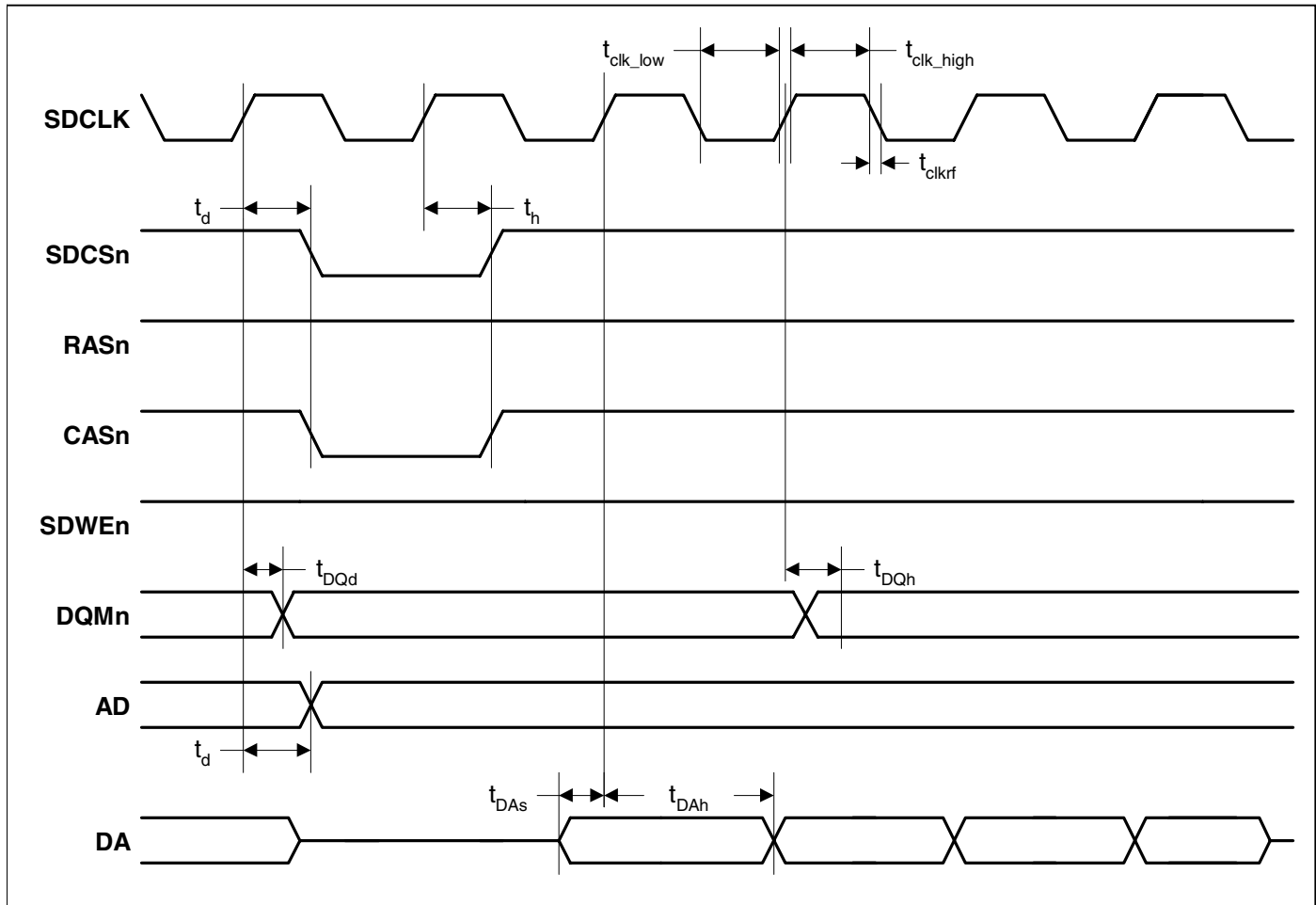

Figure 3. SDRAM Burst Read Cycle Timing Measurement

**SDRAM Burst Write Cycle**

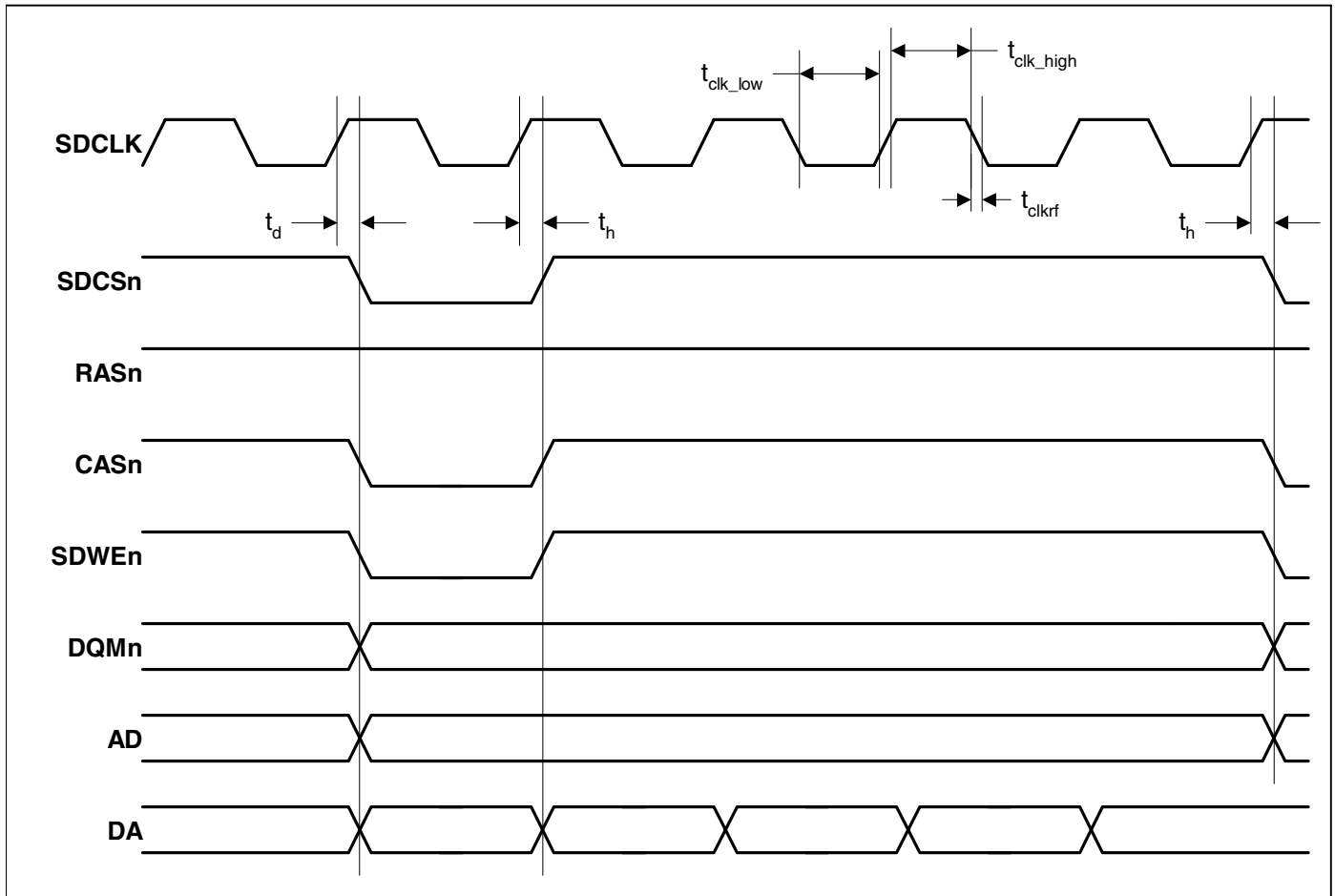
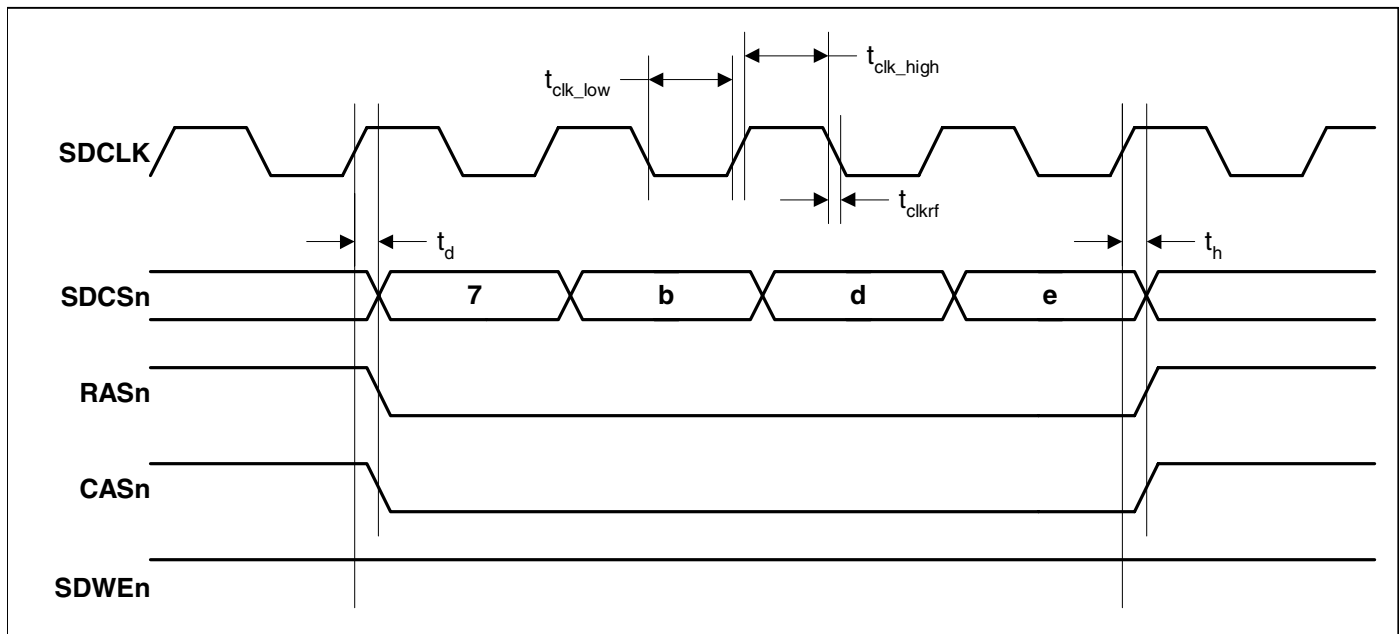

Figure 4. SDRAM Burst Write Cycle Timing Measurement

### SDRAM Auto Refresh Cycle



Note: Chip select shown as bus to illustrate multiple devices being put into auto refresh in one access

Figure 5. SDRAM Auto Refresh Cycle Timing Measurement

**Static Memory Single Word Read Cycle**

| Parameter                                | Symbol     | Min | Typ                          | Max                  | Unit |
|--|------------|-----|------------------------------|----------------------|------|
| AD setup to RDn assert time              | $t_{ADs}$  | -   | 5                            | -                    | ns   |
| AD hold from RDn deassert time           | $t_{ADh}$  | -   | $t_{HCLK} \times 2$          | -                    | ns   |
| RDn assert time                          | $t_{RDpw}$ | -   | $t_{HCLK} \times (WST1 + 2)$ | $t_{HCLK} \times 33$ | ns   |
| CSn assert to RDn assert delay time      | $t_{RDd}$  | -   | 0                            | -                    | ns   |
| CSn deassert to RDn deassert delay time  | $t_{RDh}$  | -   | 0                            | -                    | ns   |
| CSn assert to DQMn assert delay time     | $t_{DQMd}$ | -   | 0                            | -                    | ns   |
| CSn deassert to DQMn deassert delay time | $t_{DQMh}$ | -   | 0                            | -                    | ns   |
| DA setup to RDn deassert time            | $t_{DAs}$  | -   | $t_{HCLK} + 6$               | -                    | ns   |
| DA hold from RDn deassert time           | $t_{DAh}$  | 0   | 0                            | -                    | ns   |

See "Timing Conditions" on page 14 for definition of HCLK.

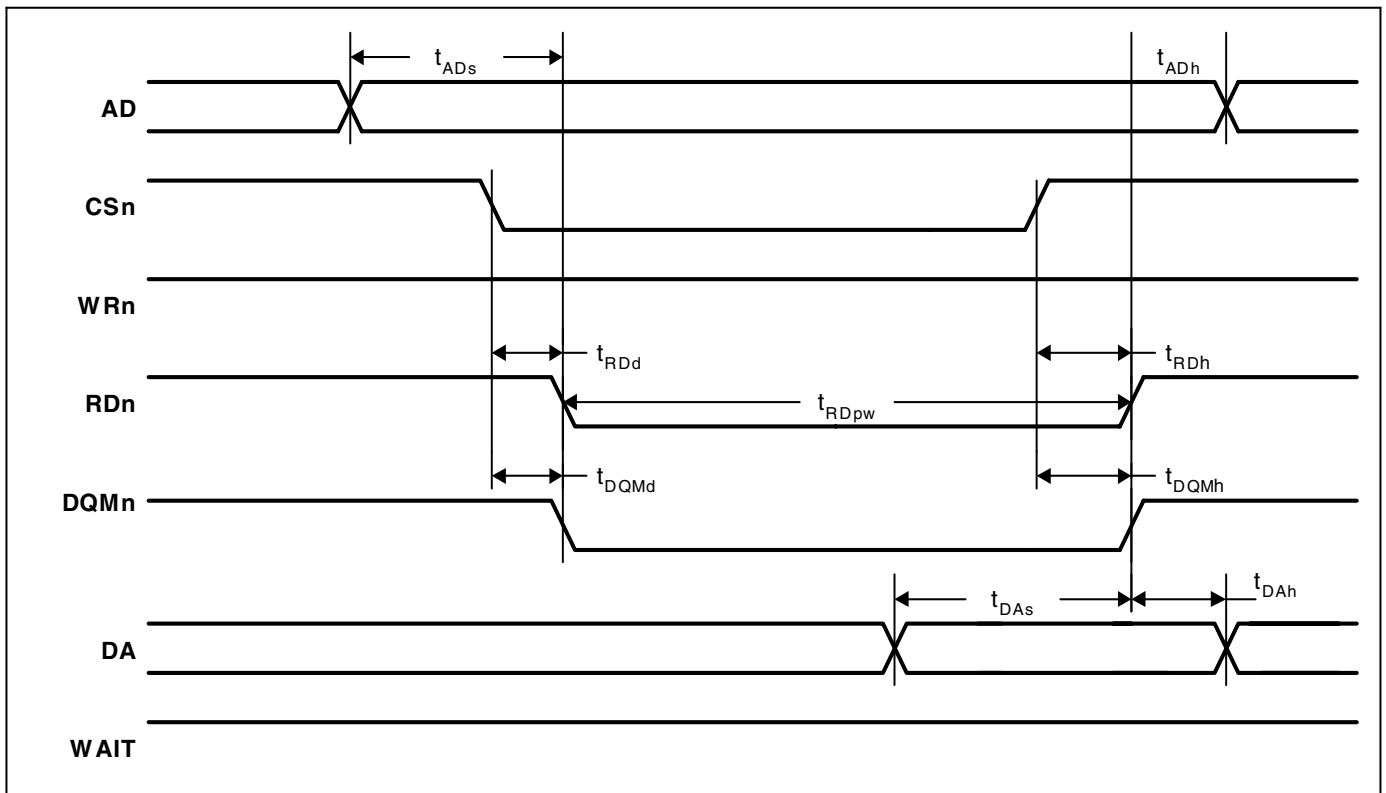

Figure 6. Static Memory Single Word Read Cycle Timing Measurement

### Static Memory Single Word Write Cycle

| Parameter                          | Symbol     | Min | Typ                          | Max | Unit |
|------------------------------------|------------|-----|------------------------------|-----|------|
| AD setup to WRn assert time        | $t_{ADs}$  | -   | $t_{HCLK}$                   | -   | ns   |
| AD hold from WRn deassert time     | $t_{ADh}$  | -   | $t_{HCLK} \times 3$          | -   | ns   |
| WRn deassert to CSn deassert time  | $t_{CSh}$  | -   | $t_{HCLK}$                   | -   | ns   |
| CSn to WRn assert delay time       | $t_{WRd}$  | -   | 0                            | -   | ns   |
| WRn assert time                    | $t_{WRpw}$ | -   | $t_{HCLK} \times (WST1 + 1)$ | -   | ns   |
| CSn to DQMn assert delay time      | $t_{DQMd}$ | -   | 0                            | -   | ns   |
| WRn deassert to DQMn deassert time | $t_{DQMh}$ | -   | 0                            | -   | ns   |
| WRn deassert to DA transition time | $t_{DAh}$  | -   | $t_{HCLK}$                   | -   | ns   |

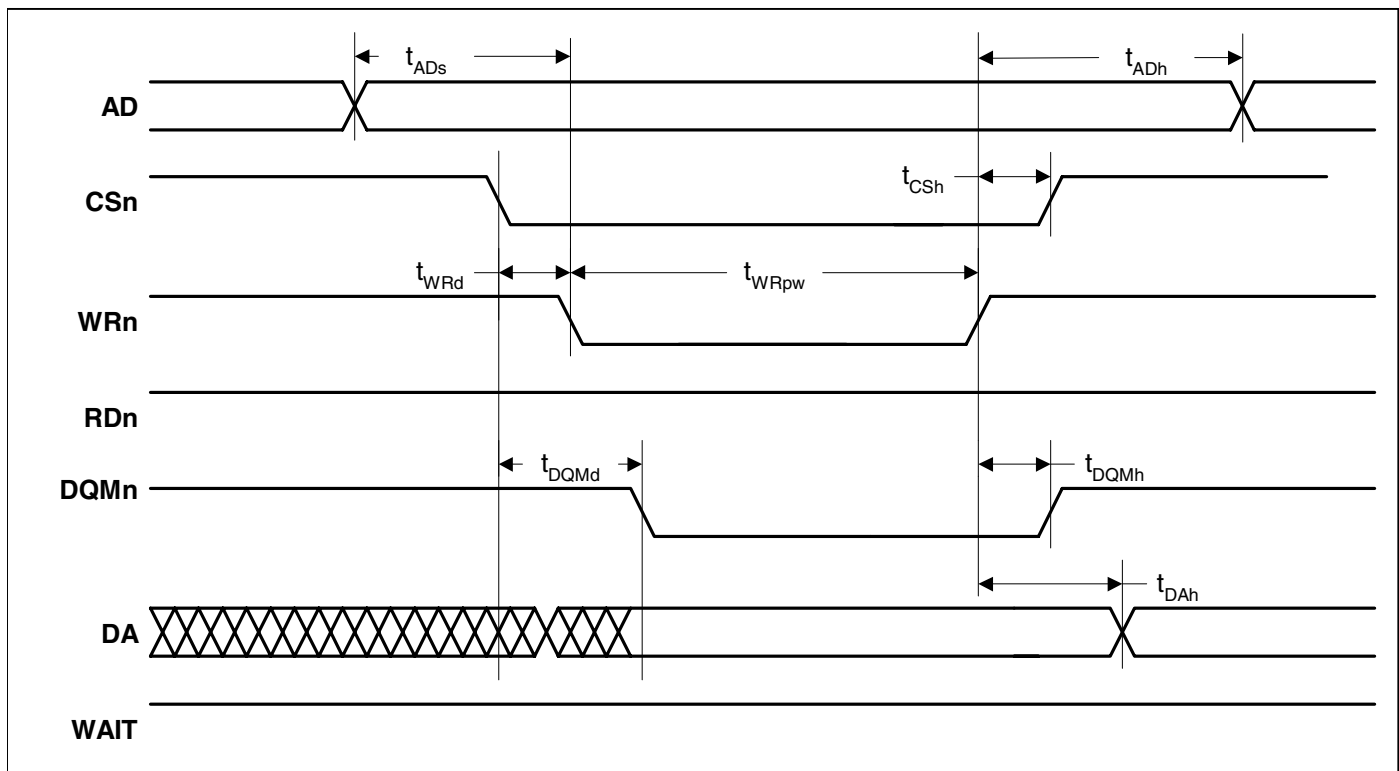
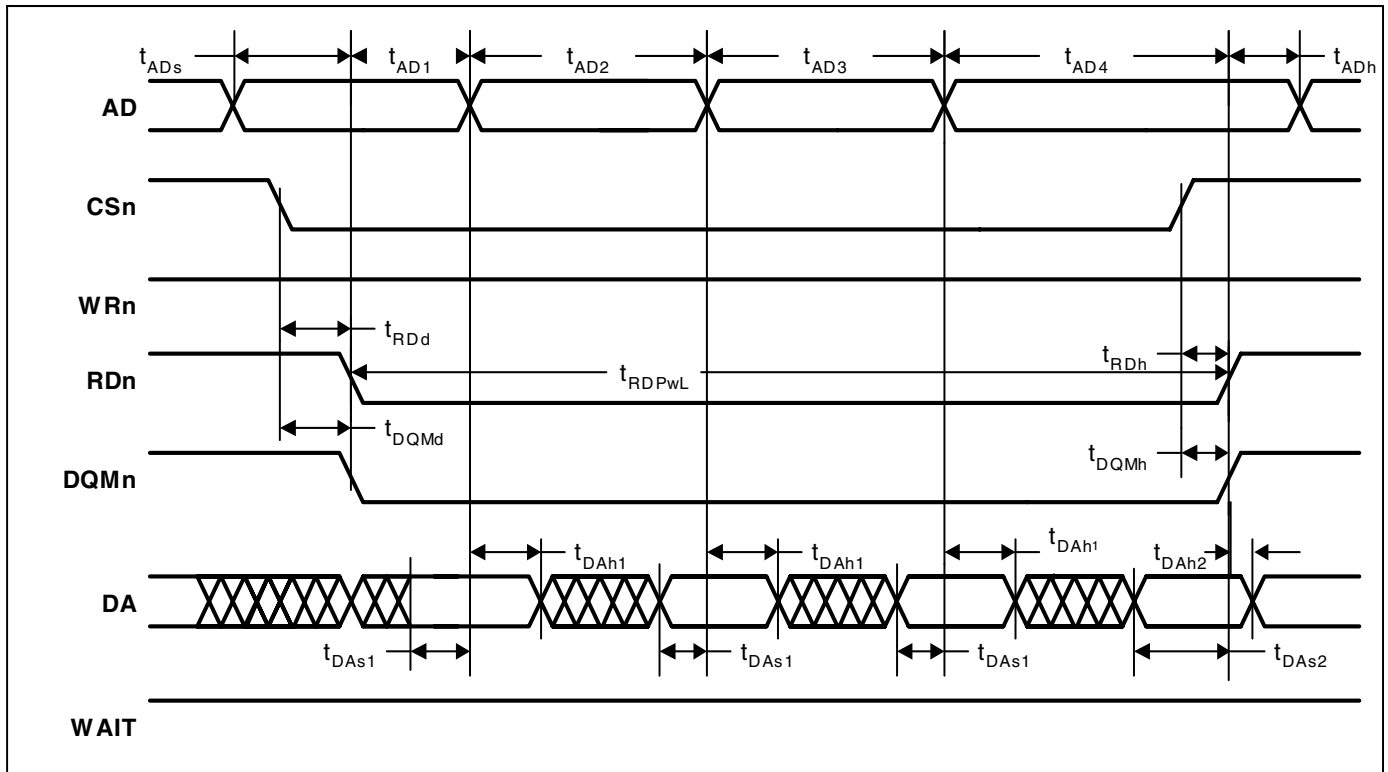

Figure 7. Static Memory Single Word Write Cycle Timing Measurement

**Static Memory 32-bit Read on 8-bit External Bus**

| Parameter                                | Symbol      | Min | Typ                                   | Max | Unit |
|--|-------------|-----|---------------------------------------|-----|------|
| AD setup to RDn assert time              | $t_{ADs}$   | -   | $t_{HCLK}$                            | -   | ns   |
| RDn assert to Address 1 transition time  | $t_{AD1}$   | -   | $t_{HCLK} \times (WST1 + 1)$          | -   | ns   |
| Address 2 assert time                    | $t_{AD2}$   | -   | $t_{HCLK} \times (WST1 + 1)$          | -   | ns   |
| Address 3 assert time                    | $t_{AD3}$   | -   | $t_{HCLK} \times (WST1 + 1)$          | -   | ns   |
| AD transition to RDn deassert time       | $t_{AD4}$   | -   | $t_{HCLK} \times (WST1 + 2)$          | -   | ns   |
| AD hold from RDn deassert time           | $t_{ADh}$   | -   | $t_{HCLK} \times 2$                   | -   | ns   |
| RDn assert time                          | $t_{RDpWL}$ | -   | $t_{HCLK} \times (4 \times WST1 + 5)$ | -   | ns   |
| CSn assert to RDn assert delay time      | $t_{RDd}$   | -   | 0                                     | -   | ns   |
| CSn deassert to RDn deassert delay time  | $t_{RDh}$   | -   | 0                                     | -   | ns   |
| CSn assert to DQMn assert delay time     | $t_{DQMd}$  | -   | 0                                     | -   | ns   |
| CSn deassert to DQMn deassert delay time | $t_{DQMh}$  | -   | 0                                     | -   | ns   |
| DA setup to AD transition time           | $t_{DAs1}$  | -   | 6                                     | -   | ns   |
| DA to RDn setup time                     | $t_{DAs2}$  | -   | $t_{HCLK} + 6$                        | -   | ns   |
| AD transition to DA transition hold time | $t_{DAh1}$  | -   | 0                                     | -   | ns   |
| RDn deassert to DA transition hold time  | $t_{DAh2}$  | -   | 0                                     | -   | ns   |

**Figure 8. Static Memory Multiple Word Read 8 Bit Cycle Timing Measurement**

**Static Memory 32-bit Write on 8-bit External Bus**

| Parameter                               | Symbol       | Min | Typ                          | Max | Unit |
|---|--------------|-----|------------------------------|-----|------|
| AD setup to WRn assert time             | $t_{ADs}$    | -   | $t_{HCLK}$                   | -   | ns   |
| WRn deassert to AD transition time      | $t_{ADd}$    | -   | $t_{HCLK}$                   | -   | ns   |
| AD hold from WRn deassert time          | $t_{ADh}$    | -   | $t_{HCLK} \times 3$          | -   | ns   |
| CSn hold from WRn deassert time         | $t_{CSH}$    | -   | $t_{HCLK}$                   | -   | ns   |
| CSn to WRn assert delay time            | $t_{WRd}$    | -   | 0                            | -   | ns   |
| WRn assert time                         | $t_{WRpwL}$  | -   | $t_{HCLK} \times (WST1 + 1)$ | -   | ns   |
| WRn deassert time                       | $t_{WRpwH}$  | -   | $t_{HCLK} \times 2$          | -   | ns   |
| CSn to DQMn assert delay time           | $t_{DQMd}$   | -   | 0                            | -   | ns   |
| DQMn assert time                        | $t_{DQMpwL}$ | -   | $t_{HCLK} \times (WST1 + 1)$ | -   | ns   |
| DQMn deassert time                      | $t_{DQMpwH}$ | -   | $t_{HCLK} \times 2$          | -   | ns   |
| WRn/DQMn deassert to DA transition time | $t_{DAh}$    | -   | $t_{HCLK}$                   | -   | ns   |

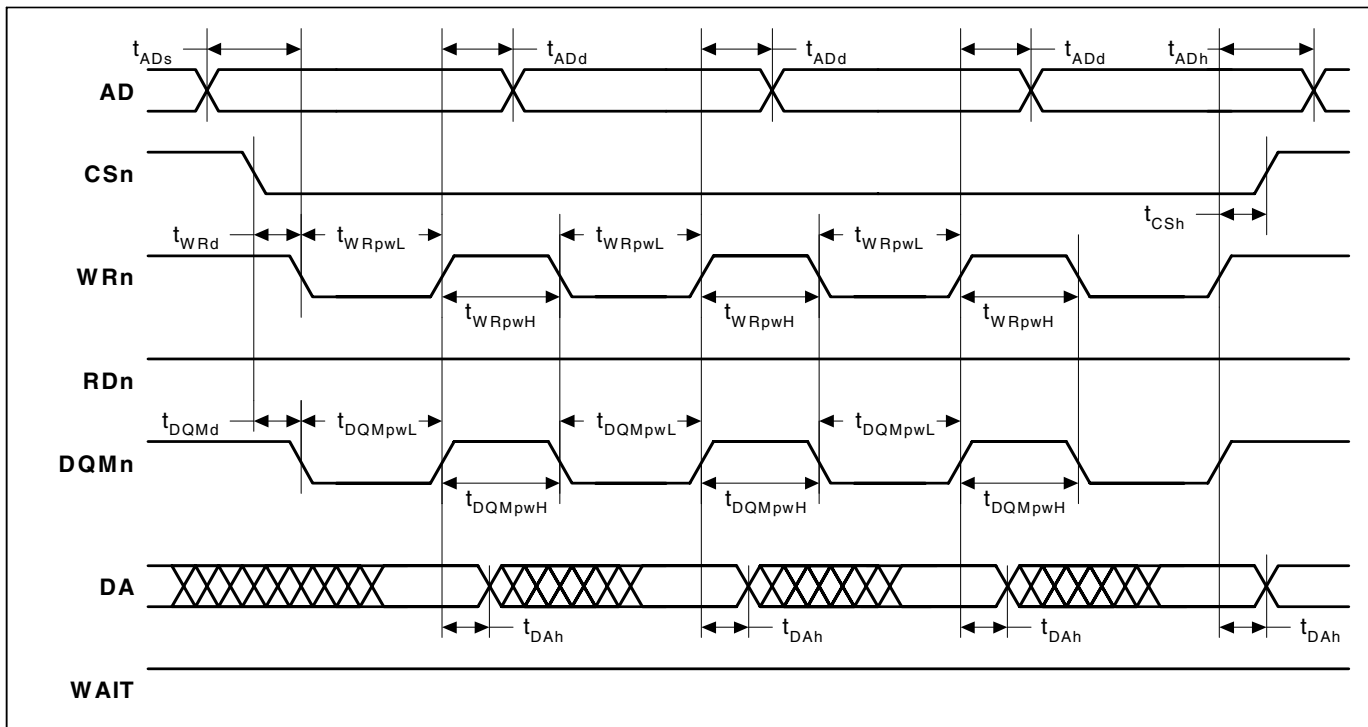
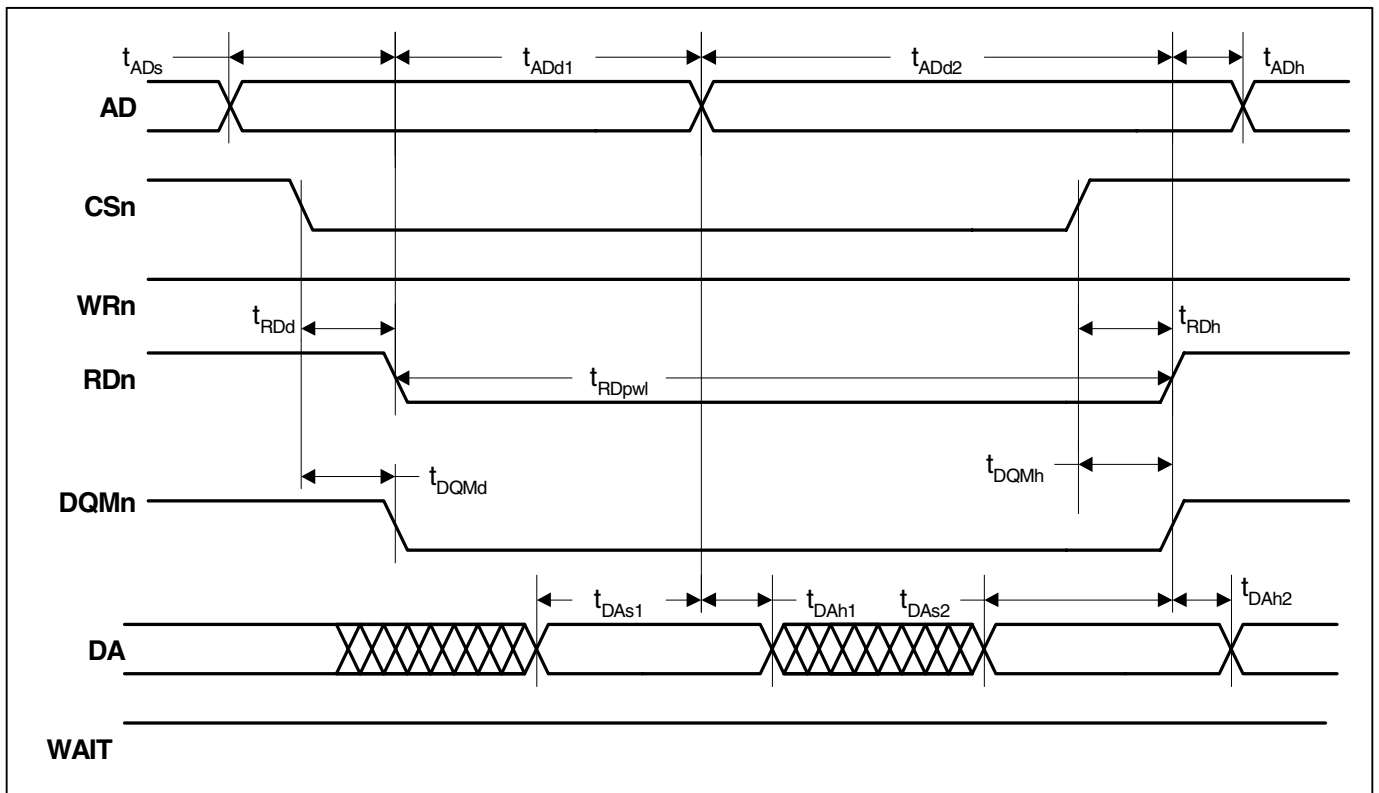

Figure 9. Static Memory Multiple Word Write 8 bit Cycle Timing Measurement

**Static Memory 32-bit Read on 16-bit External Bus**

| Parameter                                | Symbol      | Min | Typ                                   | Max | Unit |
|--|-------------|-----|---------------------------------------|-----|------|
| AD setup to RDn assert time              | $t_{ADs}$   | -   | $t_{HCLK}$                            | -   | ns   |
| RDn assert to AD transition time         | $t_{ADd1}$  | -   | $t_{HCLK} \times (WST1 + 1)$          | -   | ns   |
| AD transition to RDn deassert time       | $t_{ADd2}$  | -   | $t_{HCLK} \times (WST1 + 2)$          | -   | ns   |
| AD hold from RDn deassert time           | $t_{ADh}$   | -   | $t_{HCLK} \times 2$                   | -   | ns   |
| RDn assert time                          | $t_{RDpwl}$ | -   | $t_{HCLK} \times (2 \times WST1 + 3)$ | -   | ns   |
| CSn to RDn assert delay time             | $t_{RDd}$   | -   | 0                                     | -   | ns   |
| CSn to RDn deassert delay time           | $t_{RDh}$   | -   | 0                                     | -   | ns   |
| CSn to DQMn assert delay time            | $t_{DQMd}$  | -   | 0                                     | -   | ns   |
| CSn to DQMn deassert delay time          | $t_{DQMh}$  | -   | 0                                     | -   | ns   |
| DA to ADsetup time                       | $t_{DAs1}$  | -   | 6                                     | -   | ns   |
| DA to RDn setup time                     | $t_{DAs2}$  | -   | $t_{HCLK} + 6$                        | -   | ns   |
| AD transition to DA transition hold time | $t_{DAh1}$  | -   | 0                                     | -   | ns   |
| RDn deassert to DA transition hold time  | $t_{DAh2}$  | -   | 0                                     | -   | ns   |

**Figure 10. Static Memory Multiple Word Read 16 Bit Cycle Timing Measurement**

**Static Memory 32-bit Write on 16-bit External Bus**

| Parameter                               | Symbol       | Min | Typ                          | Max | Unit |
|---|--------------|-----|------------------------------|-----|------|
| AD setup to WRn assert time             | $t_{ADs}$    | -   | $t_{HCLK}$                   | -   | ns   |
| WRn deassert to AD transition time      | $t_{ADd}$    | -   | $t_{HCLK}$                   | -   | ns   |
| AD hold from WRn deassert time          | $t_{ADh}$    | -   | $2 \times t_{HCLK}$          | -   | ns   |
| CSn hold from WRn deassert time         | $t_{CSh}$    | -   | $t_{HCLK}$                   | -   | ns   |
| CSn to WRn assert delay time            | $t_{WRd}$    | -   | 0                            | -   | ns   |
| WRn assert time                         | $t_{WRpwL}$  | -   | $t_{HCLK} \times (WST1 + 1)$ | -   | ns   |
| WRn deassert time                       | $t_{WRpwH}$  | -   | $t_{HCLK} \times 2$          | -   | ns   |
| CSn to DQMn assert delay time           | $t_{DQMd}$   | -   | 0                            | -   | ns   |
| DQMn assert time                        | $t_{DQmpwL}$ | -   | $t_{HCLK} \times (WST1 + 1)$ | -   | ns   |
| DQMn deassert time                      | $t_{DQmpwH}$ | -   | $t_{HCLK} \times 2$          | -   | ns   |
| WRn/DQMn deassert to DA transition time | $t_{DAh1}$   | -   | $t_{HCLK}$                   | -   | ns   |
| WRn/DQMn deassert to DA transition time | $t_{DAh2}$   | -   | $t_{HCLK}$                   | -   | ns   |

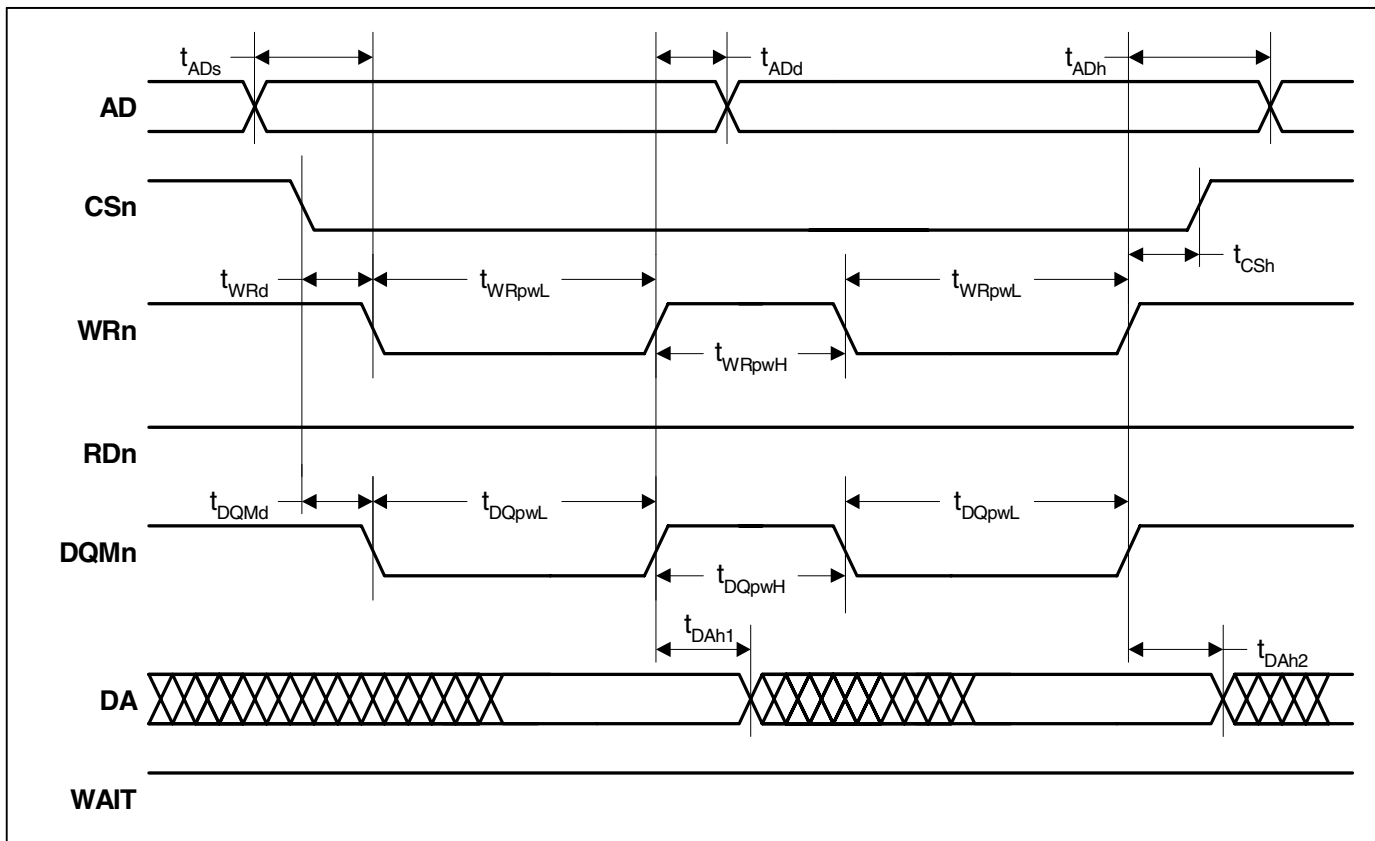

Figure 11. Static Memory Multiple Word Write 16 bit Cycle Timing Measurement

**Static Memory Burst Read Cycle**

| Parameter                                | Symbol      | Min | Typ  | Max | Unit |
|--|-------------|-----|--|-----|------|
| CSn assert to Address 1 transition time  | $t_{ADd1}$  | -   | $t_{HCLK} \times (WST1 + 1)$                 | -   | ns   |
| Address 2 assert time                    | $t_{ADd2}$  | -   | $t_{HCLK} \times (WST2 + 1)$                 | -   | ns   |
| AD hold from CSn deassert time           | $t_{ADh}$   | -   | $t_{HCLK} \times 2$                          | -   | ns   |
| CSn assert time                          | $t_{CSpw}$  | -   | $t_{HCLK} \times ((WST1 + 1) + 4(WST2 + 1))$ | -   | ns   |
| CSn to RDn assert delay time             | $t_{RDd}$   | -   | 0  | -   | ns   |
| RDn assert time                          | $t_{RDpw}$  | -   | $t_{HCLK} \times ((WST1 + 1) + 4(WST2 + 1))$ | -   | ns   |
| CSn to DQMn assert delay time            | $t_{DQMd}$  | -   | 4  | -   | ns   |
| DQMn assert time                         | $t_{DQMpw}$ | -   | $t_{HCLK} \times ((WST1 + 1) + 4(WST2 + 1))$ | -   | ns   |
| DA to AD setup time                      | $t_{DAs1}$  | -   | 6  | -   | ns   |
| DA to CSn setup time                     | $t_{DAs2}$  | -   | $t_{HCLK} + 6$                               | -   | ns   |
| AD transition to DA transition hold time | $t_{DAh1}$  | -   | 0  | -   | ns   |
| CSn deassert to DA transition hold time  | $t_{DAh2}$  | 0   | 0  | -   | ns   |

Note: These characteristics are valid when the Page Mode Enable (Burst Mode) bit is set. See the User's Guide for details.

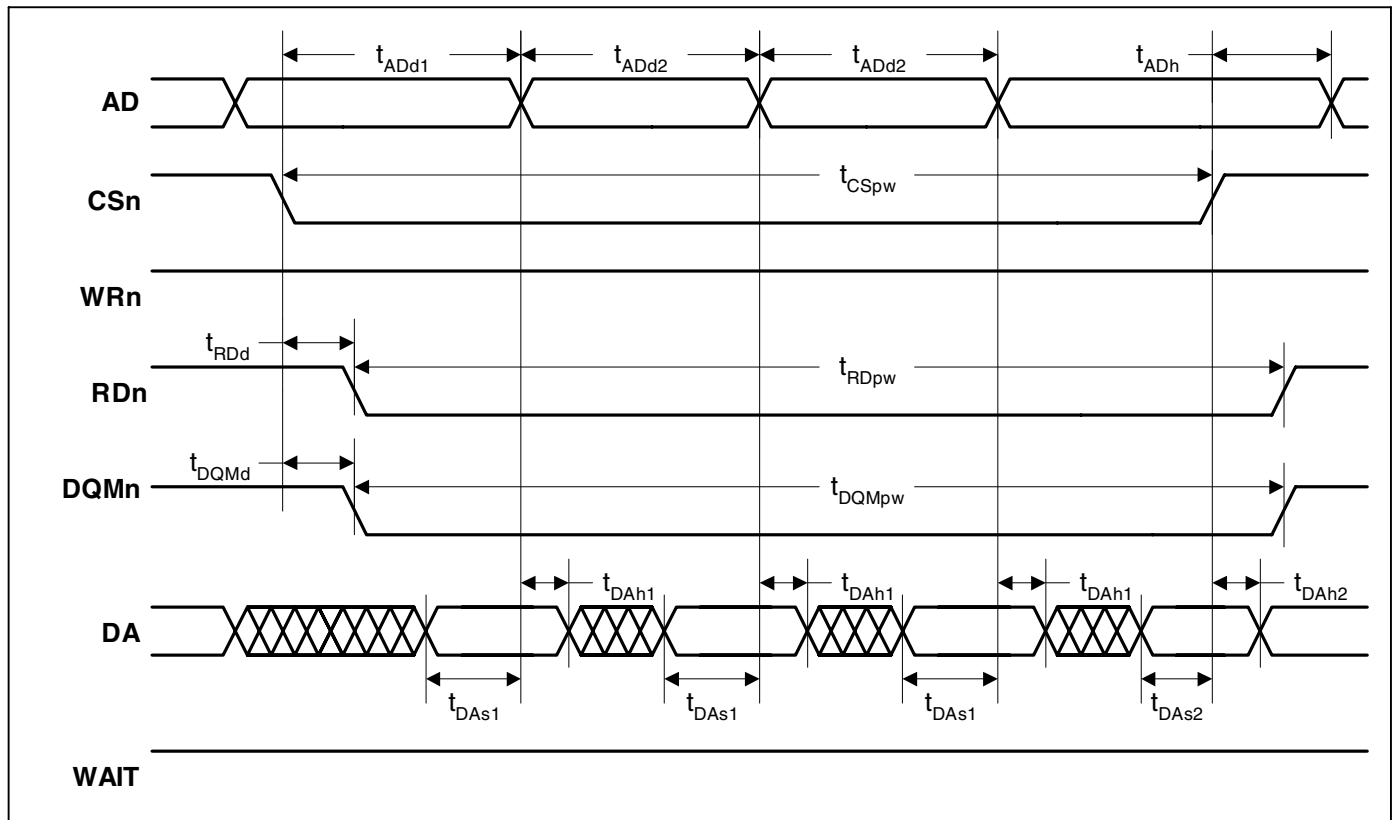

Figure 12. Static Memory Burst Read Cycle Timing Measurement

### Static Memory Single Read Wait Cycle

| Parameter                       | Symbol       | Min                 | Typ | Max                          | Unit |
|---------------------------------|--------------|---------------------|-----|------------------------------|------|
| CSn assert to WAIT time         | $t_{WAITd}$  | -                   | -   | $t_{HCLK} \times (WST1 - 2)$ | ns   |
| WAIT assert time                | $t_{WAITpw}$ | $t_{HCLK} \times 2$ | -   | $t_{HCLK} \times 510$        | ns   |
| WAIT to CSn deassert delay time | $t_{CSnd}$   | $t_{HCLK} \times 3$ | -   | $t_{HCLK} \times 5$          | ns   |

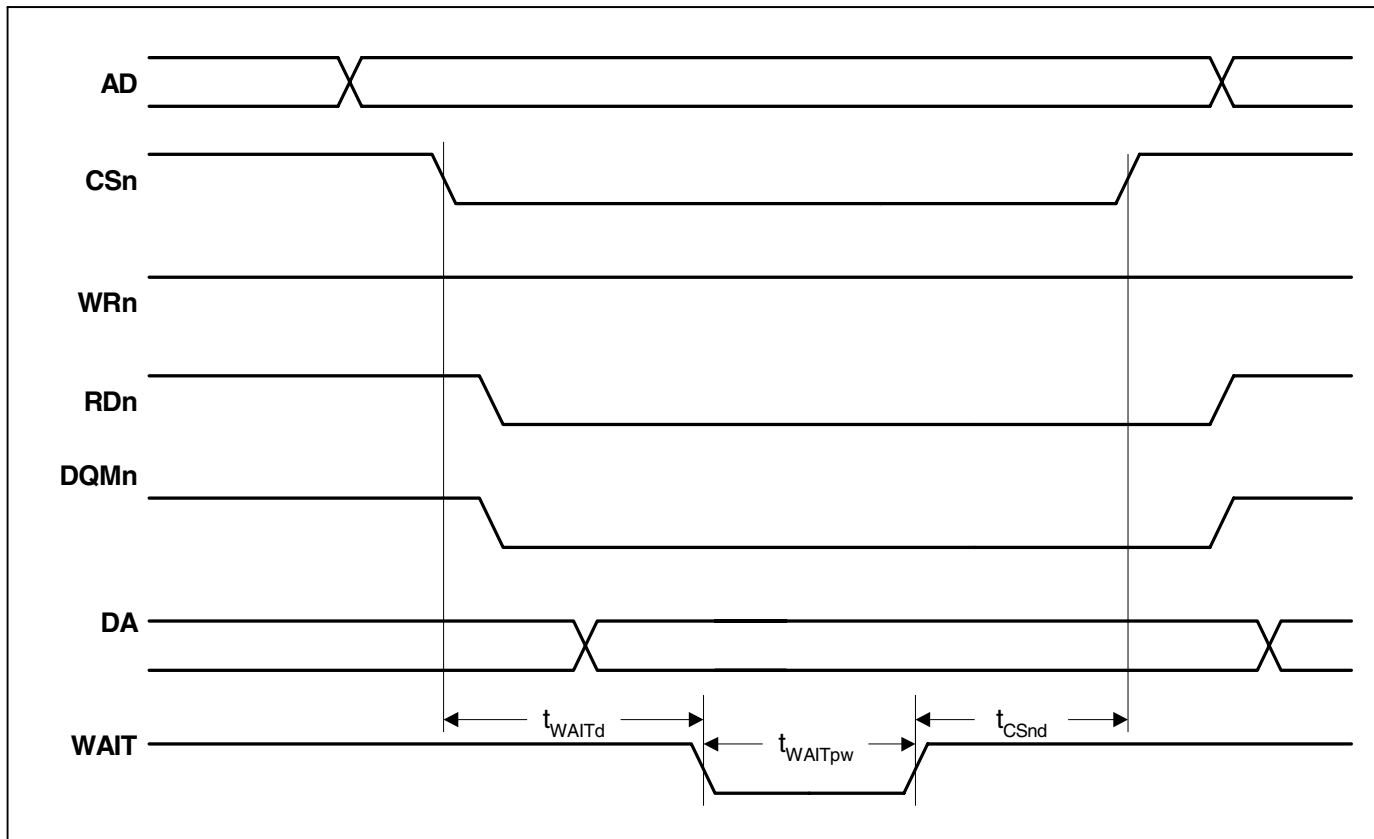
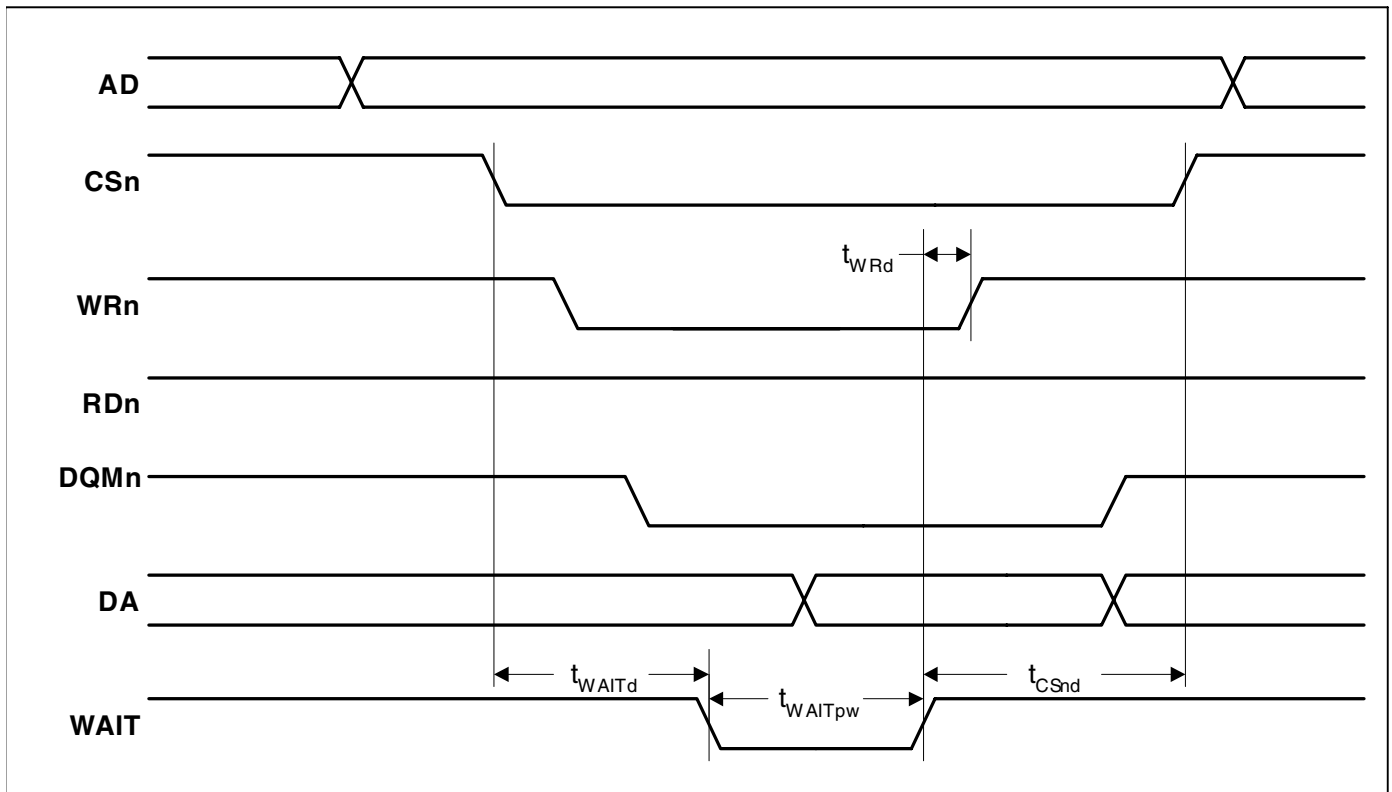

Figure 13. Static Memory Single Read Wait Cycle Timing Measurement

**Static Memory Single Write Wait Cycle**

| Parameter                       | Symbol       | Min                 | Typ | Max                          | Unit |
|---------------------------------|--------------|---------------------|-----|------------------------------|------|
| WAIT to WRn deassert delay time | $t_{WRd}$    | $t_{HCLK} \times 2$ | -   | $t_{HCLK} \times 4$          | ns   |
| CSn assert to WAIT time         | $t_{WAITd}$  | -                   | -   | $t_{HCLK} \times (WST1 - 2)$ | ns   |
| WAIT assert time                | $t_{WAITpw}$ | $t_{HCLK} \times 2$ | -   | $t_{HCLK} \times 510$        | ns   |
| WAIT to CSn deassert delay time | $t_{CSnd}$   | $t_{HCLK} \times 3$ | -   | $t_{HCLK} \times 5$          | ns   |

**Figure 14. Static Memory Single Write Wait Cycle Timing Measurement**

### Static Memory Turnaround Cycle

| Parameter                         | Symbol      | Min | Typ                        | Max | Unit |
|-----------------------------------|-------------|-----|----------------------------|-----|------|
| CSnX deassert to CSnY assert time | $t_{BTcyc}$ | -   | $t_{HCLK} \times (IDCY+1)$ | -   | ns   |

Note: X and Y represent any two chip select numbers.

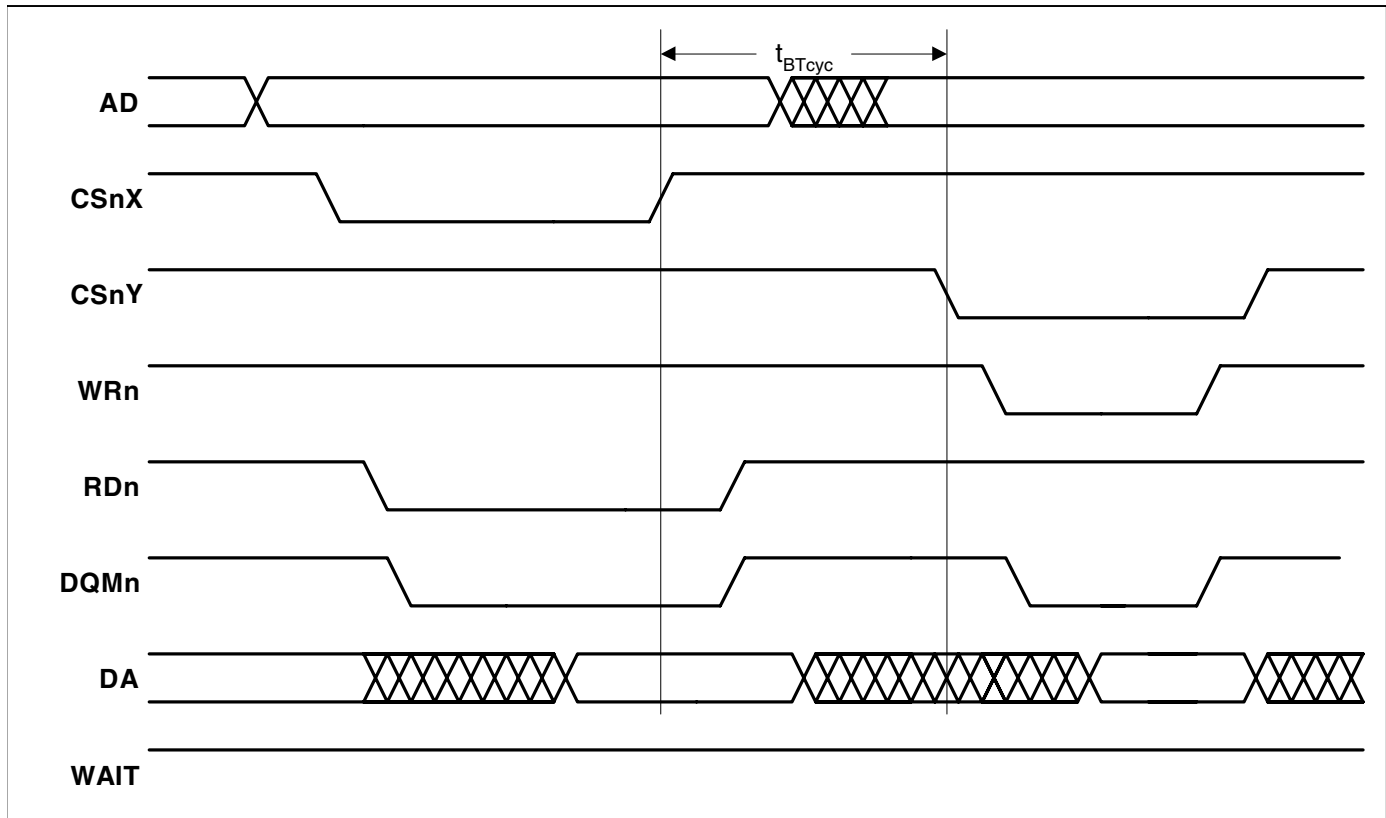

Figure 15. Static Memory Turnaround Cycle Timing Measurement

## Ethernet MAC Interface

| Parameter  | Symbol          | Min          |               | Typ          |               | Max          |               | Unit |
|--|-----------------|--------------|---------------|--------------|---------------|--------------|---------------|------|
|  |                 | 10 Mbit mode | 100 Mbit mode | 10 Mbit mode | 100 Mbit mode | 10 Mbit mode | 100 Mbit mode |      |
| TXCLK cycle time                                       | $t_{TX\_per}$   | -            | -             | 400          | 40            | -            | -             | ns   |
| TXCLK high time  | $t_{TX\_high}$  | 140          | 14            | 200          | 20            | 260          | 26            | ns   |
| TXCLK low time   | $t_{TX\_low}$   | 140          | 14            | 200          | 20            | 260          | 26            | ns   |
| TXCLK to signal transition delay time                  | $t_{TXd}$       | 0            | 0             | 10           | 10            | 25           | 25            | ns   |
| TXCLK rise/fall time                                   | $t_{TXrf}$      | -            | -             | -            | -             | 5            | 5             | ns   |
| RXCLK cycle time                                       | $t_{RX\_per}$   | -            | -             | 400          | 40            | -            | -             | ns   |
| RXCLK high time  | $t_{RX\_high}$  | 140          | 14            | 200          | 20            | 260          | 26            | ns   |
| RXCLK low time   | $t_{RX\_low}$   | 140          | 14            | 200          | 20            | 260          | 26            | ns   |
| RXDVAL/RXERR setup time                                | $t_{RXs}$       | 10           | 10            | -            | -             | -            | -             | ns   |
| RXDVAL/RXERR hold time                                 | $t_{RXh}$       | 10           | 10            | -            | -             | -            | -             | ns   |
| RXCLK rise/fall time                                   | $t_{RXrf}$      | -            | -             | -            | -             | 5            | 5             | ns   |
| MDC cycle time   | $t_{MDC\_per}$  | 400          | 400           | -            | -             | -            | -             | ns   |
| MDC high time  | $t_{MDC\_high}$ | 160          | 160           | -            | -             | -            | -             | ns   |
| MDC low time   | $t_{MDC\_low}$  | 160          | 160           | -            | -             | -            | -             | ns   |
| MDC rise/fall time                                     | $t_{MDCrf}$     | -            | -             | -            | -             | 5            | 5             | ns   |
| MDIO setup time (STA sourced)                          | $t_{MDIOs}$     | 10           | 10            | 15           | 15            | -            | -             | ns   |
| MDIO hold time (STA sourced)                           | $t_{MDIOh}$     | 10           | 10            | 15           | 15            | -            | -             | ns   |
| MDC to MDIO signal transition delay time (PHY sourced) | $t_{MDIOd}$     | -            | -             | -            | -             | 300          | 300           | ns   |

STA - Station - Any device that contains an IEEE 802.11 conforming Medium Access Control (MAC) and physical layer (PHY) interface to the wireless medium.

PHY - Ethernet physical layer interface.

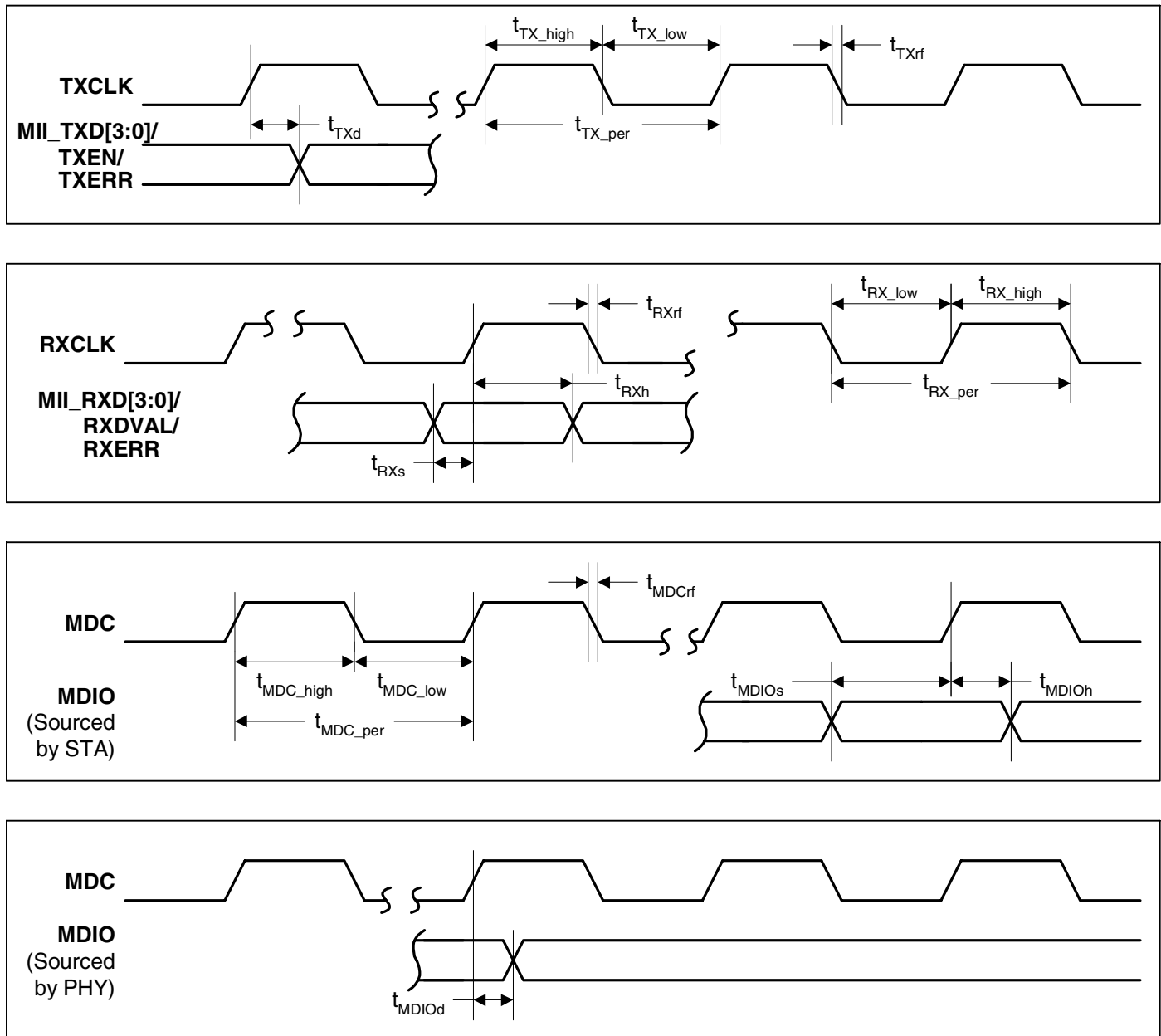

Figure 16. Ethernet MAC Timing Measurement

## Audio Interface

The following table contains the values for the timings of each of the SPI modes.

| Parameter                         | Symbol          | Min | Typ              | Max | Unit |
|-----------------------------------|-----------------|-----|------------------|-----|------|
| SCLK cycle time                   | $t_{clk\_per}$  | -   | $tspix\_clk$     | -   | ns   |
| SCLK high time                    | $t_{clk\_high}$ | -   | $(tspix\_clk)/2$ | -   | ns   |
| SCLK low time                     | $t_{clk\_low}$  | -   | $(tspix\_clk)/2$ | -   | ns   |
| SCLK rise/fall time               | $t_{clkrf}$     | -   | 4.5 / 1.5        | -   | ns   |
| Data from master valid delay time | $t_{DMd}$       | -   | 2                | -   | ns   |
| Data from master setup time       | $t_{DMs}$       | -   | 20               | -   | ns   |
| Data from master hold time        | $t_{DMh}$       | -   | 40               | -   | ns   |
| Data from slave valid delay time  | $t_{DSd}$       | -   | 2                | -   | ns   |
| Data from slave setup time        | $t_{DSs}$       | -   | 20               | -   | ns   |
| Data from slave hold time         | $t_{DSh}$       | -   | 40               | -   | ns   |

Note:  $tspix\_clk$  is programmable by the user.

**Texas Instruments' Synchronous Serial Format**

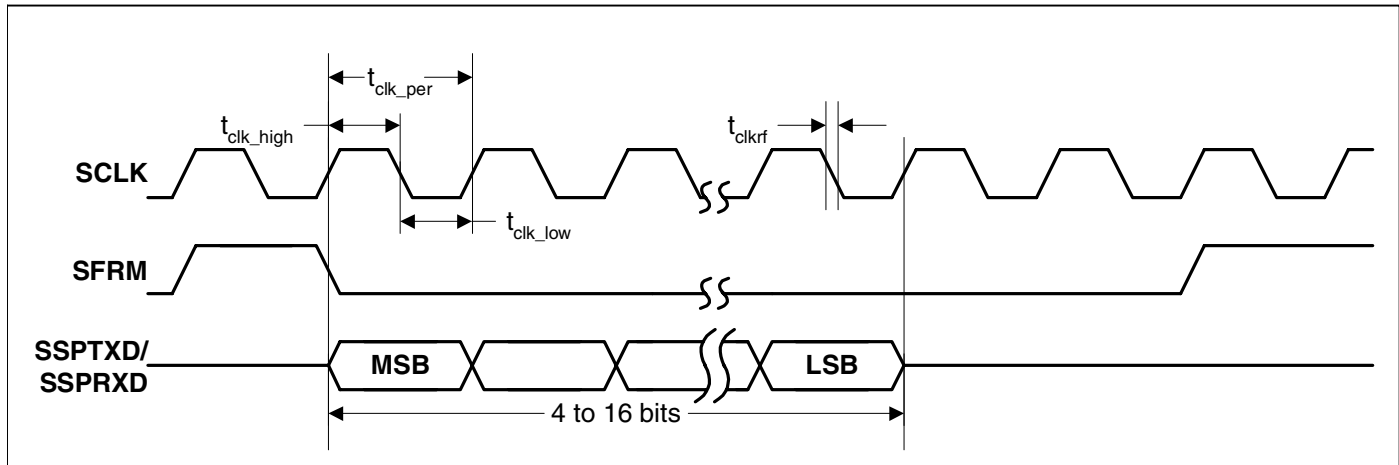

Figure 17. SPI Single Transfer Timing Measurement

**Microwire**

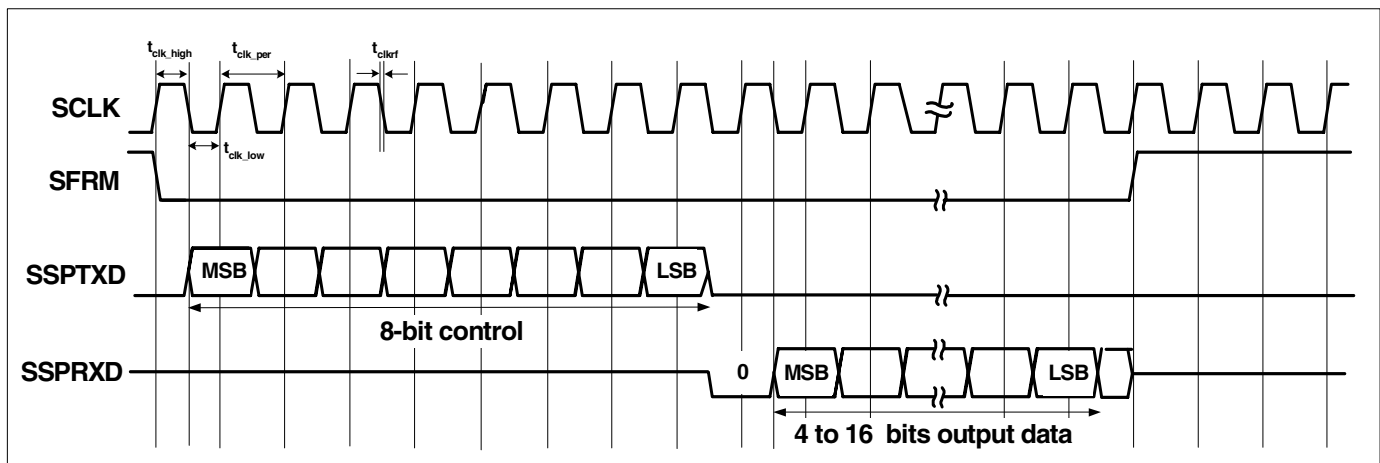

Figure 18. Microwire Frame Format, Single Transfer

Motorola SPI

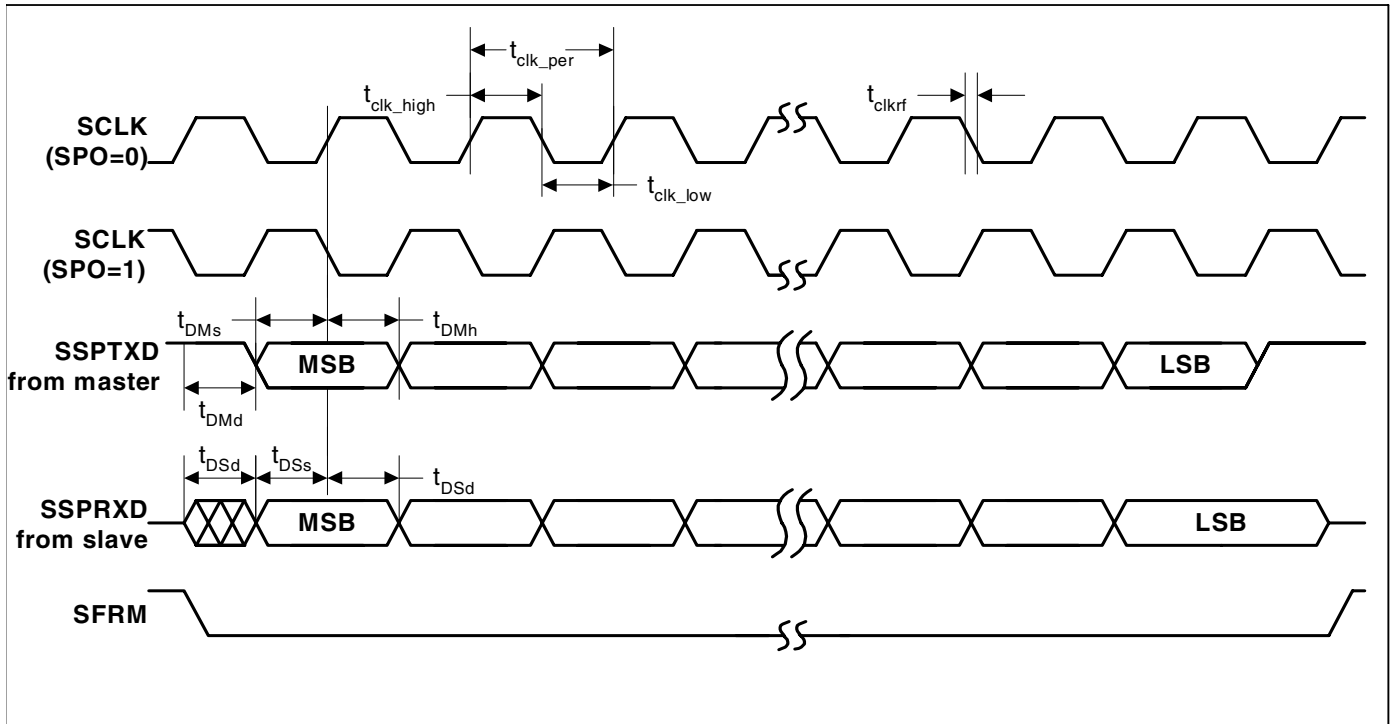

Figure 19. SPI Format with SPH=1 Timing Measurement

## Inter-IC Sound - I<sup>2</sup>S

| Parameter                        | Symbol          | Min | Typ                  | Max | Unit |
|----------------------------------|-----------------|-----|----------------------|-----|------|
| SCLK cycle time                  | $t_{clk\_per}$  | -   | $t_{i2s\_clk}$       | -   | ns   |
| SCLK high time                   | $t_{clk\_high}$ | -   | $(t_{i2s\_clk}) / 2$ | -   | ns   |
| SCLK low time                    | $t_{clk\_low}$  | -   | $(t_{i2s\_clk}) / 2$ | -   | ns   |
| SCLK rise/fall time              | $t_{clkrf}$     | -   | 4                    | -   | ns   |
| SCLK to LRCLK assert delay time  | $t_{LRs}$       | -   | 1.5                  | -   | ns   |
| LRCLK from SCLK assert hold time | $t_{LRh}$       | -   | 1.5                  | -   | ns   |
| SDI to SCLK deassert setup time  | $t_{SDIs}$      | -   | 20                   | -   | ns   |
| SDI from SCLK deassert hold time | $t_{SDIh}$      | -   | 10                   | -   | ns   |
| SCLK to SDO assert delay time    | $t_{SDOd}$      | -   | 4                    | -   | ns   |
| SDO from SCLK assert hold time   | $t_{SDOh}$      | -   | 4                    | -   | ns   |

Note:  $t_{i2s\_clk}$  is programmable by the user.

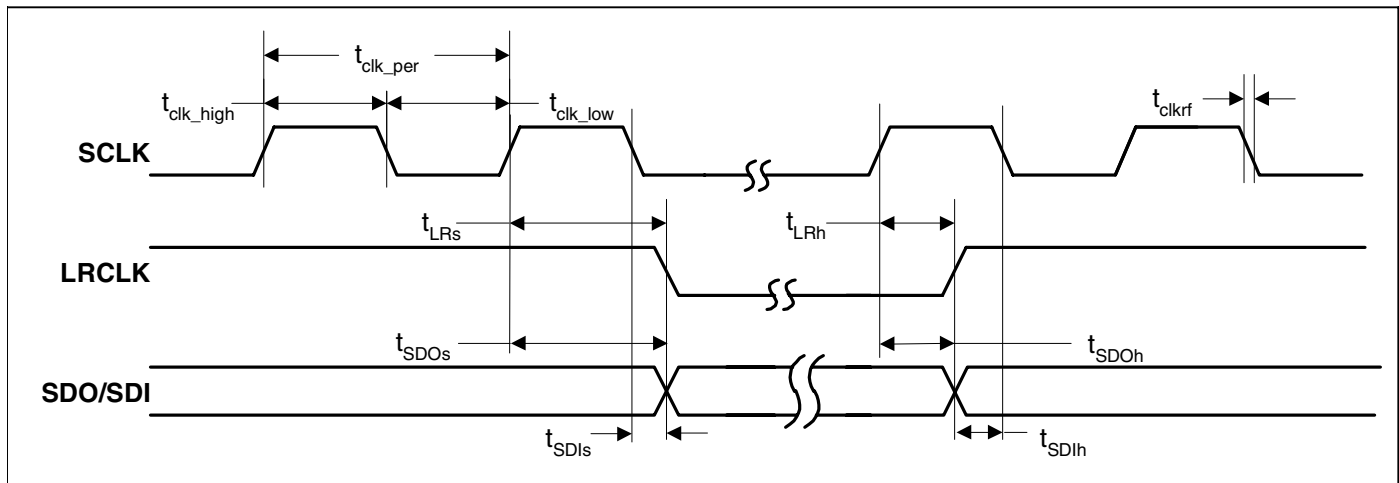
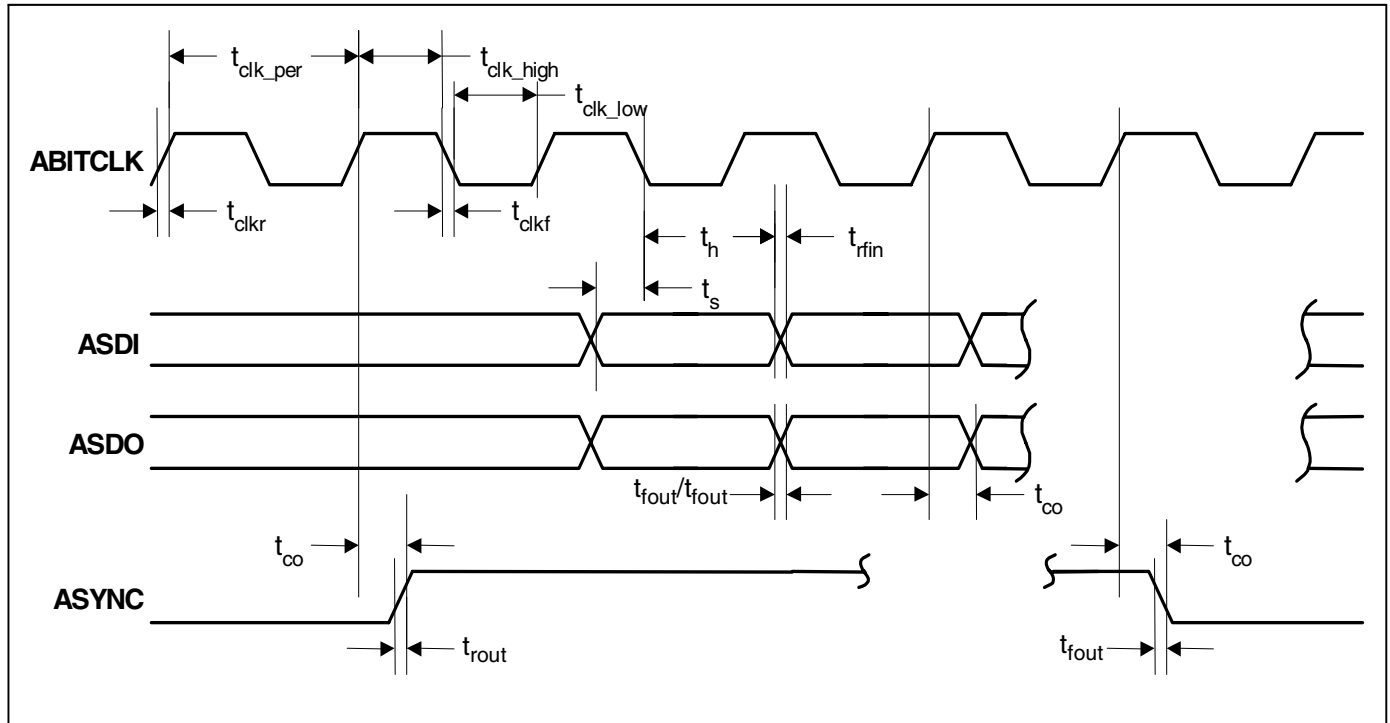

Figure 20. Inter-IC Sound (I<sup>2</sup>S) Timing Measurement

**AC'97**

| Parameter   | Symbol          | Min | Typ  | Max | Unit |
|---|-----------------|-----|------|-----|------|
| ABITCLK input cycle time                          | $t_{clk\_per}$  | -   | 81.4 | -   | ns   |
| ABITCLK input high time                           | $t_{clk\_high}$ | 36  | -    | 45  | ns   |
| ABITCLK input low time                            | $t_{clk\_low}$  | 36  | -    | 45  | ns   |
| ABITCLK input rise time                           | $t_{clkr}$      | 2   | -    | 6   | ns   |
| ABITCLK input fall time                           | $t_{clkf}$      | 2   | -    | 6   | ns   |
| ASDI setup to ABITCLK falling                     | $t_s$           | 10  | 23   | -   | ns   |
| ASDI hold after ABITCLK falling                   | $t_h$           | 10  | 53   | -   | ns   |
| ASDI input rise/fall time                         | $t_{rfin}$      | 2   | -    | 6   | ns   |
| ABITCLK rising to ASDO/ASYNC valid, $C_L = 55$ pF | $t_{co}$        | 2   | -    | 15  | ns   |
| ASYNC/ASDO rise time, $C_L = 55$ pF               | $t_{rout}$      | 2   | -    | 6   | ns   |
| ASYNC/ASDO fall time, $C_L = 55$ pF               | $t_{fout}$      | 2   | -    | 6   | ns   |

**Figure 21. AC '97 Configuration Timing Measurement**

## LCD Interface

| Parameter  | Symbol     | Min | Typ             | Max | Unit |
|--|------------|-----|-----------------|-----|------|
| SPCLK rising time                                    | $t_{clkr}$ | -   | 5               | -   | ns   |
| SPCLK falling time                                   | $t_{clkf}$ | -   | 5               | -   | ns   |
| SPCLK rising edge to control signal transition time  | $t_{CD}$   | -   | 1               | -   | ns   |
| SPCLK rising edge to data transition time            | $t_{DD}$   | -   | 0               | -   | ns   |
| SPCLK falling edge to control signal transition time | $t_{CDi}$  | -   | $(t_{SPCLK})/2$ | -   | ns   |
| SPCLK falling edge to data transition time           | $t_{DDi}$  | -   | $(t_{SPCLK})/2$ | -   | ns   |
| Data valid time                                      | $t_{Dv}$   | -   | $t_{SPCLK}$     | -   | ns   |

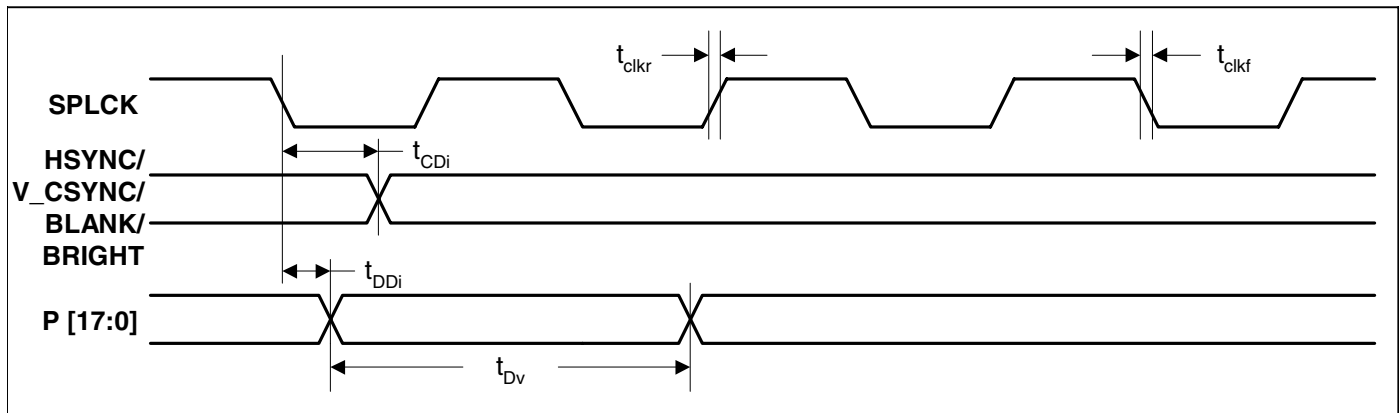
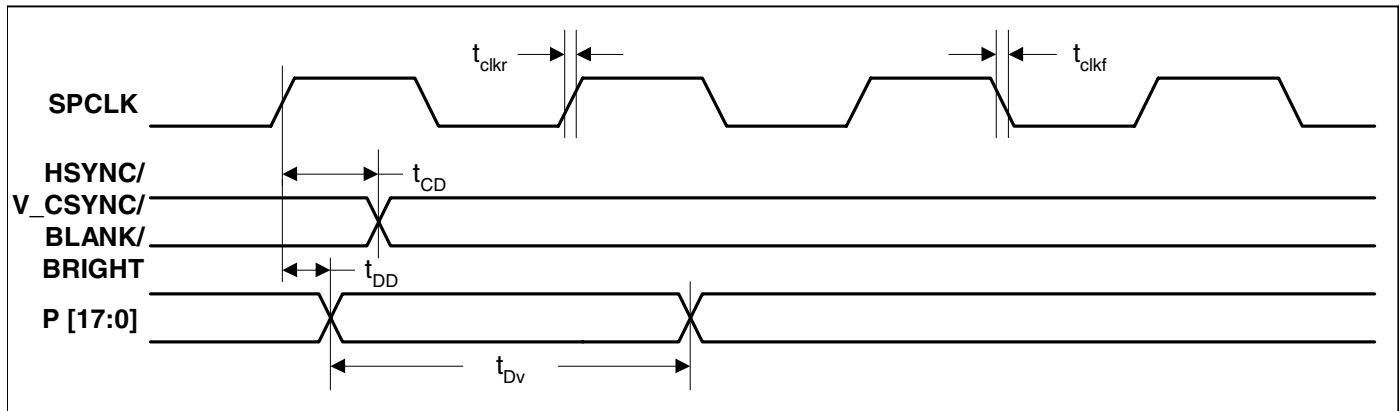
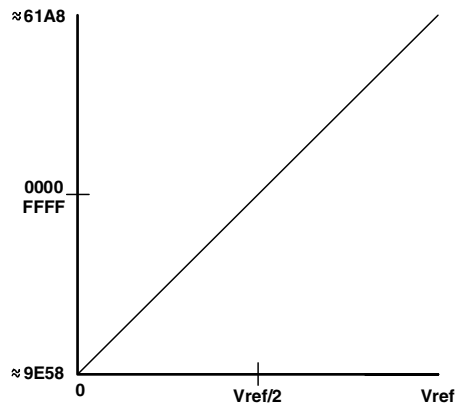

Figure 22. LCD Timing Measurement

## ADC

| Parameter                    | Comment                                 | Value                    | Units                                    |
|------------------------------|---|--------------------------|--|
| Resolution                   | No missing codes<br>Range of 0 to 3.3 V | 50K counts (approximate) |  |
| Integral non-linearity       |   | 0.01%                    |  |
| Offset error                 |   | ±15                      | mV                                       |
| Full scale error             |   | 0.2%                     |  |
| Maximum sample rate          | ADIV = 0<br>ADIV = 1                    | 3750<br>925              | Samples per second<br>Samples per second |
| Channel switch settling time | ADIV = 0<br>ADIV = 1                    | 500<br>2                 | µs<br>ms                                 |
| Noise (RMS) - typical        |   | 120                      | µV                                       |

Note: ADIV refers to bit 16 in the KeyTchClkDiv register.  
 ADIV = 0 means the input clock to the ADC module is equal to the external 14.7456 MHz clock divided by 4.  
 ADIV = 1 means the input clock to the ADC module is equal to the external 14.7456 MHz clock divided by 16.



**A/D Converter Transfer Function**  
 (approximately ±25,000 counts)

**Figure 23. ADC Transfer Function**

Using the ADC:

This ADC has a state-machine based conversion engine that automates the conversion process. The initiator for a conversion is the read access of the TSXYResult register by the CPU. The data returned from reading this register contains the result as well as the status bit indicating the state of the ADC. However, this peripheral requires a delay between each successful conversion and the issue of the next conversion command, or else the returned value of successive samples may not reflect the analog input. Since the state of the ADC state machine is returned through the same channel used to initiate the conversion process, there must be a delay inserted after every complete conversion. Note that reading TSXYResult during a conversion will not affect the result of the ongoing process.

The following is a recommended procedure for safely polling the ADC from software:

1. Read the TSXYResult register into a local variable to initiate a conversion.
2. If the value of bit 31 of the local variable is '0', repeat step 1.
3. Delay long enough to meet the maximum sample rate as shown above.
4. Mask the local variable with 0xFFFF to remove extraneous data.
5. If signed mode is used, do a sign extend of the lower halfword.
6. Return the sampled value.

## JTAG

| Parameter                                | Symbol          | Min | Max | Units |
|--|-----------------|-----|-----|-------|
| TCK clock period                         | $t_{clk\_per}$  | 100 | -   | ns    |
| TCK clock high time                      | $t_{clk\_high}$ | 50  | -   | ns    |
| TCK clock low time                       | $t_{clk\_low}$  | 50  | -   | ns    |
| TMS/TDI to clock rising setup time       | $t_{JP_s}$      | 20  | -   | ns    |
| Clock rising to TMS/TDI hold time        | $t_{JP_h}$      | 45  | -   | ns    |
| JTAG port clock to output                | $t_{JP_{co}}$   | -   | 30  | ns    |
| JTAG port high impedance to valid output | $t_{JP_{zx}}$   | -   | 30  | ns    |
| JTAG port valid output to high impedance | $t_{JP_{xz}}$   | -   | 30  | ns    |

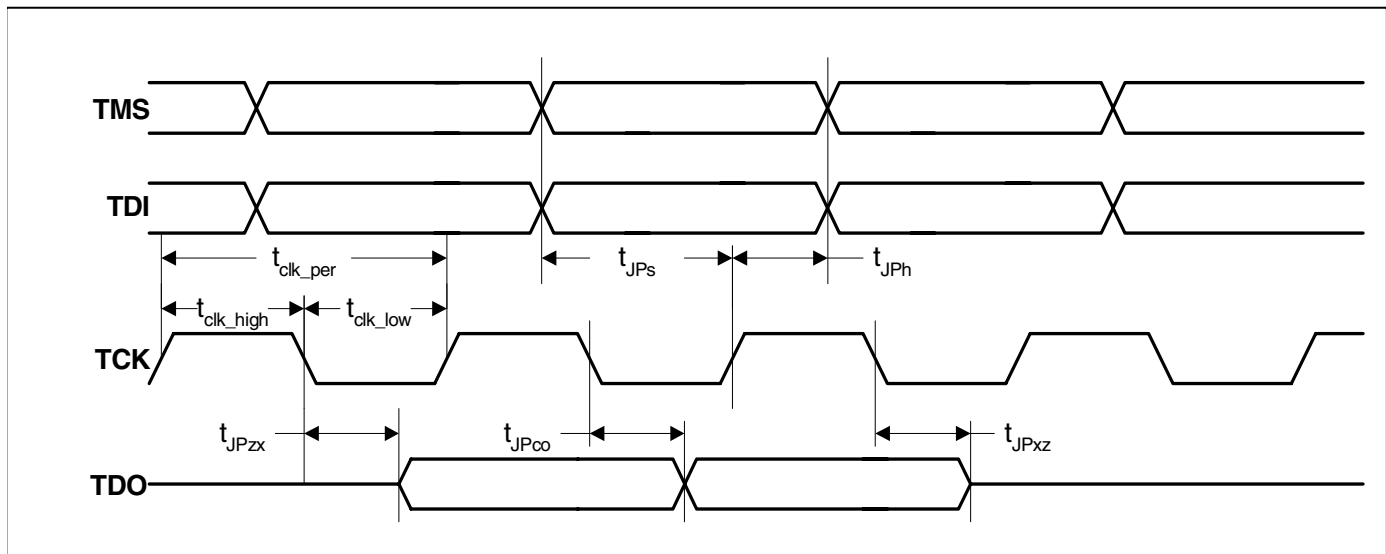

Figure 24. JTAG Timing Measurement

# 272 Pin TFBGA Package Outline

## 272 TFBGA Diagram

**Figure 25. 272 Pin TFBGA Diagram**

Table R. 272 Pin Diagram Dimensions

| Symbol | dimension in mm |       |       | dimension in inches |        |        |
|--------|-----------------|-------|-------|---------------------|--------|--------|
|        | MIN             | NOM   | MAX   | MIN                 | NOM    | MAX    |
| A      | 1.35            | 1.40  | 1.45  | 0.053               | 0.055  | 0.057  |
| A1     | 0.23            | 0.28  | 0.33  | 0.009               | 0.011  | 0.013  |
| A2     | 0.65            | 0.70  | 0.75  | 0.026               | 0.028  | 0.030  |
| b      | 0.35            | 0.40  | 0.45  | 0.014               | 0.016  | 0.018  |
| c      | 0.21            | 0.26  | 0.31  | 0.0083              | 0.0102 | 0.0122 |
| D      | 13.95           | 14.00 | 14.05 | 0.549               | 0.551  | 0.553  |
| D3     | 12.75           | 12.80 | 12.85 | 0.502               | 0.504  | 0.506  |
| E      | 13.95           | 14.00 | 14.05 | 0.549               | 0.551  | 0.553  |
| E3     | 12.75           | 12.80 | 12.85 | 0.502               | 0.504  | 0.506  |
| e      | 0.75            | 0.80  | 0.85  | 0.030               | 0.031  | 0.033  |
| ddd    |                 |       | 0.10  |                     |        | 0.004  |

- Note:
1. Controlling Dimension: Millimeter.
  2. Primary Datum C and seating plane are defined by the spherical crowns of the solder balls.
  3. Dimension b is measured at the maximum solder ball diameter, parallel to Primary Datum C.
  4. There shall be a minimum clearance of 0.25 mm between the edge of the solder ball and the body edge.
  5. Reference Document: JEDEC MO-151, BAL-2

## 272 Pin TFBGA Pinout (Bottom View)

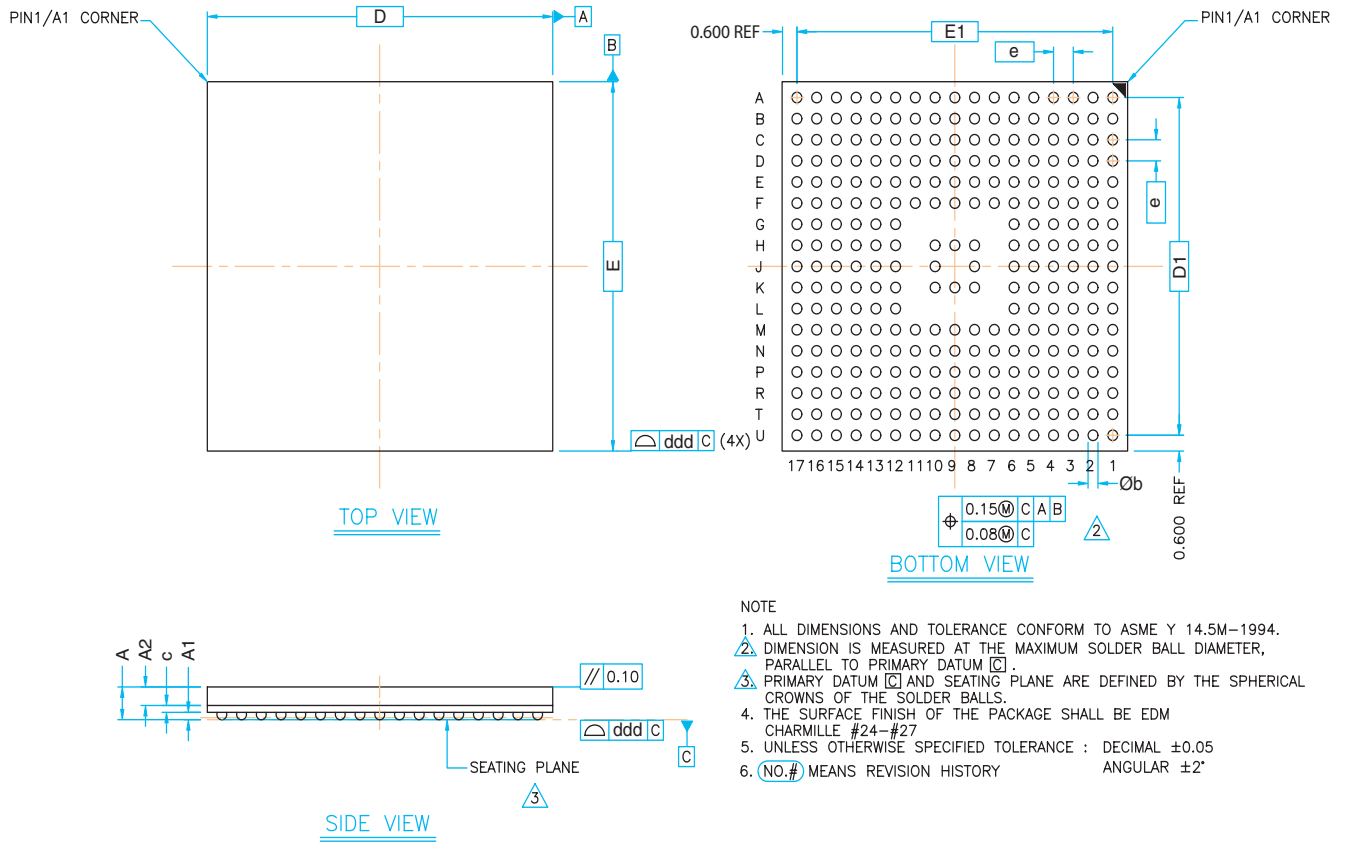
The following table shows the 272 pin TFBGA pinout. (For better understanding, compare the coordinates on the x and y axis on Figure 26, "272 Pin TFBGA Pinout", on page 41 with Figure 25, "272 Pin TFBGA Diagram", on page 39.

- VDD\_core is vddc.
- VDD\_ring is vddr.
- GND\_core is gndc.
- GND\_ring is gndr.



Figure 26. 272 Pin TFBGA Pinout

|          | 1        | 2        | 3        | 4        | 5        | 6        | 7        | 8        | 9         | 10        | 11        | 12        | 13        | 14        | 15        | 16        | 17        |          |
|----------|----------|----------|----------|----------|----------|----------|----------|----------|-----------|-----------|-----------|-----------|-----------|-----------|-----------|-----------|-----------|----------|
| <b>U</b> | NC       | NC       | P[8]     | P[4]     | P[1]     | DA[6]    | DA[3]    | AD[10]   | DA[0]     | TDO       | NC        | SCLK[1]   | SSPRX[1]  | INT[1]    | RTSn      | USBm[1]   | NC        | <b>U</b> |
| <b>T</b> | NC       | NC       | V_CSYNC  | P[7]     | P[2]     | DA[7]    | AD[11]   | AD[9]    | DSRn      | TMS       | gndr      | SFRM[1]   | INT[2]    | INT[0]    | USBp[1]   | NC        | NC        | <b>T</b> |
| <b>R</b> | P[9]     | HSYNC    | P[6]     | P[5]     | P[0]     | AD[14]   | DA[4]    | DA[1]    | DTRn      | TDI       | BOOT[0]   | ASYN      | SSPTX[1]  | PWMOUT    | USBm[0]   | ABITCLK   | USBp[0]   | <b>R</b> |
| <b>P</b> | SPCLK    | P[10]    | P[11]    | P[3]     | AD[15]   | AD[13]   | AD[12]   | DA[2]    | AD[8]     | TCK       | BOOT[1]   | EEDAT     | GRLED     | RDLED     | GGPIO[2]  | RXD[1]    | RXD[2]    | <b>P</b> |
| <b>N</b> | P[14]    | P[16]    | P[15]    | P[13]    | P[12]    | DA[5]    | vddr     | vddr     | vddr      | vddr      | EECLK     | ASDO      | CTSn      | RXD[0]    | TXD[0]    | TXD[1]    | TXD[2]    | <b>N</b> |
| <b>M</b> | BRIGHT   | AD[0]    | DQMn[1]  | DQMn[2]  | P[17]    | gndr     | gndr     | vddc     | vddc      | gndr      | gndr      | ROW[6]    | ROW[4]    | ROW[1]    | ROW[0]    | ROW[3]    | ROW[2]    | <b>M</b> |
| <b>L</b> | DA[9]    | AD[2]    | AD[1]    | DA[8]    | BLANK    | gndr     |          |          |           |           |           | gndr      | ROW[7]    | ROW[5]    | PLL_GND   | XTALI     | XTALO     | <b>L</b> |
| <b>K</b> | AD[4]    | DA[12]   | DA[10]   | DA[11]   | vddr     | gndr     |          | gndc     | gndc      | gndc      |           | vddc      | COL[4]    | PLL_VDD   | COL[2]    | COL[1]    | COL[0]    | <b>K</b> |
| <b>J</b> | AD[6]    | DA[14]   | AD[7]    | DA[13]   | vddr     | vddc     |          | gndc     |           | gndc      |           | vddc      | vddr      | COL[5]    | COL[6]    | CSn[0]    | COL[3]    | <b>J</b> |
| <b>H</b> | DA[18]   | DA[20]   | DA[19]   | DA[16]   | vddr     | vddc     |          | gndc     | gndc      | gndc      |           | gndr      | vddr      | EGPIO[8]  | PRSTn     | COL[7]    | RSTOn     | <b>H</b> |
| <b>G</b> | DQMn[0]  | CASn     | DA[21]   | AD[22]   | vddr     | gndr     |          |          |           |           |           | gndr      | EGPIO[9]  | EGPIO[10] | EGPIO[11] | RTCXTALO  | RTCXTALI  | <b>G</b> |
| <b>F</b> | RASn     | SDCSn[1] | SDCSn[0] | DQMn[3]  | AD[5]    | gndr     | gndr     | gndr     | vddc      | vddc      | gndr      | EGPIO[7]  | EGPIO[5]  | ADC_GND   | EGPIO[6]  | sYm       | sYp       | <b>F</b> |
| <b>E</b> | SDCSn[2] | SDWEN    | DA[22]   | AD[3]    | DA[15]   | AD[21]   | DA[17]   | vddr     | vddr      | vddr      | MIIRXD[0] | TXERR     | EGPIO[2]  | EGPIO[4]  | EGPIO[3]  | sXp       | sXm       | <b>E</b> |
| <b>D</b> | SDCSn[3] | DA[23]   | SDCLK    | DA[24]   | HGPIO[7] | HGPIO[6] | DA[28]   | HGPIO[4] | AD[16]    | MDC       | RXERR     | MIITXD[3] | EGPIO[12] | EGPIO[1]  | EGPIO[0]  | Ym        | Yp        | <b>D</b> |
| <b>C</b> | AD[23]   | DA[26]   | CSn[3]   | DA[25]   | AD[24]   | AD[19]   | HGPIO[5] | WRn      | MDIO      | MIIRXD[2] | TXCLK     | MIITXD[0] | CLD       | EGPIO[13] | TRSTn     | Xp        | Xm        | <b>C</b> |
| <b>B</b> | AD[25]   | CSn[2]   | CSn[6]   | AD[20]   | DA[30]   | AD[18]   | HGPIO[3] | AD[17]   | RXCLK     | MIIRXD[1] | MIITXD[2] | TXEN      | FGPIO[5]  | EGPIO[15] | USBp[2]   | ARSTn     | ADC_VDD   | <b>B</b> |
| <b>A</b> | CSn[1]   | CSn[7]   | SDCLKEN  | DA[31]   | DA[29]   | DA[27]   | HGPIO[2] | RDn      | MIIRXD[3] | RXDVAL    | MIITXD[1] | CRS       | FGPIO[7]  | FGPIO[0]  | WAITn     | USBm[2]   | ASDI      | <b>A</b> |
|          | <b>1</b> | <b>2</b> | <b>3</b> | <b>4</b> | <b>5</b> | <b>6</b> | <b>7</b> | <b>8</b> | <b>9</b>  | <b>10</b> | <b>11</b> | <b>12</b> | <b>13</b> | <b>14</b> | <b>15</b> | <b>16</b> | <b>17</b> |          |

## Pin List

The following Thin-profile Fine-pitch Ball Grid Array (TFBGA) ball assignment table is sorted in order of ball.

| Ball | Signal    | Ball | Signal    | Ball | Signal  | Ball | Signal   |
|------|-----------|------|-----------|------|---------|------|----------|
| A1   | CSn[1]    | E1   | SDCSn[2]  | J10  | gndc    | P1   | SPCLK    |
| A2   | CSn[7]    | E2   | SDWEN     | J12  | vddr    | P2   | P[10]    |
| A3   | SDCLKEN   | E3   | DA[22]    | J13  | COL[5]  | P3   | P[11]    |
| A4   | DA[31]    | E4   | AD[3]     | J14  | COL[6]  | P4   | P[3]     |
| A5   | DA[29]    | E5   | DA[15]    | J15  | CSn[0]  | P5   | AD[15]   |
| A6   | DA[27]    | E6   | AD[21]    | J16  | COL[3]  | P6   | AD[13]   |
| A7   | HGPIO[2]  | E7   | DA[17]    | J17  | vddc    | P7   | AD[12]   |
| A8   | RDn       | E8   | vddr      | K1   | AD[4]   | P8   | DA[2]    |
| A9   | MIIRXD[3] | E9   | vddr      | K2   | DA[12]  | P9   | AD[8]    |
| A10  | RXDVAL    | E10  | vddr      | K3   | DA[10]  | P10  | TCK      |
| A11  | MIITXD[1] | E11  | MIIRXD[0] | K4   | DA[11]  | P11  | BOOT[1]  |
| A12  | CRS       | E12  | TXERR     | K5   | vdr     | P12  | EEDAT    |
| A13  | FGPIO[7]  | E13  | EGPIO[2]  | K6   | gndr    | P13  | GRLED    |
| A14  | FGPIO[0]  | E14  | EGPIO[4]  | K8   | gndc    | P14  | RDLED    |
| A15  | WAITn     | E15  | EGPIO[3]  | K9   | gndc    | P15  | GGPIO[2] |
| A16  | USBm[2]   | E16  | sXp       | K10  | gndc    | P16  | RXD[1]   |
| A17  | ASDI      | E17  | sXm       | K12  | vddc    | P17  | RXD[2]   |
| B1   | AD[25]    | F1   | RASn      | K13  | COL[4]  | R1   | P[9]     |
| B2   | CSn[2]    | F2   | SDCSn[1]  | K14  | PLL_VDD | R2   | HSYNC    |
| B3   | CSn[6]    | F3   | SDCSn[0]  | K15  | COL[2]  | R3   | P[6]     |
| B4   | AD[20]    | F4   | DQMn[3]   | K16  | COL[1]  | R4   | P[5]     |
| B5   | DA[30]    | F5   | AD[5]     | K17  | COL[0]  | R5   | P[0]     |
| B6   | AD[18]    | F6   | gndr      | L1   | DA[9]   | R6   | AD[14]   |
| B7   | HGPIO[3]  | F7   | gndr      | L2   | AD[2]   | R7   | DA[4]    |
| B8   | AD[17]    | F8   | gndr      | L3   | AD[1]   | R8   | DA[1]    |
| B9   | RXCLK     | F9   | vddc      | L4   | DA[8]   | R9   | DTRn     |
| B10  | MIIRXD[1] | F10  | vddc      | L5   | BLANK   | R10  | TDI      |
| B11  | MIITXD[2] | F11  | gndr      | L6   | gndr    | R11  | BOOT[0]  |
| B12  | TXEN      | F12  | EGPIO[7]  | L12  | gndr    | R12  | ASYNC    |
| B13  | FGPIO[5]  | F13  | EGPIO[5]  | L13  | ROW[7]  | R13  | SSPTX[1] |
| B14  | EGPIO[15] | F14  | ADC_GND   | L14  | ROW[5]  | R14  | PWMOUT   |
| B15  | USBp[2]   | F15  | EGPIO[6]  | L15  | PLL_GND | R15  | USBm[0]  |
| B16  | ARSTn     | F16  | sYm       | L16  | XTALI   | R16  | ABITCLK  |
| B17  | ADC_VDD   | F17  | sYp       | L17  | XTALO   | R17  | USBp[0]  |
| C1   | AD[23]    | G1   | DQMn[0]   | M1   | BRIGHT  | T1   | NC       |
| C2   | DA[26]    | G2   | CASn      | M2   | AD[0]   | T2   | NC       |
| C3   | CSn[3]    | G3   | DA[21]    | M3   | DQMn[1] | T3   | V_CSYN   |
| C4   | DA[25]    | G4   | AD[22]    | M4   | DQMn[2] | T4   | P[7]     |
| C5   | AD[24]    | G5   | vddr      | M5   | P[17]   | T5   | P[2]     |
| C6   | AD[19]    | G6   | gndr      | M6   | gndr    | T6   | DA[7]    |
| C7   | HGPIO[5]  | G12  | gndr      | M7   | gndr    | T7   | AD[11]   |
| C8   | WRn       | G13  | EGPIO[9]  | M8   | vddc    | T8   | AD[9]    |

| Ball | Signal    | Ball | Signal    | Ball | Signal           | Ball | Signal           |
|------|-----------|------|-----------|------|------------------|------|------------------|
| C9   | MDIO      | G14  | EGPIO[10] | M9   | vddc             | T9   | DSRn             |
| C10  | MIIRXD[2] | G15  | EGPIO[11] | M10  | gndr             | T10  | TMS              |
| C11  | TXCLK     | G16  | RTCXTALO  | M11  | gndr             | T11  | gndr             |
| C12  | MIITXD[0] | G17  | RTCXTALI  | M12  | ROW[6]           | T12  | SFRM[1]          |
| C13  | CLD       | H1   | DA[18]    | M13  | ROW[4]           | T13  | INT[2]           |
| C14  | EGPIO[13] | H2   | DA[20]    | M14  | ROW[1]           | T14  | INT[0]           |
| C15  | TRSTn     | H3   | DA[19]    | M15  | ROW[0]           | T15  | USBp[1]          |
| C16  | Xp        | H4   | DA[16]    | M16  | ROW[3]           | T16  | NC               |
| C17  | Xm        | H5   | vddr      | M17  | ROW[2]           | T17  | NC               |
| D1   | SDCSn[3]  | H6   | vddc      | N1   | P[14]            | U1   | NC               |
| D2   | DA[23]    | H8   | gndc      | N2   | P[16]            | U2   | NC               |
| D3   | SDCLK     | H9   | gndc      | N3   | P[15]            | U3   | P[8]             |
| D4   | DA[24]    | H10  | gndc      | N4   | P[13]            | U4   | P[4]             |
| D5   | HGPIO[7]  | H12  | gndr      | N5   | P[12]            | U5   | P[1]             |
| D6   | HGPIO[6]  | H13  | vddr      | N6   | DA[5]            | U6   | DA[6]            |
| D7   | DA[28]    | H14  | EGPIO[8]  | N7   | vddr             | U7   | DA[3]            |
| D8   | HGPIO[4]  | H15  | PRSTn     | N8   | vddr             | U8   | AD[10]           |
| D9   | AD[16]    | H16  | COL[7]    | N9   | vddr             | U9   | DA[0]            |
| D10  | MDC       | H17  | RSTOn     | N10  | vddr             | U10  | TDO              |
| D11  | RXERR     | J1   | AD[6]     | N11  | EECLK            | U11  | NC               |
| D12  | MIITXD[3] | J2   | DA[14]    | N12  | ASDO             | U12  | SCLK[1]          |
| D13  | EGPIO[12] | J3   | AD[7]     | N13  | CTS <sub>n</sub> | U13  | SSPRX[1]         |
| D14  | EGPIO[1]  | J4   | DA[13]    | N14  | RXD[0]           | U14  | INT[1]           |
| D15  | EGPIO[0]  | J5   | vddr      | N15  | TXD[0]           | U15  | RTS <sub>n</sub> |
| D16  | Ym        | J6   | vddc      | N16  | TXD[1]           | U16  | USBm[1]          |
| D17  | Yp        | J8   | gndc      | N17  | TXD[2]           | U17  | NC               |

The following section focuses on the EP9307 pin signals from two viewpoints - the pin usage and pad characteristics, and the pin multiplexing usage. The first table (Table S) is a summary of all the EP9307 pin signals. The second table (Table T) illustrates the pin signal multiplexing and configuration options.

Table S is a summary of the EP9307 pin signals, which illustrates the pad type and pad pull type (if any). The symbols used in the table are defined as follows. (Note: A blank box means Not Applicable (NA) or, for Pull Type, No Pull (NP).)

Under the Pad Type column:

- A - Analog pad

- P - Power pad
- G - Ground pad
- I - Pin is an input only
- I/O - Pin is input/output
- 4mA - Pin is a 4mA output driver
- 8mA - Pin is an 8mA output driver
- 12mA - Pin is an 12mA output driver

See the text description for additional information about bi-directional pins.

Under the Pull Type Column:

- PU - Resistor is a pull up to the RVDD supply
- PD - Resistor is a pull down to the RGND supply

Table S. Pin Descriptions

| Pin Name   | Block  | Pad Type | Pull Type | Description                                |
|------------|--------|----------|-----------|--|
| TCK        | JTAG   | I        | PD        | JTAG clock in                              |
| TDI        | JTAG   | I        | PD        | JTAG data in                               |
| TDO        | JTAG   | 4ma      | -         | JTAG data out                              |
| TMS        | JTAG   | I        | PD        | JTAG test mode select                      |
| TRSTn      | JTAG   | I        | PD        | JTAG reset                                 |
| BOOT[1:0]  | System | I        | PD        | Boot mode select in                        |
| XTALI      | PLL    | A        | -         | Main oscillator input                      |
| XTALO      | PLL    | A        | -         | Main oscillator output                     |
| VDD_PLL    | PLL    | P        | -         | Main oscillator power, 1.8V                |
| GND_PLL    | PLL    | G        | -         | Main oscillator ground                     |
| RTCXTALI   | RTC    | A        | -         | RTC oscillator input                       |
| RTCXTALO   | RTC    | A        | -         | RTC oscillator output                      |
| WRn        | EBUS   | 4ma      | -         | SRAM Write strobe out                      |
| RDn        | EBUS   | 4ma      | -         | SRAM Read/OE strobe out                    |
| WAITn      | EBUS   | I        | PU        | SRAM Wait in                               |
| AD[25:0]   | EBUS   | 8ma      | -         | Shared Address bus out                     |
| DA[31:0]   | EBUS   | 8ma      | PU        | Shared Data bus in/out                     |
| CSn[3:0]   | EBUS   | 4ma      | PU        | Chip select out                            |
| CSn[7:6]   | EBUS   | 4ma      | PU        | Chip select out                            |
| DQMn[3:0]  | EBUS   | 8ma      | -         | Shared data mask out                       |
| SDCLK      | SDRAM  | 8ma      | -         | SDRAM clock out                            |
| SDCLKEN    | SDRAM  | 8ma      | -         | SDRAM clock enable out                     |
| SDCSn[3:0] | SDRAM  | 4ma      | -         | SDRAM chip selects out                     |
| RASn       | SDRAM  | 8ma      | -         | SDRAM RAS out                              |
| CASn       | SDRAM  | 8ma      | -         | SDRAM CAS out                              |
| SDWEn      | SDRAM  | 8ma      | -         | SDRAM write enable out                     |
| P[17:0]    | Raster | 4ma      | PU        | Pixel data bus out                         |
| SPCLK      | Raster | 12ma     | PU        | Pixel clock in/out                         |
| HSYNC      | Raster | 8ma      | PU        | Horizontal synchronization/ line pulse out |

Table S. Pin Descriptions (Continued)

| Pin Name    | Block  | Pad Type | Pull Type | Description   |
|-------------|--------|----------|-----------|---|
| V_CS SYNC   | Raster | 8ma      | PU        | Vertical or composite synchronization/frame pulse out |
| BLANK       | Raster | 8ma      | PU        | Composite blanking signal out                         |
| BRIGHT      | Raster | 4ma      | -         | PWM brightness control out                            |
| PWMOUT      | PWM    | 8ma      |           | Pulse width modulator output                          |
| Xp, Xm      | ADC    | A        | -         | Touchscreen ADC X axis                                |
| Yp, Ym      | ADC    | A        | -         | Touchscreen ADC Y axis                                |
| sXp, sXm    | ADC    | A        | -         | Touchscreen ADC X axis feedback                       |
| sYp, sYm    | ADC    | A        | -         | Touchscreen ADC Y axis feedback                       |
| VDD_ADC     | ADC    | P        | -         | Touchscreen ADC power, 3.3V                           |
| GND_ADC     | ADC    | G        | -         | Touchscreen ADC ground                                |
| COL[7:0]    | Key    | 8ma      | PU        | Key matrix column inputs                              |
| ROW[7:0]    | Key    | 8ma      | PU        | Key matrix row outputs                                |
| USBp[2:0]   | USB    | A        | -         | USB positive signals                                  |
| USBm[2:0]   | USB    | A        | -         | USB negative signals                                  |
| TXD0        | UART1  | 4ma      | -         | Transmit out  |
| RXD0        | UART1  | I        | PU        | Receive in  |
| CTS n       | UART1  | I        | PU        | Clear to send/transmit enable                         |
| DSR n       | UART1  | I        | PU        | Data set ready/Data Carrier Detect                    |
| DTR n       | UART1  | 4ma      | -         | Data Terminal Ready output                            |
| RTS n       | UART1  | 4ma      | -         | Ready to send   |
| TXD1        | UART2  | 4ma      | -         | Transmit/IrDA output                                  |
| RXD1        | UART2  | I        | PU        | Receive/IrDA input                                    |
| TXD2        | UART3  | 4ma      | -         | Transmit  |
| RXD2        | UART3  | I        | PU        | Receive   |
| MDC         | EMAC   | 4ma      |           | Management data clock                                 |
| MDIO        | EMAC   | 4ma      | PU        | Management data input/output                          |
| RXCLK       | EMAC   | I        | PD        | Receive clock in                                      |
| MIIRXD[3:0] | EMAC   | I        | PD        | Receive data in                                       |
| RXDVAL      | EMAC   | I        | PD        | Receive data valid                                    |

**Table S. Pin Descriptions (Continued)**

| Pin Name       | Block  | Pad Type | Pull Type | Description                       |
|----------------|--------|----------|-----------|-----------------------------------|
| RXERR          | EMAC   | I        | PD        | Receive data error                |
| TXCLK          | EMAC   | 4ma      | PU        | Transmit clock in                 |
| MIITXD[3:0]    | EMAC   | I        | PD        | Transmit data out                 |
| TXEN           | EMAC   | 4ma      | PD        | Transmit enable                   |
| TXERR          | EMAC   | 4ma      | PD        | Transmit error                    |
| CRS            | EMAC   | I        | PD        | Carrier sense                     |
| CLD            | EMAC   | I        | PU        | Collision detect                  |
| GRLED          | LED    | 12ma     | -         | Green LED                         |
| RDLED          | LED    | 12ma     | -         | Red LED                           |
| EECLK          | EEPROM | 4ma      | PU        | EEPROM/Two-wire Interface clock   |
| EEDAT          | EEPROM | 4ma      | PU        | EEPROM/Two-wire Interface data    |
| ABITCLK        | AC97   | 8ma      | PD        | AC97 bit clock                    |
| ASYN           | AC97   | 8ma      | PD        | AC97 frame sync                   |
| ASDI           | AC97   | I        | PD        | AC97 Primary input                |
| ASDO           | AC97   | 8ma      | PU        | AC97 output                       |
| ARSTn          | AC97   | 8ma      | -         | AC97 reset                        |
| SCLK1          | SPI1   | 8ma      | PD        | SPI bit clock                     |
| SFRM1          | SPI1   | 8ma      | PD        | SPI Frame Clock                   |
| SSPRX1         | SPI1   | I        | PD        | SPI input                         |
| SSPTX1         | SPI1   | 8ma      | -         | SPI output                        |
| INT[2:0]       | INT    | I        | PD        | External interrupts               |
| PRSTn          | Syscon | I        | PU        | Power on reset                    |
| RSTOn          | Syscon | 4ma      | -         | User Reset in out - open drain    |
| SLA[0]         | EEPROM | 4ma      | -         | Flash programming voltage control |
| EGPIO[15]      | GPIO   | I/O, 4ma | PU        | Enhanced GPIO                     |
| EGPIO[13:0]    | GPIO   | I/O, 4ma | PU        | Enhanced GPIO                     |
| FGPIO[7, 5, 0] | GPIO   | I/O, 8ma | PU        | GPIO                              |
| GGPIO[2]       | GPIO   | I/O, 8ma | PU        | GPIO                              |
| HGPIO[7:2]     | GPIO   | I/O, 8ma | PU        | GPIO                              |
| vddc           | Power  | P        | -         | Digital power, 1.8V               |
| vddr           | Power  | P        | -         | Digital power, 3.3V               |
| gndc           | Ground | G        | -         | Digital ground                    |
| gndr           | Ground | G        | -         | Digital ground                    |

Table T illustrates the pin signal multiplexing and configuration options.

**Table T. Pin Multiplex Usage Information**

| Physical Pin Name | Description             | Multiplex signal name |
|-------------------|-------------------------|-----------------------|
| COL[7:0]          | GPIO                    | GPIO Port D[7:0]      |
| ROW[7:0]          | GPIO                    | GPIO Port C[7:0]      |
| EGPIO[0]          | Ring Indicator Input    | RI                    |
| EGPIO[1]          | 1Hz clock monitor       | CLK1HZ                |
| EGPIO[2]          | DMA request             | DMARQ                 |
| EGPIO[3]          | HDLC Clock              | HDLCCLK1              |
| EGPIO[4]          | I2S Transmit Data 1     | SDO1                  |
| EGPIO[5]          | I2S Receive Data 1      | SDI1                  |
| EGPIO[6]          | I2S Transmit Data 2     | SDO2                  |
| EGPIO[7]          | DMA Request 0           | DREQ0                 |
| EGPIO[8]          | DMA Acknowledge 0       | DACK0                 |
| EGPIO[9]          | DMA EOT 0               | DEOT0                 |
| EGPIO[10]         | DMA Request 1           | DREQ1                 |
| EGPIO[11]         | DMA Acknowledge 1       | DACK1                 |
| EGPIO[12]         | DMA EOT 1               | DEOT1                 |
| EGPIO[13]         | I2S Receive Data 2      | SDI2                  |
| EGPIO[15]         | Device active / present | DASP                  |
| ABITCLK           | I2S Serial clock        | SCLK                  |
| ASYNC             | I2S Frame Clock         | LRCK                  |
| ASDO              | I2S Transmit Data 0     | SDO0                  |
| ASDI              | I2S Receive Data 0      | SDI0                  |
| ARSTn             | I2S Master clock        | MCLK                  |
| SCLK1             | I2S Serial clock        | SCLK                  |
| SFRM1             | I2S Frame Clock         | LRCK                  |
| SSPTX1            | I2S Transmit Data 0     | SDO0                  |
| SSPRX1            | I2S Receive Data 0      | SDI0                  |

## Acronyms and Abbreviations

The following tables list abbreviations and acronyms used in this data sheet.

| Term             | Definition  |
|------------------|---|
| ADC              | Analog-to-Digital Converter                         |
| ALT              | Alternative   |
| AMBA             | Advanced Micro-controller Bus Architecture          |
| ATAPI            | ATA Packet Interface                                |
| CODEC            | COder/DECoder                                       |
| CRC              | Cyclic Redundancy Check                             |
| DAC              | Digital-to-Analog Converter                         |
| DMA              | Direct-Memory Access                                |
| EEPROM           | Electrically Erasable Programmable Read Only Memory |
| EMAC             | Ethernet Media Access Controller                    |
| EBUS             | External Bus  |
| FIFO             | First In/First Out                                  |
| FIQ              | Fast Interrupt Request                              |
| FLASH            | Flash memory  |
| GPIO             | General Purpose I/O                                 |
| HDLC             | High-level Data Link Control                        |
| I/F              | Interface   |
| I <sup>2</sup> S | Inter-IC Sound                                      |
| IC               | Integrated Circuit                                  |
| ICE              | In-Circuit Emulator                                 |
| IDE              | Integrated Drive Electronics                        |
| IEEE             | Institute of Electronics and Electrical Engineers   |
| IrDA             | Infrared Data Association                           |
| IRQ              | Standard Interrupt Request                          |
| ISO              | International Standards Organization                |
| JTAG             | Joint Test Action Group                             |
| LFSR             | Linear Feedback Shift Register                      |
| MII              | Media Independent Interface                         |
| MMU              | Memory Management Unit                              |

| Term  | Definition   |
|-------|--|
| OHCI  | Open Host Controller Interface   |
| PHY   | Ethernet PHYSical layer interface  |
| PIO   | Programmed I/O   |
| RISC  | Reduced Instruction Set Computer   |
| SDMI  | Secure Digital Music Initiative  |
| SDRAM | Synchronous Dynamic RAM  |
| SPI   | Serial Peripheral Interface  |
| SRAM  | Static Random Access Memory  |
| STA   | Station - Any device that contains an IEEE 802.11 conforming Medium Access Control (MAC) and physical layer (PHY) interface to the wireless medium |
| TFT   | Thin Film Transistor   |
| TLB   | Translation Lookaside Buffer   |
| USB   | Universal Serial Bus   |

## Units of Measurement

| Symbol | Unit of Measure   |
|--------|---|
| °C     | degree Celsius  |
| Hz     | Hertz = cycle per second                                    |
| Kbps   | Kilobits per second   |
| Kbyte  | Kilobyte  |
| KHz    | KiloHertz = 1000 Hz   |
| Mbps   | Megabits per second   |
| MHz    | MegaHertz = 1,000 KiloHertz                                 |
| μA     | microAmpere = 10 <sup>-6</sup> Ampere                       |
| μs     | microsecond = 1,000 nanoseconds = 10 <sup>-6</sup> seconds  |
| mA     | milliAmpere = 10 <sup>-3</sup> Ampere                       |
| ms     | millisecond = 1,000 microseconds = 10 <sup>-3</sup> seconds |
| mW     | milliWatt = 10 <sup>-3</sup> Watts                          |
| ns     | nanosecond = 10 <sup>-9</sup> seconds                       |
| pF     | picoFarad = 10 <sup>-12</sup> Farads                        |
| V      | Volt  |
| W      | Watt  |

## ORDERING INFORMATION

The order numbers for the device are:

|            |                |               |           |
|------------|----------------|---------------|-----------|
| EP9307-CB  | 0°C to +70°C   | 272 pin TFBGA |           |
| EP9307-CBZ | 0°C to +70°C   | 272 pin TFBGA | Lead Free |
| EP9307-IB  | -40°C to +85°C | 272 pin TFBGA |           |
| EP9307-IBZ | -40°C to +85°C | 272 pin TFBGA | Lead Free |

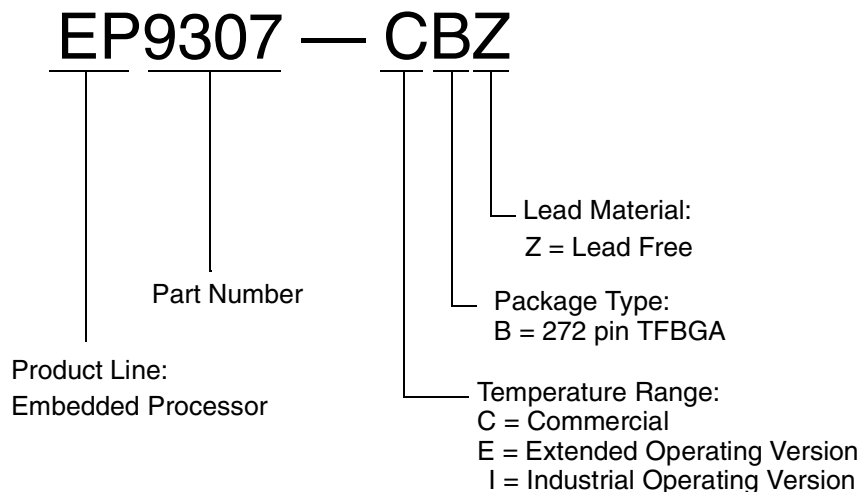

Note: Go to the Cirrus Logic Internet site at <http://www.cirrus.com> to find contact information for your local sales representative.

## Contacting Cirrus Logic Support

For all product questions and inquiries contact a Cirrus Logic Sales Representative.  
To find one nearest you go to [www.cirrus.com](http://www.cirrus.com)

### IMPORTANT NOTICE

"Preliminary" product information describes products that are in production, but for which full characterization data is not yet available. Cirrus Logic, Inc. and its subsidiaries ("Cirrus") believe that the information contained in this document is accurate and reliable. However, the information is subject to change without notice and is provided "AS IS" without warranty of any kind (express or implied). Customers are advised to obtain the latest version of relevant information to verify, before placing orders, that information being relied on is current and complete. All products are sold subject to the terms and conditions of sale supplied at the time of order acknowledgment, including those pertaining to warranty, patent infringement, and limitation of liability. No responsibility is assumed by Cirrus for the use of this information, including use of this information as the basis for manufacture or sale of any items, or for infringement of patents or other rights of third parties. This document is the property of Cirrus and by furnishing this information, Cirrus grants no license, express or implied under any patents, mask work rights, copyrights, trademarks, trade secrets or other intellectual property rights. Cirrus owns the copyrights associated with the information contained herein and gives consent for copies to be made of the information only for use within your organization with respect to Cirrus integrated circuits or other products of Cirrus. This consent does not extend to other copying such as copying for general distribution, advertising or promotional purposes, or for creating any work for resale.

CERTAIN APPLICATIONS USING SEMICONDUCTOR PRODUCTS MAY INVOLVE POTENTIAL RISKS OF DEATH, PERSONAL INJURY, OR SEVERE PROPERTY OR ENVIRONMENTAL DAMAGE ("CRITICAL APPLICATIONS"). CIRRUS PRODUCTS ARE NOT DESIGNED, AUTHORIZED OR WARRANTED FOR USE IN AIRCRAFT SYSTEMS, MILITARY APPLICATIONS, PRODUCTS SURGICALLY IMPLANTED INTO THE BODY, LIFE SUPPORT PRODUCTS OR OTHER CRITICAL APPLICATIONS (INCLUDING MEDICAL DEVICES, AIRCRAFT SYSTEMS OR COMPONENTS AND PERSONAL OR AUTOMOTIVE SAFETY OR SECURITY DEVICES). INCLUSION OF CIRRUS PRODUCTS IN SUCH APPLICATIONS IS UNDERSTOOD TO BE FULLY AT THE CUSTOMER'S RISK AND CIRRUS DISCLAIMS AND MAKES NO WARRANTY, EXPRESS, STATUTORY OR IMPLIED, INCLUDING THE IMPLIED WARRANTIES OF MERCHANTABILITY AND FITNESS FOR PARTICULAR PURPOSE, WITH REGARD TO ANY CIRRUS PRODUCT THAT IS USED IN SUCH A MANNER. IF THE CUSTOMER OR CUSTOMER'S CUSTOMER USES OR PERMITS THE USE OF CIRRUS PRODUCTS IN CRITICAL APPLICATIONS, CUSTOMER AGREES, BY SUCH USE, TO FULLY INDEMNIFY CIRRUS, ITS OFFICERS, DIRECTORS, EMPLOYEES, DISTRIBUTORS AND OTHER AGENTS FROM ANY AND ALL LIABILITY, INCLUDING ATTORNEYS' FEES AND COSTS, THAT MAY RESULT FROM OR ARISE IN CONNECTION WITH THESE USES.

Cirrus Logic, Cirrus, MaverickCrunch, MaverickKey, and the Cirrus Logic logo designs are trademarks of Cirrus Logic, Inc. All other brand and product names in this document may be trademarks or service marks of their respective owners.

Microsoft and Windows are registered trademarks of Microsoft Corporation.

Microwire is a trademark of National Semiconductor Corp. National Semiconductor is a registered trademark of National Semiconductor Corp.

Texas Instruments is a registered trademark of Texas Instruments, Inc.

Motorola is a registered trademark of Motorola, Inc.

LINUX is a registered trademark of Linus Torvalds.