







-  Compliant with IEEE802.3 standard including 350uH OCL with 8mA DC bias
-  Designed to withstand IR-Reflow with peak temperature per IPC/JEDEC J-STD-020C
-  Operating temperature 0°C to +70°C
-  Symmetrical TX and RX channels suitable for Auto MDI/MDIX applications
-  RoHS compliant version is available



**ELECTRICAL SPECIFICATION @ 25°C**

Part Number	RoHS Part Number	Insertion Loss (dB Max)	Return Loss (dB Min)					CMRR (dB Min)				Crosstalk (dB Min)	Hipot (Vrms)
			1-100MHz	2-30MHz	40MHz	50MHz	60-80MHz	2-30MHz	60MHz	100MHz	200MHz		
824-00273	824-00273F	1.0	16.0	13.5	11.5	10.0	40.0	33.0	28.0	21.5	31.0	1500	

**MECHANICAL DIMENSIONS**

Package: SO024C

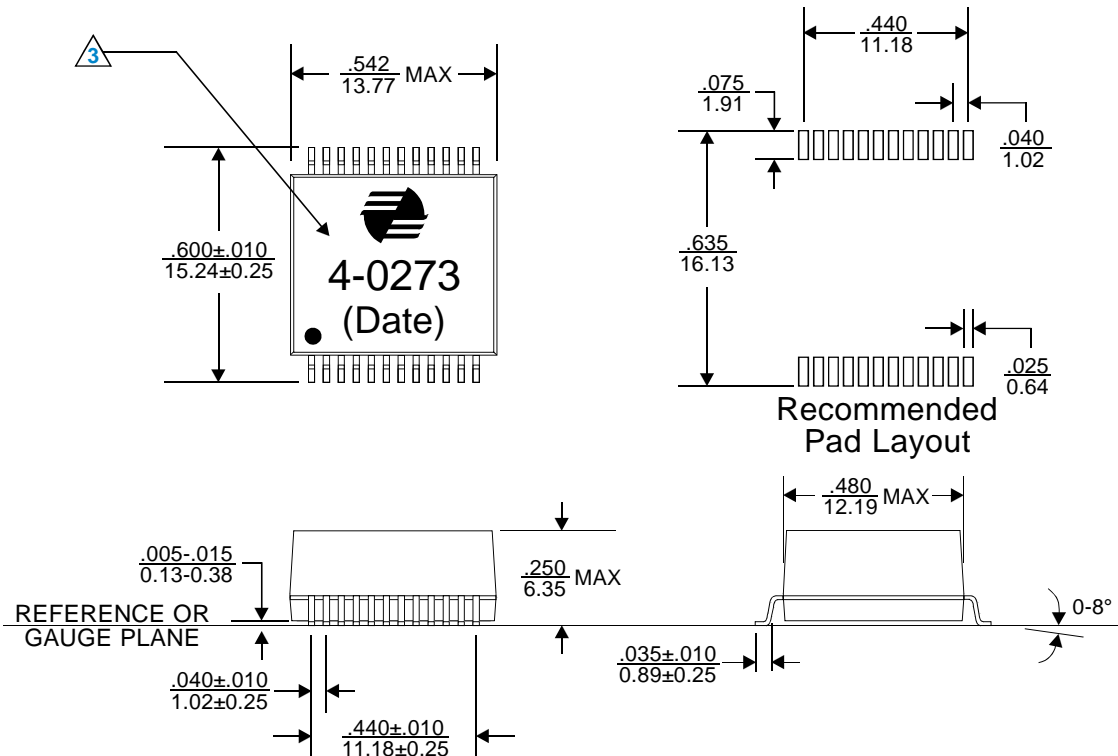

**Notes:**

1. All dimensions are specified in  $\frac{\text{inches}}{\text{mm}}$  with higher precedence in inches.
2. Unless otherwise specified, all tolerances are  $\pm \frac{.010}{0.25}$ .
3. For available RoHS part number, the part will be marked with "4-0273F", instead of "4-0273".

Weight (in gram)	: 2.4 typ.
Tape & Reel	: 450 / reel



SCHMATICS

824-00273

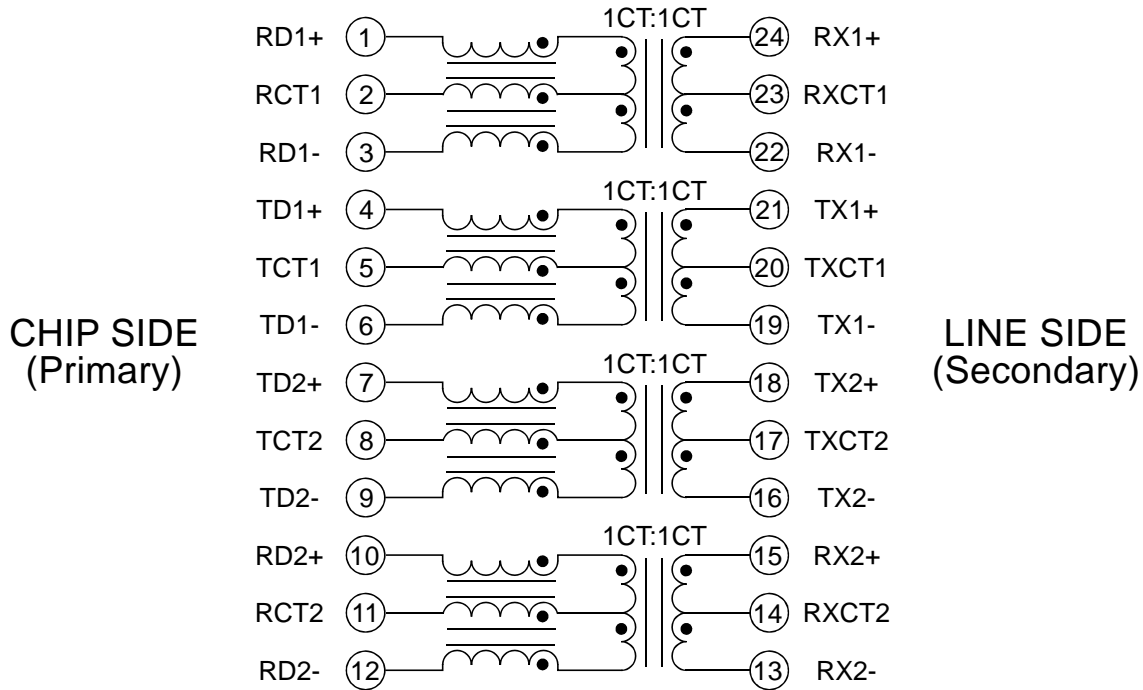

FOR MORE INFORMATION, PLEASE CONTACT

HEADQUARTER  
2/F Block A, Merit Industrial Centre,  
94 Tokwawan Road, Kowloon,  
Hong Kong  
Tel: (852) 2765 3888  
Fax: (852) 2954 3304  
Email: eempl@eleceltek.com  
Website: <http://www.eleceltek.com>

Information herein is for reference only and subject to change without notice. It does not constitute any representation, warranty or commitment of the company in respect of the products in any aspect. All logos, brands and product names mentioned herein are trademarks or registered trademarks of their respective owners. The company does not assume any liability arising out of the application or use of any product or circuit described herein. Copyrights 2006, E & E Magnetic Products Limited.