

FE100/200(-M)

eXtended FAXENGINE™ Device Set

The Conexant™ FE100/200(-M) eXtended FAXENGINE adds error diffusion, Dark Level Correction (DLC), and Flash Memory Support to the suite of facsimile functions already supported by the XFE family. It is packaged in a two-device set consisting of a Conexant eXtended Facsimile Controller (FC100/200(-M)) and a Conexant MONOFAX® Modem. This family of eXtended FAXENGINE devices provides upgrade capabilities via its hardware and software compatible controllers; the FE100/200 is backward-compatible with other XFE device sets. Starting with the basic FE100 fax controller which includes a DRAM controller and flash memory controller, voice support (-V) can be added, along with T.6 MMR with Alternating Compression/Decompression (ACD) (-M), and full-duplex digital speakerphone support (-S). The eXtended FAXENGINE Device Set combinations are shown in Table 1. The eXtended FAXENGINE Device set, including supplied firmware, comprises a complete facsimile machine controller—needing only a power supply, scanner, printer and paper path components to complete the machine.

The FAXENGINE Development System, including the FAXENGINE Evaluation System (FEES-X2) and the MC24 ROM Emulator (McFERE), provides a complete development environment.

eXtended FAXENGINE Controller (FC100, FC100-M, FC200, FC200-M)

The eXtended FAXENGINE Controller performs all common facsimile machine control, monitor and interface functions. The MC24™ embedded micro processor provides an 8-bit data bus, a 24-bit address bus and a direct external memory accessing capability to 16 MB.

Additionally, it contains scanner, printer, keyboard, stepper motor and modem interfaces. These programmable functions and interfaces support a wide range of peripherals. Integrated 8-bit pipeline ADC, clamp, sample hold, and AGC allow minimum external scanner interface hardware. Built-in DLC and shading correction combined with two-dimensional Error Diffusion and two-dimensional edge enhancement provides state-of-the-art image processing performance in half-tone modes.

The eXtended FAXENGINE Controller enables product design flexibility by virtue of its built-in peripheral and programmable hardware registers.

MONOFAX Modems

Seven MONOFAX modem models are available with selection depending upon the desired applications. The R144EFL and R96DFXL/R96DFXL-CID support V.17 14400 bps and V.29 9600 bps fax transmission and reception. The RFX96V24 and RFX144V24 add integrated fax and digital answering machine functionality by providing a low bit rate voice codec that provides 24 minutes of voice storage per 4 megabits of memory.

The RFX144V24-S and RFX96V24-S modems support the full range of features listed above and add full-duplex speakerphone features for hands-free applications. An External Integrated Analog (XIA) front-end is added for microphone and speaker interfaces to support full-duplex digital speakerphone operation (-S).

Distinguishing Features

- Microprocessor and Bus Interface
 - Enhanced MC24 central processing unit (CPU)
 - up to 10 MHz CPU clock speed
 - Memory efficient input/output bit manipulation
 - 8-bit data/24 bit address bus
- External Bus
 - Address, data, control, status, interrupt, and decoded chip select signals support connection to external ROM, external RAM, and optional peripheral devices
- Chip selects
 - ROMCSn for ROM support
 - CS0n for SRAM
 - CS1n for external peripherals
 - MCSn for modem
 - Optional general purpose: CS2n, CS3n, CS4n and CS5n
- DRAM Controller
 - Supports external page memory
 - Battery backup refresh with separate battery power
 - DMA Controller
 - Six dedicated internal DMA channels for scanner, printer, and T.4/T.6 access of internal and/or external memory
 - Internal Video RAM
 - 2K X 8 internal Video RAM is supported for 2-dimensional Error Diffusion image processing
 - External RAM: 11 MB
 - External ROM: 3 MB
 - Interrupt controller
 - Flash memory controller supports 2 MB NOR-type flash memories, Samsung NAND-type flash memory, and Toshiba NAND-type flash memory with internal synchronous serial port.
- T.4/T.6 Compression and Decompression in Hardware
 - MH/MR for FC100/200
 - MH/MR/MMR for FC100/200-M

- Motor Control for Scanner and Printer
 - Four outputs to external current drivers for the scanner motor and four for the printer motor
 - Motor outputs can be programmed as General Purpose Outputs (GPO) for application with a single motor or plain paper machines
- Scanner and Video Control
 - CCD and CIS scanners supported
 - Six programmable control signals:
 - Four programmable scanner control signals
 - Two video output control signals support external signal pre-processing
 - B4/A4 scanner support
 - 5 ms minimum line time
 - Line lengths to 2048 pixels
 - Scanner pipeline A/D Interface
 - Internal 8-bit pipeline A/D converter, clamp, sample and hold and automatic gain circuits are provided internally, A/D reference inputs available for control by external circuits
 - Video Processing
 - Per single pixel and per eight pixel shading correction
 - Dark Level Correction for 27 segments
 - 2-dimensional Error Diffusion Image processing (FE200 and FE200-M only)
 - 2 dimensional Edge enhancement
 - Up to 8x8 programmable dither table
 - Image data processing port allows access to scan data prior to video processing
 - Multi-level B4 to A4 size reduction
- Programmable Resolution Conversion (-M only)
 - Programmable 2-dimensional bi-level resolution conversion provides expansion to 200% and reduction to 33%
 - Vertical line ORing
 - Scanner output bit order reversal
- Thermal Printer Interface
 - 1 to 4 programmable strobe signals
 - Traditional printers and latchless "split mode" printers
 - Line lengths to 4096 pixels
 - A/D converter monitors printer head temperature
- Programmable Tone Generator
- Operator Interface
 - The interface can directly drive a 32-key keypad
 - A 8x15 keyboard array is supportable with external circuitry
 - Eight LEDs are driven directly
 - Typical LCD display modules are supported
- Autobaud Interface
 - Automatically detects baud rate of asynchronous serial data for external UART or built in SASIF support
- Synchronous Serial Interface (SSIF)
 - 2 Synchronous Interface
 - Master/Slave configuration (Clock)
 - Programmable clock rate
- Synchronous/Asynchronous Serial Interface (SASIF)
 - 1 Synchronous/Asynchronous interface
 - Programmable baud rate up to 14400 bps
- General Purpose Inputs and/or Outputs
 - Provides up to 20 GPIO and 8 GPO's
- Real Time Clock
 - Battery backup
 - 32-year range with leap year compensation
- Watchdog Timer
- Compact Packages
 - FC100/200: 144-pin TQFP
 - MONOFAX Modem: 100-pin PQFP
 - XIA: 28-pin PLCC
- FAXENGINE Development System (FEES-X2 and MC24 FERE)
 - Provides demonstration, prototype development, and evaluation capabilities to facsimile machine developers using the eXtended FAXENGINE Device Set
 - Connects to a host PC for software development

Information provided by Conexant Systems, Inc. is believed to be accurate and reliable. However, no responsibility is assumed by Conexant for its use, nor any infringement of patents or other rights of third parties which may result from its use. No license is granted by implication or otherwise under any patent rights of Conexant other than for circuitry embodied in Conexant products. Conexant reserves the right to change circuitry at any time without notice. This document is subject to change without notice.

Conexant and "What's Next in Communications Technologies" are trademarks of Conexant Systems, Inc.

Product names or services listed in this publication are for identification purposes only, and may be trademarks or registered trademarks of their respective companies. All other marks mentioned herein are the property of their respective holders.

©1999, Conexant Systems, Inc.

All Rights Reserved

Table 1. FE100/200(-M) Family Characteristics

eXtended FAXENGINE Device Set	Fax Controller	MONOFAX Fax Modem	MH/MR/MR/ ACD	Full-Duplex Speakerphone Support	Digital Answering Machine	Caller ID	Error Diffusion	External DMA Channel
R96FE100	FC100	R96DFXL	1	No	No	No	No	No
R96FE100-C	FC100	R96DFXL-CID	1	No	No	Yes	No	No
R96FE100-V24	FC100	RFX96V24	1	No	Yes	Yes	No	No
R96FE100-V24S	FC100	RFX96V24-S	1	Yes	Yes	Yes	No	No
R96FE100-M	FC100-M	R96DFXL	2	No	No	No	No	Yes
R96FE100-MC	FC100-M	R96DFXL-CID	2	No	No	Yes	No	Yes
R96FE100-MV24	FC100-M	RFX96V24	2	No	Yes	Yes	No	Yes
R96FE100-MV24S	FC100-M	RFX96V24-S	2	Yes	Yes	Yes	No	Yes
R144FE100	FC100	R144EFXL	1	No	No	No	No	No
R144FE100-C	FC100	R144EFXL-CID	1	No	No	Yes	No	No
R144FE100-V24	FC100	RFX144V24	1	No	Yes	Yes	No	No
R144FE100-V24S	FC100	RFX144V24-S	1	Yes	Yes	Yes	No	No
R144FE100-M	FC100-M	R144EFXL	2	No	No	No	No	Yes
R144FE100-MC	FC100-M	R144EFXL-CID	2	No	No	Yes	No	Yes
R144FE100-MV24	FC100-M	RFX144V24	2	No	Yes	Yes	No	Yes
R144FE100-MV24S	FC100-M	RFX144V24-S	2	Yes	Yes	Yes	No	Yes
R96FE200	FC200	R96DFXL	1	No	No	No	Yes	No
R96FE200-C	FC200	R96DFXL-CID	1	No	No	Yes	Yes	No
R96FE200-V24	FC200	RFX96V24	1	No	Yes	Yes	Yes	No
R96FE200-V24S	FC200	RFX96V24-S	1	Yes	Yes	Yes	Yes	No
R96FE200-M	FC200-M	R96DFXL	2	No	No	No	Yes	Yes
R96FE200-MC	FC200-M	R96DFXL-CID	2	No	No	Yes	Yes	Yes
R96FE200-MV24	FC200-M	RFX96V24	2	No	Yes	Yes	Yes	Yes
R96FE200-MV24S	FC200-M	RFX96V24-S	2	Yes	Yes	Yes	Yes	Yes
R144FE200	FC200	R144EFXL	1	No	No	No	Yes	No
R144FE200-C	FC200	R144EFXL-CID	1	No	No	Yes	Yes	No
R144FE200-V24	FC200	RFX144V24	1	No	Yes	Yes	Yes	No
R144FE200-V24S	FC200	RFX144V24-S	1	Yes	Yes	Yes	Yes	No
R144FE200-M	FC200-M	R144EFXL	2	No	No	No	Yes	Yes
R144FE200-MC	FC200-M	R144EFXL-CID	2	No	No	Yes	Yes	Yes
R144FE200-MV24	FC200-M	RFX144V24	2	No	Yes	Yes	Yes	Yes
R144FE200-MV24S	FC200-M	RFX144V24-S	2	Yes	Yes	Yes	Yes	Yes

Notes: 1. MH/MR compression and decompression.
2. MH/MR/MMR and Alternating Compression Decompression for Page memory.

FAXENGINE Firmware

The FAXENGINE firmware includes a complete software package—core code and application code—for the development of a customized facsimile machine. The following features are supported by the firmware:

- A real-time multitasking environment
- Modular software design
- T.30 protocol
- Call progress support for multiple countries
- T.4 MH/MR compression and decompression control
- T.6 MMR, Alternating compression/decompression and Page Memory handling management (-M only)
- B4 to A4 reduction
- Fax transmit, receive and copy capabilities
- Polling Tx/Rx
- Broadcast and Delayed Transmission functions (-M only)
- Digital Answering Machine functions (-V or -VS only)
- Full duplex Digital Speakerphone function (-VS only)
- Error diffusion (FC200 and FC200-M only)
- 64-level Dither Table support
- NAND or NOR type Flash memory control and support
- Programmable resolution conversion
- Voice/Fax Discrimination
- Caller ID

Core Code. The Core Code provides the functions with close functional proximity to the FE100/200(-M) hardware. The Core Code is provided in object code form ready for linking to developer-provided application program object code. The Core Code is highly structured for maximum application flexibility with minimum overhead.

Application Code. The Application Code “builds” an example fax machine using the FE100/200(-M) device set in the FEES-X2 environment. The Application Code is provided in source code form and serves as basis for the developer’s application.

FE100/200 eXtended FAXENGINE Development System

The Conexant FAXENGINE Evaluation System (FEES-X2) and MC24 FERE (Fax Engine ROM Emulator) provides demonstration, prototype development, and evaluation capabilities to facsimile machine developers using the FE100/200 eXtended FAXENGINE Device Set. The FEES-X2 offers flexibility for visibility and access. It consists with the Modem Evaluation Board, Data Access Arrangement (DAA), sockets for programmable parts, and connectors for an emulator and all fax machine peripherals. The ROM Emulator (MC24 FERE) is a PC-based firmware development/debugging environment with breakpoint and trace capability for developers.

Hardware Description

The FE100/200 system-level functional interface is shown in Figure 1.

Note: The suffix n indicates an active low signal.

eXtended Facsimile Controller (FC100/200)

The FC100/200 contains an internal 8-bit microprocessor with a 16MB external address space and dedicated circuitry optimized for facsimile image processing, image data compression/decompression and for facsimile machine control and monitoring.

Microprocessor

The microprocessor is an enhanced MC24 central processing unit (CPU). This CPU provides fast instruction execution and memory efficient input/output bit manipulation. The CPU connects to other internal FC100/200 functions over internal address, data and dedicated control buses. These buses are routed outside the FC100/200 for external memory access.

External Bus Control

Address, data, control, status, interrupt, and decoded chip select signals support connection to external ROM, external RAM, and optional DRAM and peripheral devices. Dedicated internal DMA logic is included for scanner, printer and T.4 access of internal and/or external RAM.

Six internal DMA channels support scanner, printer and T.4 access of the external shading and line buffer RAM. A programmable DMA channel is available to support T.4/T.6 access to external page memory.

External RAM and ROM

FC100/200 can use 3 MB of ROM and up to 1 MB of SRAM. ROM stores all the FAXENGINE program object code and SRAM is used by the FAXENGINE CPU, shading RAM, and line buffer RAM.

Independently programmable SRAM and ROM wait states from 0 to 3 are supported. SRAM sizes may be 8, 32, 64K and 1 MB.

Chip Selects

Various chip selects (CS) are provided by the FC100/200 such as ROMCS_n, CS0_n for SRAM, CS1_n for external peripherals, MCS_n for modem, and optional general purpose chip selects CS[4:2]_n and CS5_n.

Interrupt Signals

Up to three external interrupts are provided. IRQ8 (GPIO16) is an active high level sensitive interrupt and IRQ9_n (GPIO18) is an active low-level sensitive interrupt. MIRQ_n is dedicated to the modem.

Scanner and Printer Motor Control

Eight outputs are provided to external current drivers: four to the scanner motor and four to the printer motor. The printer and scanner motor outputs can be programmed as GPOs for applications using a single motor or plain paper printers.

T.4/T.6 Compressor/Decompressor

The FC100/200 implements MH/MR image data compression and decompression per ITU-T Recommendation T.4 in hardware. The FC100/200-M also provides MMR compression and decompression per ITU-T Recommendation T.6 in dedicated hardware. Compression and decompression can be alternated on a line-by-line basis in the FC100/200-M with the support of FE100/200-M Firmware.

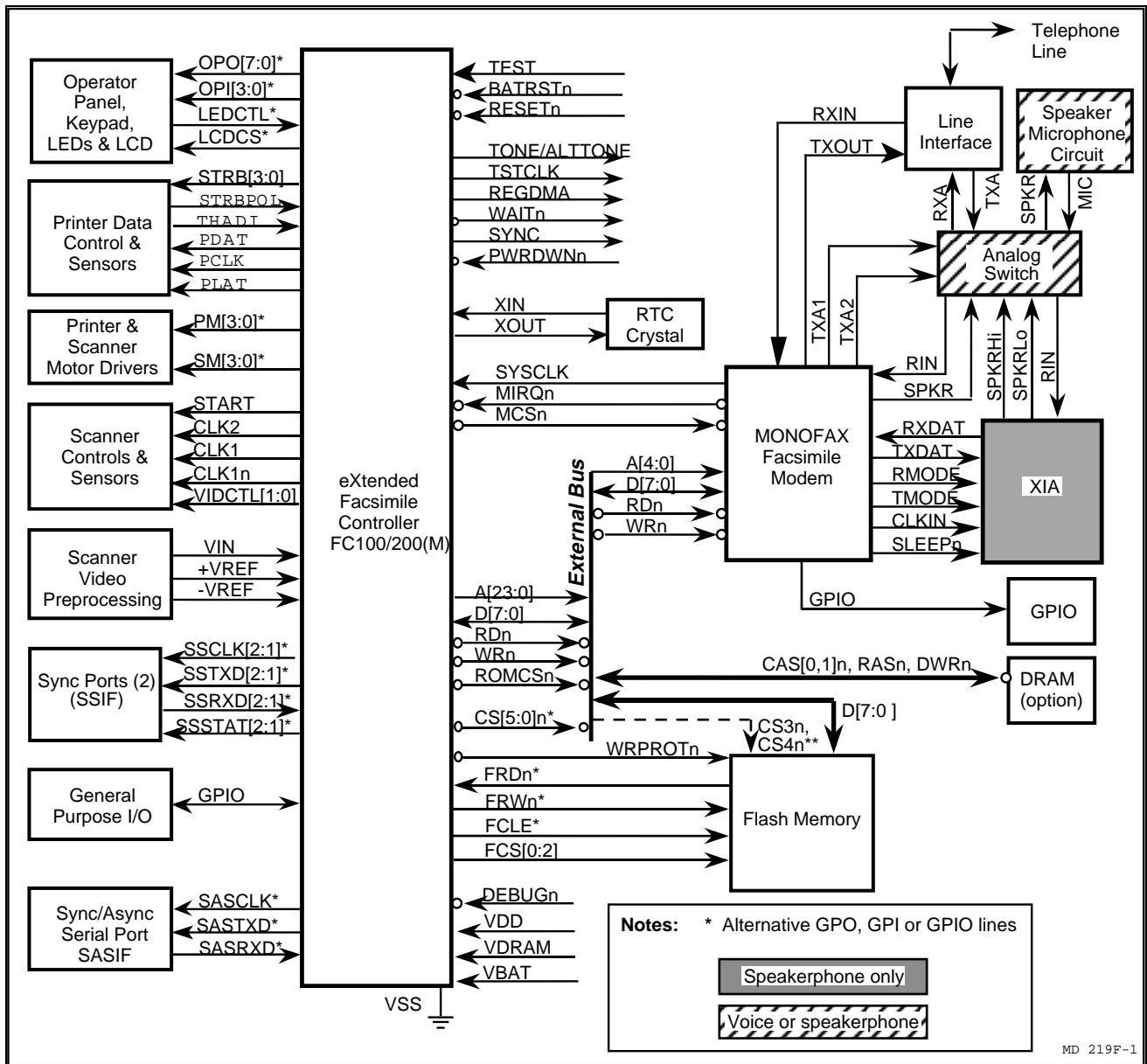

Figure 1. FE100/200 Functional Interconnect Diagram

DRAM Controller

The DRAM controller supports memory devices of the sizes, number of bits and access speeds tabulated below. DRAM memory space is divided into three blocks thus, if 4 MB chips are used, a maximum of 8 MB of DRAM is supported. Each block has a programmable size and starting address.

Addressing Size	4 MB, 1MB, 512K, 256K
No. of Bits	8, 4, 1
Access Speed (ns)	60 to 150

DRAM controller provides battery backup refresh using DRAM battery power (VDRAM).

Bi-Level Resolution Conversion (-M only)

Bi-level expansion (to 200%) and reduction (down to 33%) can be performed on either the scanner bi-level data or the bi-level data output by the T4/T6 decompression hardware.

Flash Memory Controller

The FC100/200(-M) includes a flash memory controller that supports the following types of flash memory and their equivalents:

Vendor	Model	Size (K)	Type
AMD	Am29F040	512	NOR
Intel	28F400BL	512	NOR
Toshiba	TC58A040F	512	Serial NAND
Samsung	KM29N040/080-150	Unlimited	NAND

Thermal Printer Control

The thermal printer interface consists of programmable data, latch, clock, and up to four strobe signals. Programmable timing supports traditional thermal printers, as well as latchless and two-clock split mode printers, and line lengths to 4096 pixels.

From one to four strobes are generated, with the length of the strobe cycle (line time) and strobe pulse width programmable. Line times from 5 to 40 ms are supported. A strap input to the FC100/200 sets strobe polarity.

Three signals (PDAT, PCLK, and PLAT) control the transfer of data to the printer.

The FC100/200 includes a 6-bit A/D converter (conversion rate < 80 ms full scale) to monitor the head temperature of the thermal printer. Two external terminating resistors are determined by the specific printhead selected.

Scanner and Video Control

Six programmable control and timing signals support common CCD and CIS scanners. The video control function provides signals for controlling the scanner and for processing its video output. Four programmable control signals (START, CLK1, CLK1n, and CLK2) provide timing related to line and pixel timing. These are programmable with regard to start time, relative delay and pulse width.

Two video control output signals (VIDCTL[1:0]) provide digital control for external signal pre-processing circuitry. These signals provide a per pixel period, or per line period, timing with programmable positive-going and negative-going transitions for each signal.

Scanner Pipeline A/D Interface

An internal 8-bit pipeline A/D converter (PADC) and ADC clock are provided. The A/D reference inputs (Vref+ and Vref-) are available for control by external circuits. A programmable ADC sample position is provided. Built-in Automatic Gain Control (AGC) amplifier and Input Analog (IA) clamping circuits are provided. External video circuits can be tailored by the developer.

Video Processing

The FC100/200 supports DLC and two modes of shading correction for scanner data non-uniformity's arising from uneven sensor output or uneven illumination. Correction may be provided to an 8-pixel group at a time or, separately to each pixel. Less than 1 K of RAM is required to support shading correction. A Digital Adaptive Halftone image processing is supported. A 2-Dimensional error diffusion algorithm as well as a 2-D Edge Enhancement control are performed in the hardware. Dynamic background and contrast control is provided for text images. Multi-level horizontal B4 to A4 reduction is also provided for the scanner data.

The FC100/200 includes an optional external image data processing port (multiplexed with GPIO) to allow the developer to access scan data prior to video processing.

Operator Interface

Operator interface functions are supported by the operator output bus OPO[7:0] the operator input bus OPI[3:0], and two control outputs (LEDCTL and LCDCS).

The FC100/200 can directly drive a 32-key keypad. External blocking diodes are required to isolate the keyboard strobe lines from the LEDs, as the LEDs and keyboard strobe signals use the same lines. Up to 8x15 keyboard array can be supportable with external circuitry.

Eight LEDs can be driven directly by the FC100/200. The keyboard strobes are shared with the LED drivers. An LED control signal is provided to disable the LEDs during keyboard strobing. The FC100/200 offsets LED turn on/off times thereby preventing power supply overload when all indicators are activated simultaneously. The LEDCTL signal can supply 12 ma.

Typical LCD display modules are driven by the FC100/200. The FC100/200 drives the 4-bit bus (OPO[3:0]) and two separate control lines (OPO4 and LCDCS) for LCD support. (For example, the FAXENGINE Development System FEES-X2 uses a 2-line, 20 character per line display.)

Synchronous Serial Interface (SSIF)

FE100/200 provides two Synchronous Serial Interfaces. The SSIF is configured to operate either as a Master or Slave interface (bi-directional Clock). The interface consists of three lines: SSTXD, SSRXD and SSCLK. Optional control signals for request (SSREQ) and acknowledge (SSACK) are supported in slave mode. Transmit and receive data shift direction and clock polarity is programmable. Internal interrupt can be generated when the receive data register is full.

Synchronous Asynchronous Serial Interface (SASIF)

The SASIF is configurable either as Synchronous or Asynchronous Serial Interface. This interface consists of three lines: SASTXD, SASRXD and clock (SASCLK). The SASIF includes a programmable baud rate generator and produces an 8X driving clock for internal logic. Receive data is double-buffered to ease received timing restrictions.

SASIF status can be read anytime by the CPU. Status includes: IRQ source (TXD or RXD) and operation mode (synchronous or asynchronous). The CPU can also control and monitor TXD and SCLK. RXD can be monitored at any time.

Autobaud

The autobaud circuit with supporting firmware is used to analyze a serial data stream in order to determine the baud rate and data structure (parity and character length) to program an external UART.

A precision timer, shift register and edge detector are included to determine the width of the start bit and to sample the serial data stream. Serial data rates up to 115.2 kbps are supported.

The serial transmitted data is connected to the precision timer and shift register inputs via the SERINP pin. The SEROUT pin is a gated version of the SERINP pin that can be enabled/disabled.

Real-Time Clock (RTC)

The FC100/200 includes a battery backup real-time clock. The RTC life is 32 years; its functions include leap year compensation. A 32.768 kHz watch crystal is required by the RTC.

General Purpose Inputs/Outputs

The FC100/200 provides 20 GPIO and 8 GPO lines.

Programmable Tone Generator

Two programmable tone generators each provide single tone digital output, variable in frequency from 20 to 4000 Hz.

System Timing

The FC100/200 derives its timing from the modem clock or from an external oscillator (max. frequency = 20 MHz). Two internal timer interrupts are provided:

- A 1 ms timer derived from the RTC oscillator timebase (exact period = 1.00708 ms).
- A programmable mechanical subsystem interrupt (MSINT) which serves as a source for motor stepping interrupts and/or scanner and printer interrupts. Independent, programmable, scan and print line times are supported.

Reset and Power Control

The BATRSTn input initializes the FC100/200 at power-on. An externally generated power-down input, PWRDWNn, controls switching between primary and battery power. The open drain RESETn I/O pin provides a reset output to external circuits, or can accept an externally generated reset. The external reset will not reset the RTC. Separate DRAM and RTC battery power inputs are provided for battery-backup functions.

Documentation

Documentation for the FE100/200 family of devices and MONOFAX modems are listed in Table 2.

Environmental and Power Requirements

Environmental specifications are shown in Table 3. Power requirements are shown in Table 4.

FC100/200 Interface Signals

The FC100/200 hardware signal pin assignments are shown in Figure 2. These signals are described in Table 5 and Table 6.

Facsimile Modem Interface Signals

R96DFXL (-CID) and R144EFXL pin assignments are shown in Figure 3. RFX96V24(-S) and RFX144V24(-S) hardware interface signals are shown in Figure 4. Pin assignments for the 28-pin XIA used with the RFX96V12-S and RFX144V12-S modems are shown in Figure 5.

The FE100/200(-M) device set package dimensions are shown in Figure 6 through Figure 8.

For additional information on these devices, refer to the specific product's Data Sheet or Designer's Guide.

Table 2. Documentation

Document	Order No.
R96DFXL MONOFAX Modem Data Sheet	MD92
R144EFXL MONOFAX Modem Data Sheet	MD90
RFX144V24-S and RFX96V24-S MONOFAX Modems Data Sheet	MD141
9600 bps MONOFAX Modem Designer's Guide	820
9600 bps MONOFAX Modem Designer's Guide--Addendum for R96DFXL	820A
R144EFXL MONOFAX Modem Designer's Guide	895
RFX144V24-S and RFX96V24-S MONOFAX Modems Designer's Guide	1070
MC24 Megacell CPU Programmer's Guide	415
eXtended Facsimile Controller (FC100/200) Hardware Description	1171
eXtended FAXENGINE Firmware Description	1139
FAXENGINE Evaluation System (FEES-X2) User's Manual	1066
MC24 FAXENGINE ROM Emulator System (MC24FERE) User's Manual	1016
MC24 Megacell CPU Programming Manual	415

Table 3. Environmental Specifications

Parameter	Specification
Temperature	
Operating	0°C to 70°C (32°F to 158°F)
Storage	-40°C to 80°C (-40°F to 176°F)
Relative Humidity	90% non-condensing, or a wet bulb temperature to 35°C, whichever is less.

Table 4. Power Requirements

Device	Voltage (Note 1)	Typical Current @25°C (Note 3)	Maximum Current @ 0°C (Note 3)
FC100/200 Primary Power			
	+5 VDC +5%/-10%	65 ma	70 ma
FE100/200-M Primary Power			
	+5 VDC +5%/-10%	67 ma	72 ma
FC100/200-M Battery Power and RTC (Note 2)			
	+5 VDC	17 µA	20 µA
	+3 VDC	5 µA	5.5 µA
MONOFAX Modems			
R96DFXL	+5 VDC ±5%	50 ma	55 ma
R144EFXL	+5 VDC ±5%	54 ma	60 ma
RFX96V24	+5 VDC ±5%	100/2 ma	119/2.5 ma
RFX96V24-S	+5 VDC ±5% (Note 4)	124/2.15 ma	149/2.8 ma
RFX144V24	+5 VDC ±5%	100/2 ma	119/2.5 ma
RFX144V24-S	+5 VDC ±5% (Note 4)	124/2.15 ma	149/2.8 ma

Notes:

- Input voltage ripple ≤0.1 volts peak-to-peak. The amplitude of any frequency between 20 and 150 kHz must be less than 500 microvolts peak.
- Real-Time Clock (RTC) battery power measurements made with a 32.768 kHz crystal oscillator.
- Normal/Standby current.
- Modem and XIA combined.

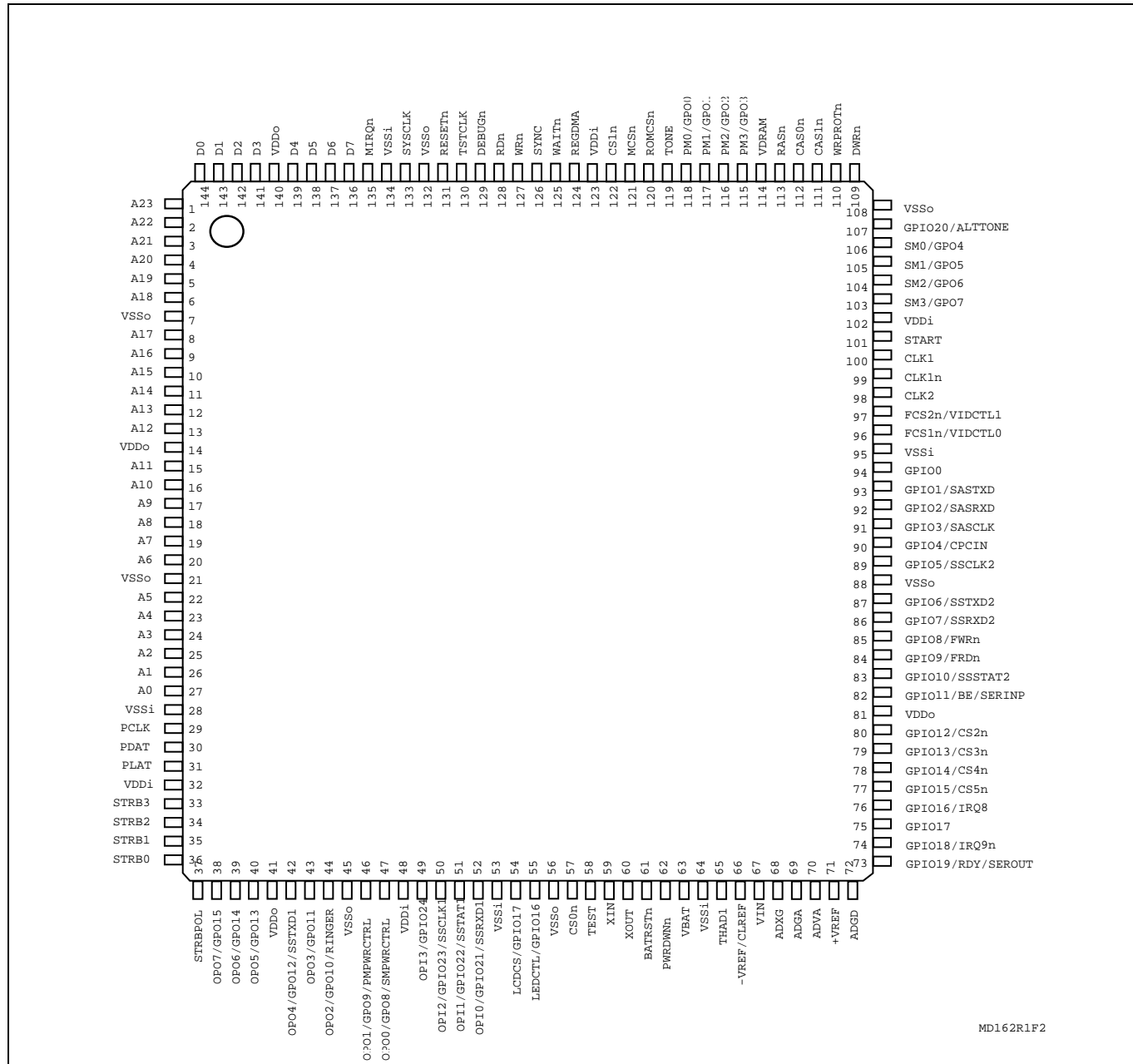

Figure 2. FC100/200 Pin Signals - 144-Pin TQFP

Table 5. FC100/200 Pin Assignments

Pin Name	Pin No.	I/O	Input Type	Output Type	Pin Description Note: Active low signals have an "n" pin name ending.
CPU Control Interface					
MIRQn	135	I	HU	--	Modem interrupt, active low. (Hysteresis In, Internal Pullup.)
SYSCLK	133	I	H	--	System clock. (Hysteresis In.)
TSTCLK	130	O	--	123XT	Test clock.
Bus Control Interface					
A[23:0]	[1:6][8:13] [15:20][22:27]	O	TU	123XT	Address bus (24-bit).
D[7:0]	[136:139] [141:144]	I/O	TU	123XT	Data bus (8-bit).
RDn	128	O	--	123XT	Read strobe.
WRn	127	O	--	123XT	Write strobe.
ROMCSn	120	O	--	123XT	ROM chip select.
CS1n	122	O	--	123XT	I/O chip select.
CS0n	57	O	--	123XT	SRAM chip select. (Battery powered.)
MCSn	121	O	--	123XT	Modem chip select.
SYNC	126	O	--	123XT	Indicates CPU op code fetch cycle (active high).
REGDMA	124	O	--	123XT	Indicates REGSEL cycle and DMA cycle.
WAITn	125	O	--	123XT	Indicates current TSTCLK cycle is a wait state or a halt state.
RASn	113	O	-	123XT	DRAM row address select. (Battery powered.)
CAS[1:0]n	[111:112]	O	-	123XT	DRAM column address select. (Battery powered.)
DWRn	109	O	-	123XT	DRAM write. (Battery powered.)
Prime Power Reset Logic and Test					
DEBUGn	129	I	HU	--	External non-maskable input (NMI).
RESETn	131	I/O	HU	2XO	FC100/200 Reset.
TEST	58	I	C	--	Sets Test mode (battery powered).
Battery Power Control and Reset Logic					
XIN	59	I	OSC	--	Crystal oscillator input pin.
XOUT	60	O	--	OSC	Crystal oscillator output pin.
PWRDWNn	62	I	H	--	Used by external system to indicate to FC100/200 loss of prime power. (Results in NMI).
BATRSTn	61	I	H	--	Battery power reset input.
WRPROTn	110	O	--	1XC	(Battery powered.) Write protect during loss of VDD power. NOTE: The functional logic is powered by battery power, but the output drive is powered by DRAM battery power.
Scanner Interface					
START	101	O	--	2XS	Scanner shift gate control.
CLK1	100	O	--	2XS	Scanner clock.
CLK1n	99	O	--	2XS	Scanner clock-inverted.
CLK2	98	O	--	2XS	Scanner reset gate control (or clock for CIS scanner).
FCS1n/VIDCTL0	96	O	--	2XT	Flash memory chip select or Video Control signal.
FCS2n/VIDCTL1	97	O	--	2XT	Flash memory chip select or Video Control signal.

Table 5. FC100/200 Pin Assignments (Cont'd)

Pin Name	Pin No.	I/O	Input Type	Output Type	Pin Description
Printer Interface					
PCLK/DMAACK	29	O	--	3XC	Thermal Print Head (TPH) clock or external DMAACK.
PDAT	30	O	--	2XP	Serial printing data (to TPH).
PLAT	31	O	--	3XP	TPH data latch.
STRB[3:0]	[33:36]	O	--	1XP	Strobe signals for the TPH.
STRBPOL/DMAREQ	37	I	C	--	Sets strobe polarity, active high/low.
Scanner Interface					
OPO[5]/GPO[13]	40	O	--	2XL	Keyboard / LED strobe [5] or GPO[13]
OPO[6]/ GPO[14]	39	O	--	2XL	Keyboard / LED strobe [6] or GPO[14]
OPO[7]/GPO[15]	38	O	--	2XL	Keyboard / LED strobe [7] or GPO[15]
OPI[0]/ GPIO[21]/ SSRXD1	52	I/O	HU	2XC	(Pullup, Hysteresis In) Keyboard return [0] or GPIO[21] or SSRXD1 (for SSIF1)
OPI[1]/ GPIO[22]/ SSSTAT1	51	I/O	HU	2XC	(Pullup, Hysteresis In) Keyboard return [1] or GPIO[22] or SSSTAT1 (for SSIF1)
OPI[2]/GPIO[23]/ SSCLK1	50	I/O	HU	2XC	(Pullup, Hysteresis In) Keyboard return [2] or GPIO[23] or SSCLK1 (for SSIF1)
OPI[3]/GPIO[24]	49	I/O	HU	2XC	(Pullup, Hysteresis In) Keyboard return [3] or GPIO[24]
LEDCTL	55	O	--	4XC	Indicates outputs OPO[7:0] are for LEDs.
LCDCS	54	O	--	1XC	LCD chip select.
General Purpose I/O					
GPIO[0]	94	I/O	H	2XC	(Hysteresis In) GPIO[0].
GPIO[1]/SASTXD	93	I/O	H	2XC	(Hysteresis In) GPIO[1] or SASTXD (for SASIF).
GPIO[2]/SASRXD	92	I/O	H	2XC	(Hysteresis In) GPIO[2] or SASRXD (for SASIF).
GPIO[3]/SASCLK	91	I/O	H	2XC	(Hysteresis In) GPIO[3] or SASCLK (for SASIF) .
GPIO[4]/CPCIN	90	I/O	H	2XC	(Hysteresis In) GPIO[4] or Calling Party Control Input
GPIO[5]/SSCLK2	89	I/O	H	2XC	(Hysteresis In) GPIO[5] or SSCLK2 (for SSIF2).
GPIO[6]/SSTXD2	87	I/O	H	2XC	(Hysteresis In) GPIO[6] or SSTXD2 (for SSIF2).
GPIO[7]/SSRXD2	86	I/O	H	2XC	(Hysteresis In) GPIO[7] or SSRXD2 (for SSIF2) .
GPIO[8]/FWRn	85	I/O	H	2XC	(Hysteresis In) GPIO[8] or flash write enable signal for NAND-type flash memory.
GPIO[9]/FRDn	84	I/O	H	2XC	(Hysteresis In) GPIO[9] or flash read enable signal for NAND-type flash memory.
GPIO[10]/ SSSTAT2	83	I/O	H	2XC	(Hysteresis In) GPIO[10] or SSSTAT2 (for SSIF2).
GPIO[11]/BE/ SERINP	82	I/O	H	1XC	(Hysteresis In) GPIO[11] or bus enable or serial port data input for autobaud detection.

Table 5. FC100/200 Pin Assignments (Cont'd)

Pin Name	Pin No.	I/O	Input Type	Output Type	Pin Description
General Purpose I/O (Cont'd)					
GPIO[12]/CS[2]n	80	I/O	H	2XC	(Hysteresis In) GPIO[12] or I/O chip select [2].
GPIO[13]/CS[3]n	79	I/O	H	2XC	(Hysteresis In) GPIO[13] or I/O chip select [3].
GPIO[14]/CS[4]n	78	I/O	H	2XC	(Hysteresis In) GPIO[14] or I/O chip select [4].
GPIO[15]/CS[5]n	77	I/O	H	2XC	(Hysteresis In) GPIO[15] or I/O chip select [5].
GPIO[16]/IRQ[8]	76	I/O	H	1XC	(Hysteresis In) GPIO[16] or external interrupt 8.
GPIO[17]	75	I/O	H	1XC	(Hysteresis In) GPIO[17]
GPIO[18]/IRQ[9]n	74	I/O	H	1XC	(Hysteresis In) GPIO[18] or external interrupt 9.
GPIO[19]/RDY/ SEROUT	73	I/O	H	1XC	(Hysteresis In) GPIO[19] or ready signal or Serial port data output for autobaud detection.
GPIO[20]/ ALTTONE	107	I/O	H	1XC	(Hysteresis In) GPIO[20] or ALTTONE.
Miscellaneous					
SM[3:0]/GPO[7:4]	[103:106]	O	--	1XC	Programmable: scan motor control pins or GPO pins.
PM[3:0]/GPO[3:0]	[115:118]	O	--	1XC	Programmable: print motor control pins or GPO pins.
TONE	119	O	--	1XC	Tone output signal.
Power, Reference Voltages, Ground					
-Vref/CLREF	66	I	-VR	--	Negative Reference Voltage for Video A/D or Reference Voltage for the Clamp Circuit
ADXG	68	I	VXG	--	A/D Internal GND. (NOTE: This pin requires an external 0.22µF decoupling capacitor to ADGA.)
ADGA	69		VADG		A/D Analog Ground
ADVA	70		VADV		A/D Analog Power
ADGD	72		VADG		A/D Digital Ground
+Vref	71	I	+VR		Positive Reference Voltage for Video A/D.
VIN	67	I	VA	--	Analog Video A/D input.
THADI	65	I	TA	--	Analog Thermal A/D input.
Power and Ground					
VSS(12)	7, 21, 28, 45, 53, 56, 64, 88, 95, 108, 132, 134				Digital Ground
VDD (8)	14, 32, 41, 48, 81, 102, 123, 140				Digital Power
VBAT	63				Battery Power
VDRAM	114				DRAM Battery Power

Table 6. FC100/200 Hardware Signal Characteristics

Input Signal Characteristics						
Input Type	Description	VIL (V max)	VIH (V min)	Hysteresis (V min)	Pullup Resistance (K ohm)	
C	CMOS Input	0.3*VDD	0.7*VDD	--	--	
H	Hysteresis	0.3*VDD	0.6*VDD	1.0	--	
HU	Hysteresis/Pullup	0.3*VDD	0.6*VDD	1.0	35–150	
T	TTL Input	0.8	2.0	--	--	
TU	TTL/Pullup	0.8	2.0	--	35-150	
OSC	CMOS Input	0.3*VDD	0.7*VDD	--	--	
Absolute Input Range = 0.5 to VDD+0.5						
Input Type	Description	Operating (V min)	Operating (V max)	Abs. Max. (V min)	Abs. Max. (V max)	
TA	Thermal Head Analog Input	0.2*VDD	0.8*VDD	-0.5	VDD+0.5	
VA	Video Analog In	-VR	+VR	-0.5	VADV + 0.5	
+VR	Video A/D +Vref	0.8	3.3	-0.5	VADV + 0.5	
-VR	Video A/D -Vref	-0.2	2.0	-0.5	VADV + 0.5	
VXG	Video Internal Ground	--	--	--	--	
VADV	Video A/D Power	VDD-0.1	VDD + 0.1	-0.5	7.0	
VADG	Video A/D GND	-0.1	0.1	-0.5	0.5	
VDD	Digital Power	4.5	5.25	-0.5	7.0	
GND	Digital Ground	0	0	0	0	
VDRAM	Battery Power for DRAM	2.25	5.25	-0.5	7.0	
VBAT	Battery Power for RTC/SRAM	2.25	5.25	-0.5	7.0	
Output Signal Characteristics						
Output Type	Description	VOL (V max)	IOL (ma max)	VOH (V min)	IOH (ma max)	CL (pF max)
1XC	CMOS Output (1X)	0.4	1.6	VDD-1.5	1.6	50
1XP, 2XP	High Capacitance Driver	0.4	1.6	VDD-1.5	1.6	200
2XC	CMOS Output (2X)	0.4	3.5	VDD-1.5	3.5	50
2XT	TTL Output (2X)	0.4	4	2.4	4	50
2XS	CMOS Output (2X)	0.4	3.5	VDD-1.5 1.5	3.5 15	50 50
2XL	LED Driver	0.7	10	VDD-1.5	3.5	100
2XO	CMOS Output, Open Drain	0.4	3.5	N/A	N/A	50
3XC	CMOS Output (3X)	0.4	6	VDD-1.5	6	50
3XP	High Capacitance Driver (3X)	0.4	6	VDD-1.5	6	700
4XC	CMOS Output (4X)	0.4	12	VDD-1.0	12	50
123XT	1/2/3X (Tristate) Output	0.4	1.6/4/6	2.4	1.6/4/6	50

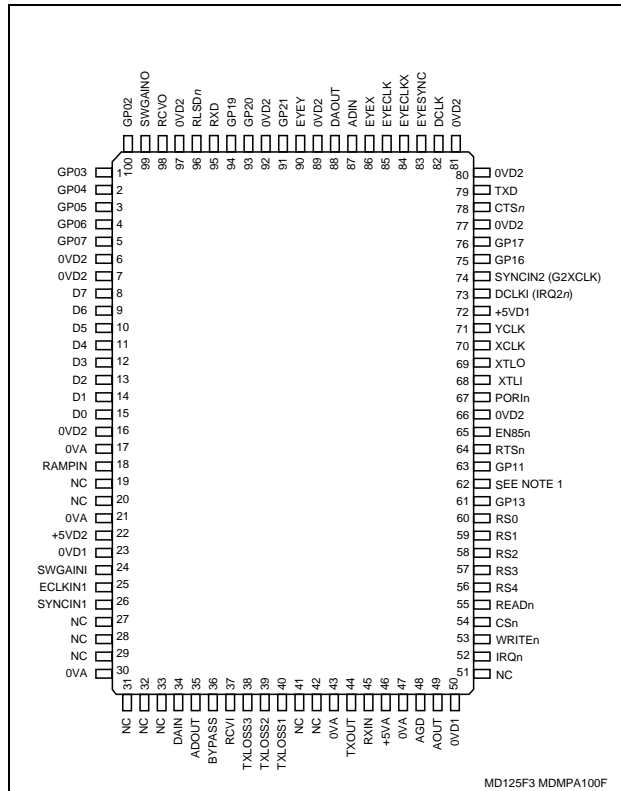

Notes:

1. For R96DFXL, connect pin 62 to +5VD1 or leave, open (nc);
For R144EFLX, connect pin 62 to +5VD1.
2. Names in parentheses apply to R144EFLX only.

Figure 3. R96DFXL and R144EFLX Facsimile Modem Pin Assignments

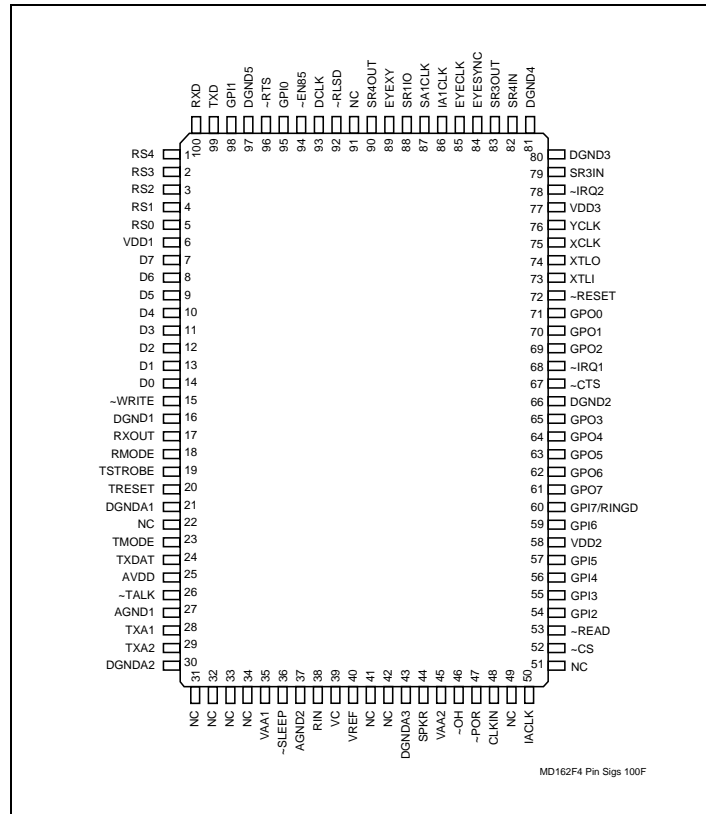

Figure 4. RFX96V24 (-S) and RFX144V24 (-S) Facsimile Modem Pin Assignments

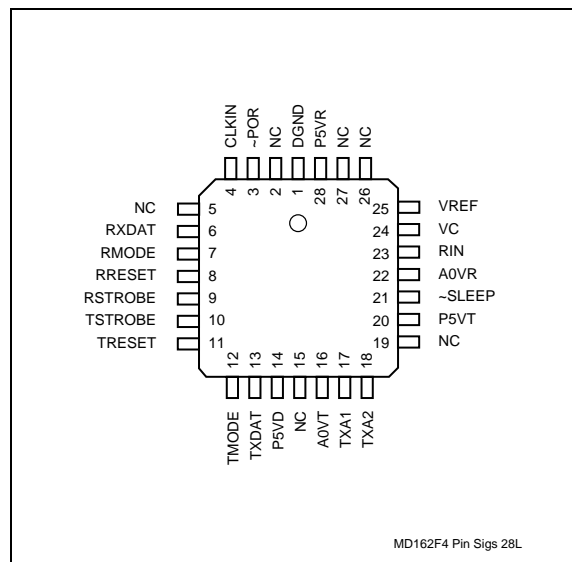

Figure 5. 28-Pin XIA Pin Signals

Software Description

Supplied Firmware

FAXENGINE firmware supplied with the FE100/200 consists of Core Code and Application Code. The Application Code, in conjunction with Core Code and FC100/200 (when connected to scanner and printer peripherals) provides a complete facsimile machine.

The Core Code (subdivided as Macro and Primitive functions) is supplied as object code, whereas the Application Code (to complete a fax machine) is supplied as assembly-level source code.

Core Code

The Core Code includes proprietary primitives and macros in object code form located in ROM at the top of the FAXENGINE processor address space. These Core Code primitives and macros provide the following functions:

- Modem control
- T.30 framing and control
- T.4 MH, MR and MMR control for FC100/200 and FC100/200-M compression/decompression hardware. Supports Line times of 5 ms per line.
- Send and receive a page
- Real-time multitasking executive for scheduling high priority (interrupt-driven) tasks and servicing low priority (background) tasks

The Core Code subroutines are organized in a modular layered structure that allows for replacement of any of these subroutines by OEM-written custom subroutines.

Core Code routines are organized in a library and the Core Code linkage routine optimizes ROM space code by preventing code duplication when Core Code routines are unused or replaced by Developer routines.

Application Code

The Application Code provides source assembly code for a complete facsimile machine application. The Application Code links to the Core Code functions to control the FAXENGINE peripheral functions. The Application Code performs customized functions to provide flexibility to enable the following:

- Scanner and printer control
- Operator panel control (Keypad, LED, LCD, Beeper)
- Scan document handling (pull-in and eject)

- Printer paper handling (eject and cut)
- Copy page
- Setup controls for the facsimile machine (date and time, header, transmit level)
- Call progress controls with parameter tables to allow modification for PTT requirements in different countries
- T.30 control by generating frame content and sequence used during a T.30 negotiation
- Fax/Voice discrimination with external answering machine interface

Conditional Assembly

Other supported functions included in the final object code (when the appropriate conditional assembly switches are enabled) are as follows:

- Error Correction Mode (ECM)
- Flash memory (Voice storage)
- Page Memory support that includes broadcast/delayed capabilities and receiving to memory
- Resolution conversion
- Multi-level and bi-level B4 to A4 reduction
- Digital answering machine support
- Full duplex digital speakerphone

The supplied firmware allows conditional inclusion of the following items, some of which automatically add other options, as noted:

- FC100/200 type (MMR and ACD option.)
- Modem type
- ECM RAM (and size of Comm Buffer)
- Speakerphone
- UART interface for debug
- Scan image processing enabled/disabled
- Line ORing enabled/disabled
- Call progress country
- Language for operator interface
- Fax mechanism. (Specifies parameter ranges for scanning and printing timing, scanner and printer width, shading correction and edge enhancement threshold value.)

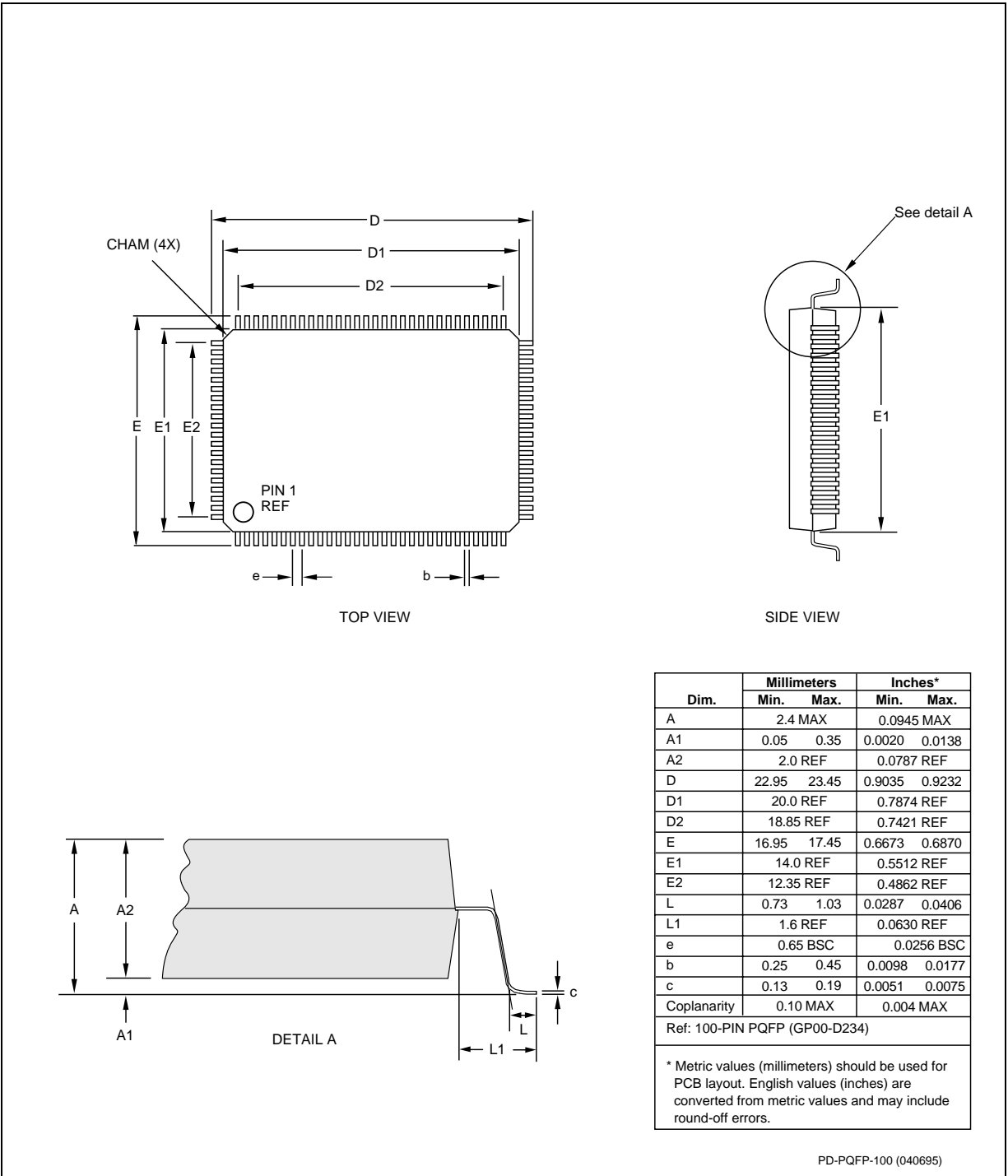

Figure 6. 100-Pin PQFP Dimensions

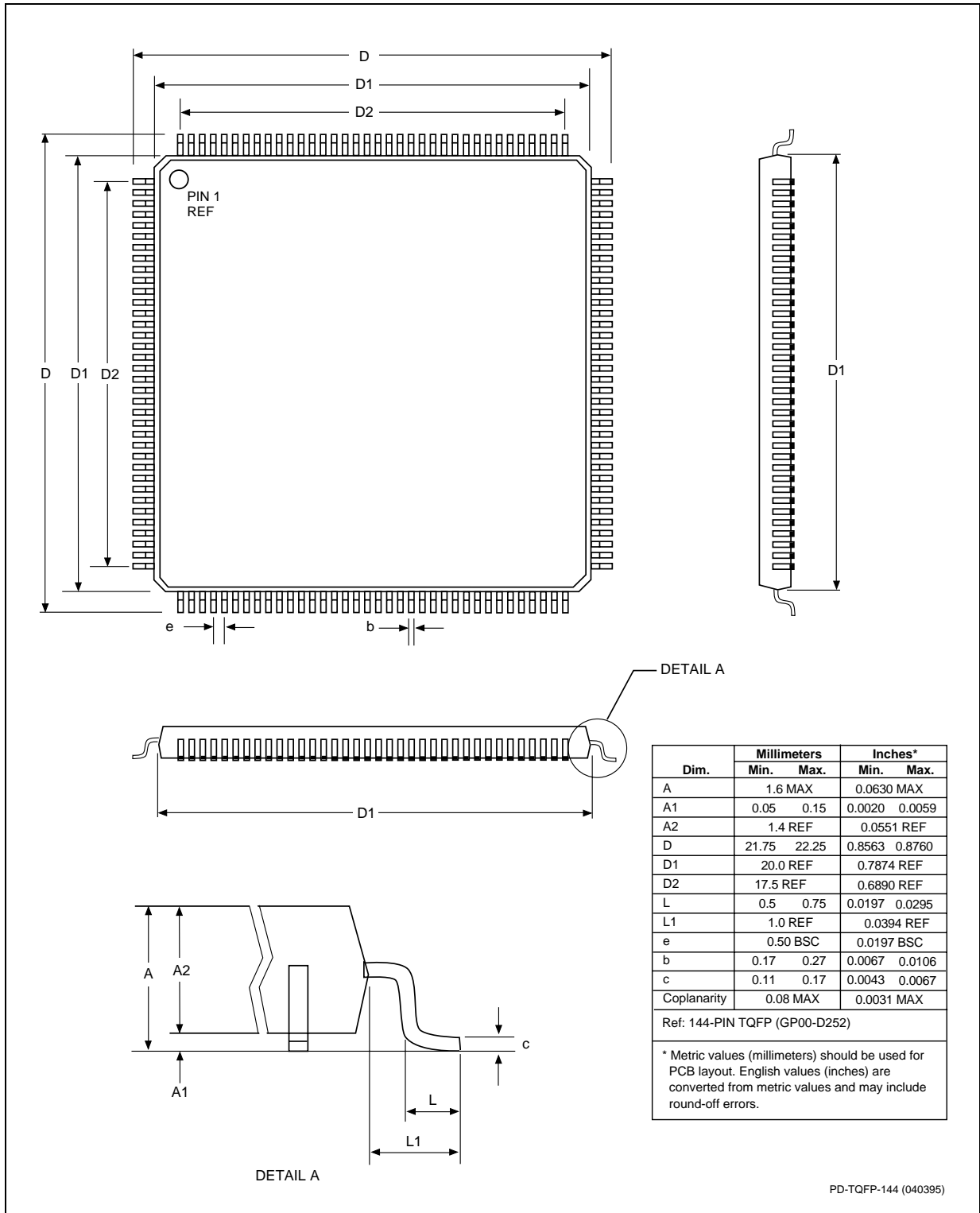

Figure 7. 144-Pin TQFP Dimensions

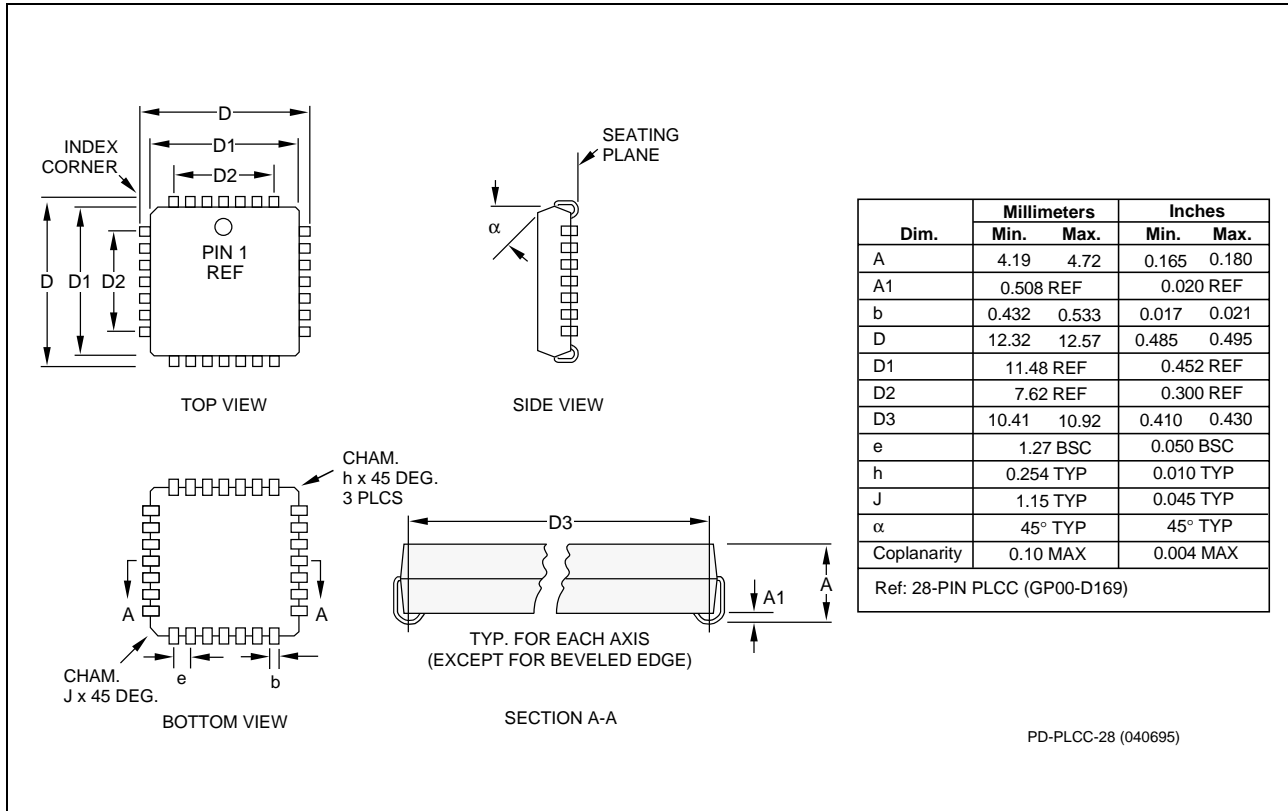

Figure 8. 28-Pin PLCC Dimensions



Further Information

literature@conexant.com
1-800-854-8099 (North America)
33-14-906-3980 (International)

Web Site

www.conexant.com

World Headquarters

Conexant Systems, Inc.
4311 Jamboree Road
P. O. Box C

Newport Beach, CA
92658-8902
Phone: (949) 483-4600
Fax: (949) 483-6375

U.S. Florida/South America
Phone: (813) 799-8406
Fax: (813) 799-8306

U.S. Los Angeles
Phone: (805) 376-0559
Fax: (805) 376-8180

U.S. Mid-Atlantic
Phone: (215) 244-6784
Fax: (215) 244-9292

U.S. North Central
Phone: (630) 773-3454
Fax: (630) 773-3907

U.S. Northeast
Phone: (978) 692-7660
Fax: (978) 692-8185

U.S. Northwest/Pacific West
Phone: (408) 249-9696
Fax: (408) 249-7113

U.S. South Central
Phone: (972) 773-0723
Fax: (972) 407-0639

U.S. Southeast
Phone: (770) 246-8283
Fax: (770) 246-0018

U.S. Southwest
Phone: (949) 222-9119
Fax: (949) 222-0620

APAC Headquarters

Conexant Systems Singapore,
Pte. Ltd.
1 Kim Seng Promenade
Great World City
#09-01 East Tower
Singapore 237994
Phone: (65) 737 7355
Fax: (65) 737 9077

Australia
Phone: (61 2) 9869 4088
Fax: (61 2) 9869 4077

China
Phone: (86 2) 6361 2515
Fax: (86 2) 6361 2516

Hong Kong

Phone: (852) 2827 0181
Fax: (852) 2827 6488

India

Phone: (91 11) 692 4780
Fax: (91 11) 692 4712

Korea

Phone: (82 2) 565 2880
Fax: (82 2) 565 1440

Europe Headquarters

Conexant Systems France
Les Taissounieres B1
1680 Route des Dolines
BP 283
06905 Sophia Antipolis Cedex
France

Phone: (33 4) 93 00 33 35
Fax: (33 4) 93 00 33 03

Europe Central

Phone: (49 89) 829 1320
Fax: (49 89) 834 2734

Europe Mediterranean

Phone: (39 02) 9317 9911
Fax: (39 02) 9317 9913

Europe North

Phone: (44 1344) 486 444
Fax: (44 1344) 486 555

Europe South

Phone: (33 1) 41 44 36 50
Fax: (33 1) 41 44 36 90

Middle East Headquarters

Conexant Systems Commercial
(Israel) Ltd.
P. O. Box 12660
Herzlia 46733, Israel
Phone: (972 9) 952 4064
Fax: (972 9) 951 3924

Japan Headquarters

Conexant Systems Japan Co.,
Ltd.
Shimomoto Building
1-46-3 Hatsudai,
Shibuya-ku, Tokyo
151-0061 Japan
Phone: (81 3) 5371 1567
Fax: (81 3) 5371-1501

Taiwan Headquarters

Conexant Systems, Taiwan Co.,
Ltd.
Room 2808, 333
International Trade Building
Keelung Road, Section 1
Taipei 110, Taiwan, ROC
Phone: (886 2) 2720 0282
Fax: (886 2) 2757 6760