

PRELIMINARY

CY7B4679

# 10BASE-T/10BASE-FL Media Converter

## Features

- Bidirectional 10BASE-T/10BASE-FL media conversion
- Maximum  $I_{CC}$  of 120 mA
- Maximum fiber-optic transmitter LED current 110 mA
- Fiber input sensitivity 2 mV<sub>p,p</sub> or better
- Low power BiCMOS design
- Conforms to IEEE 802.3
- Single 5 volt power supply
- Two network status LED outputs
- Well suited for repeater applications
- Advanced FiberAlert+ function
- Full duplex operation
- Media Link Passing
- 20-pin PLCC

## Functional Description

The CY7B4679 is a low power media converter designed to interface 10BASE-T and 10BASE-FL Ethernet systems. It combines the low cost of 10BASE-T with the long distance application of 10BASE-FL networks. This interface is seam-

lessly implemented and is directly compatible with both 10BASE-T and 10BASE-FL Ethernet networks. The CY7B4679 offers an integrated solution that requires a minimum of external components and is ideal for repeater applications.

The CY7B4679 10BASE-FL fiber-optic transmitter offers a fully fiber-optic differential current drive output which can directly drive a fiber-optic LED transmitter. The current drive level is adjustable to a maximum value of 110 mA. The CY7B4679 fiber-optic transmitter automatically inserts a 1-MHz link signal during idle time to preserve link integrity. The fiber-optic receiver offers a highly stable data quantizer which accepts input signals as low as 2 mV<sub>p,p</sub>. Two LED status indicators display the fiber and twisted-pair link status.

The 10BASE-T interface has automatic polarity detection and correction. The twisted-pair link integrity monitor has a 100-ms link integrity window. If a link integrity pulse is received before the timer expires the link status LED remains on and the timer is reset for another period. The CY7B4679 typically emits link integrity pulses on the 10BASE-T media every 10 ms if the fiber-optic 1-MHz link is functional, and vice versa. Additionally, the CY7B4679 has FiberAlert+ circuitry which can be used to inform the far end fiber connection a link fault has occurred.

## Logic Block Diagram

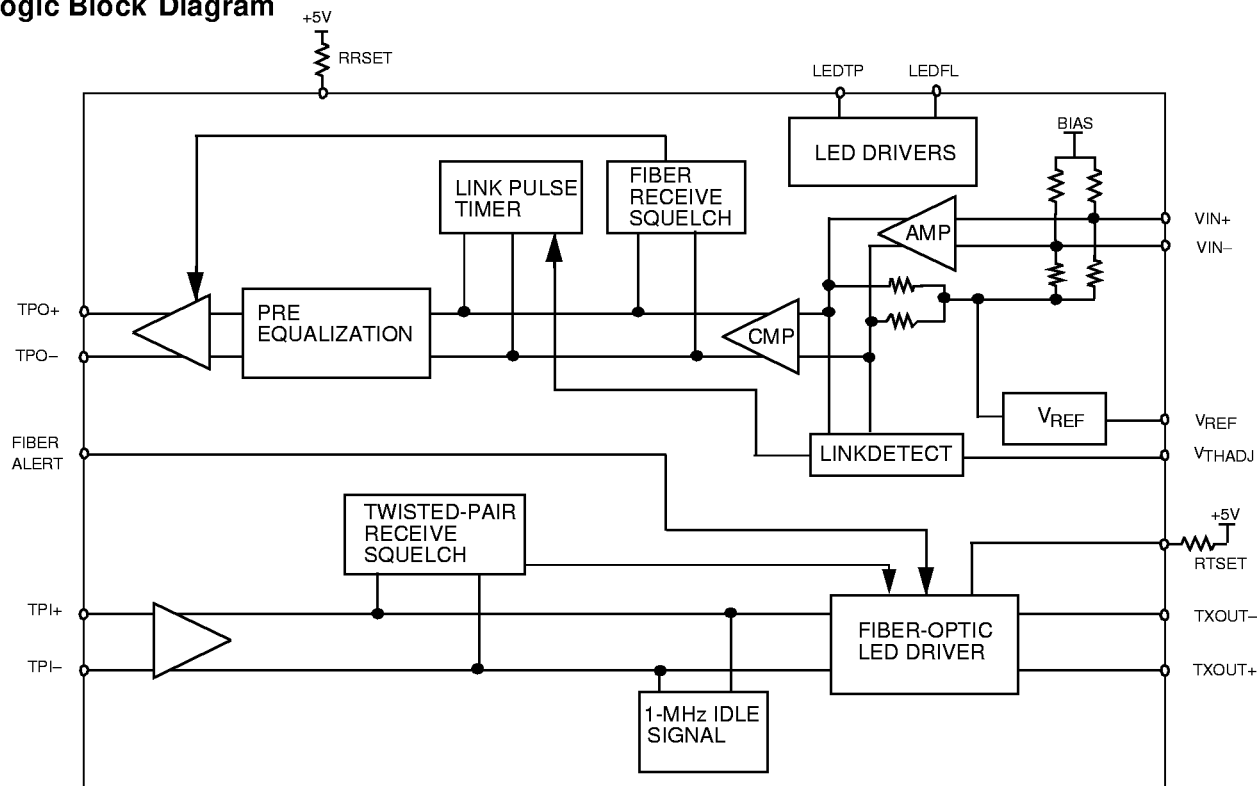

4679-1

## Pin Configuration

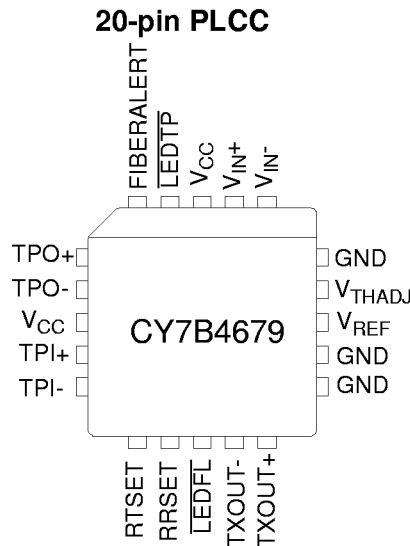

## Pin Descriptions

Pin Number	Name	Description
1	V <sub>CC</sub>	+5 volt power supply.
2	LEDTP	Active LOW LED pin that displays twisted-pair link status.
3	FIBERALERT	Connecting this pin to GND places the chip in IEEE compliant mode. Tying the pin to V <sub>CC</sub> enables the FiberAlert function which pulses the fiber transmitter on for 1s and off for 1s during a Link Fault condition.
4	TPO+	Balanced differential voltage drivers with pre-equalization.
5	TPO-	
6	V <sub>CC</sub>	+5 volt power supply.
7	TPI+	Twisted-pair receive inputs. When the input signal exceeds the receive squelch the receive data is buffered and sent to the fiber transmitter.
8	TPI-	
9	RTSET	A 1% 1kΩ resistor which sets the current driven output of the LED transmitter.
10	RRSET	A 1% 61.9kΩ resistor sets the internal node current.
11	LEDFL	An active LOW LED status pin that displays the fiber link status.
12	TXOUT-	The output current complement of TXOUT+. When shorted to V <sub>CC</sub> (TXOUT+ used single-ended) the internal current driver sourcing this pin is powered off.
13	TXOUT+	Fiber-optic LED driver output. Capable of driving 110 mA high power fiber transmitters.
14	GND	Ground reference.
15	GND	Ground reference.
16	V <sub>REF</sub>	A 2.5 V reference output.
17	V <sub>THADJ</sub>	Input pin which sets the internal link monitor threshold.
18	GND	Ground reference
19	V <sub>IN-</sub>	Fiber-optic receive inputs. Can be capacitively coupled to the fiber input source or to +5 volts
20	V <sub>IN+</sub>	

## CY7B4679 Description

The CY7B4679 contains seven main functional blocks:

1. Twisted-pair transmitter which takes data from the fiber-optic receiver and sends it onto twisted-pair cable.
2. Twisted-pair receiver which takes data from the twisted-pair media and sends it to the fiber transmitter.
3. Twisted-pair link integrity monitor with indicator LED that periodically tests the integrity of the twisted-pair link.
4. Receive polarity detector and correction control which detects the polarity of the received signal and internally corrects the polarity of a reversed polarity connection.
5. Fiber-optic transmitter which takes received data from twisted-pair media and sends it onto the fiber-optic cable.
6. Fiber-optic receiver that takes data from the fiber media and sends it to the twisted-pair transmitter.
7. Fiber media link detect circuit with link status LED. Also contains FiberAlert circuitry which is used to inform the far end fiber-optic connection that a link fault has occurred. The FiberAlert function can be disabled.

### Twisted-Pair Transmit Functions

The twisted-pair transmitter contains a fully balanced differential twisted-pair cable driver with internal pre-equalization. The transmitter squelch circuit prevents noise on the fiber network from driving the twisted-pair transmitter. The transmitter will be activated only if the signal at  $V_{IN\pm}$  exceeds the set threshold value and has a minimum frequency of 2.5 MHz.

Pre-equalization of the twisted-pair signal is achieved internally in the CY7B4679, eliminating the need for external resistor networks and minimizing the pin count. Pre-equalization is designed to reduce the frequency dependent jitter caused by the inherent low pass characteristics of the twisted-pair cable. The signal is emphasized for the first 40 ns following a voltage transition, while the following 60 ns are not. The transmitter is capable of driving 100 meters of UTP cable using a 1:2 transformer.

### Twisted-Pair Receive Functions

The CY7B4679 twisted-pair receiver transfers data from the twisted-pair media to the fiber-optic transmitter. The twisted-pair receive ports are connected through a standard 1:1 transformer to the twisted-pair cable. The CY7B4679 receiver has a high differential input impedance to allow external resistors to accurately match the twisted-pair cable impedance.

The CY7B4679 has a squelch circuit that prevents noise on the twisted-pair media from entering the fiber transmit circuitry. The receiver will power up if the differential voltage exceeds 400 mV and has a low-high-low sequence with the positive and negative pulse widths exceeding 50 ns. The receiver is deactivated by a continuous HIGH which exceeds 150 ns. The receiver is then inhibited for 700 ns to prevent dribble bit propagation.

### Twisted-pair Link Detection

The CY7B4679 link detection circuit monitors the integrity of the twisted-pair cable connected to the TPI ports. If a fault occurs, the transmit and receive functions are disabled and the LEDTP pin is placed HIGH to shut off the twisted-pair link status LED.

The integrity monitoring of the connection at TPI pins is achieved by detecting periodic link integrity pulses. When no data frames are being received a link integrity window is set by the converter. The link integrity window typically starts 2.5 ms after the end of a packet reception or link pulse and lasts for 50 ms. If a 100-ns link integrity pulse is received in the 2.5 ms period between the end of a packet or link pulse and the opening of the link integrity window it is ignored. If a link integrity pulse is received between the 2.5-ms and 50 ms window the link integrity timer resets and another 50 ms window is opened. If neither a link integrity pulse nor a data packet is received within the 50-ms window then the twisted-pair receive circuit is powered down and the twisted-pair link status LED (LEDTP) goes to high impedance. At the same time the 1-MHz link signal is turned off and the CY7B4679 fiber transmitter is disabled. In order for the CY7B4679 to leave the Link Test Fail mode two consecutive link pulses at least 2.5-ms apart or a data packet need to be received within a 50-ms period. The CY7B4679 typically sends out a 100 ns link integrity pulse on the TPO± ports every 10 ms.

### Polarity Detection/Correction

The CY7B4679 twisted-pair receiver has a polarity detector and correction circuit. The polarity detector is activated upon power-up or after a link failure. To determine the correct polarity the CY7B4679 requires either seven consecutive link pulses of the same polarity or a data packet transmission. After determining the correct polarity the correction circuit provides this information to the fiber-optic driver and link integrity circuitry.

### Fiber Transmit Function

The fiber transmitter translates twisted-pair receive data to the fiber media. TPI+ positive with respect to TPI- results in TX-OUT+ being high impedance and no current flowing through the transmitter. This places the fiber LED in a non-transmitting state. When TPI+ is negative with respect to TPI- then TX-OUT+ will sink current into the CY7B4679 and the fiber LED transmitter will light up. When in the non-transmitting state the CY7B4679 will transmit a 1-MHz link signal over the fiber network to maintain link integrity.

The fiber LED drive current is set by the value of resistor connected to the RTSET pin. The drive current is set using the following equation

$$RTSET = (52\text{mA}/I_{OUT})1\text{k}\Omega$$

where  $I_{OUT}$  is the desired fiber LED current drive. The fiber transmitter is capable of sinking up to 110 mA of current, making it compatible with high powered 100 mA LEDs in addition to standard 60 mA LEDs. The CY7B4679 also has TXOUT- which is the complement of TXOUT+. This allows for true differential driving of a fiber-optic transmitter. If TXOUT- is connected to  $V_{CC}$  the internal current driver sourcing this pin will power off for single ended applications.

In order for data to be transferred from the twisted-pair receive ports to the fiber outputs it must meet the twisted-pair to fiber squelch requirements. At the end of a packet, the fiber transmitter transitions to a 1-MHz link signal if a 150-ns continuous HIGH (or LOW in the case of reversed polarity) is detected on the twisted-pair.

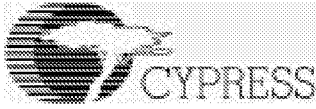

### Fiber Receive Function

The fiber receiver takes data from the fiber-optic media and passes it to the twisted-pair transmitters. The CY7B4679 receive squelch prevents signal with frequencies lower than 2.5 MHz from being passed to the twisted-pair transmitters.

The  $V_{THADJ}$  pin can be used to adjust the sensitivity of the fiber receiver.  $V_{THADJ}$  can be tied directly to  $V_{REF}$  and achieve a bit error ratio (BER) of less than  $10^{-10}$ . If greater sensitivity is desired a voltage divider can be used to adjust  $V_{THADJ}$ . The relationship between  $V_{THADJ}$  and  $V_{TH}$  (the quantizer input threshold) is:

$$V_{THADJ} = 400V_{TH}$$

### Fiber Media Link Circuit

The CY7B4679 is designed to act as a transparent media converter. Twisted-pair link integrity pulses are translated to 1-MHz fiber link signal, and vice versa. When pin 3 (FiberAlert) is LOW each media interface will comply with its section of the IEEE 802.3 standard.

With pin 3 LOW, if the input signal at the fiber-optic receiver falls below  $-32.5$  dBm (560 nW) for more than 2000 BT the link monitor circuitry will send the CY7B4679 into Low Light state. In the Low Light state the twisted-pair transmitter is disabled and discontinues link signaling. The fiber transmitter will continue to pass signals received at  $TPI_{\pm}$ . LEDFL goes high impedance, turning off the fiber link LED. To return to the Link Pass state the optical power level at the fiber-optic receiver must exceed the shut off level by 20%. Once the receive power exceeds this threshold, the CY7B4679 waits 300 to 600 ms before exiting the Link Fail state and entering the Link Test Pass state.

The CY7B4679 also implements marginal light circuitry to meet IEEE compliance. Marginal light mode is entered if the optical receive average power maintains a value below  $-30$  dBm for 2000 BT. If the optical receive average power then falls below the level that corresponds to a BER of  $10^{-10}$  for 500 BT the Low Light state is entered. The marginal light threshold is determined assuming the voltage at  $V_{THADJ}$  corresponds to a receive threshold of  $-32.5$  dBm. The CY7B4663 internally sets a threshold 78% above  $V_{TH}$  (The internal threshold) corresponding to the difference between  $-30$  and  $-32.5$  dBm.

### FiberAlert

If pin 3 is connected to  $V_{CC}$ , the CY7B4679 FiberAlert+ circuitry is activated. This alters the function of the fiber link circuitry, and can be best described on a case by case basis.

If (with FiberAlert+ active) the fiber receive optics go dark two things occur: (1) The twisted-pair transmitter stops sending link integrity pulses on  $TPO_{\pm}$ ; and (2) the fiber transmitter will pulse the 1-MHz link signal, alternating one second of transmission with one second of silence.

Upon a loss of link integrity pulses at the twisted-pair interface while the fiber receive is in Link Pass the fiber transmitter goes dark (no link signal) regardless of the status of pin 3.

In the case that both twisted-pair and fiber link integrity are lost, the chip maintains the mode entered first. that is, if the twisted-pair link integrity is fine and the fiber link is lost, the fiber transmitter will begin to pulse the 1-MHz link signal. If the twisted-pair link is then lost, the CY7B4679 will continue to pulse the 1-MHz link signal. Similarly, if the fiber receive is fine and the twisted-pair link is lost, the fiber transmitter will go dark and the 1-MHz link signal halted. If the fiber link monitor then indicates that the fiber receiver has entered Link Loss the fiber transmitter will remain dark.



**Maximum Ratings**

(Above which the useful life may be impaired. For user guidelines, not tested.)

Storage Temperature ..... -65°C to +150°C  
 Ambient Temperature with  
 Power Applied ..... -55°C to +125°C  
 Supply Voltage ..... -0.5V to +7.0V

DC Input Voltage ..... -3.0V to +7.0V

**Operating Range**

Range	Ambient Temperature	V <sub>CC</sub>
Commercial	0°C to +70°C	5V ± 10%

**Electrical Characteristics** Over the Operating Range

Parameter	Description	Min.	Typ.	Max.	Unit
V <sub>CC</sub>	Supply Voltage	4.50	5.00	5.50	V
V <sub>CL</sub>	Indicator LED Output LOW (I <sub>OL</sub> =10 mA)			0.8	V
I <sub>CC1</sub>	Supply Current Non-Transmitting		45	70	mA
I <sub>CC2</sub>	Supply Current Transmitting (Both 10BASE-T and FL; RTSET=1 kΩ)			120	mA
I <sub>FTOP</sub>	Fiber Transmit Output Precision (RTSET=1 kΩ)	47	52	57	mA
I <sub>FTP</sub>	Maximum Transmit Current		110		mA
V <sub>CM</sub>	Optical Common Mode Voltage (V <sub>IN±</sub> )		2.5		V
V <sub>REF</sub>	Reference Voltage	2.35	2.45	2.55	V
I <sub>THADJ</sub>	Input Bias Current at V <sub>THADJ</sub>	-200	0	200	μA
V <sub>IN</sub>	Optical Input Signal Range	2		1600	mV
R <sub>IN</sub>	Input Resistance (V <sub>IN±</sub> )	0.8	1.3	2.0	kΩ
V <sub>T</sub>	Input Threshold for Switching from Link Pass to Link Fail	5	6	7	mV <sub>p-p</sub>
V <sub>TPH</sub>	TPO± Output High Voltage		3.75		V
V <sub>TPL</sub>	TPO± Output Low Voltage		1.25		V
V <sub>TCM</sub>	Twisted-pair Common Mode Voltage (TPO±)		2.5		V
I <sub>TPI</sub>	Twisted-pair Transmit Current		50		mA
V <sub>TPRS</sub>	Twisted-pair Receive Squelch Threshold	±325		±575	mV
R <sub>TPO</sub>	TPO± Output Resistance (I=50 mA)		5	10	Ω
R <sub>TPI</sub>	TPI± Differential Input Resistance	15			kΩ

**Switching Characteristics** Over the Operating Range

Parameter	Description	Min.	Typ.	Max.	Unit
<b>Twisted-Pair Receive to Fiber Transmit</b>					
t <sub>TFPW</sub>	Optical Transmit Turn-Off Pulse Width Data to Idle	400	700	2100	ns
t <sub>TODY</sub>	TP to Fiber Transmit Turn-On Delay			4BT	bit period
f <sub>TIDL</sub>	Optical Transmit Idle Frequency	0.85	1.00	1.25	MHz
t <sub>TDC</sub>	Optical Transmit Idle Duty Cycle	45		55	%
t <sub>TPFJ</sub>	Fiber Jitter into 31Ω Load		±1.0		ns
t <sub>PDTPF</sub>	Propagation Delay TP to Fiber		25	40	ns
<b>Fiber Receive to TP Transmit</b>					
t <sub>TSD</sub>	Fiber to TP Transmit Start-Up Delay		1BT	2BT	bit period
t <sub>TD</sub>	Fiber to TP Propagation Delay		25	40	ns
t <sub>TSJ</sub>	Fiber to TP Transmitter Added Jitter		±2.5		ns
t <sub>THI</sub>	TP Transmitter High to Idle Time	250		450	ns



**Switching Characteristics** Over the Operating Range (continued)

Parameter	Description	Min.	Typ.	Max.	Unit
$t_{TST}$	Link Transmit Silence Time	8	10	24	ms
$t_{LPW}$	Link Pulse Period	80	100	120	ns
$t_{ICLP}$	Time Period for Ignored Consecutive Link Pulses	2		7	ms
$t_{CCLP}$	Time Period for Counted Consecutive Link Pulses	25		150	ms
$t_{LDTS}$	Minimum Link Loss Detect Time		50		ms
$t_{LDTM}$	Maximum Link Loss Detect Time		100		ms
$t_{RSFT}$	Receive Squelch Frequency Threshold	1.85		2.75	MHz

**Switching Waveforms**

**Twisted-Pair to Fiber Transmit Timing**

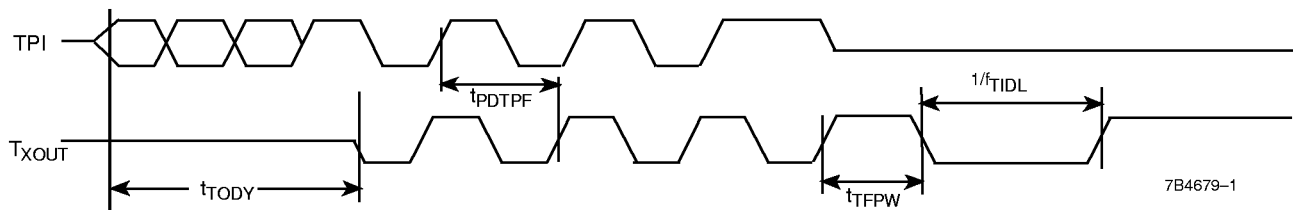

**Fiber Receive to Twisted-Pair Transmit Timing**

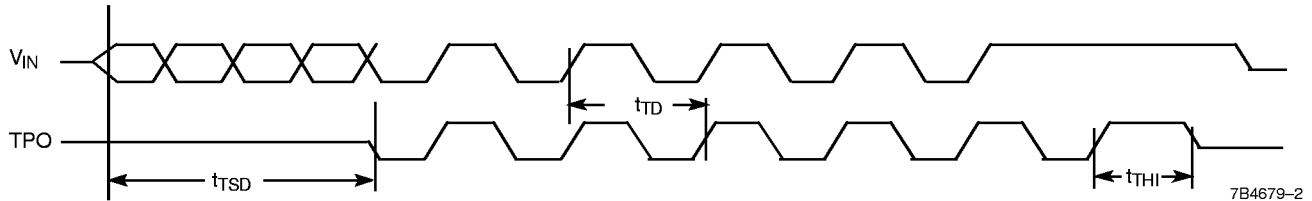

**Fiber Receive to Twisted-Pair Link Test Timing**

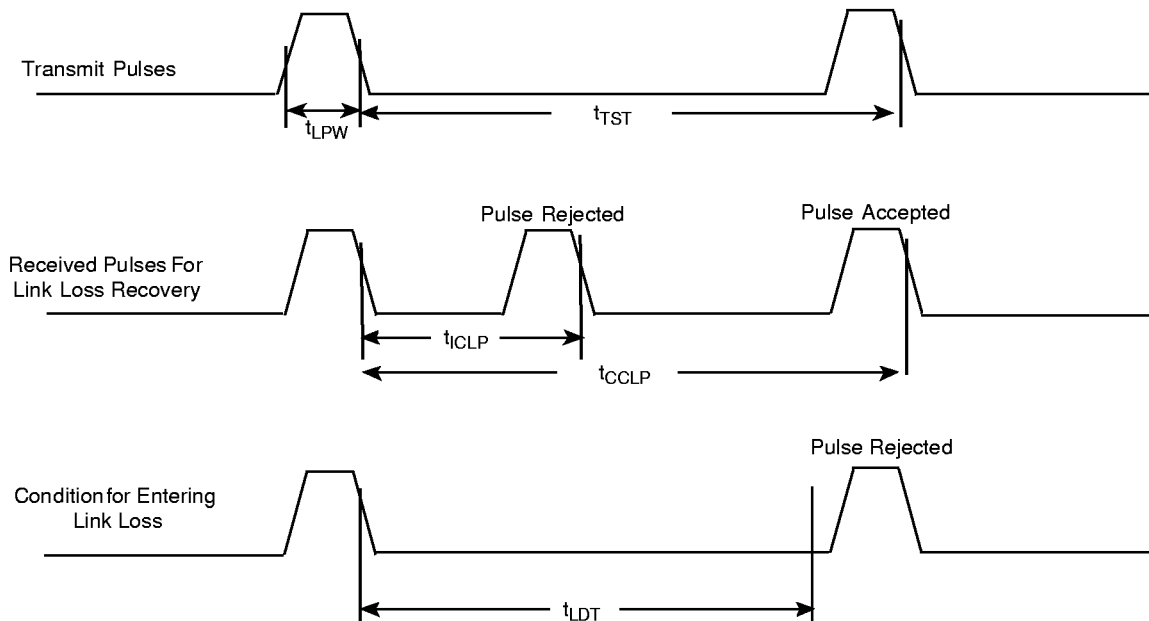



Ordering Information

Ordering Code	Package Name	Package Type	Operating Range
CY7B4679-JC	J61	20-Lead Plastic Leaded Chip Carrier	Commercial

Document #: 38-00514-B

Package Diagram

20-Lead Plastic Leaded Chip Carrier J61

DIMENSIONS IN INCHES MIN. MAX.

