

040674

HS-C²MOS™ INTEGRATED CIRCUITS

PRELIMINARY DATA

8-BIT EQUALITY COMPARATOR

DESCRIPTION

The M54/74HC688 utilizes silicon gate C²MOS technology to achieve operating speeds equivalent to LSTTL parts. Along with the low power dissipation and high noise immunity of standard C²MOS integrated circuit, it possesses the driving capability of 10 LSTTL load. The M54/74HC688 compares bit for bit two 8-bit words applied on inputs P₀ - P₇ and inputs Q₀ - Q₇ and indicates whether or not they are equal. A single active low enable is provided to facilitate cascading of several packages to enable comparison of words greater than 8 bits. All inputs are equipped with protection circuit against static discharge or transient excess voltage.

B1 Plastic Package **F1** Ceramic Package **C1** Chip Carrier

ORDERING NUMBERS: M54HC688 F1
M74HC688 B1
M74HC688 F1
M74HC688 C1

FEATURES

- High Speed
t_{PD} = 21 ns (Typ.) at V_{CC} = 5V
- Low Power Dissipation
I_{CC} = 4 μA (Max.) at T_A = 25°C
- High Noise Immunity
V_{NIH} = V_{NIL} = 28% V_{CC} (Min.)
- Output Drive Capability
10 LSTTL Loads
- Symmetrical Output Impedance
|I_{OH}| = I_{OL} = 4 mA (Min.)
- Balanced Propagation Delays
t_{PLH} = t_{PHL}
- Wide Operating Voltage Range
V_{CC} (opr) = 2V to 6V
- Pin and Function compatible
with 54/74LS688

TRUTH TABLE

INPUT			OUTPUT
P, Q	\bar{G}		$\bar{P} = \bar{Q}$
P = Q	L		L
P ≠ Q	L		H
*	H		H

*: Don't care

PIN CONNECTIONS (top view)

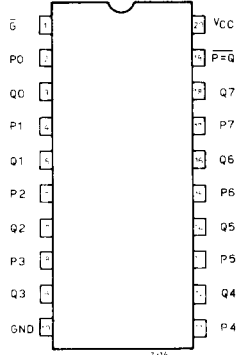

Dual in line

CHIP CARRIER

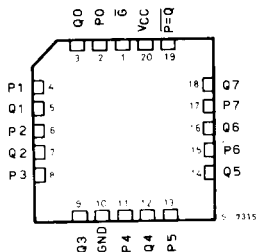

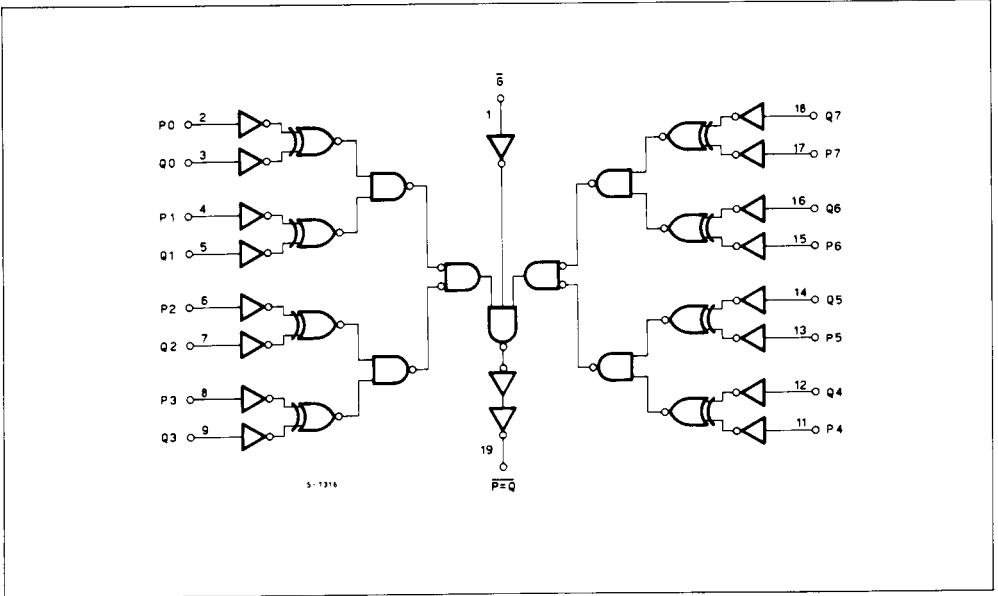
LOGIC DIAGRAM

ABSOLUTE MAXIMUM RATINGS

Symbol	Parameter	Value	Unit
V_{CC}	Supply Voltage	- 0.5 to 7	V
V_I	DC Input Voltage	- 0.5 to $V_{CC} + 0.5$	V
V_O	DC Output Voltage	- 0.5 to $V_{CC} + 0.5$	V
I_{IK}	DC Input Diode Current	± 20	mA
I_{OK}	DC Output Diode Current	± 20	mA
I_O	DC Output Source Sink Current Per Output Pin	± 25	mA
I_{CC} or I_{GND}	DC V_{CC} or Ground Current	± 50	mA
P_D	Power Dissipation	500 (*)	mW
T_{stg}	Storage Temperature	- 65 to 150	$^{\circ}C$

Absolute Maximum Ratings are those values beyond which damage to the device may occur. Functional operation under these conditions is not implied.

(*) 500 mW: $\cong 65^{\circ}C$ derate to 300 mW by 10 mW/ $^{\circ}C$: $65^{\circ}C$ to $85^{\circ}C$.



RECOMMENDED OPERATING CONDITIONS

Symbol	Parameter	Limit	Unit
V_{CC}	Supply Voltage	2 to 6	V
V_I	Input Voltage	0 to V_{CC}	V
V_O	Output Voltage	0 to V_{CC}	V
T_A	Operating Temperature 74HC Series 54HC Series	- 40 to 85 - 55 to 125	°C
t_r, t_f	Input Rise and Fall Time	$V_{CC} \begin{cases} 2 \text{ V} & 0 \text{ to } 1000 \\ 4.5 \text{ V} & 0 \text{ to } 500 \\ 6 \text{ V} & 0 \text{ to } 400 \end{cases}$	ns

DC SPECIFICATIONS

Symbol	Parameter	V_{CC}	Test Condition	$T_A = 25^\circ\text{C}$ 54HC and 74HC			- 40 to 85°C 74HC		- 55 to 125°C 54HC		Unit	
				Min.	Typ.	Max.	Min.	Max.	Min.	Max.		
V_{IH}	High Level Input Voltage	2.0		1.5	—	—	1.5	—	1.5	—	V	
		4.5		3.15	—	—	3.15	—	3.15	—		
		6.0		4.2	—	—	4.2	—	4.2	—		
V_{IL}	Low Level Input Voltage	2.0		—	—	0.5	—	0.5	—	0.5	V	
		4.5		—	—	1.35	—	1.35	—	1.35		
		6.0		—	—	1.8	—	1.8	—	1.8		
V_{OH}	High Level Output Voltage	2.0	V_I	I_O	1.9	2.0	—	1.9	—	1.9	—	V
		4.5	V_{IH} or V_{IL}	- 20 μA	4.4	4.5	—	4.4	—	4.4	—	
		6.0			5.9	6.0	—	5.9	—	5.9	—	
		4.5	- 4.0 mA - 5.2 mA	4.18	4.31	—	4.13	—	4.10	—		
6.0	5.68	5.8		—	5.63	—	5.60	—				
V_{OL}	Low Level Output Voltage	2.0	V_{IH} or V_{IL}	20 μA 4.0 mA 5.2 mA	—	0	0.1	—	0.1	—	0.1	V
		4.5			—	0	0.1	—	0.1	—	0.1	
		6.0			—	0	0.1	—	0.1	—	0.1	
		4.5			—	0.17	0.26	—	0.33	—	0.40	
6.0	—	0.18	0.26	—	0.33	—	0.40					
I_I	Input Leakage Current	6.0	$V_I = V_{CC}$ or GND	—	—	± 0.1	—	± 1		± 1	μA	
I_{CC}	Quiescent Supply Current	6.0	$V_I = V_{CC}$ or GND	—	—	4	—	40	80		μA	



AC ELECTRICAL CHARACTERISTICS ($V_{CC} = 5V$, $T_A = 25^\circ C$, $C_L = 15pt$, Input $t_r = t_f = 6ns$.)

Symbol	Parameter	54HC and 74HC			Unit
		MIN.	TYP.	MAX.	
t_{TLH} t_{THL}	Output Transition Time		4	8	ns
t_{PLH} t_{PHL}	Propagation Delay Time ($P_n, Q_n - \overline{P} = \overline{Q}$)		22	35	ns
t_{PLH} t_{PHL}	Propagation Delay Time ($\overline{G} - \overline{P} = \overline{Q}$)		12	20	ns

AC ELECTRICAL CHARACTERISTICS ($C_L = 50pF$, Input $t_r = t_f = 6ns$)

Symbol	Parameter	V_{CC}	Test Condition	$T_A = 25^\circ C$ 54HC and 74HC			-40 to 85°C 74HC		-55 to 125°C 54HC		Unit
				Min.	Typ.	Max.	Min.	Max.	Min.	Max.	
				t_{TLH} t_{THL}	Output Transition Time	2.0 4.5 6.0		— 30 —	75 15 13	— — —	
t_{PLH} t_{PHL}	Propagation Delay Time ($P_n, Q_n - \overline{P} = \overline{Q}$)	2.0 4.5 6.0		— 100 —	195 39 33	— — —	235 47 40			ns	
t_{PLH} t_{PHL}	Propagation Delay Time ($\overline{G} - \overline{P} = \overline{Q}$)	2.0 4.5 6.0		— 50 —	120 24 21	— — —	145 29 25			ns	
C_{IN}	Input Capacitance			—	5 10	—	10			pF	
$C_{PD} (*)$	Power Dissipation Capacitance				40					pF	

Note (*) C_{PD} is defined as the value the IC's of internal equivalent capacitance which is calculated from the operating current consumption without load.

Average operating current can be obtained by the following equation.

$$I_{CC(OPR)} = C_{PD} \cdot V_{CC} \cdot f_{IN} + I_{CC}$$