



MOTOROLA

1.1 GHz Super Low Power Dual Modulus Prescaler

The MC12052A is a super low power dual modulus prescaler used in phase-locked loop applications. Motorola's advanced Bipolar MOSAIC™ V technology is utilized to achieve low power dissipation of 2.7 mW at a minimum supply voltage of 2.7 V.

The MC12052A can be used with CMOS synthesizers requiring positive edges to trigger internal counters such as Motorola's MC145XXX series in a PLL to provide tuning signals up to 1.1 GHz in programmable frequency steps.

A Divide Ratio Control (SW) permits selection of a 64/65 or 128/129 divide ratio as desired.

The Modulus Control (MC) selects the proper divide number after SW has been biased to select the desired divide ratio.

- 1.1 GHz Toggle Frequency
- The MC12052 is Pin and Functionally Compatible with the MC12022
- Low Power 1.0 mA Typical
- 2.0 mA Maximum, -40 to 85°C, V_{CC} = 2.7 to 5.5 Vdc
- Short Setup Time (t_{set}) 16 ns Maximum @ 1.1 GHz
- Modulus Control Input Level is Compatible with Standard CMOS and TTL
- Maximum Input Voltage Should Be Limited to 6.5 Vdc

MOSAIC V is a trademark of Motorola

FUNCTIONAL TABLE

SW	MC	Divide Ratio
H	H	64
H	L	65
L	H	128
L	L	129

NOTES: 1. SW: H = V_{CC}, L = Open. A logic L can also be applied by grounding this pin, but this is not recommended due to increased power consumption.
 2. MC: H = 2.0 V to V_{CC}, L = GND to 0.8 V.

MAXIMUM RATINGS

Characteristic	Symbol	Range	Unit
Power Supply Voltage, Pin 2	V _{CC}	-0.5 to 7.0	Vdc
Operating Temperature Range	T _A	-40 to 85	°C
Storage Temperature Range	T _{stg}	-65 to 150	°C
Modulus Control Input, Pin 6	MC	-0.5 to 6.5	Vdc

MC12052A

MECL PLL COMPONENTS +64/65, +128/129 LOW POWER DUAL MODULUS PRESCALER

SEMICONDUCTOR TECHNICAL DATA



D SUFFIX
PLASTIC PACKAGE
CASE 751
(SO-8)



SD SUFFIX
PLASTIC PACKAGE
CASE 940
(SSOP-8)

PIN CONNECTIONS

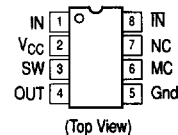

ORDERING INFORMATION

Device	Operating Temp Range	Package
MC12052AD	T _A =	SO-8
MC12052ASD	- 40° to +85°C	SSOP-8

MC12052A

ELECTRICAL CHARACTERISTICS ($V_{CC} = 2.7$ to 5.5 VDC, $T_A = -40$ to 85°C , unless otherwise noted.)

Characteristic	Symbol	Min	Typ	Max	Unit
Toggle Frequency (Sine Wave Input)	f_t	0.1	1.4	1.1	GHz
Supply Current (Pin 2)	I_{CC}	–	1.0	2.0	mA
Modulus Control Input High (MC)	V_{IH1}	2.0	–	$V_{CC} + 0.5$ V	V
Modulus Control Input Low (MC)	V_{IL1}	Gnd	–	0.8	V
Divide Ratio Control Input High (SW)	V_{IH2}	$V_{CC} - 0.5$ V	V_{CC}	$V_{CC} + 0.5$ V	VDC
Divide Ratio Control Input Low (SW)	V_{IL2}	Open	Open	Open	–
Output Voltage Swing (Note 2) ($C_L = 8.0$ pF, $R_L = 3.3$ k Ω)	V_{out}	0.8	1.1	–	V_{PP}
Modulus Setup Time MC to Out @ 1100 MHz	t_{set}	–	11	16	ns
Input Voltage Sensitivity 250–1100 MHz 100–250 MHz	V_{in}	100 400	– –	1000 1000	mV $_{PP}$
Output Current (Note 1) $V_{CC} = 2.7$ V, $C_L = 8.0$ pF, $R_L = 3.3$ k Ω $V_{CC} = 5.0$ V, $C_L = 8.0$ pF, $R_L = 7.2$ k Ω	I_O	– –	0.5 0.5	3.0 3.0	mA

NOTES: 1. Divide ratio of +64/65 @ 1.1 GHz
2. Valid over voltage range 2.7 to 5.5 V; $R_L = 3.3$ k Ω @ $V_{CC} = 2.7$ V; $R_L = 7.2$ k Ω @ $V_{CC} = 5.0$ V

Figure 1. Logic Diagram (MC12052A)

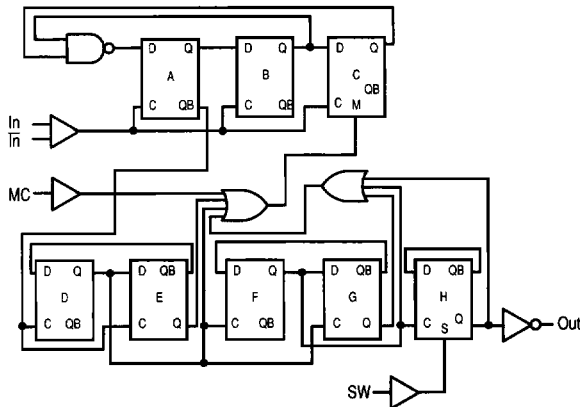
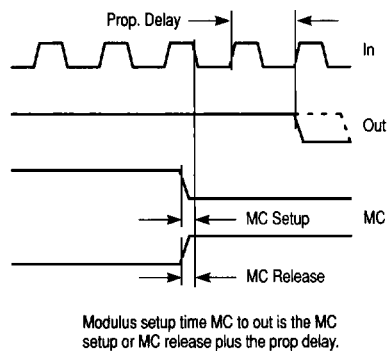
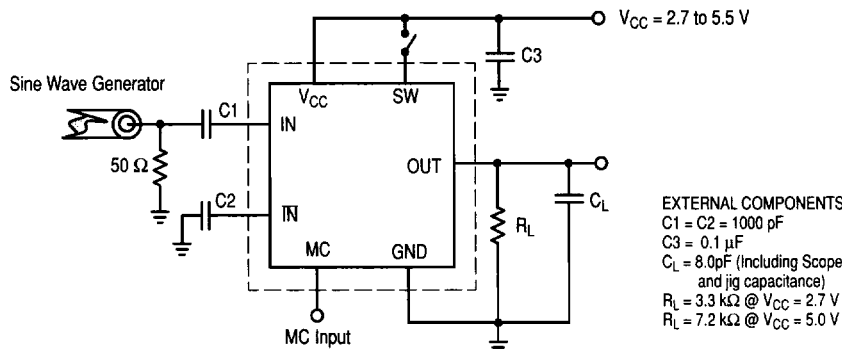

Figure 2. Modulus Setup Time



Modulus setup time MC to out is the MC setup or MC release plus the prop delay.

Figure 3. AC Test Circuit



EXTERNAL COMPONENTS
 $C_1 = C_2 = 1000$ pF
 $C_3 = 0.1$ μ F
 $C_L = 8.0$ pF (Including Scope and jig capacitance)
 $R_L = 3.3$ k Ω @ $V_{CC} = 2.7$ V
 $R_L = 7.2$ k Ω @ $V_{CC} = 5.0$ V

MC12052A

Figure 4. Typical Input Impedance versus Input Frequency

