

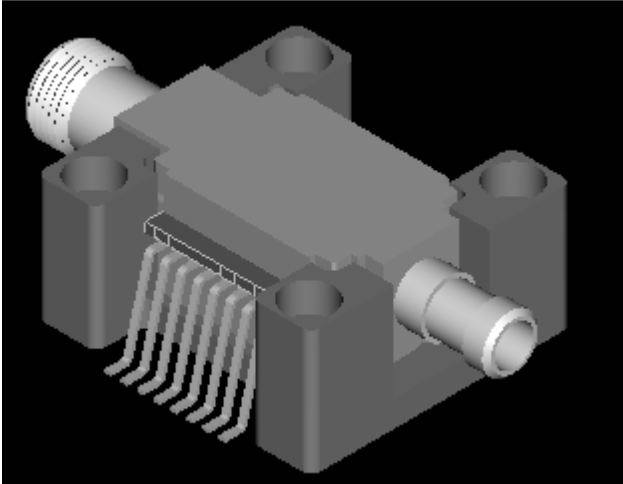

R768-Type OC-768/STM-256 Lightwave Receiver



The R768 Receiver is manufactured in a 16-pin, pigtailed surface-mount metal package with a single-ended V-connector.

Features

- High data rate capability, 40 Gbits/s
- PIN photodetector
- Fully operational through the L-band (1.6 μm) wavelength range
- Single-mode fiber pigtail with FC/PC optical connector
- Operating case temperature range: 0 °C to 65 °C
- Compact, butterfly package

Applications

- Line terminal equipment
- High-speed networks up to 40 Gbits/s
- SONET OC-768 and SDH STM-256 telecommunications applications
- Extended-reach datacom and telecom applications
- Digital video

Description

Receiver Operation

The R768 40 Gbits/s fiber-optic receiver consists of a high-speed photodetector (PIN) and a wide-band linear preamp in a pigtailed surface-mount metal package with a single-ended V-connector. It is designed for use in single-mode, high-speed telecommunication applications at the SONET OC-768 and the ITU-T SDH STM-256 data rate of 42.5 Gbits/s.

The operating case temperature range for the receiver is 0 °C to 65 °C.

The receiver is manufactured in a compact, 16-pin surface-mount package with a single-mode optical fiber pigtail. The fiber pigtail is internally beveled for low return loss and is available with an FC-PC optical connector.

The received data is dc-coupled.

The receiver requires only a 6 V power supply for operation, plus an optional VADJUST from –1.0 V to +1.0 V (see pin descriptions). The photodiode requires a separate bias voltage: for the PIN, a nominal reverse bias of 4 V is required.

Pin Information

Table 1. Pin Descriptions

Pin Number	Name
1	Not Used
2	GND
3	Alternate PIN Bias
4	GND
5	GND
6	GND
7	VADJUST (optional)
8	GND
9	GND
10	GND
11	GND
12	VCC
13	GND
14	PIN Bias
15	GND
16	NC

Absolute Maximum Ratings

Stresses in excess of the absolute maximum ratings can cause permanent damage to the device. These are absolute stress ratings only. Functional operation of the device is not implied at these or any other conditions in excess of those given in the operations section of the data sheet. Exposure to absolute maximum ratings for extended periods can adversely affect device reliability.

Parameter	Symbol	Min	Max	Unit
Positive Supply Voltage	VCC	5.0	7.0	V
Photodiode Forward Current*	IPD	—	1	mA
Maximum Reverse Bias	VB	—	5	V
Optical Input Power, PIN	P _{MAX}	—	8	dBm
Operating Case Temperature	T _C	0	65	°C
Storage Temperature	T _{stg}	-40	85	°C
Lead Soldering Temperature	—	—	250	°C
Lead Soldering Time	—	—	10	s

* Device is normally reverse biased. Forward biasing the photodiode can compromise device performance and reliability.

Optical Characteristics

Table 2. Optical Characteristics (T_A = 25 °C)

Parameter	Symbol	Min	Typ	Max	Unit
Optical wavelength for Rated Sensitivity	λ	1.480	—	1.610	μm
Sensitivity, PIN	P _{LOW}	—	-7	—	dBm
Maximum Optical Input Power, Average, PIN	P _{HIGH}	—	3	—	dBm
Optical Return Loss	—	-27	-30	—	dBm
Responsivity of PIN, $\lambda = 1.55 \mu\text{m}$	$\mathfrak{R}_{\text{PIN}}$	—	0.7	—	A/W
Total Dark Current	I _D	—	0.5	—	μA
Polarization-dependent Loss	PDL	—	—	0.5	dB

Electrical Characteristics

Table 3. Electrical Characteristics (T_A = 25 °C)

Parameter	Symbol	Min	Typ	Max	Unit
dc Power Supply Voltages:					
Positive Supply	V _{CC}	5.5	6.0	6.5	V
PIN Bias	V _{PIN}	3.5	4.0	4.5	V
Optional V _{ADJUST}	V _{ADJ}	-1.0	—	1.0	V
Positive dc Power Supply Current	I _{CC}	—	80	150	mA
Power Dissipation	P _{DISS}	—	—	0.975	W
Conversion Gain	—	—	60	—	V/W
Average Equivalent Input Noise Spectral Density	—	—	—	50	pA/√Hz
Low Frequency Cutoff (-3 dB)	f _L	—	100	—	kHz
Bandwidth	BW	—	45	—	GHz
Rolloff (3 dB + 5 GHz)	—	—	-10	—	dB
Peaking	—	—	—	2	dB
Deviation from Linear Phase:	—	—	—	—	—
100 kHz—25 GHz		—	10	—	deg
25 GHz—40 GHz		—	20	—	deg
40 GHz—50 GHz		—	40	—	deg
Output Return Loss:	S ₂₂	—	—	—	—
100 kHz—20 GHz		—	—	-15	dB
25 GHz—40 GHz		—	—	-10	dB
40 GHz—50 GHz		—	—	-5	dB

Outline Diagram

Dimensions are in millimeters.

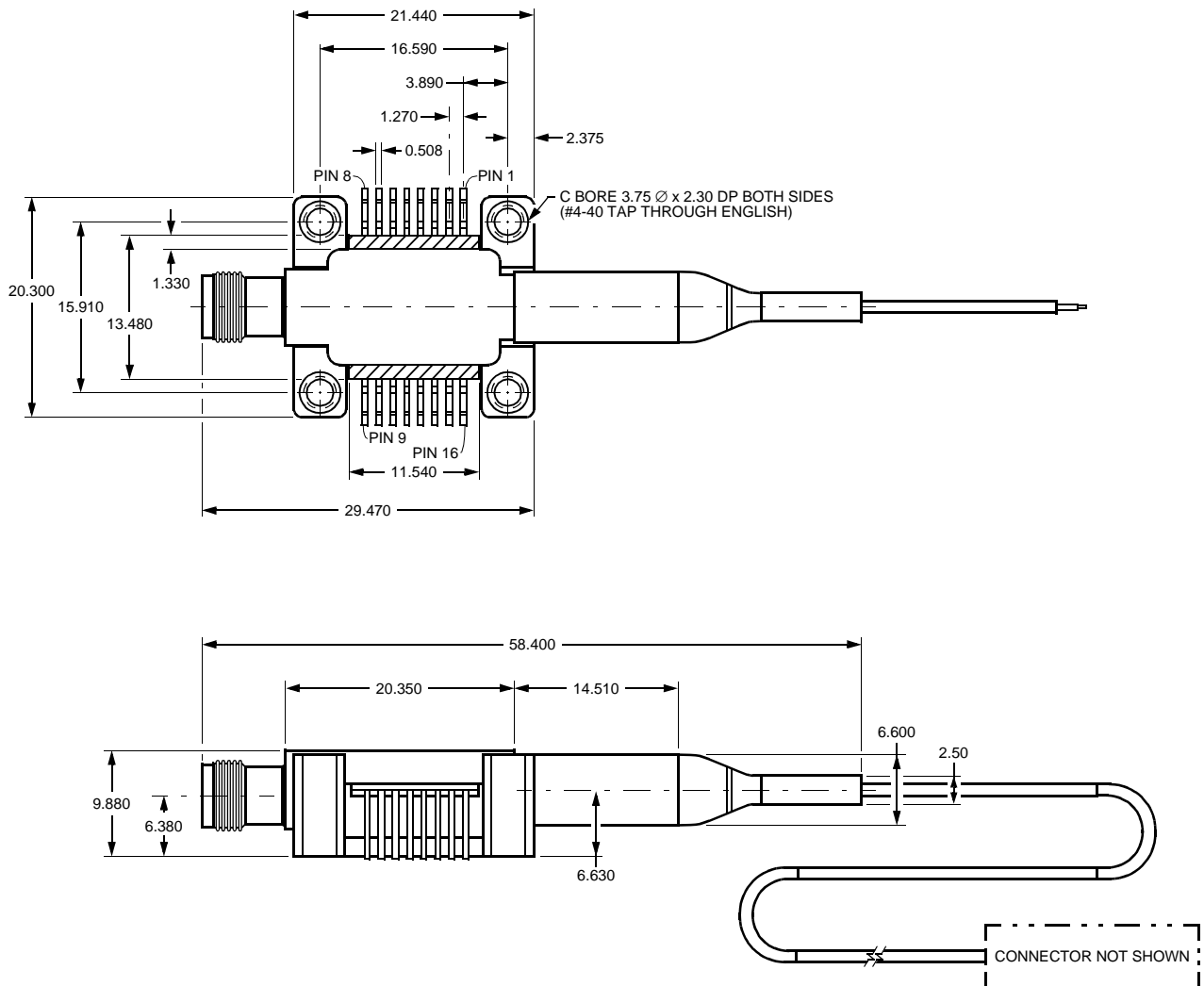

1-1157(F)

Ordering Information

Table 4. Ordering Information

Description	Product Code	Photodiode	Connector	Comcode
R768-Type OC-768/STM-256 Lightwave Receiver	R768PGAA	PIN	FC	108894635
	R768PSAA	PIN	LC	108894643
	R768PDAA	PIN	SC	108727041
	R768PJAA	PIN	Test Ferrule	TBD

For additional information, contact your Microelectronics Group Account Manager or the following:

INTERNET: <http://www.lucent.com/micro>, or for Optoelectronics information, <http://www.lucent.com/micro/opto>

E-MAIL: docmaster@micro.lucent.com

N. AMERICA: Microelectronics Group, Lucent Technologies Inc., 555 Union Boulevard, Room 30L-15P-BA, Allentown, PA 18109-3286
1-800-372-2447, FAX 610-712-4106 (In CANADA: **1-800-553-2448**, FAX 610-712-4106)

ASIA PACIFIC: Microelectronics Group, Lucent Technologies Singapore Pte. Ltd., 77 Science Park Drive, #03-18 Cintech III, Singapore 118256
Tel. (65) 778 8833, FAX (65) 777 7495

CHINA: Microelectronics Group, Lucent Technologies (China) Co., Ltd., A-F2, 23/F, Zao Fong Universe Building, 1800 Zhong Shan Xi Road, Shanghai 200233 P. R. China **Tel. (86) 21 6440 0468, ext. 325**, FAX (86) 21 6440 0652

JAPAN: Microelectronics Group, Lucent Technologies Japan Ltd., 7-18, Higashi-Gotanda 2-chome, Shinagawa-ku, Tokyo 141, Japan
Tel. (81) 3 5421 1600, FAX (81) 3 5421 1700

EUROPE: Data Requests: MICROELECTRONICS GROUP DATALINE: **Tel. (44) 7000 582 368**, FAX (44) 1189 328 148
Technical Inquiries: OPTOELECTRONICS MARKETING: **(44) 1344 865 900** (Ascot UK)

Lucent Technologies Inc. reserves the right to make changes to the product(s) or information contained herein without notice. No liability is assumed as a result of their use or application. No rights under any patent accompany the sale of any such product(s) or information.

