



CATV Amplifier Module

Features

- Specified for 77- and 110-Channel Loading
- Excellent Distortion Performance
- Silicon Bipolar Transistor Technology
- Unconditionally Stable Under All Load Conditions

Applications

- CATV Systems Operating in the 40 to 750 MHz Frequency Range
- Input Stage Amplifier in Optical Nodes, Line Extenders and Trunk Distribution Amplifiers for CATV Systems
- Driver Amplifier in Linear General Purpose Applications
- Output Stage Amplifier on Applications Requiring Low Power Dissipation

Description

- 24 Vdc Supply, 40 to 750 MHz, CATV Forward Amplifier Module
- Replaced MHW7222B. There are no form, fit or function changes with this part replacement.
- RoHS Compliant

MHW7222BN

**750 MHz
 22.7 dB GAIN
 110-CHANNEL
 CATV AMPLIFIER MODULE**

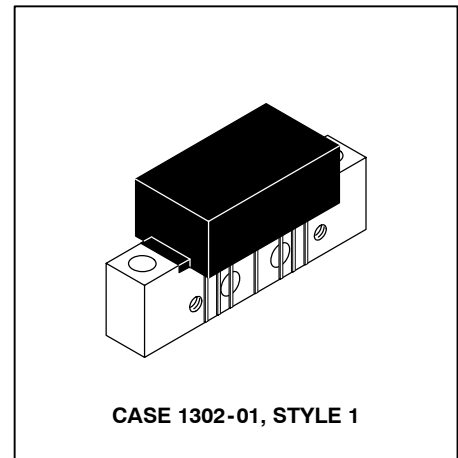

Table 1. Maximum Ratings

Rating	Symbol	Value	Unit
DC Supply Voltage	V_{CC}	+28	Vdc
RF Input Voltage (Single Tone)	V_{in}	+70	dBmV
Operating Case Temperature Range	T_C	-20 to +100	°C
Storage Temperature Range	T_{stg}	-40 to +100	°C

Table 2. Electrical Characteristics ($V_{CC} = 24$ Vdc, $T_C = +30^\circ\text{C}$, 75 Ω system unless otherwise noted)

Characteristic	Symbol	Min	Typ	Max	Unit
Frequency Range	BW	40	—	750	MHz
Power Gain $f = 50$ MHz $f = 750$ MHz	G_p	21.4 22.2	21.9 22.7	22.4 23.2	dB
Slope ($f = 40 - 750$ MHz)	S	0.2	0.7	1.2	—
Gain Flatness (Peak To Valley) $(f = 40 - 750$ MHz)	G_F	—	0.4	0.6	—
Input/Output Return Loss @ $f = 40$ MHz	IRL/ORL	20	25	—	dB
Derate Return Loss @ $f > 40$ MHz	RLD	—	—	0.006	dB/MHz
Composite Second Order $(V_{out} = +40$ dBmV/ch; 110 Channels) $(V_{out} = +44$ dBmV/ch; 77 Channels)	CSO_{110} CSO_{77}	— —	-67 -67	-60 -60	dBc

Table 2. Electrical Characteristics ($V_{CC} = 24$ Vdc, $T_C = +30^\circ\text{C}$, $75\ \Omega$ system unless otherwise noted) **(continued)**

Characteristic	Symbol	Min	Typ	Max	Unit
Cross Modulation Distortion ($V_{out} = +40$ dBmV/ch, 110-Channel @ $F_m = 55.25$ MHz) ($V_{out} = +44$ dBmV/ch, 77-Channel @ $F_m = 55.25$ MHz)	XMD ₁₁₀ XMD ₇₇	— —	- 63 - 59	- 60 - 56	dBc
Composite Triple Beat ($V_{out} = +40$ dBmV/ch, 110-Channels, Worst Case) ($V_{out} = +44$ dBmV/ch, 77-Channels, Worst Case)	CTB ₁₁₀ CTB ₇₇	— —	- 64 - 65	- 61 - 62	dBc
Noise Figure f = 50 MHz f = 750 MHz	NF	— —	3.7 5	4.5 6.5	dB
DC Current	I_{DC}	180	220	240	mA

PACKAGE DIMENSIONS

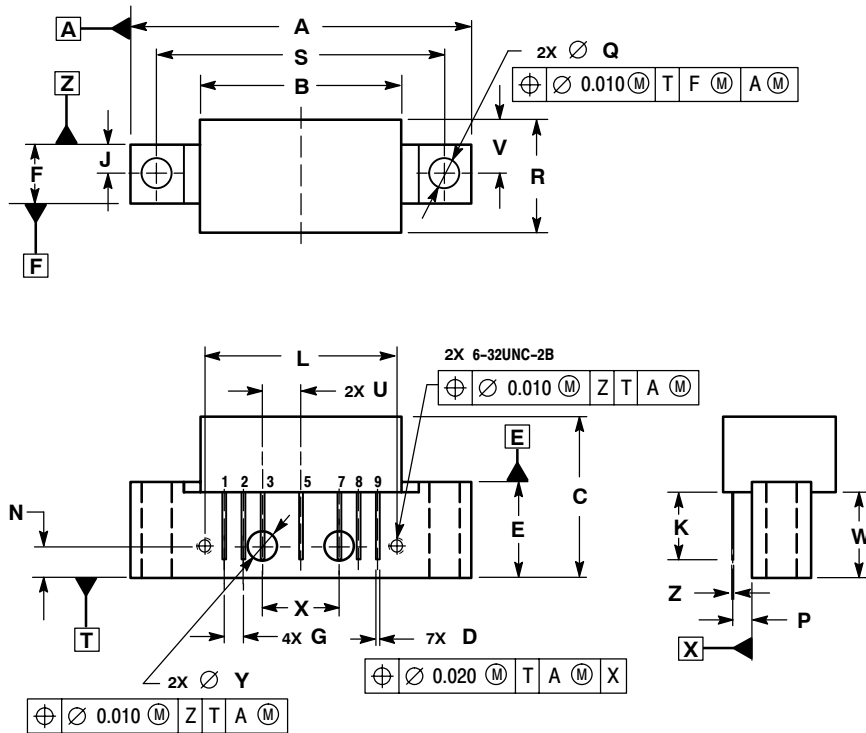

- NOTES:
 1. DIMENSIONS ARE IN INCHES.
 2. INTERPRET DIMENSIONS AND TOLERANCES PER ASME Y14.5M, 1994.

DIM	INCHES		MILLIMETERS	
	MIN	MAX	MIN	MAX
A	---	1.775	---	45.085
B	---	1.085	---	27.559
C	---	0.840	---	21.336
D	0.015	0.021	0.381	0.533
E	0.465	0.510	11.811	12.954
F	0.300	0.325	7.62	8.255
G	0.100 BSC		2.540 BSC	
J	0.156 BSC		3.962 BSC	
K	0.315	0.355	8.001	9.017
L	1.000 BSC		25.400 BSC	
N	0.165 BSC		4.191 BSC	
P	0.100 BSC		2.540 BSC	
Q	0.148	0.168	3.759	4.267
R	---	0.600	---	15.24
S	1.500 BSC		38.100 BSC	
U	0.200 BSC		5.080 BSC	
V	---	0.250	---	6.350
W	0.435	---	11.049	---
X	0.400 BSC		10.160 BSC	
Y	0.152	0.163	3.861	4.140
Z	0.009	0.011	0.229	0.279

- STYLE 1:
 PIN 1: RF INPUT
 2: GROUND
 3: GROUND
 4: DELETED
 5: VDC
 6: DELETED
 7: GROUND
 8: GROUND
 9: RF OUTPUT

CASE 1302-01
 ISSUE E

MHW7222BN

How to Reach Us:

Home Page:

www.freescale.com

E-mail:

support@freescale.com

USA/Europe or Locations Not Listed:

Freescale Semiconductor
Technical Information Center, CH370
1300 N. Alma School Road
Chandler, Arizona 85224
+1-800-521-6274 or +1-480-768-2130
support@freescale.com

Europe, Middle East, and Africa:

Freescale Halbleiter Deutschland GmbH
Technical Information Center
Schatzbogen 7
81829 Muenchen, Germany
+44 1296 380 456 (English)
+46 8 52200080 (English)
+49 89 92103 559 (German)
+33 1 69 35 48 48 (French)
support@freescale.com

Japan:

Freescale Semiconductor Japan Ltd.
Headquarters
ARCO Tower 15F
1-8-1, Shimo-Meguro, Meguro-ku,
Tokyo 153-0064
Japan
0120 191014 or +81 3 5437 9125
support.japan@freescale.com

Asia/Pacific:

Freescale Semiconductor Hong Kong Ltd.
Technical Information Center
2 Dai King Street
Tai Po Industrial Estate
Tai Po, N.T., Hong Kong
+800 2666 8080
support.asia@freescale.com

For Literature Requests Only:

Freescale Semiconductor Literature Distribution Center
P.O. Box 5405
Denver, Colorado 80217
1-800-441-2447 or 303-675-2140
Fax: 303-675-2150
LDCForFreescaleSemiconductor@hibbertgroup.com

Information in this document is provided solely to enable system and software implementers to use Freescale Semiconductor products. There are no express or implied copyright licenses granted hereunder to design or fabricate any integrated circuits or integrated circuits based on the information in this document.

Freescale Semiconductor reserves the right to make changes without further notice to any products herein. Freescale Semiconductor makes no warranty, representation or guarantee regarding the suitability of its products for any particular purpose, nor does Freescale Semiconductor assume any liability arising out of the application or use of any product or circuit, and specifically disclaims any and all liability, including without limitation consequential or incidental damages. "Typical" parameters that may be provided in Freescale Semiconductor data sheets and/or specifications can and do vary in different applications and actual performance may vary over time. All operating parameters, including "Typicals", must be validated for each customer application by customer's technical experts. Freescale Semiconductor does not convey any license under its patent rights nor the rights of others. Freescale Semiconductor products are not designed, intended, or authorized for use as components in systems intended for surgical implant into the body, or other applications intended to support or sustain life, or for any other application in which the failure of the Freescale Semiconductor product could create a situation where personal injury or death may occur. Should Buyer purchase or use Freescale Semiconductor products for any such unintended or unauthorized application, Buyer shall indemnify and hold Freescale Semiconductor and its officers, employees, subsidiaries, affiliates, and distributors harmless against all claims, costs, damages, and expenses, and reasonable attorney fees arising out of, directly or indirectly, any claim of personal injury or death associated with such unintended or unauthorized use, even if such claim alleges that Freescale Semiconductor was negligent regarding the design or manufacture of the part.

Freescale™ and the Freescale logo are trademarks of Freescale Semiconductor, Inc. All other product or service names are the property of their respective owners.
© Freescale Semiconductor, Inc. 2006. All rights reserved.

RoHS-compliant and/or Pb-free versions of Freescale products have the functionality and electrical characteristics of their non-RoHS-compliant and/or non-Pb-free counterparts. For further information, see <http://www.freescale.com> or contact your Freescale sales representative.

For information on Freescale's Environmental Products program, go to <http://www.freescale.com/ep>.

