

DYNAMIC RAM MODULE

MT8257M 256K x 8 BIT DYNAMIC RAM
 MT9257M 256K x 9 BIT DYNAMIC RAM

MICRON
 TECHNOLOGY, INC.

2805 East Columbia Road
 Boise, Idaho 83706
 TEL. (208) 386-3900
 TWX 910-970-5973



We're building our reputation on innovation.

FEATURES

- Industry standard pin out in a 30-pin single-in-line memory module (SIMM)
- Single 5V±10% power supply
- All inputs, outputs and clocks are fully TTL compatible
- Low power, 135mW standby, 1350mW active, typical
- On-board power supply decoupling capacitors (0.2µf) for low noise
- Slow edge rates allowed on all inputs
- Refresh modes: $\overline{\text{RAS}}$ only, and hidden
- 256 cycle refresh distributed across 4 ms (every 16 µsec)
- Page Mode cycle

OPTIONS

• Timing

- 100 ns access
- 120 ns access
- 150 ns access
- 200 ns access

• Organization

- 256K x 8
- 256K x 9

• Package: Leadless 30-pin SIMM

• Order example: 256K x 8, 150 ns access, Leadless SIMM = MT8257M - 15

MARKING

- 10
- 12
- 15
- 20

MT8257
 MT9257

M

ORIG

MCT

002970

136

2970

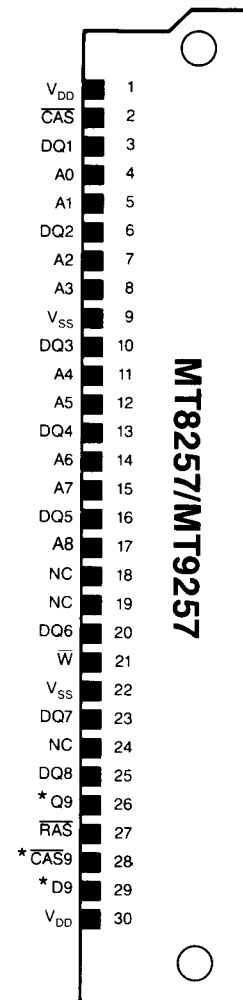

*MT9257 only
 NC on MT8257

A0 - A8	Address Inputs
CAS, CAS9	Column Address Strobe
DQ1 - DQ8	Data-In/Data-Out
D9	Data In
Q9	Data Out
RAS	Row Address Strobe
W	Write Enable
V _{DD}	Power (+5V)
V _{SS}	Ground

GENERAL DESCRIPTION

The MT8257/MT9257 is a randomly accessed solid-state memory module organized in a 262,144 word x 8 or x 9 configuration. The 18 address bits are entered 9 bits at a time using $\overline{\text{RAS}}$ to latch the first 9 bits and $\overline{\text{CAS}}$ the latter 9 bits. The ninth bit D9, Q9 on the MT9257, is generally used for parity and is controlled by $\overline{\text{CAS}}$ 9.

The MT8257/MT9257 is a 30-pin single-in-line memory module comprised of nine MT1257 DRAMs in 18-pin plastic leaded chip carriers together with nine 0.2µf decoupling capacitors. Each MT1257 is described in its data sheet and is manufactured, fully tested and quality controlled in Micron's modern Boise, Idaho USA facility. Each unit receives accelerated burn-in and several hours of AMBYX™ system level test prior to assembly onto the SIMM package. After assembly a further set of electrical tests is performed.

Please contact the factory for technical, test, and application assistance. Micron can also furnish the representative and distributor nearest you. The success of our business depends on the success of your application.

ELECTRICAL SPECIFICATION

Refer to the MT1257 data sheet for all electrical specifications. Combining these devices in a SIMM configuration slightly increases load capacitance. The common input/output feature requires the use of an early write cycle to prevent data contention on DQ lines. The MT8257/MT9257 is rated for operation from 0°C to 70°C.

FUNCTIONAL BLOCK DIAGRAM

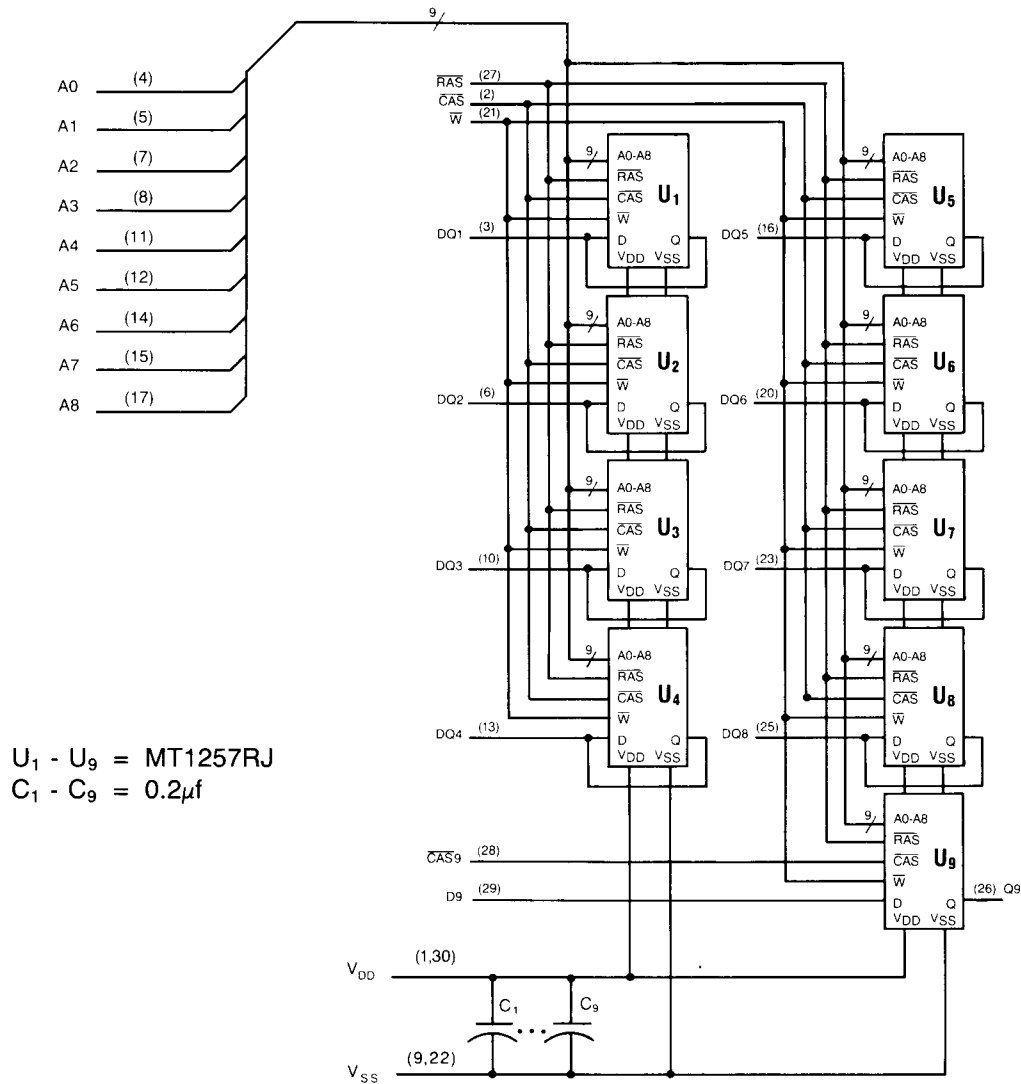

MECHANICAL DATA

