



SANYO Semiconductors

DATA SHEET

LA7218M — Monolithic Linear IC

Sync Separator IC with AFC and Sync Detection Functions

Overview

The LA7218M is a sync separator IC with AFC designed for use in video cameras, VCRs, TVs, and similar products. It also provides a sync detection function. This IC can implement an adjustment-free system with high detection precision using a ceramic oscillator VCO and a PLL-based horizontal sync detection circuit.

Functions

- Sync separator
- Vertical sync separator
- Horizontal AFC
- VCO (32f_H)
- Sync detector

* : Since the pin functions are fixed, this ICs performance cannot be adjusted with external signals. Furthermore, since this IC includes no EPROM or other memory, its software cannot be rewritten.

Features

- Ceramic oscillator adopted for adjustment-free manufacturing
- Negative outputs
- High-impedance video signal inputs
- Supply voltage : 5V

Specifications

Maximum Ratings at Ta = 25°C

Parameter	Symbol	Conditions	Ratings	Unit
Maximum supply voltage	V _{CC max}		7	V
Allowable power dissipation	P _{d max}	Ta ≤ 65°C	150	mW
Operating temperature	T _{opr}		-15 to +65	°C
Storage temperature	T _{stg}		-40 to +125	°C

■ All and all SANYO Semiconductor products described or contained herein do not have specifications that can handle applications that require extremely high levels of reliability, such as life-support systems, aircraft's control systems, or other applications whose failure can be reasonably expected to result in serious physical and/or material damage. Consult with your SANYO Semiconductor representative nearest you before using any SANYO Semiconductor products described or contained herein in such applications.

■ SANYO Semiconductor assumes no responsibility for equipment failures that result from using products at values that exceed, even momentarily, rated values (such as maximum ratings, operating condition ranges, or other parameters) listed in products specifications of any and all SANYO Semiconductor products described or contained herein.

SANYO Semiconductor Co., Ltd.

TOKYO OFFICE Tokyo Bldg., 1-10, 1 Chome, Ueno, Taito-ku, TOKYO, 110-8534 JAPAN

LA7218M

Operating Conditions at Ta = 25°C

Parameter	Symbol	Conditions	Ratings	Unit
Recommended supply voltage	V _{CC}		5.0	V
Operating supply voltage range	V _{CC op}		4.5 to 5.5	V

Electrical Characteristics at Ta = 25°C, V_{CC} = 5V

Parameter	Symbol	Conditions	Ratings			Unit
			min	typ	max	
Current drain	I _{CC}	Standard color bar input	4.9	7	9.1	mA
Sync separator minimum input level	V _{I min}		-15	-11	-8	dB
HD output delay time	T _{HD}	Compare pins 2 and 9	0	0.4	0.8	μs
HD output pulse width	T _{HW}		3.5	4.9	5.3	μs
VD output delay time	T _{VD}	Compare pins 2 and 5	9	13	17	μs
VD output pulse width	T _{VW}		0.16	0.21	0.26	ms
Free-running frequency	FO	With switch SW1 off	15.4	15.75	16.1	kHz
Capture range 1	F _{CH}	Discriminated by comparing pins 2 and 9	300	500		Hz
Capture range 2	F _{CL}	Discriminated by comparing pins 2 and 9	1000	1500		Hz
SYNC output high level	V _{SH}	Read from the pin 4 waveform	3.9	4.2		V
SYNC output low level	V _{SL}	Read from the pin 4 waveform		0.8	1.0	V
HD output high level	V _{HH}	Read from the pin 9 waveform	3.9	4.2		V
HD output low level	V _{HL}	Read from the pin 9 waveform		0.8	1.0	V
VD output high level	V _{VH}	Read from the pin 5 waveform	3.9	4.2		V
VD output low level	V _{VL}	Read from the pin 5 waveform		0.8	1.0	V
DET output high level	V _{DH}		4.8	5.0		V
DET output low level	V _{DL}	SW1 off		0.1	0.3	V
Comparator threshold high level	V _{TH}	SW2-a	2.7	2.95	3.2	V
Comparator threshold low level	V _{TL}	SW2-a	2.4	2.7	3.0	V
Threshold width	V _{TW}	V _{TH} -V _{TL}	0.10	0.22	0.40	V
DET operating current (high)	I _{DH}	SW2-b	40	65	90	μA
DET operating current (low)	I _{DL}	SW2-b	40	65	90	μA

Package Dimensions

unit : mm (typ)

3034B

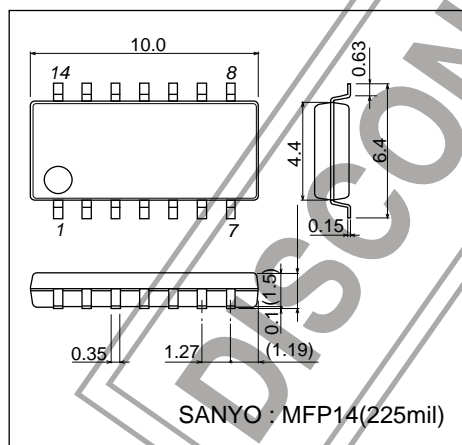

LA7218M

Equivalent Circuit Block Diagram

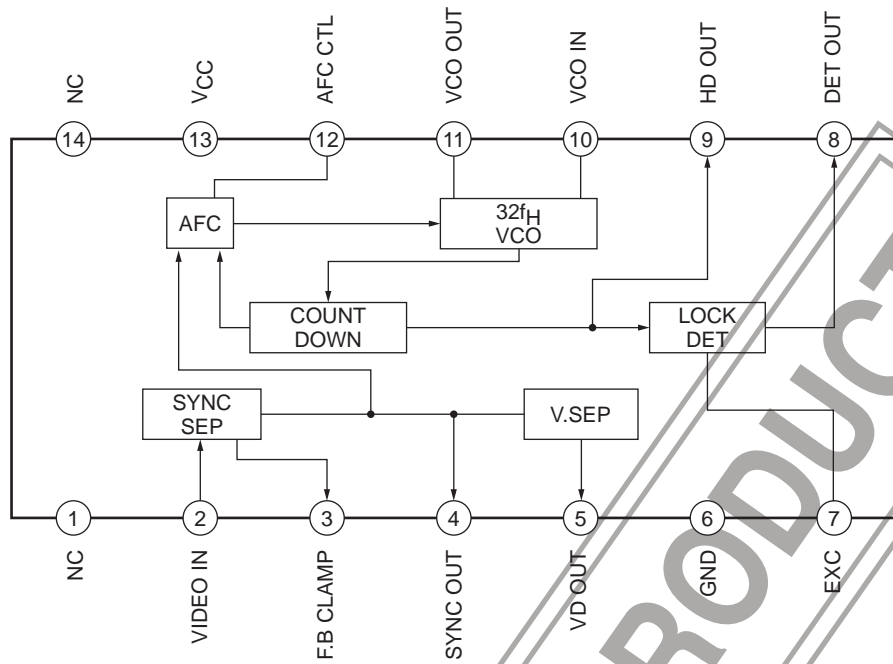

Test Circuit Diagram

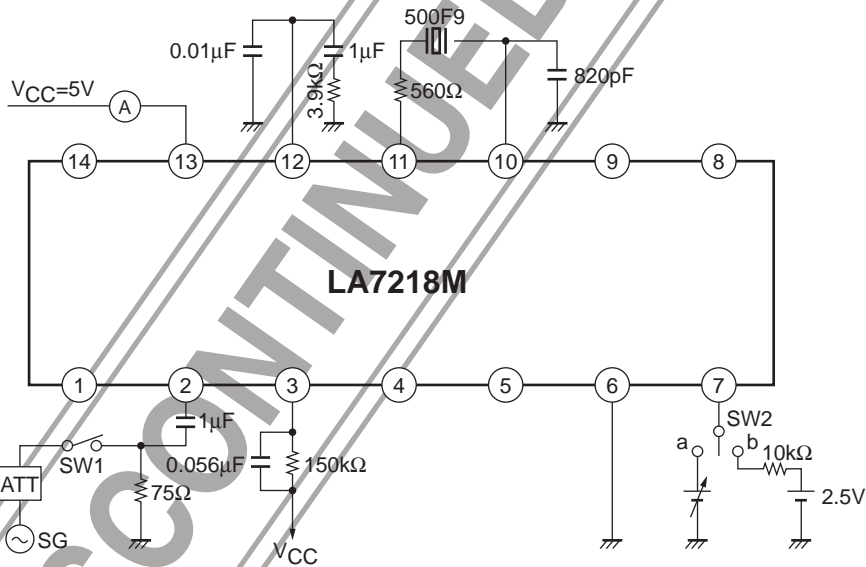

LA7218M

- Set switch SW1 off only for f_0 and V_{DL} measurement. Set it on for all other measurements.
- Switch SW2 has a neutral position, and is set to the "a" position for the V_{TH} and V_{TL} measurements, to the "b" position for the I_{DH} and I_{DL} measurements, and to neutral for all other measurements.
- Use a 1Vp-p standard color bar signal for the SG signal, use an attenuator for the V_I min measurement, and use the waveform shown below for the f_{CH} and f_{CL} measurements.

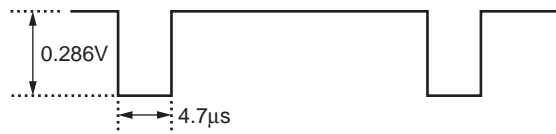

- A square wave, such as that shown above, is used for the I_{DH} and I_{DL} measurement. Its frequency is 31.5kHz.
- The f_{CH} (and f_{CL}) measurement is performed by setting the SG signal frequency high (or low) so that lock is lost and lowering (raising) the frequency from those points and measuring the two frequencies at which the circuit locks. The difference between these frequencies and f_0 is f_{CH} (and f_{CL}).
- The V_{TH} (and V_{TL}) measurement is performed by setting the pin 7 applied voltage V_1 to 0V (or 5V) and raising (or lowering) the voltage from those points and measuring the V_1 voltages at the points pin 8 switches (inverts) from low (high) to high (low). Those voltages are V_{TH} and V_{TL} , respectively.
- I_{DH} and I_{DL} are calculated from the pin 7 waveform as shown in the figure below.

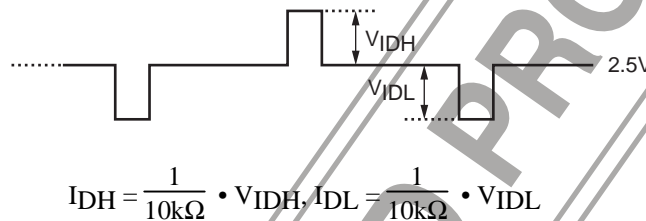

$$I_{DH} = \frac{1}{10k\Omega} \cdot V_{IDH}, I_{DL} = \frac{1}{10k\Omega} \cdot V_{IDL}$$

- Specifications of any and all SANYO Semiconductor products described or contained herein stipulate the performance, characteristics, and functions of the described products in the independent state, and are not guarantees of the performance, characteristics, and functions of the described products as mounted in the customer's products or equipment. To verify symptoms and states that cannot be evaluated in an independent device, the customer should always evaluate and test devices mounted in the customer's products or equipment.
- SANYO Semiconductor Co., Ltd. strives to supply high-quality high-reliability products. However, any and all semiconductor products fail with some probability. It is possible that these probabilistic failures could give rise to accidents or events that could endanger human lives, that could give rise to smoke or fire, or that could cause damage to other property. When designing equipment, adopt safety measures so that these kinds of accidents or events cannot occur. Such measures include but are not limited to protective circuits and error prevention circuits for safe design, redundant design, and structural design.
- In the event that any or all SANYO Semiconductor products (including technical data, services) described or contained herein are controlled under any of applicable local export control laws and regulations, such products must not be exported without obtaining the export license from the authorities concerned in accordance with the above law.
- No part of this publication may be reproduced or transmitted in any form or by any means, electronic or mechanical, including photocopying and recording, or any information storage or retrieval system, or otherwise, without the prior written permission of SANYO Semiconductor Co., Ltd.
- Any and all information described or contained herein are subject to change without notice due to product/technology improvement, etc. When designing equipment, refer to the "Delivery Specification" for the SANYO Semiconductor product that you intend to use.
- Information (including circuit diagrams and circuit parameters) herein is for example only; it is not guaranteed for volume production. SANYO Semiconductor believes information herein is accurate and reliable, but no guarantees are made or implied regarding its use or any infringements of intellectual property rights or other rights of third parties.

This catalog provides information as of November, 2006. Specifications and information herein are subject to change without notice.