

Document	853-1401
ECN No.	97959
Date of Issue	October 25, 1989
Status	Product Specification
RF Communications	

NE/SA605

High performance low power mixer FM IF system

DESCRIPTION

The NE/SA605 is a high performance monolithic low-power FM IF system incorporating a mixer/oscillator, two limiting intermediate frequency amplifiers, quadrature detector, muting, logarithmic received signal strength indicator (RSSI), and voltage regulator. The NE/SA605 combines the functions of Signetics' NE602 and NE604A, but features a higher mixer input intercept point, higher IF bandwidth (25MHz) and temperature compensated RSSI and limiters permitting higher performance application. The NE/SA605 is available in 20-lead dual-in-line plastic and 20-lead SOL (surface-mounted miniature package).

The NE/SA605 and NE/SA615 are functionally the same device types. The difference between the two devices lies in the guaranteed specifications. The NE/SA615 has a higher I_{CC} , lower input third order intercept point, lower conversion mixer gain, lower limiter gain, lower AM rejection, lower SINAD, higher THD, and higher RSSI error than the NE/SA605. Both the NE/SA605 and NE/SA615 devices will meet the EIA specifications for AMPS and TACS cellular radio applications.

FEATURES

- Low power consumption: 5.7mA typical at 6V
- Mixer input to >500MHz
- Mixer conversion power gain of 13dB at 45MHz
- Mixer noise figure of 4.6dB at 45MHz
- XTAL oscillator effective to 150MHz (L.C. oscillator to 1GHz local oscillator can be injected)
- 102dB of IF Amp/Limiter gain
- 25MHz limiter small signal bandwidth
- Temperature compensated logarithmic Received Signal Strength Indicator (RSSI) with a dynamic range in excess of 90dB
- Two audio outputs – muted and unmuted
- Low external component count; suitable for crystal/ceramic/LC filters
- Excellent sensitivity: 0.22 μ V into 50 Ω matching network for 12dB SINAD (Signal to Noise and Distortion ratio) for 1kHz tone with RF at 45MHz and IF at 455kHz
- SA605 meets cellular radio specifications
- ESD hardened

PIN CONFIGURATION

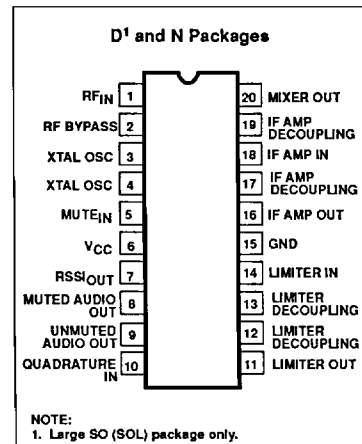

APPLICATIONS

- Cellular radio FM IF
- High performance communications receivers
- Single conversion VHF/UHF receivers
- SCA receivers
- RF level meter
- Spectrum analyzer
- Instrumentation
- FSK and ASK data receivers
- Log amps
- Wideband low current amplification

ORDERING INFORMATION

DESCRIPTION	TEMPERATURE RANGE	ORDER CODE
20-Pin Plastic DIP	0 to +70°C	NE605N
20-Pin Plastic SOL (Surface-mount)	0 to +70°C	NE605D
20-Pin Plastic DIP	-40 to +85°C	SA605N
20-Pin Plastic SOL (Surface-mount)	-40 to +85°C	SA605D

High performance low power mixer FM IF system

NE/SA605

BLOCK DIAGRAM

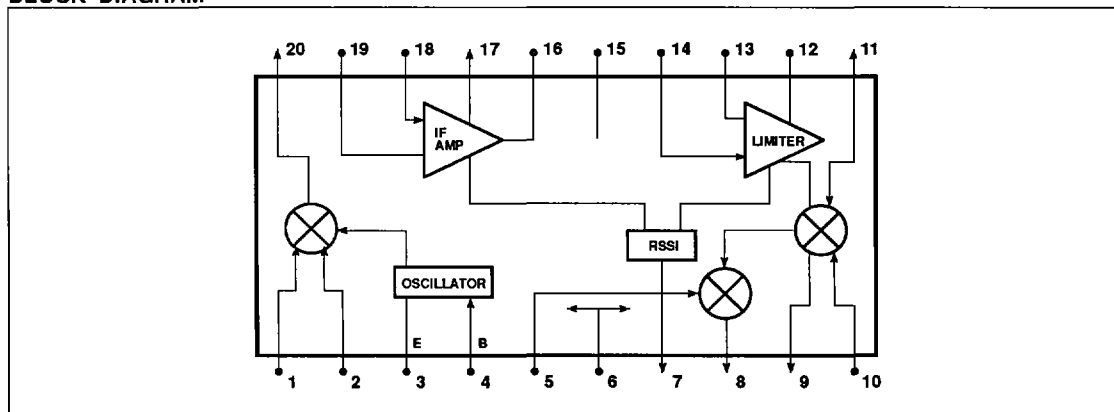

High performance low power mixer FM IF system

NE/SA605

ABSOLUTE MAXIMUM RATINGS

SYMBOL	PARAMETER	RATING	UNITS
V _{CC}	Single supply voltage	9	V
T _{STG}	Storage temperature range	-65 to +150	°C
T _A	Operating ambient temperature range NE605	0 to +70	°C
	SA605	-40 to +85	°C
θ _{JA}	Thermal impedance D package	90	°C/W
	N package	75	°C/W

DC ELECTRICAL CHARACTERISTICS V_{CC} = +6V, T_A = 25°C; unless otherwise stated.

SYMBOL	PARAMETER	TEST CONDITIONS	LIMITS						UNITS
			NE605			SA605			
			MIN	TYP	MAX	MIN	TYP	MAX	
V _{CC}	Power supply voltage range		4.5		8.0	4.5		8.0	V
I _{CC}	DC current drain		5.1	5.7	6.5	4.55	5.7	6.55	mA
	Mute switch input threshold (ON)		1.7			1.7			V
	(OFF)				1.0			1.0	V

AC ELECTRICAL CHARACTERISTICS

Typical reading at T_A = 25°C; V_{CC} = +6V, unless otherwise stated. RF frequency = 45MHz + 14.5dBV RF input step-up; IF frequency = 455kHz; R₁₇ = 5.1k; RF level = -45dBm; FM modulation = 1kHz with ±8kHz peak deviation. Audio output with C-message weighted filter and de-emphasis capacitor. Test circuit Figure 1. The parameters listed below are tested using automatic test equipment to assure consistent electrical characteristics. The limits do not represent the ultimate performance limits of the device. Use of an optimized RF layout will improve many of the listed parameters.

SYMBOL	PARAMETER	TEST CONDITIONS	LIMITS						UNITS
			NE605			SA605			
			MIN	TYP	MAX	MIN	TYP	MAX	
Mixer/Osc section (ext LO = 300mV)									
f _{IN}	Input signal frequency			500			500		MHz
f _{OSC}	Crystal oscillator frequency			150			150		MHz
	Noise figure at 45MHz			5.0			5.0		dB
	Third-order input intercept point	f ₁ = 45.0; f ₂ = 45.06MHz		-10			-10		dBm
	Conversion power gain	Matched 14.5dBV step-up	10.5	13	14.5	10	13	15	dB
		50Ω source		-1.7			-1.7		dB
	RF input resistance	Single-ended input	3.5	4.7		3.0	4.7		kΩ
	RF input capacitance			3.5	4.0		3.5	4.0	pF
	Mixer output resistance	(Pin 20)	1.3	1.5		1.25	1.5		kΩ
IF section									
	IF amp gain	50Ω source		39.7			39.7		dB
	Limiter gain	50Ω source		62.5			62.5		dB
	Input limiting -3dB, R ₁₇ = 5.1k	Test at Pin 18		-113			-113		dBm
	AM rejection	80% AM 1kHz	30	34	42	29	34	43	dB
	Audio level, R ₁₀ = 100k	15nF de-emphasis	110	150	250	80	150	260	mV _{RMS}

High performance low power mixer FM IF system

NE/SA605

SYMBOL	PARAMETER	TEST CONDITIONS	LIMITS						UNITS
			NE605			SA605			
			MIN	TYP	MAX	MIN	TYP	MAX	
	Unmuted audio level, $R_{11} = 100k$	150pF de-emphasis		480			480		mV
	SINAD sensitivity	RF level -118dB		16			16		dB
THD	Total harmonic distortion		-35	-42		-34	-42		dB
S/N	Signal-to-noise ratio	No modulation for noise		73			73		dB
	IF RSSI output, $R_9 = 100k\Omega^1$	IF level = -118dBm	0	160	550	0	160	650	mV
		IF level = -68dBm	2.0	2.5	3.0	1.9	2.5	3.1	V
		IF level = -18dBm	4.1	4.8	5.5	4.0	4.8	5.6	V
	RSSI range	$R_9 = 100k\Omega$ Pin 16		90			90		dB
	RSSI accuracy	$R_9 = 100k\Omega$ Pin 16		± 1.5			± 1.5		dB
	IF input impedance		1.40	1.6		1.40	1.6		k Ω
	IF output impedance		0.85	1.0		0.85	1.0		k Ω
	Limiter input impedance		1.40	1.6		1.40	1.6		k Ω
	Unmuted audio output resistance			58			58		k Ω
	Muted audio output resistance			58			58		k Ω
RF/IF section (int LO)									
	Unmuted audio level	4.5V = V_{CC} , RF level = -27dBm		450			450		mV _{RMS}
	System RSSI output	4.5V = V_{CC} , RF level = -27dBm		4.3			4.3		V

NOTE:

- The generator source impedance is 50 Ω , but the NE/SA605 input impedance at Pin 18 is 1500 Ω . As a result, IF level refers to the actual signal that enters the NE/SA605 input (Pin 8) which is about 21dB less than the "available power" at the generator.

CIRCUIT DESCRIPTION

The NE/SA605 is an IF signal processing system suitable for second IF or single conversion systems with input frequency as high as 1GHz. The bandwidth of the IF amplifier is about 40MHz, with 39.7dB(v) of gain from a 50 Ω source. The bandwidth of the limiter is about 28MHz with about 62.5dB(v) of gain from a 50 Ω source. However, the gain/bandwidth distribution is optimized for 455kHz, 1.5k Ω source applications. The overall system is well-suited to battery operation as well as high performance and high quality products of all types.

The input stage is a Gilbert cell mixer with oscillator. Typical mixer characteristics include a noise figure of 5dB, conversion gain of 13dB, and input third-order intercept of -10dBm. The oscillator will operate in excess of 1GHz in L/C tank configurations. Hartley or Colpitts circuits can be used up to 100MHz for xtal configurations. Butler

oscillators are recommended for xtal configurations up to 150MHz.

The output of the mixer is internally loaded with a 1.5k Ω resistor permitting direct connection to a 455kHz ceramic filter. The input resistance of the limiting IF amplifiers is also 1.5k Ω . With most 455kHz ceramic filters and many crystal filters, no impedance matching network is necessary. To achieve optimum linearity of the log signal strength indicator, there must be a 12dB(v) insertion loss between the first and second IF stages. If the IF filter or interstage network does not cause 12dB(v) insertion loss, a fixed or variable resistor can be added between the first IF output (Pin 16) and the interstage network.

The signal from the second limiting amplifier goes to a Gilbert cell quadrature detector. One port of the Gilbert cell is internally driven by the IF. The other output of the IF is AC-coupled to a tuned quadrature network. This

signal, which now has a 90 $^\circ$ phase relationship to the internal signal, drives the other port of the multiplier cell.

Overall, the IF section has a gain of 90dB. For operation at intermediate frequencies greater than 455kHz, special care must be given to layout, termination, and interstage loss to avoid instability.

The demodulated output of the quadrature detector is available at two pins, one continuous and one with a mute switch. Signal attenuation with the mute activated is greater than 60dB. The mute input is very high impedance and is compatible with CMOS or TTL levels.

A log signal strength completes the circuitry. The output range is greater than 90dB and is temperature compensated. This log signal strength indicator exceeds the criteria for AMPs or TACs cellular telephone.

NOTE: dB(v) = 20log V_{OUT}/V_{IN}

High performance low power mixer FM IF system

NE/SA605

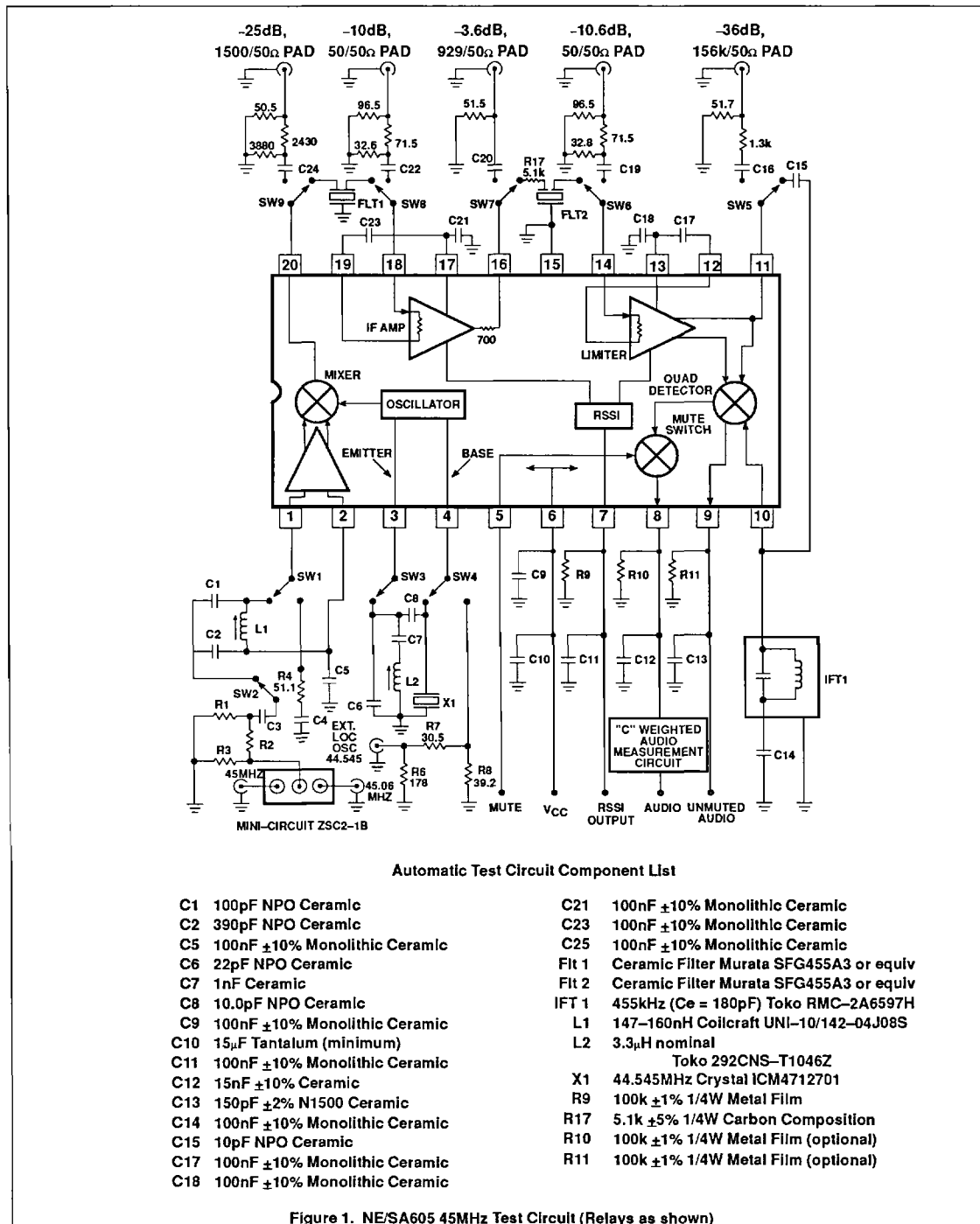

High performance low power mixer FM IF system

NE/SA605

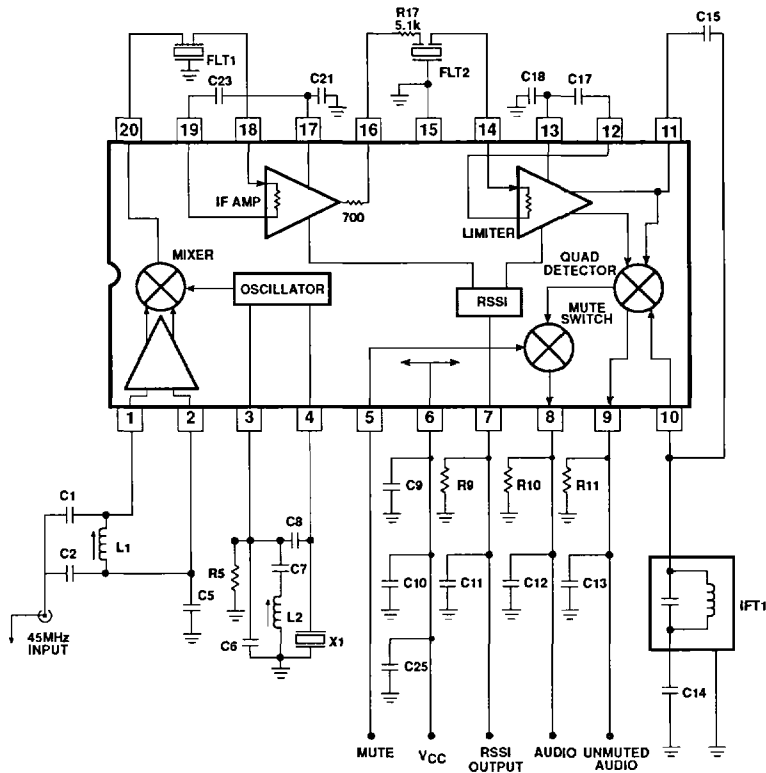

Application Component List

C1	100pF NPO Ceramic	C21	100nF $\pm 10\%$ Monolithic Ceramic
C2	390pF NPO Ceramic	C23	100nF $\pm 10\%$ Monolithic Ceramic
C5	100nF $\pm 10\%$ Monolithic Ceramic	C25	100nF $\pm 10\%$ Monolithic Ceramic
C6	22pF NPO Ceramic	Flt 1	Ceramic Filter Murata SFG455A3 or equiv
C7	1nF Ceramic	Flt 2	Ceramic Filter Murata SFG455A3 or equiv
C8	10.0pF NPO Ceramic	IFT 1	455kHz ($C_e = 180pF$) Toko RMC-2A6597H
C9	100nF $\pm 10\%$ Monolithic Ceramic	L1	147-160nH Colcraft UNI-10/142-04J08S
C10	15 μ F Tantalum (minimum)	L2	3.3 μ H nominal Toko 292CNS-T1046Z
C11	100nF $\pm 10\%$ Monolithic Ceramic	X1	44.545MHz Crystal ICM4712701
C12	15nF $\pm 10\%$ Ceramic	R9	100k $\pm 1\%$ 1/4W Metal Film
C13	150pF $\pm 2\%$ N1500 Ceramic	R17	5.1k $\pm 5\%$ 1/4W Carbon Composition
C14	100nF $\pm 10\%$ Monolithic Ceramic	R5	Not Used in Application Board (see Note 8)
C15	10pF NPO Ceramic	R10	100k $\pm 1\%$ 1/4W Metal Film (optional)
C17	100nF $\pm 10\%$ Monolithic Ceramic	R11	100k $\pm 1\%$ 1/4W Metal Film (optional)
C18	100nF $\pm 10\%$ Monolithic Ceramic		

Figure 2. NE/SA605 45MHz Application Circuit

High performance low power mixer FM IF system

NE/SA605

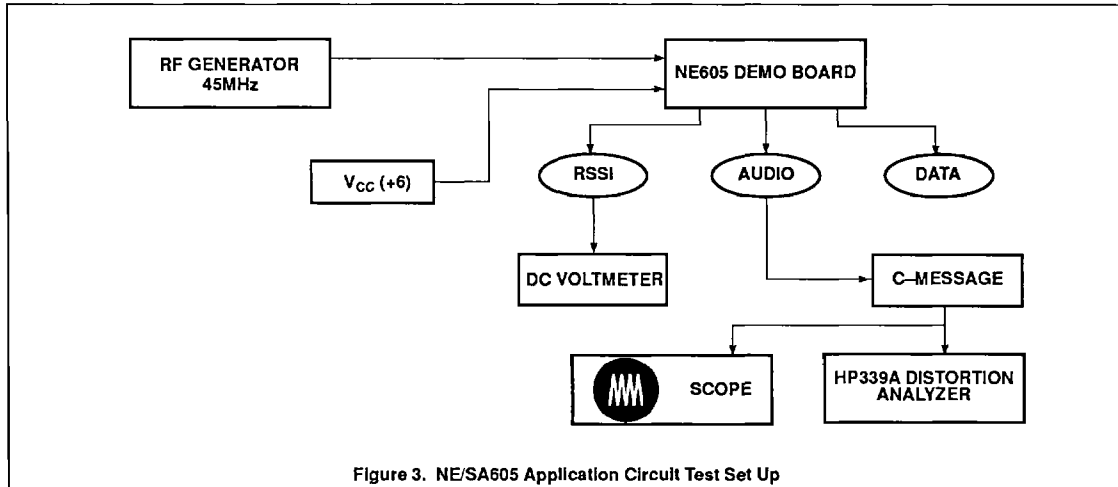

Figure 3. NE/SA605 Application Circuit Test Set Up

NOTES:

1. C-message: The C-message filter has a peak gain of 100 for accurate measurements. Without the gain, the measurements may be affected by the noise of the scope and HP339 analyzer.
2. Ceramic filters: The ceramic filters can be 30kHz SFG455A3s made by Murata which have 30kHz IF bandwidth (they come in blue), or 16kHz CFU455Ds, also made by Murata (they come in black). All of our specifications and testing are done with the more wideband filter.
3. RF generator: Set your RF generator at 45.000MHz, use a 1kHz modulation frequency and a 6kHz deviation if you use 16kHz filters, or 8kHz if you use 30kHz filters.
4. Sensitivity: The measured typical sensitivity for 12dB SINAD should be 0.22 μ V or -120dBm at the RF input.
5. Layout: The layout is very critical in the performance of the receiver. We highly recommend our demo board layout.
6. RSSI: The smallest RSSI voltage (i.e., when no RF input is present and the input is terminated) is a measure of the quality of the layout and design. If the lowest RSSI voltage is 250mV or higher, it means the receiver is in regenerative mode. In that case, the receiver sensitivity will be worse than expected.
7. Supply bypass and shielding: All of the inductors, the quad tank, and their shield must be grounded. A 10–15 μ F or higher value tantalum capacitor on the supply line is essential. A low frequency ESR screening test on this capacitor will ensure consistent good sensitivity in production. A 0.1 μ F bypass capacitor on the supply pin, and grounded near the 44.545MHz oscillator improves sensitivity by 2–3dB.
8. R5 can be used to bias the oscillator transistor at a higher current for operation above 45MHz. Recommended value is 22k Ω , but should not be below 10k Ω .

High performance low power mixer FM IF system

NE/SA605

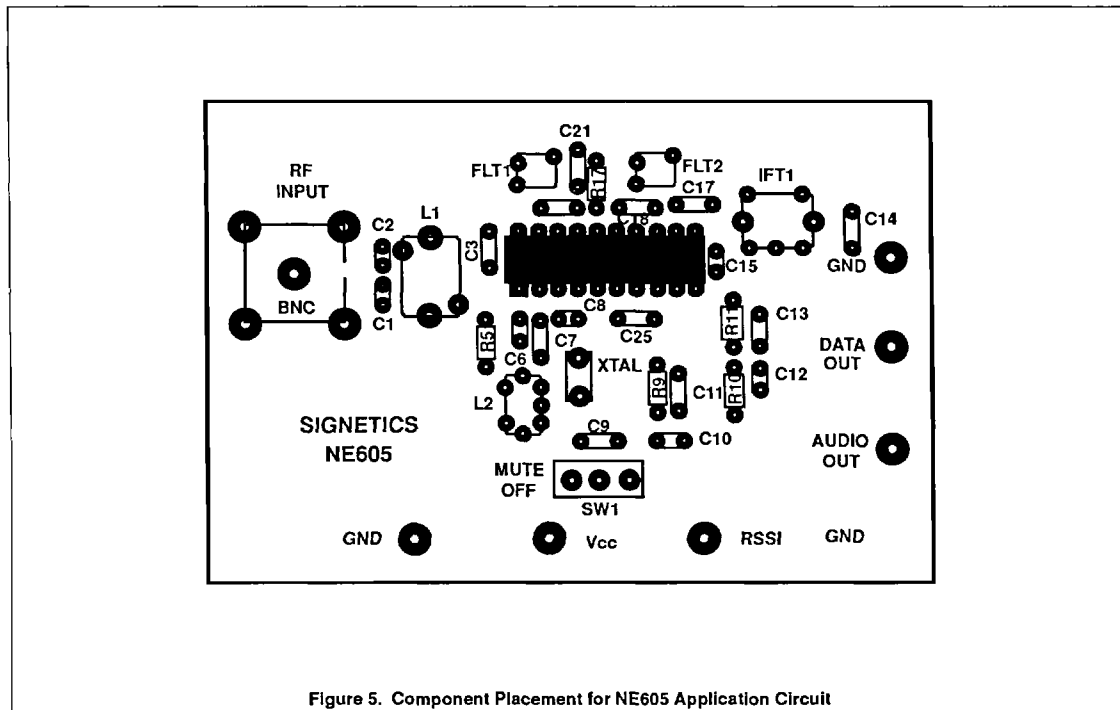
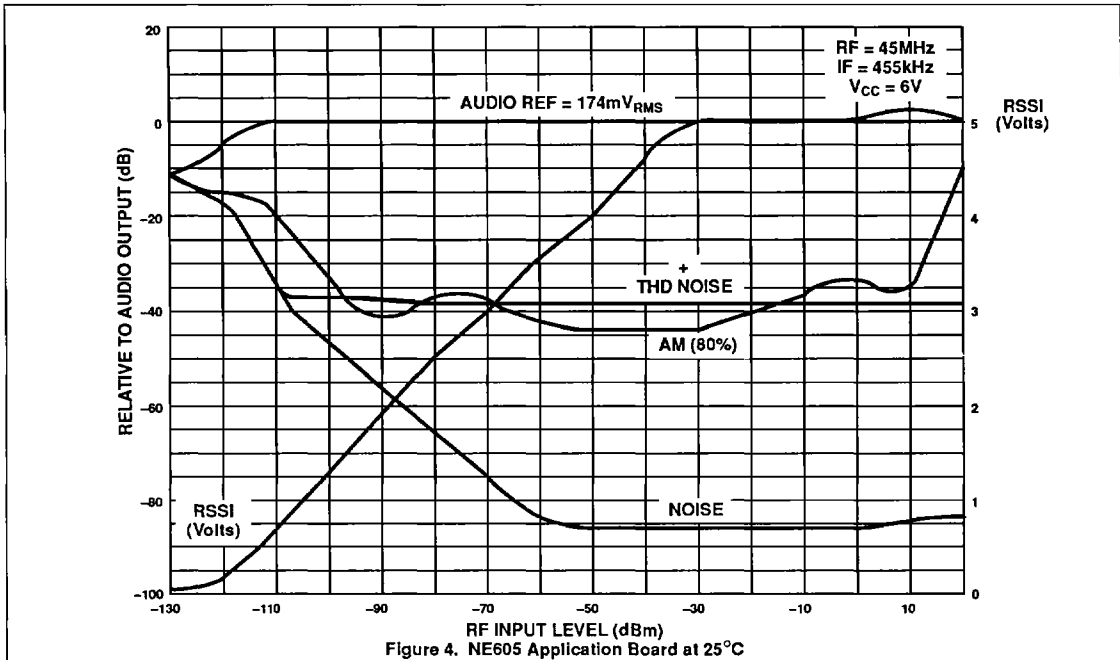

High performance low power mixer FM IF system

NE/SA605

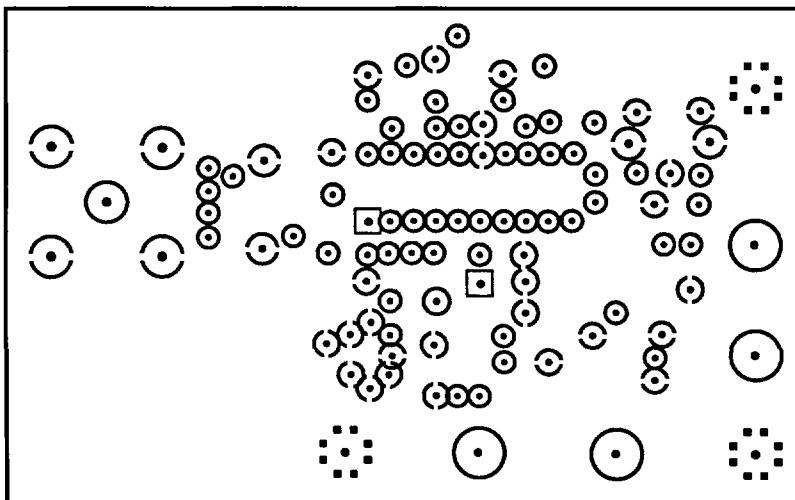

TOP VIEW

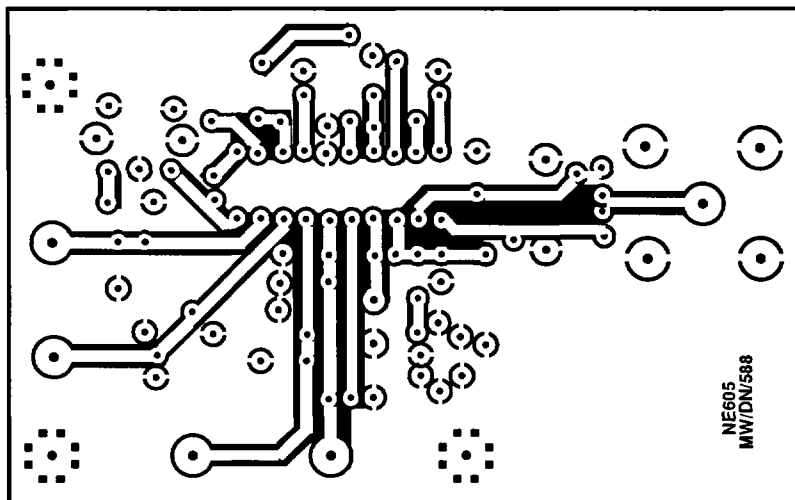

BOTTOM VIEW

Figure 6. Layout for NE/SA605 Application Board