

File Number 1670

Advance Information/  
Preliminary Data

CD54/74HC221  
CD54/74HCT221

T-51-19-00

High-Speed CMOS Logic

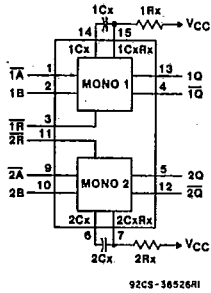

FUNCTIONAL DIAGRAM

Dual Monostable Multivibrator with Reset

Type Features:

- Overriding RESET Terminates Output Pulse
- Triggering From the Leading or Trailing Edge
- Q and Q-bar Buffered Outputs
- Separate Resets
- Wide Range of Output-Pulse Widths
- Schmitt Trigger on B Inputs

The RCA-CD54/74HC221 and CD54/74HCT221 are dual monostable multivibrators with reset. An external resistor ( $R_x$ ) and an external capacitor ( $C_x$ ) control the timing and the accuracy for the circuit. Adjustment of  $R_x$  and  $C_x$  provides a wide range of output pulse widths from the Q and Q-bar terminals. Pulse triggering on the B input occurs at a particular voltage level and is not related to the rise and fall time of the trigger pulse.

Once triggered, the outputs are independent of further trigger inputs on A and B. The output pulse can be terminated by a LOW level on the Reset (R) pin. Trailing-edge triggering (A) and leading-edge-triggering (B) inputs are provided for triggering from either edge of the input pulse. On power up, the IC is reset. If either Mono is not used each input (on the unused device) must be terminated either high or low.

The minimum value of external resistance,  $R_x$ , is typically 500Ω. The minimum value of external capacitance,  $C_x$ , is 0 pF. The calculation for the pulse width is  $t_w = 0.7 R_x C_x$  at  $V_{cc} = 4.5 V$ .

The CD54HC/HCT221 are supplied in 16-lead ceramic dual-in-line packages (F suffix). The CD74HC/HCT221 are supplied in 16-lead dual-in-line plastic packages (E suffix) and in 16-lead dual-in-line surface mount plastic packages (M suffix). Both types are also available in chip form (H suffix).

Family Features:

- Fanout (Over Temperature Range):  
Standard Outputs - 10 LSTTL Loads  
Bus Driver Outputs - 15 LSTTL Loads
- Wide Operating Temperature Range:  
CD74HC/HCT: -40 to +85°C
- Balanced Propagation Delay and Transition Times
- Significant Power Reduction Compared to LSTTL Logic ICs
- Alternate Source is Philips/Signetics
- CD54HC/CD74HC Types:  
2 to 6 V Operation  
High Noise Immunity:  
 $N_{IL} = 30\%$ ,  $N_{IH} = 30\%$  of  $V_{cc}$ ; @  $V_{cc} = 5 V$
- CD54HCT/CD74HCT Types:  
4.5 to 5.5 V Operation  
Direct LSTTL Input Logic Compatibility  
 $V_{IL} = 0.8 V$  Max.,  $V_{IH} = 2 V$  Min.  
CMOS Input Compatibility  
 $I_i \leq 1 \mu A$  @  $V_{OL}$ ,  $V_{OH}$

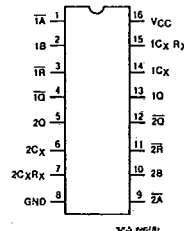

TERMINAL ASSIGNMENT

HARRIS SEMICONDUCTOR 27E D 430227J 0017698 3 HAS



CD54/74HC221  
CD54/74HCT221

STATIC ELECTRICAL CHARACTERISTICS

CHARACTERISTIC	CD74HC221/CD54HC221										CD74HCT221/CD54HCT221								UNITS			
	TEST CONDITIONS			74HC/54HC TYPES			74HC TYPES		54HC TYPES		TEST CONDITIONS		74HCT/54HCT TYPES			74HCT TYPES		54HCT TYPES				
	V <sub>I</sub> V	I <sub>O</sub> mA	V <sub>CC</sub> V	+25°C			-40/ +85°C		-55/ +125°C		V <sub>I</sub> V	V <sub>CC</sub> V	+25°C			-40/ +85°C		-55/ +125°C				
				Min	Typ	Max	Min	Max	Min	Max			Min	Max	Min	Max	Min	Max				
High-Level Input Voltage V <sub>IH</sub>			2	1.5	—	—	1.5	—	1.5	—	—	4.5									V	
			4.5	3.15	—	—	3.15	—	3.15	—	—	to	2	—	—	2	—	2	—			
			6	4.2	—	—	4.2	—	4.2	—	—	5.5										
Low-Level Input Voltage V <sub>IL</sub>			2	—	—	0.5	—	0.5	—	0.5	—	4.5									V	
			4.5	—	—	1.35	—	1.35	—	1.35	—	to	—	—	0.8	—	0.8	—	0.8	—		
			6	—	—	1.8	—	1.8	—	1.8	—	5.5										
High-Level Output Voltage V <sub>OH</sub>	V <sub>IL</sub> or V <sub>IH</sub>	-0.02	2	1.9	—	—	1.9	—	1.9	—	V <sub>IL</sub>										V	
			4.5	4.4	—	—	4.4	—	4.4	—	or	4.5	4.4	—	—	4.4	—	4.4	—			
			6	5.9	—	—	5.9	—	5.9	—	V <sub>IH</sub>											
TTL Loads	V <sub>IL</sub> or V <sub>IH</sub>										V <sub>IL</sub>										V	
		-4	4.5	3.98	—	—	3.84	—	3.7	—	or	4.5	3.98	—	—	3.84	—	3.7	—			
		-5.2	6	5.48	—	—	5.34	—	5.2	—	V <sub>IH</sub>											
Low-Level Output Voltage V <sub>OL</sub>	V <sub>IL</sub> or V <sub>IH</sub>	0.02	2	—	—	0.1	—	0.1	—	0.1	V <sub>IL</sub>										V	
			4.5	—	—	0.1	—	0.1	—	0.1	—	or	4.5	—	—	0.1	—	0.1	—	0.1		
			6	—	—	0.1	—	0.1	—	0.1	—	V <sub>IH</sub>										
TTL Loads	V <sub>IL</sub> or V <sub>IH</sub>										V <sub>IL</sub>										V	
		4	4.5	—	—	0.26	—	0.33	—	0.4	or	4.5	—	—	0.26	—	0.33	—	0.4			
		5.2	6	—	—	0.26	—	0.33	—	0.4	V <sub>IH</sub>											
Input Leakage Current I <sub>I</sub>	V <sub>CC</sub> or Gnd		6	—	—	±0.1	—	±1	—	±1	Any Voltage Between V <sub>CC</sub> & Gnd	5.5	—	—	±0.1	—	±1	—	±1		μA	
Quiescent Device Current I <sub>CC</sub>	V <sub>CC</sub> or Gnd	0	6	—	—	8	—	80	—	160	V <sub>CC</sub> or Gnd	5.5	—	—	8	—	80	—	160		μA	
Additional Quiescent Device Current per Input pin: 1 unit load ΔI <sub>CC</sub> *											V <sub>CC</sub> -2.1 to 5.5	—	—	100	360	—	450	—	490		μA	

\*For dual-supply systems theoretical worst case (V<sub>I</sub> = 2.4 V, V<sub>CC</sub> = 5.5 V) specification is 1.8 mA.

HCT Input Loading Table

Input	Unit Loads*
All Inputs	0.3

\*Unit Load is ΔI<sub>CC</sub> limit specified in Static Characteristic Chart, e.g., 360 μA max. @ 25°C.

**CD54/74HC221**  
**CD54/74HCT221**

**MAXIMUM RATINGS, Absolute-Maximum Values:**

DC SUPPLY-VOLTAGE, (V<sub>CC</sub>):  
(Voltages referenced to ground) ..... -0.5 to +7 V

DC INPUT DIODE CURRENT, I<sub>IK</sub> (FOR V<sub>i</sub> < -0.5 V OR V<sub>i</sub> > V<sub>CC</sub> + 0.5V) ..... ±20mA

DC OUTPUT DIODE CURRENT, I<sub>OK</sub> (FOR V<sub>o</sub> < -0.5 V OR V<sub>o</sub> > V<sub>CC</sub> + 0.5V) ..... ±20mA

DC DRAIN CURRENT, PER OUTPUT (I<sub>o</sub>) (FOR -0.5 V < V<sub>o</sub> < V<sub>CC</sub> + 0.5V) ..... ±25mA

DC V<sub>CC</sub> OR GROUND CURRENT (I<sub>CC</sub>) ..... ±50mA

POWER DISSIPATION PER PACKAGE (P<sub>D</sub>):  
For T<sub>A</sub> = -40 to +60° C (PACKAGE TYPE E) ..... 500 mW  
For T<sub>A</sub> = +60 to +85° C (PACKAGE TYPE E) ..... Derate Linearly at 8 mW/°C to 300 mW  
For T<sub>A</sub> = -55 to +100° C (PACKAGE TYPE F, H) ..... 500 mW  
For T<sub>A</sub> = +100 to +125° C (PACKAGE TYPE F, H) ..... Derate Linearly at 8 mW/°C to 300 mW  
For T<sub>A</sub> = -40 to +70° C (PACKAGE TYPE M) ..... 400 mW  
For T<sub>A</sub> = +70 to +125° C (PACKAGE TYPE M) ..... Derate Linearly at 6 mW/°C to 70 mW

OPERATING-TEMPERATURE RANGE (T<sub>A</sub>):  
PACKAGE TYPE F, H ..... -55 to +125° C  
PACKAGE TYPE E, M ..... -40 to +85° C

STORAGE TEMPERATURE (T<sub>stg</sub>) ..... -65 to +150° C

LEAD TEMPERATURE (DURING SOLDERING):  
At distance 1/16 ± 1/32 in. (1.59 ± 0.79 mm) from case for 10 s max. .... +265° C  
Unit inserted into a PC Board (min. thickness 1/16 in., 1.59 mm)  
with solder contacting lead tips only ..... +300° C

**RECOMMENDED OPERATING CONDITIONS:**

For maximum reliability, nominal operating conditions should be selected so that operation is always within the following ranges:

CHARACTERISTIC	LIMITS		UNITS
	MIN.	MAX.	
Supply-Voltage Range (For T <sub>A</sub> = Full Package-Temperature Range) V <sub>CC</sub> .*			
CD54/74HC Types	2	6	V
CD54/74HCT Types	4.5	5.5	V
DC Input or Output Voltage V <sub>i</sub> , V <sub>o</sub>	0	V <sub>CC</sub>	V
Operating Temperature T <sub>A</sub> :			
CD74 Types	-40	+85	°C
CD54 Types	-55	+125	°C
Input Rise and Fall Times t <sub>r</sub> , t <sub>f</sub> on Inputs $\bar{A}$ and $\bar{B}$			
at 2 V	0	1000	ns
at 4.5 V	0	500	ns
at 6 V	0	400	ns
Input Rise and Fall Times t <sub>r</sub> , t <sub>f</sub> on Input B			
at 2 V	0	Unlimited	ns
at 4.5 V	0	Unlimited	ns
at 6 V	0	Unlimited	ns

\*Unless otherwise specified, all voltages are referenced to Ground.

**SWITCHING CHARACTERISTICS (V<sub>CC</sub> = 5 V, T<sub>A</sub> = 25° C, Input t<sub>r</sub>, t<sub>f</sub> = 6 ns)**

CHARACTERISTIC	C <sub>L</sub> (pF)	TYPICAL		UNITS
		54/74HC	54/74HCT	
Propagation Delay				
$\bar{A}$ , B, $\bar{B}$ to Q	t <sub>PLH</sub>	15	18	ns
$\bar{A}$ , B, $\bar{B}$ to $\bar{Q}$	t <sub>PHL</sub>	15	14	ns
Power Dissipation Capacitance*	C <sub>PD</sub>	—	166	pF

\*C<sub>PD</sub> is used to determine the dynamic power consumption, per multivibrator.

P<sub>D</sub> = (C<sub>PD</sub> + C<sub>i</sub>) V<sub>CC</sub><sup>2</sup> f<sub>i</sub> + Σ (C<sub>L</sub> V<sub>CC</sub><sup>2</sup> f<sub>o</sub>) where: f<sub>i</sub> = input frequency, C<sub>L</sub> = output load capacitance, V<sub>CC</sub> = supply voltage, assuming f<sub>i</sub> ≪ 1/t<sub>w</sub>  
f<sub>o</sub> = output frequency.

HARRIS SEMICONDUCTOR  
27E D  
4302271  
0017701  
T HAS

**CD54/74HC221**  
**CD54/74HCT221**

PREREQUISITE FOR SWITCHING FUNCTION

HARRIS SEMICOND SECTOR

27E D ■ 430227J 0017702 J ■ HAS

CHARACTERISTIC	V <sub>CC</sub>	25°C				-40°C to +85°C				-55°C to +125°C				UNITS	
		HC		HCT		74HC		74HCT		54HC		54HCT			
		Min.	Max.	Min.	Max.	Min.	Max.	Min.	Max.	Min.	Max.	Min.	Max.		
Input Pulse Width $\bar{A}$	2	70	—	—	—	90	—	—	—	105	—	—	—	ns	
	4.5	14	—	14	—	18	—	18	—	21	—	21	—		
	6	12	—	—	—	15	—	—	—	18	—	—	—		
B	2	70	—	—	—	90	—	—	—	105	—	—	—	ns	
	4.5	14	—	14	—	18	—	18	—	21	—	21	—		
	6	12	—	—	—	15	—	—	—	18	—	—	—		
Reset	2	70	—	—	—	90	—	—	—	105	—	—	—	ns	
	4.5	14	—	18	—	18	—	23	—	21	—	27	—		
	6	12	—	—	—	15	—	—	—	18	—	—	—		
Recovery Time $\bar{R}$ to $\bar{A}$ or B	2	0	—	—	—	0	—	—	—	0	—	—	—	ns	
	4.5	0	—	0	—	0	—	0	—	0	—	0	—		
	6	0	—	—	—	0	—	—	—	0	—	—	—		
Output Pulse Width Q or $\bar{Q}$ $C_x = 0.1 \mu F, R_x = 10k \Omega$	t <sub>w</sub>	5	630	770	630	770	602	798	602	798	595	805	595	805	μs
		4.5	Typical 140		Typical 140		—	—	—	—	—	—	—	—	ns
Output Pulse Width Q or $\bar{Q}$ $C_x = 28 pF, R_x = 2K \Omega$	t <sub>w</sub>	4.5	1.5		1.5		—	—	—	—	—	—	—	μs	
		4.5	7		7		—	—	—	—	—	—	—	μs	

SWITCHING CHARACTERISTICS (C<sub>L</sub> = 50 pF, Input t<sub>r</sub> = 6 ns)

CHARACTERISTIC	SYMBOL	V <sub>CC</sub>	25°C				-40°C to +85°C				-55°C to +125°C				UNITS
			HC		HCT		74HC		74HCT		54HC		54HCT		
			Min.	Max.	Min.	Max.	Min.	Max.	Min.	Max.	Min.	Max.	Min.	Max.	
Propagation Delay, Trigger $\bar{A}, B, \bar{R}$ to Q	t <sub>PLH</sub>	2	—	210	—	—	—	265	—	—	—	315	—	—	ns
		4.5	—	42	—	42	—	53	—	53	—	63	—	63	
		6	—	36	—	—	—	45	—	—	—	54	—	—	
$\bar{A}, B, \bar{R}$ to $\bar{Q}$	t <sub>PHL</sub>	2	—	170	—	—	—	215	—	—	—	255	—	—	ns
		4.5	—	34	—	34	—	43	—	43	—	51	—	51	
		6	—	29	—	—	—	37	—	—	—	43	—	—	
Propagation Delay $\bar{R}$ to Q	t <sub>PLH</sub>	2	—	160	—	—	—	200	—	—	—	240	—	—	ns
		4.5	—	32	—	38	—	40	—	48	—	48	—	57	
		6	—	27	—	—	—	34	—	—	—	41	—	—	
$\bar{R}$ to $\bar{Q}$	t <sub>PHL</sub>	2	—	180	—	—	—	225	—	—	—	270	—	—	ns
		4.5	—	36	—	37	—	45	—	46	—	54	—	56	
		6	—	31	—	—	—	38	—	—	—	46	—	—	
Output Transition Time	t <sub>TLH</sub> t <sub>THL</sub>	2	—	75	—	—	—	95	—	—	—	110	—	—	ns
		4.5	—	15	—	15	—	19	—	19	—	22	—	22	
		6	—	13	—	—	—	16	—	—	—	19	—	—	
Input Capacitance	C <sub>in</sub>		—	10	—	10	—	10	—	10	—	10	—	pF	
Pulse Width match between circuits in the same package C <sub>x</sub> =1000 pF, R <sub>x</sub> =10KΩ		4.5 to 5.5	Typical ±2		Typical ±2		—	—	—	—	—	—	—	%	

**CD54/74HC221**  
**CD54/74HCT221**

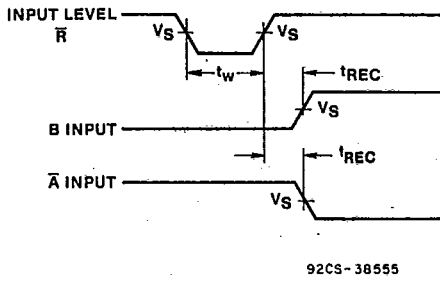

Fig. 2 — Recovery times,  $\bar{R}$  to  $\bar{A}$  or B.

	54/74HC	54/74HCT
Input Level	VCC	3 V
Switching Voltage, $V_S$	50% VCC	1.3 V

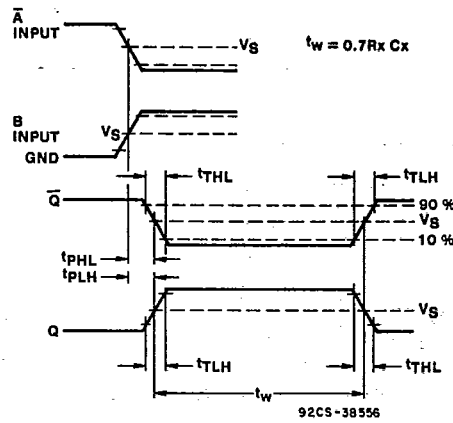

Fig. 3 — Triggering of One Shot by Input  $\bar{A}$  or Input B in a period  $t_w$ .

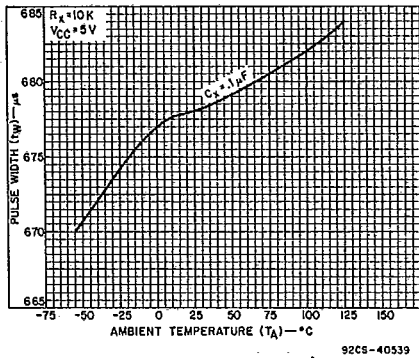

Fig. 4 — HC/HCT221 Output Pulse Width vs. Temperature.

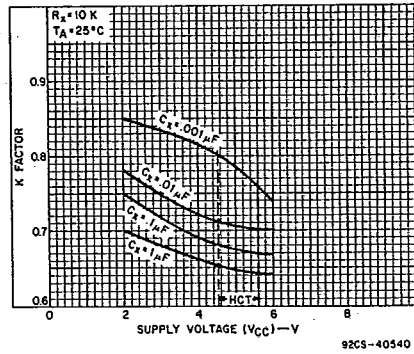

Fig. 5 — HC/HCT221 K Factor vs. Supply Voltage.

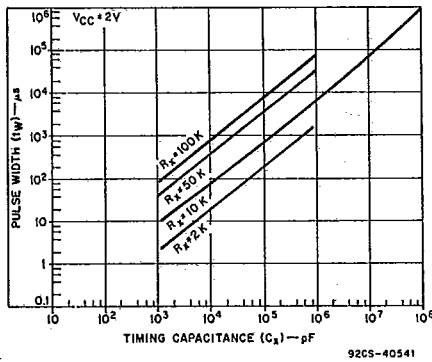

Fig. 6 — HC221 Output Pulse Width vs.  $C_x$ .

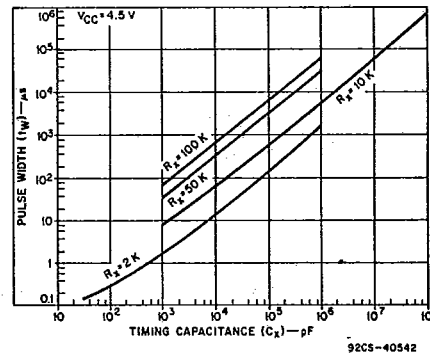

Fig. 7 — HC/HCT221 Output Pulse Width vs.  $C_x$ .

HARRIS SEMICONDUCTOR 27E D 430227J 0017703 3 HAS

**CD54/74HC221**  
**CD54/74HCT221**

HARRIS SEMICONDUCTOR

27E D 4302271 0017704 5 HAS

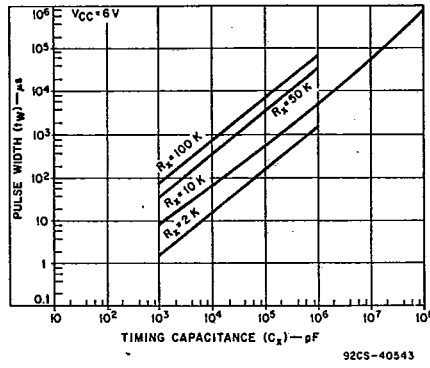

Fig. 8 — HC221 Output Pulse Width vs.  $C_x$ .

