

1 Overview

1.1 Features

Stereo-Soundprocessing

- Three stereo AF inputs, one of the inputs is equipped with floating ground.
- Input level control for individual level setting of the several AF sources in addition with a clipping detector.
- Volume control with software controlled switchable loudness function. Frequency response fixed by external components.
- Bass- and treble control with clipping detector.
- Four independent settable output attenuators for balance/fader function.
- Fan-out of the AF outputs software controlled.
- AF outputs switchable for driving bride power amplifiers.
- I²C Bus controlled immediately, or zero cross detector dependent mute, or immediately mute via extra pin.

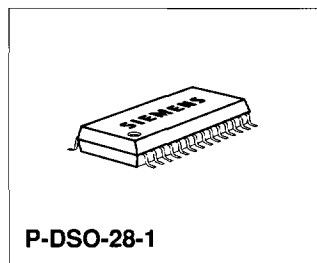

Control Part

- I²C Bus interface
- Control of sound processing
- Read out of the clipping detector status.

Type	Ordering Code	Package
TDA 4350X	Q67000-A5060	P-DSO-28-1

1.2 Application

The TDA 4350X is a single-chip audio-soundsystem. The circuit can be partitioned into two functional blocks: stereo-soundprocessing and control part.

1.3 Pin Configuration (top view)

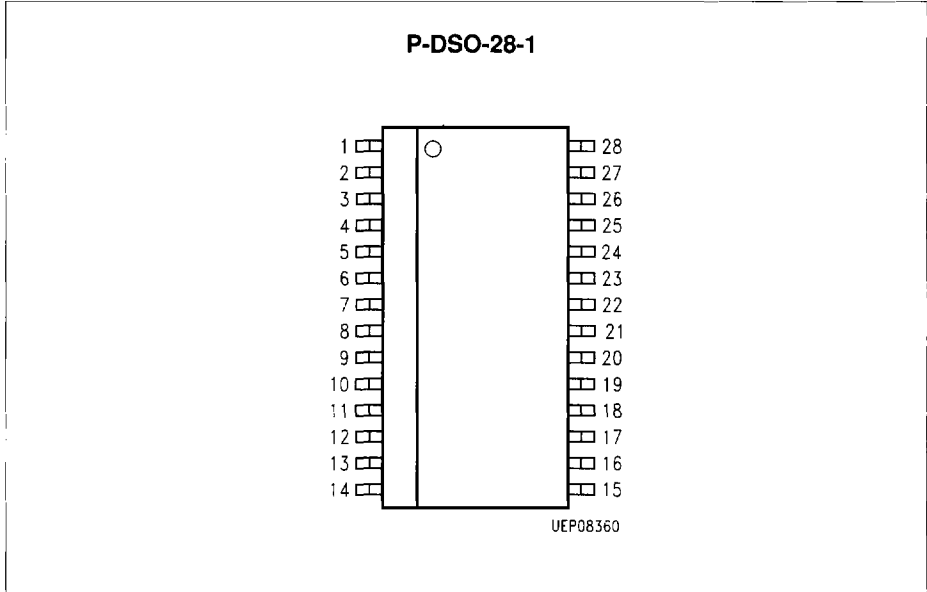

Figure 1

1.4 Pin Definitions and Functions

Pin No.	Function
1	CD input right
2	Input 2 right
3	Input 3 right
4	Loudness output right
5	Loudness input right
6	Digital ground
7	Mute
8	I ² C Bus SCL
9	I ² C Bus SDA
10	+ V_s supply voltage
11	Corner frequency treble left
12	Corner frequency treble right
13	AF output right front
14	AF output right rear
15	AF output left rear
16	AF output left front
17	RC network bass right
18	RC network bass right
19	RC network bass left
20	RC network bass left
21	Analog ground
22	Bias for AF operation point
23	Loudness output left
24	Loudness input left
25	Input 3 left
26	Input 2 left
27	CD ground
28	CD input left

1.5 Functional Block Diagram

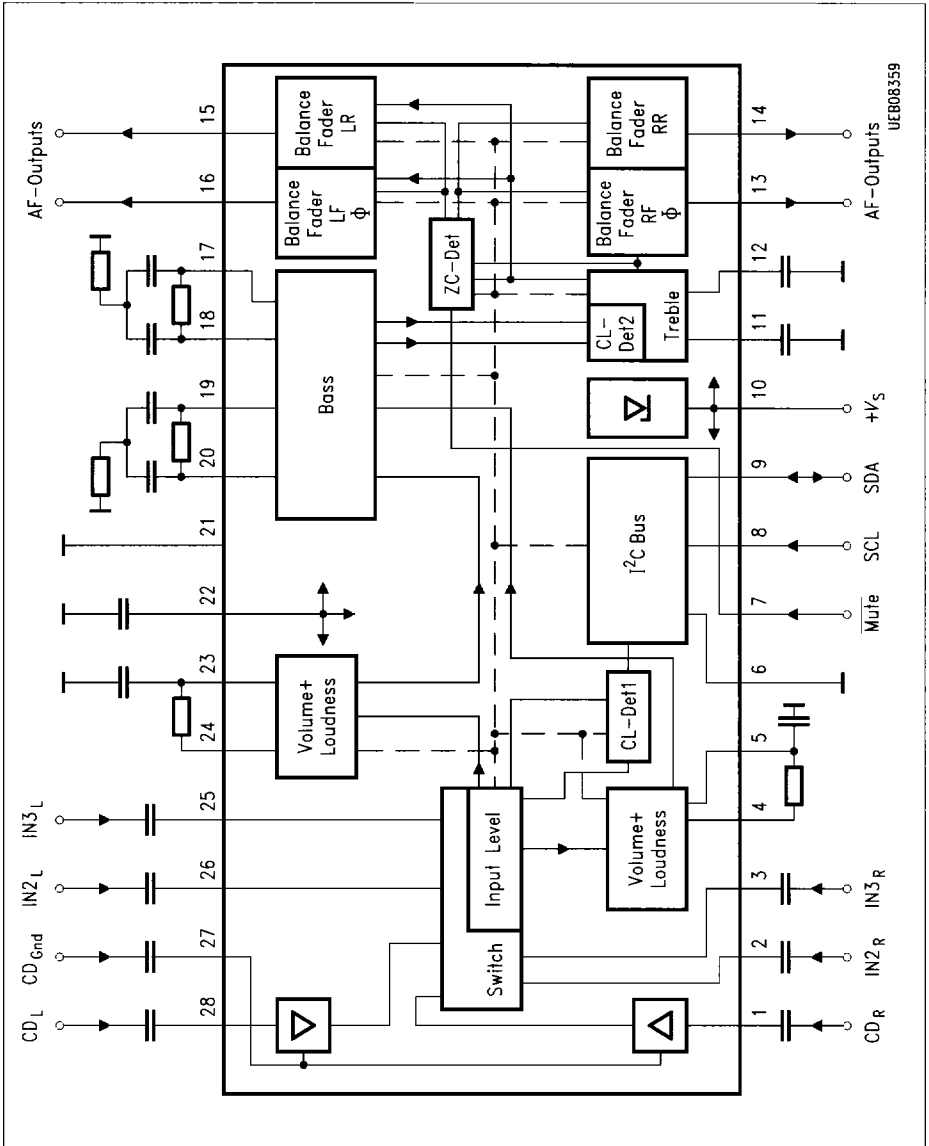

Figure 2
Block Diagram

2 Circuit Description

2.1 Signalprocessing

1. The selection of the AF inputs happens in the input switch. There are three stereo-inputs available. One of the input pairs is equipped with a separate floating ground connection especially provided for external signal sources. Crosstalk to this input is suppressed by common mode rejection. An input level control circuitry behind input switch realizes the adaption of different signal source levels. The circuit offers a control range from 0 dB to + 25 dB with a stepwidth of 2.5 dB. An I²C Bus controlled first clipping detector allows a software controlled level adaption.
2. Next stage in signal path is volume control, with common setting for both channels, a control range of 0 dB to - 78.75 dB and a stepwidth of 1.25 dB. In this stage a loudness function is realized. A loudness control circuit, in fact a second volume control circuit with identical structure, is to be set to a higher level as volume control. The resulting level difference fixes the maximum amplitude response of the loudness function. The frequency response, only bass boost or combined bass and treble boost is fixed by external components. Because the volume and loudness control are strictly independent of each other, the frequency response and threshold of the loudness function is programmable via software. A switch bit allows to enable the loudness function easily. Some possible loudness setups:

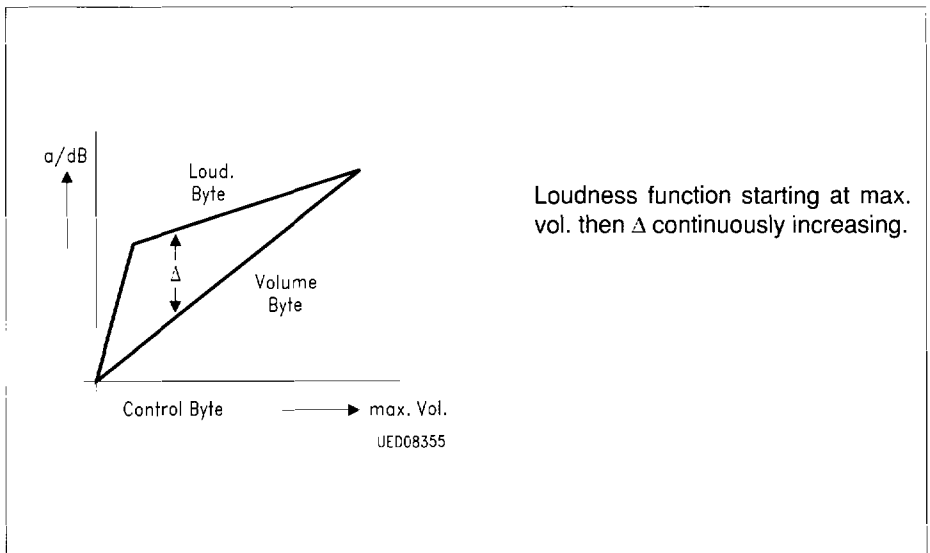

Figure 3

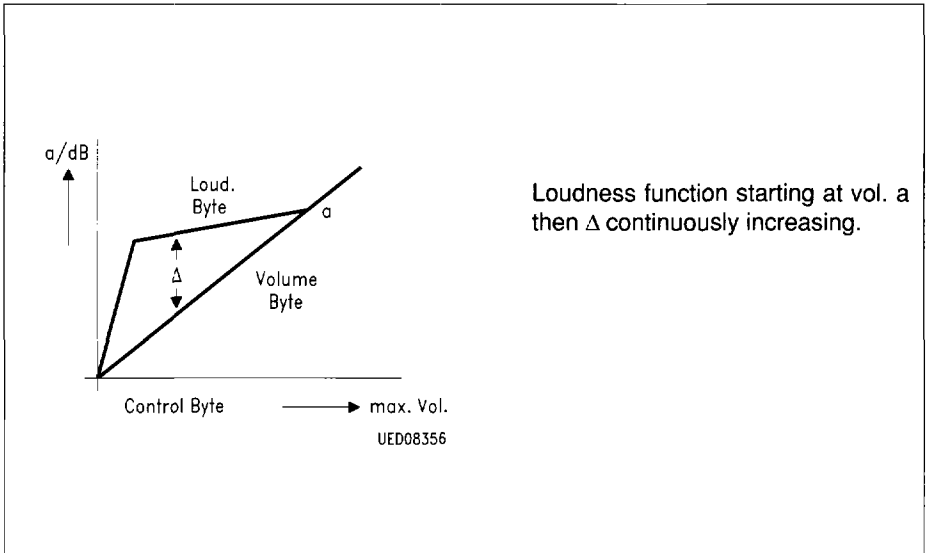

Figure 4

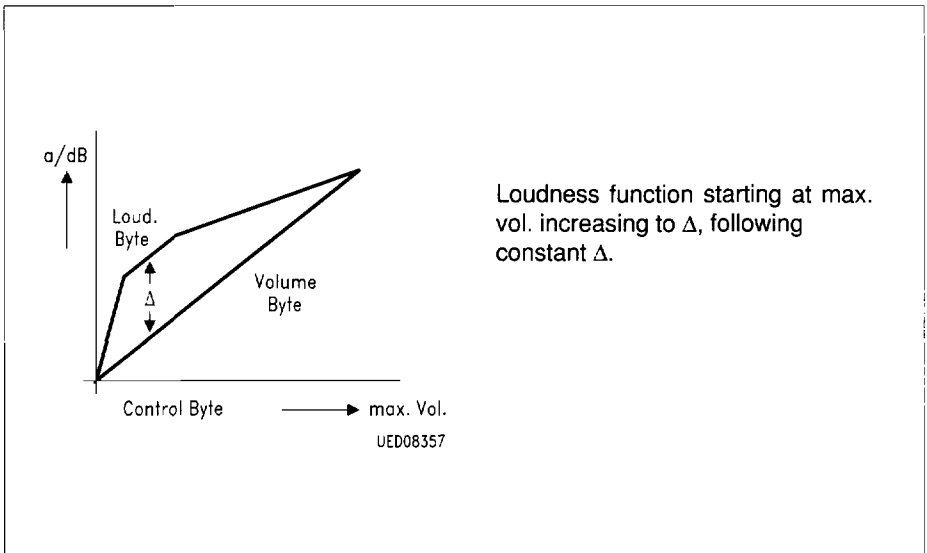

Figure 5

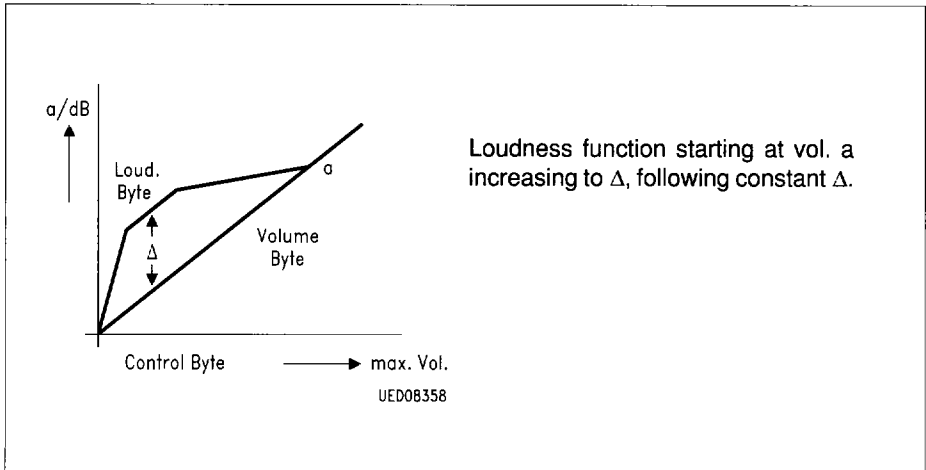

Figure 6

3. In the following signalpath there is tone control, consisting of bass and treble control. Bass control offers a control range of + 16 dB to – 14 dB with a stepwidth of 2 dB. Frequency characteristic, 1st order or 2nd order (resonance type) is fixed by external components. Treble control also offers a control range of + 16 dB to – 14 dB with a stepwidth of 2 dB. The treble control corner frequency is determined by an external capacitor.

A second clipping detector allows to detect clipping in tone control part.

4. Last stages in signal path are four strictly independent controllable output attenuators to realize balance and fader function. Each unit offers a control range of 0 dB to – 38.75 dB in steps of 1.25 dB. The AF outputs are of a class A-type to avoid distortion via software, the output fan-out can be increased to drive loads up to > 1.5 k Ω .

One output of each stereo channel can be inverted software controlled, to drive easily bridge power amplifiers.

5. Mute control may be either done via the volume control setting, or directly for all outputs by setting the IM (immediately mute) bit via I²C Bus. The second bus controlled mute mode is mute after signal zero crossing (ZCM). Two zero cross detectors are built-in, therefore this mute control works independent for left and right channel. Signal off- and on-switching is performed under zero cross detector control. The ZCM status can be read out via I²C Bus (ZCS). After activating ZCM, the ZCS (zero crossing status) bit is set to '1', when all outputs are muted after zero crossing. After deactivating ZCM, the ZCS bit is set to '0' when all outputs are switched on after zero crossing. The IM mute overwrites ZCM mute. Third mute control is hardware mute via a mute pin. If the mute pin is switched to ground all outputs are muted immediately. Hardware mute overwrites all other mute modes.

2.2 Controlpart

All functions are controlled via an I²C Bus interface. All data are stored into a latch circuit. The telegram structure is built as follows:

Startcondition – chipaddress – any number of databytes – stopcondition.

For the databytes the following conditions must be fulfilled:

Before transmitting a databyte a subaddress byte must first be placed in the data telegram.

2.2.1 Chipaddress

MSB							LSB
1	0	0	0	0	1	1	R/W
R/W = '0' → Read				R/W = '1' → Write			

2.2.2 Subaddress Bytes

	MSB						LSB	
Switchbyte	0	0	0	0	0	0	0	0
Inputlevel	0	0	0	0	0	0	0	1
Volume	0	0	0	0	0	0	1	0
Loudness	0	0	0	0	0	0	1	1
Bass/Treble	0	0	0	0	0	1	0	0
Out rear left	0	0	0	0	0	1	0	1
Out front left	0	0	0	0	0	1	1	0
Out rear right	0	0	0	0	0	1	1	1
Out front right	0	0	0	0	1	0	0	0

2.2.3 Control Bytes

a) Switch Control Byte

MSB				LSB			
ZCM	IM	Fan	Ph	IN-3	IN-2	IN-CD	X
	IN-CD = '0'		CD input OFF; power ON				
	IN-CD = '1'		CD input ON				
	IN-2 = '0'		Input 2 OFF; power ON				
	IN-2 = '1'		Input 2 ON				
	IN-3 = '0'		Input 3 OFF; power ON				
	IN-3 = '1'		Input 3 ON				
	If no input is selected, mute function is active.						
	If no protection against multiple selection implemented!						
	Ph = '0'		Bridgepower amplifier operation ON; power ON				
	Ph = '1'		Normal operation				
	Fan = '0'		Normal operation; power ON				
	Fan = '1'		Increased Fan out ON				
	IM = '0'		Normal operation; power ON				
	IM = '1'		Immediate mute for all AF outputs				
	ZCM = '0'		Normal operation; power ON				
	ZCM = '1'		Mute after signal zero crossing				
	IM overwrites ZCM, hardware mute overwrites all other mute modes.						

b) Input Level Control Byte

	MSB				LSB				
Min. gain	X	X	X	X	0	0	0	0	
Min. gain + 1	X	X	X	X	0	0	0	1	power ON
Max. gain - 1	X	X	X	X	1	0	0	1	
Max. gain	X	X	X	X	1	0	1	0	
	to								
Max. gain	X	X	X	X	1	1	1	1	

c) Volume Level Control Byte

	MSB						LSB		
Min. gain	X	0	0	0	0	0	0	0	
Min. gain + 1	X	0	0	0	0	0	0	1	power ON
Max. gain - 1	X	0	1	1	1	1	1	0	
Max. gain	X	0	1	1	1	1	1	1	

d) Loudness Control Byte

	MSB						LSB		
Min. gain	X	Ld	0	0	0	0	0	0	
Min. gain + 1	X	Ld	0	0	0	0	0	1	power ON
Max. gain - 1	X	Ld	1	1	1	1	1	0	
Max. gain	X	Ld	1	1	1	1	1	1	

Ld = '0' Loudness OFF; power ON
 (loudness attenuator has the same setting
 as volume attenuator)

Ld = '1' Loudness ON

e) Treble/Bass Control Byte

	MSB				LSB			
linear	1	0	0	0	1	0	0	0
max. treble, lin. bass	0	0	0	0	1	0	0	0
min. treble, lin. bass	1	1	1	1	1	0	0	0
lin. treble, max. bass	1	0	0	0	0	0	0	0
lin. treble, min. bass	1	0	0	0	1	1	1	1
max. treble, max. bass	0	0	0	0	0	0	0	0
min. treble, min. bass	1	1	1	1	1	1	1	1
power ON	0	0	0	0	0	0	0	1
	treble				bass			

f) Output Control Bytes

	MSB				LSB			
Min. gain	X	X	X	X	0	0	0	0
Min. gain + 1	X	X	X	X	0	0	0	1
Max. gain - 1	X	X	X	X	1	1	1	0
Max. gain	X	X	X	X	1	1	1	1

power ON

2.2.4 Talkmode

MSB

LSB

CI1	CI2	ZCS	X	X	X	X	X
-----	-----	-----	---	---	---	---	---

CI1 = '0' Normal operation
 CI1 = '1' Input level control output at clipping level
 CL 2 = '0' Normal operation
 CL2 = '1' Tone control output at clipping level
 ZCS = '0' All AF outputs are ON after ZCS set to '0'
 ZCS = '1' All AF outputs are muted after ZCM set to '1'

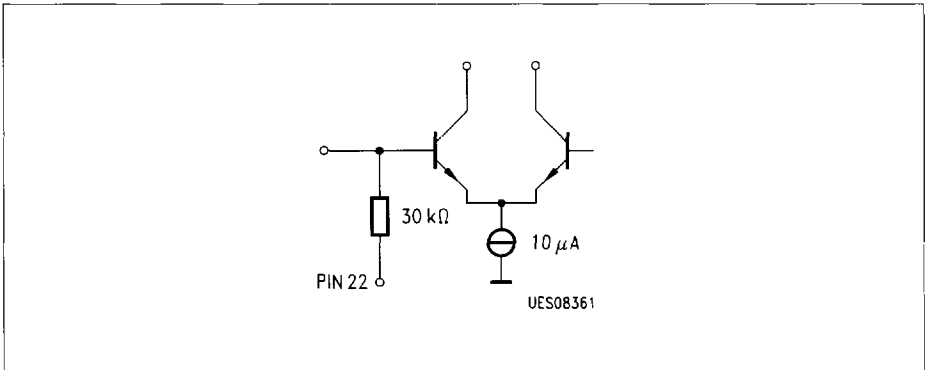

Figure 7
AF Inputs Pin 1/2/3/25/26/27/28

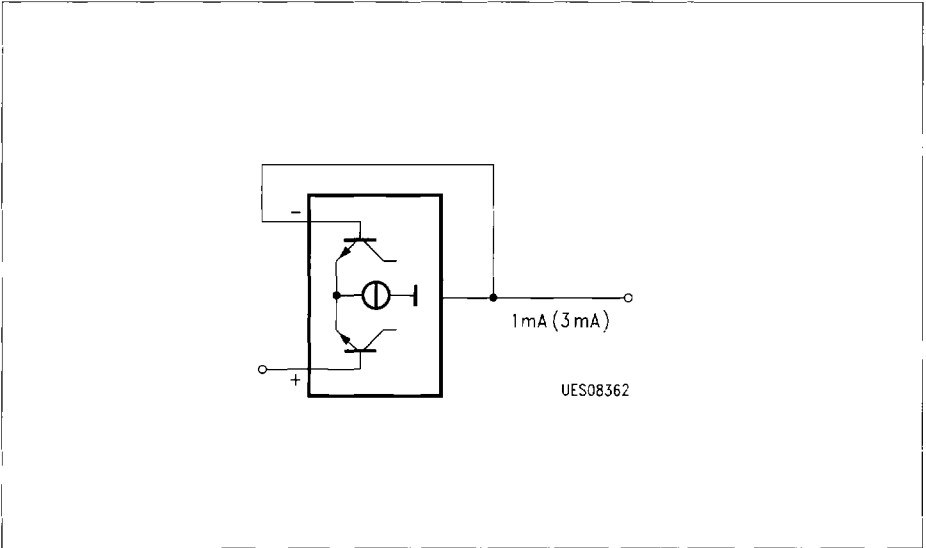

Figure 8
AF Outputs Pin 13/14/15/16

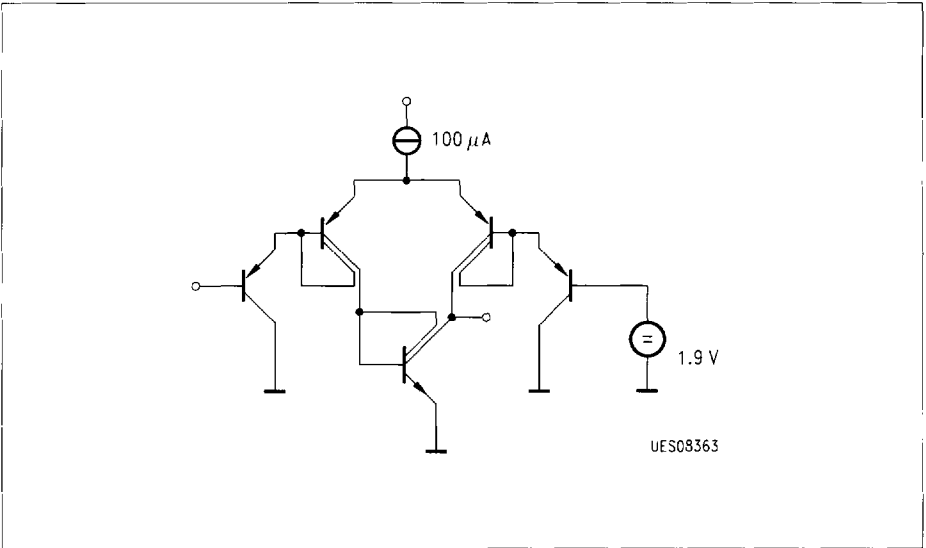

Figure 9
Mute Pin 7, I²C Bus SCL Pin 8

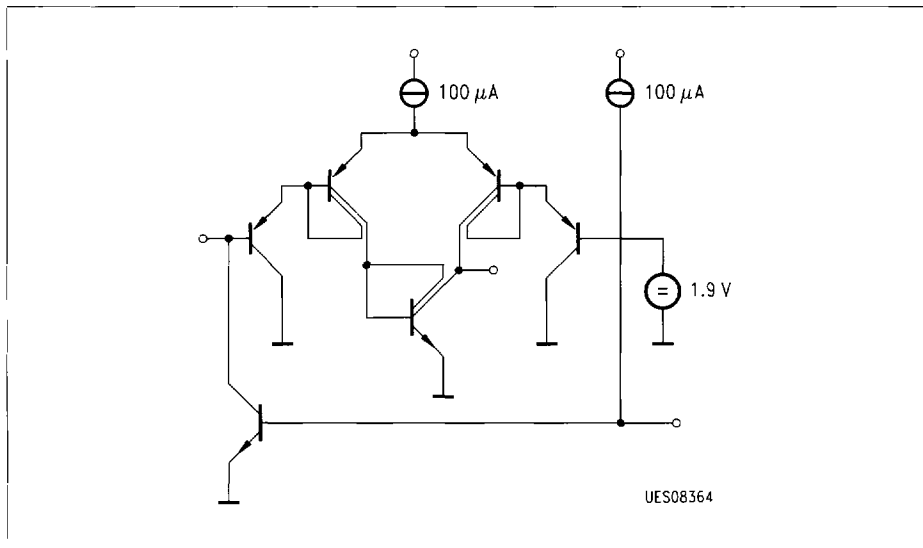

Figure 10
I²C Bus SDA Pin 9

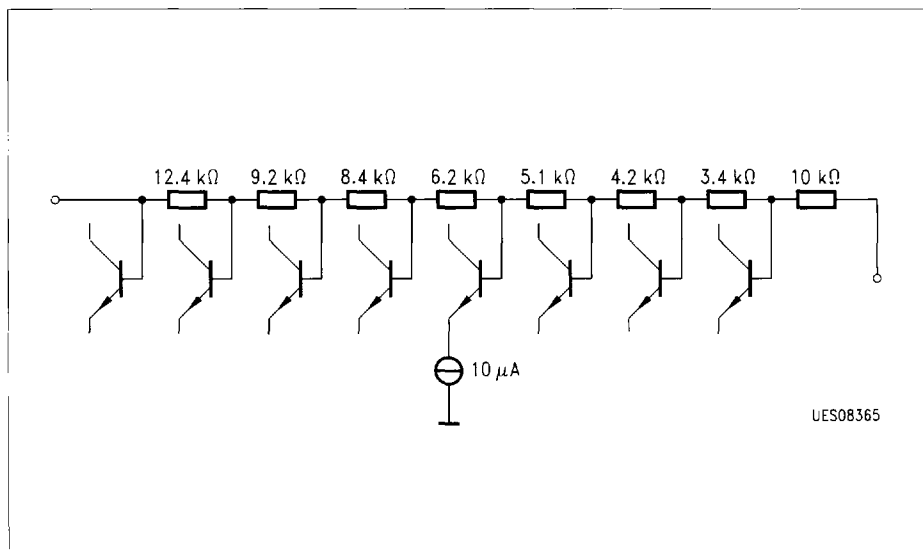

Figure 11
Corner Frequency Treble Pin 11/12

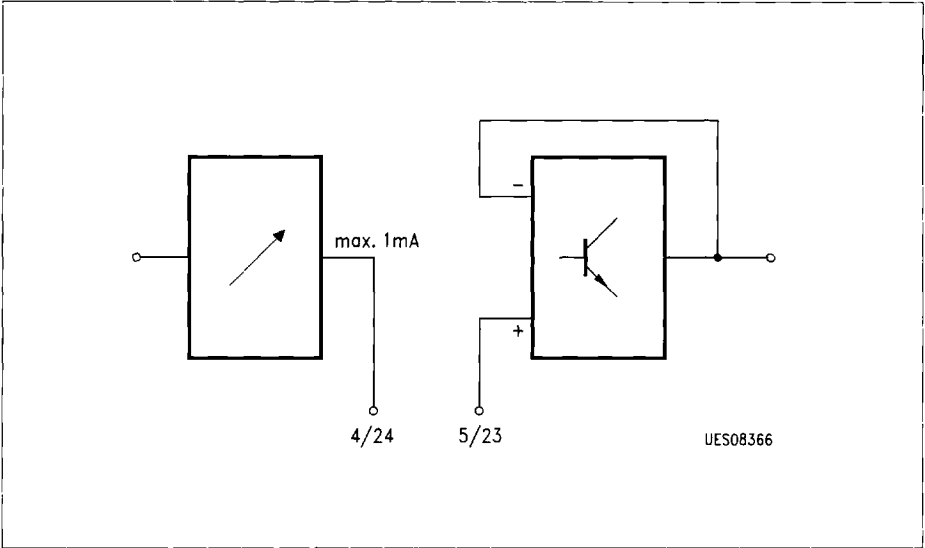

Figure 12
Loudness Pin 4/5/23/24

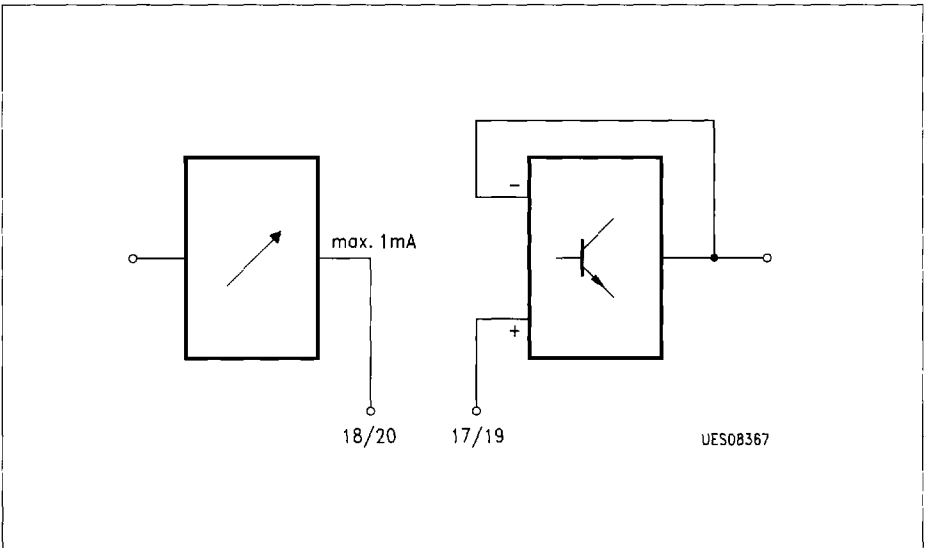

Figure 13
RC Network Bass Pin 17/18/19/20

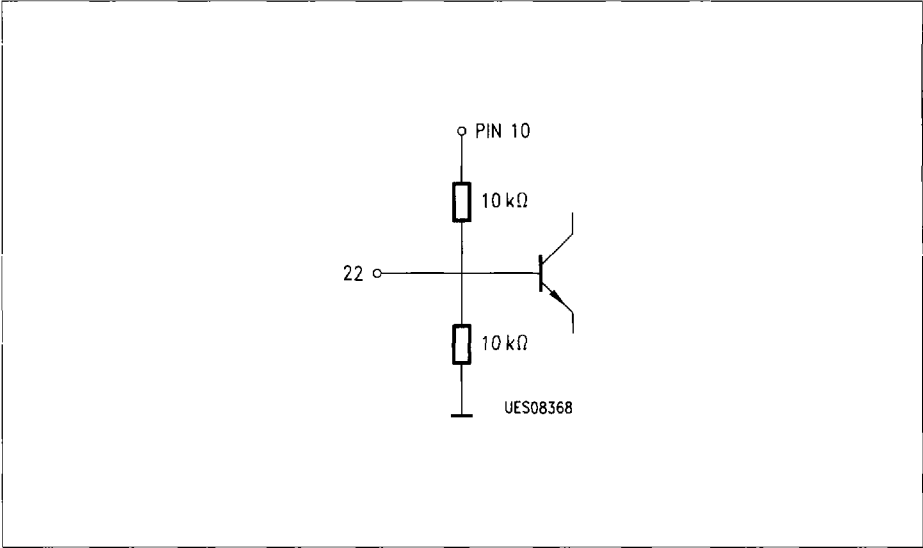

Figure 14
Bias for AF Operation Point Pin 22

3 Electrical Characteristics

3.1 Absolute Maximum Ratings

$T_A = -40\text{ °C}$ to 85 °C

Parameter	Symbol	Limit Values		Unit	Remarks
		min.	max.		
Supply voltage	V_{10}	0	14	V	
Max. DC voltage	V_1	0	V_{10}	V	
Max. DC voltage	V_2	0	V_{10}	V	
Max. DC voltage	V_3	0	V_{10}	V	
Max. DC voltage	V_5	0	V_{10}	V	
Max. DC voltage	V_7	0	V_{10}	V	
Max. DC voltage	V_8	0	V_{10}	V	
Max. DC voltage	V_9	0	V_{10}	V	
Max. DC voltage	V_{11}	0	V_{10}	V	
Max. DC voltage	V_{12}	0	V_{10}	V	
Max. DC voltage	V_{17}	0	V_{10}	V	
Max. DC voltage	V_{19}	0	V_{10}	V	
Max. DC voltage	V_{22}	0	V_{10}	V	
Max. DC voltage	V_{23}	0	V_{10}	V	
Max. DC voltage	V_{25}	0	V_{10}	V	
Max. DC voltage	V_{26}	0	V_{10}	V	
Max. DC voltage	V_{27}	0	V_{10}	V	
Max. DC voltage	V_{28}	0	V_{10}	V	
Max. DC current	I_4	0	2	mA	
Max. DC current	I_{13}	0	5	mA	
Max. DC current	I_{14}	0	5	mA	
Max. DC current	I_{15}	0	5	mA	
Max. DC current	I_{16}	0	5	mA	
Max. DC current	I_{18}	0	2	mA	
Max. DC current	I_{20}	0	2	mA	
Max. DC current	I_{24}	0	2	mA	

3.1 Absolute Maximum Ratings (cont'd)

$T_A = -40\text{ °C}$ to 85 °C

Parameter	Symbol	Limit Values		Unit	Remarks
		min.	max.		
Junction temperature	T_j		150	°C	
Storage temperature	T_g		125	°C	
Thermal resistance	R_{thSA}		76	K/W	
ESD voltage, HBM	V_{ESD1}	- 4	4	kV	1.5 kΩ, 100 pF
ESD voltage, AF outputs	V_{ESD2}	- 6	6	kV	1.5 kΩ, 100 pF

Note: Maximum ratings are absolute ratings; exceeding only one of these values may cause irreversible damage to the integrated circuit.

3.2 Operational Range

Parameter	Symbol	Limit Values		Unit
		min.	max.	
Supply voltage	V_S	7.5	13.2	V
Ambient temperature range	T_A	- 40	85	°C
Input frequency range	f_i	0.01	20	kHz

Note: In the operating range the functions given in the circuit description are fulfilled.

3.3 AC/DC Characteristics

$V_{10} = 10 \text{ V}; T_A = 25 \text{ }^\circ\text{C}$

Parameter	Symbol	Limit Values			Unit	Test Condition	Test Circuit
		min.	typ.	max.			
Current consumption	I_{10}		45		mA		1

Signal Section

Gain	G_{13-1}		0		dB		1
Gain	G_{14-1}		0		dB		1

Analogous values are apply for feeding in on pins 2 and 3.

Gain	G_{15-28}		0		dB		1
Gain	G_{16-28}		0		dB		1

Analogous values are apply for feeding in on pins 25 and 26.

Input Level Control

Min. gain	G_{13-1} G_{14-1} G_{15-28} G_{16-28}		0		dB		1
Max. gain	G_{13-1} G_{14-1} G_{15-28} G_{16-28}		25		dB	$01,0A V_{inp} 10$	1
Stepwidth	G_{13-1} G_{14-1} G_{15-28} G_{16-28}		2.5		dB	$01,X-01, X \pm 1$ $V_{inp} X - V_{inp} (X \pm 1)$	1

Analogous values are apply for feeding in on pins 2, 3, 25 and 26.

Threshold Clipping detector 1	$F_{1 C11}$ $F_{28 C11}$		1.9		Vrms		1
-------------------------------	-----------------------------	--	-----	--	------	--	---

3.3 AC/DC Characteristics (cont'd)

$V_{10} = 10 \text{ V}; T_A = 25 \text{ }^\circ\text{C}$

Parameter	Symbol	Limit Values			Unit	Test Condition	Test Circuit
		min.	typ.	max.			

Volume Control

Max. gain	G_{13-1} G_{14-1} G_{15-28} G_{16-28}		0		dB		1
Min. gain	G_{13-1} G_{14-1} G_{15-28} G_{16-28}		- 78.25		dB	02,00; 03,00 <i>Vol. 0; Loud. OFF</i>	1
Tracking error	ΔG_{13-14} ΔG_{15-16} ΔG_{13-16} ΔG_{14-15}			± 2	dB	02,3F-02,24; 03,3F <i>Vol. 63-36; Loud. OFF</i>	1
Stepwidth	ΔG_{13} ΔG_{14} ΔG_{15} ΔG_{16}		1.25		dB	02,X-02, (X ± 1) <i>Vol. X-Vol. (X ± 1)</i>	1

Loudness Control

Max. gain	$G_{4,1}$ G_{24-28}		- 6		dB	03,7F; 02,00 <i>Loud. ON</i>	1
Min. gain	$G_{4,1}$ G_{24-28}		- 84.75		dB	03,40; 02,00 <i>Loud. 0</i>	1
Tracking error	ΔG_{5-24}			± 2	dB	03,7F-03,64; 02,00 <i>Loud. 63-36; Loud. ON</i>	1
Stepwidth	ΔG_4 ΔG_{24}		1.25		dB	03,X-03, (X ± 1) <i>Loud. X-Loud. (X ± 1)</i>	1

3.3 AC/DC Characteristics (cont'd)

$V_{10} = 10 \text{ V}; T_A = 25 \text{ }^\circ\text{C}$

Parameter	Symbol	Limit Values			Unit	Test Condition	Test Circuit
		min.	typ.	max.			

Output Control

Max. gain	$G_{13,1}$ $G_{14,1}$ $G_{15,28}$ $G_{16,28}$		0		dB		1
Min. gain	$G_{13,1}$ $G_{14,1}$ $G_{15,28}$ $G_{16,28}$		-38.75		dB	08,00; Out 0 07,00; Out 0 05,00; Out 0 06,00; Out 0	1
Stepwidth	ΔG_{13} ΔG_{14} ΔG_{15} ΔG_{16}		1.25		dB	08,X-08, (X ± 1) OutX-Out (X ± 1) 07,X-07, (X ± 1) OutX-Out (X ± 1) 05,X-05, (X ± 1) OutX-Out (X ± 1) 06,X-06, (X ± 1) OutX-Out (X ± 1)	1

3.3 AC/DC Characteristics (cont'd)

$V_{10} = 10 \text{ V}; T_A = 25 \text{ }^\circ\text{C}$

Parameter	Symbol	Limit Values			Unit	Test Condition	Test Circuit
		min.	typ.	max.			

Bass Control

Bass boost	G_{13-1} G_{14-1} G_{15-28} G_{16-28}	14	16		dB	04,80; $f_1 = 40 \text{ Hz}$ <i>Bass min, Treble lin</i>	1
Bass cut	G_{13-1} G_{14-1} G_{15-28} G_{16-28}		- 14		dB	04,8F; $f_1 = 40 \text{ Hz}$ <i>Bass min, Treble lin</i>	1
Bass stepwidth	ΔG_{13} ΔG_{14} ΔG_{15} ΔG_{16}	1	2	3	dB	04,8X ($X \pm 1$) <i>BassX-Bass ($X \pm 1$)</i>	1

Treble Control

Treble boost	G_{13-1} G_{14-1} G_{15-28} G_{16-28}	14	16		dB	04,80; $f_1 = 15 \text{ kHz}$ <i>Treble max, Bass lin</i>	1
Treble cut	G_{13-1} G_{14-1} G_{15-28} G_{16-28}		- 14		dB	04,8F; $f_1 = 15 \text{ kHz}$ <i>Treble min, Bass lin</i>	1
Treble stepwidth	ΔG_{13} ΔG_{14} ΔG_{15} ΔG_{16}	1	2	3	dB	04,8X-04, ($X \pm 1$) 8 <i>TrebleX-Treble ($X \pm 1$)</i>	1
Tone linearity	ΔG_{13} ΔG_{14} ΔG_{15} ΔG_{16}	1	2	3	dB	04. 88-04, $f_1 = 40 \text{ Hz} \dots 15 \text{ kHz}$ <i>Treble, Bass lin</i>	1
Threshold clipping detector 2	$V_{1 \text{ Cl}2}$ $V_{28 \text{ Cl}2}$		380		mVrms	04,00 $f_1 = 40 \text{ Hz}$ or 15 kHz <i>Treble max, Bass max</i>	1

3.3 AC/DC Characteristics (cont'd)

$V_{10} = 10 \text{ V}; T_A = 25 \text{ }^\circ\text{C}$

Parameter	Symbol	Limit Values			Unit	Test Condition	Test Circuit
		min.	typ.	max.			
Channel separation	ΔG_{14-15} ΔG_{13-16}	80			dB	V_1 or $V_{28} = 300 \text{ mVrms}$	1
Analogous values apply for feeding on pins 2, 3, 25 and 26.							
Crosstalk attenuation input switch	$a_{in \text{ use}/out \text{ interf.}}$	80			dB	$V_{i \text{ use.}} = 0$ $V_{i \text{ interf.}} = 300 \text{ mVrms}$	1
Feed on pins 1-3 and 25, 26, 28, measured on pins 13-16.							
Attenuation mute	a_{1-13} a_{1-14} a_{28-15} a_{28-16}	80			dB	02,7F; $V_1 = 300 \text{ mVrms}$ <i>mute active</i> 00,20; $V_1 = 300 \text{ mVrms}$ <i>notselect</i> 02,7F; $V_{28} = 300 \text{ mVrms}$ <i>mute active</i> 00,20; $V_{28} = 300 \text{ mVrms}$ <i>notselect</i>	1
Max. input voltage	V_1	2			Vrms	$THD_{13} < 1 \%$ $THD_{14} < 1 \%$	1
	V_{28}	2			Vrms	$THD_{15} < 1 \%$ $THD_{16} < 1 \%$	1
Max. output voltage	V_{13}	2.2			Vrms	$THD_{13} < 1 \%$	1
	V_{14}					$01,07; V_{inp.7}$ $THD_{14} < 1 \%$	
	V_{15}					$01,07; V_{inp.7}$ $THD_{15} < 1 \%$	
	V_{16}					$01,07; V_{inp.7}$ $THD_{16} < 1 \%$ $01,07; V_{inp.7}$	
Distortion	THD_{13} THD_{14} THD_{15} THD_{16}		0.01	0.05	%	$V_1 = 300 \text{ mVrms}$ $V_{28} = 300 \text{ mVrms}$	1

3.3 AC/DC Characteristics (cont'd)

$V_{10} = 10 \text{ V}; T_A = 25 \text{ }^\circ\text{C}$

Parameter	Symbol	Limit Values			Unit	Test Condition	Test Circuit
		min.	typ.	max.			
Analog values apply for feeding in on pins 2, 3, 25 and 26.							
Distortion	THD_{13} THD_{14} THD_{15} THD_{16}		0.01	0.1	%	$V_1 = 300 \text{ mVrms}$ 02,2F; 03,6F; Vol. 47 $V_{28} = 300 \text{ mVrms}$ 02,2F; 03,6F; Vol. 47	1
Distortion	THD_{13} THD_{14} THD_{15} THD_{16}		0.05	0.2	%	$V_1 = 150 \text{ mVrms}$ 04,XX any tone setting $V_{28} = 150 \text{ mVrms}$ 04,XX any tone setting	1
Unweighted signal/noise ratio	a_S/N_{13} a_S/N_{14} a_S/N_{15} a_S/N_{16}		105		dB	V_{Nrms} 20 Hz ... 20 kHz $V_1 = 2 \text{ Vrms}$ V_{Nrms} 20 Hz ... 20 kHz $V_{28} = 2 \text{ Vrms}$	1
Unweighted signal/noise ratio	a_S/N_{13} a_S/N_{14} a_S/N_{15} a_S/N_{16}		60		dB	V_{Nrms} 20 Hz ... 20 kHz $V_1 = 0.3 \text{ Vrms}$ 02,27; 03,67 Vol. 39 V_{Nrms} 20 Hz ... 20 kHz $V_{28} = 0.3 \text{ Vrms}$ 02,27; 03,67 Vol. 39	1
Unweighted noise voltage	V_{N13} V_{N14} V_{N15} V_{N16}			20	μVrms	V_{Nrms} 20 Hz ... 20 kHz 02,00; 03,00 Vol. 0	1
Bridge power-amp	Φ_{13-14}		180			Bit Ph = '0'	1
Modus	Φ_{15-16}		180			Bit Ph = '0'	1
Load resistor	$R_{L13, 14}$	4.5			$k\Omega$	$V_{13, 14} = 2.5 \text{ V};$ $THD < 1 \%$ $V_{15, 16} = 2.5 \text{ V};$ $THD < 1 \%$	1
	$R_{L15, 16}$ $R_{L13, 14}$ $R_{L15, 16}$	1.5			$k\Omega$	Bit fan = '1' $V_{13, 14} = 2.5 \text{ V};$ $THD < 1 \%$ Bit fan = '1' $V_{15, 16} = 2.5 \text{ V};$ $THD < 1 \%$	1
DC jump $\Delta 1$ bit	ΔV_{13}			± 4	mV	Sub, X-Sub, X ± 1	1

3.3 AC/DC Characteristics (cont'd)

$V_{10} = 10\text{ V}; T_A = 25\text{ °C}$

Parameter	Symbol	Limit Values			Unit	Test Condition	Test Circuit
		min.	typ.	max.			
Analog values apply for measuring on pins 14, 15 and 16.							
DC jump $\Delta 1$ bit	ΔV_{13}			± 6	mV	01, 03-01, 04-01, 05-01, 06-01, 07 <i>Input level control</i>	1
DC jump $\Delta 1$ bit	ΔV_{13}			± 10	mV	01, 07-01, 08-01, 09-01, 0A-01, 08 <i>Input level control</i>	1
PSRR Power supply Ripple rejection	a_{PSRR13}		70		dB	$V_{i,interf} = 1\text{ Vrms}$ $f_{i,interf} = 100\text{ Hz} \dots 20\text{ kHz}$ $R_G = 220\ \Omega$ Measurement CCIR 651 Effective	1
	a_{PSRR14}		70		dB		1
	a_{PSRR15}		70		dB		1
	a_{PSRR16}		70		dB		1
Zero crossing detector window			± 30		mV		1
Mute active	V_{QML}	0.3		1.5	V		1
Mute inactive	V_{QMH}	3		5.5	V		1
Input current	I_{OH}			50	μA		1
	I_{OL}			100	μA		1

Design Hints

Input resistance	R_1	30			$\text{k}\Omega$		
	R_2						
	R_3						
	R_{25}						
	R_{26}						
	R_{28}						
Output resistance	R_{13}			70	Ω		
	R_{14}						
	R_{15}						
	R_{16}						

3.3 AC/DC Characteristics (cont'd)

$V_{10} = 10 \text{ V}; T_A = 25 \text{ }^\circ\text{C}$

Parameter	Symbol	Limit Values			Unit	Test Condition	Test Circuit
		min.	typ.	max.			

I²C Bus (SCL, SDA)

SCL, SDA Edges

Rise time	t_R			1	μs		
Fall time	t_F			300	ns		

Shift Register Clock Pulse SCL

Frequency	f_{SCL}	0		100	kHz		
H pulse width	t_{High}	4			μs		
L pulse width	t_{Low}	4			μs		

Start

Set-up time	t_{SUSTA}	4			μs		
Hold time	t_{HDSTA}	4			μs		

Stop

Set-up time	t_{SUSTO}	4			μs		
Bus free time	t_{BUF}	4			μs		

Data Transfer

Set-up time	t_{SUDAT}	250			ns		
Hold time	t_{HDDAT}	1			μs		

Input SCL, SDA

Input voltage	V_{QH}	3		5.5	V		1
	V_{QL}			1.5			
Input current	I_{OH}	3		50	μA		1
	I_{OL}			100	μA		

3.3 AC/DC Characteristics (cont'd)

$V_{10} = 10 \text{ V}; T_A = 25 \text{ }^\circ\text{C}$

Parameter	Symbol	Limit Values			Unit	Test Condition	Test Circuit
		min.	typ.	max.			

Output SDA (open collector)

Output voltage	V_{OH}	5.5			V	$R_L = 2.5 \text{ k}\Omega$	1
	V_{OL}			0.4		$I_{OL} = 3 \text{ mA}$	

Note: The listed characteristics are ensured over the operating range of the integrated circuit. Typical characteristics specify mean values expected over the production spread. If not otherwise specified, typical characteristics apply at $T_A = 25 \text{ }^\circ\text{C}$ and the given supply voltage.

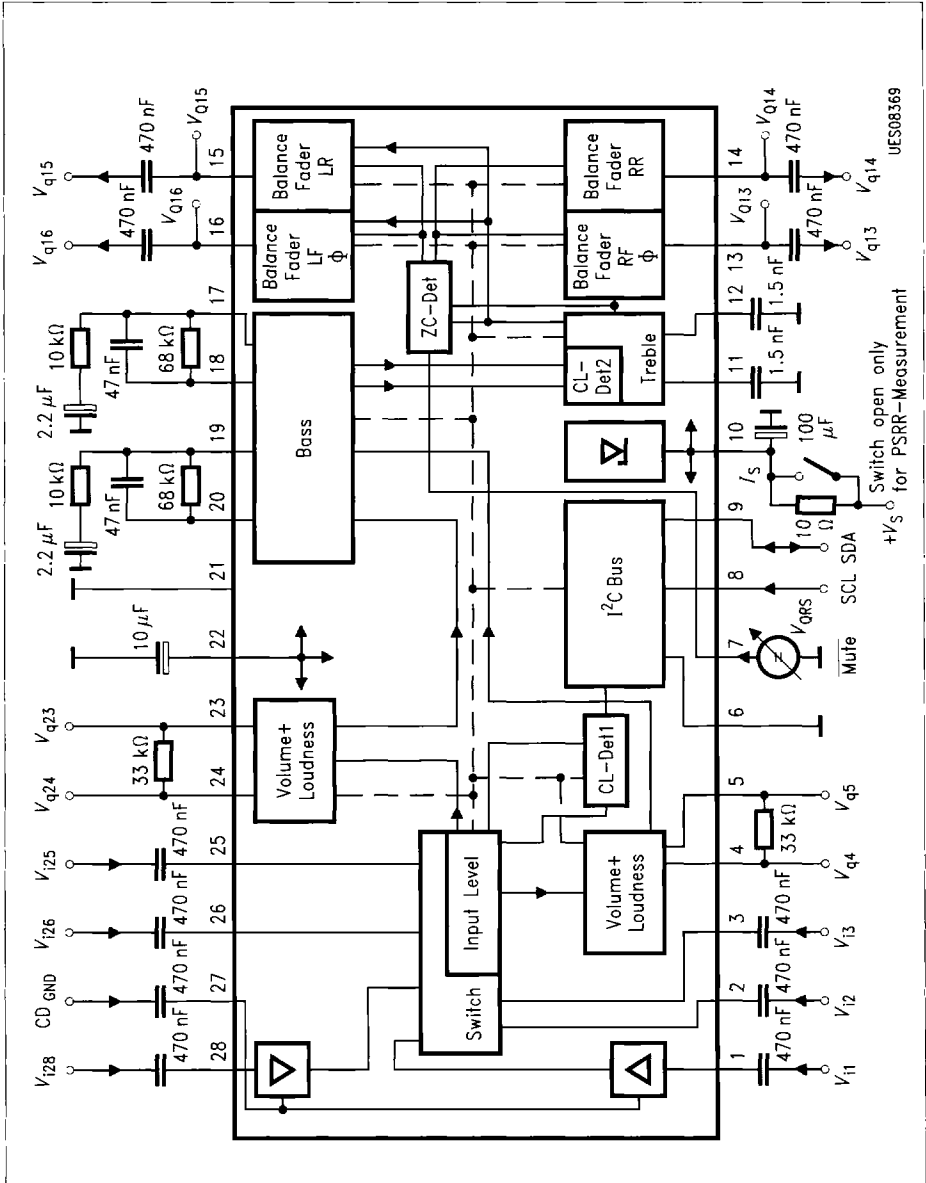

UES08369

Figure 15
Test Circuit

Application Circuit 2

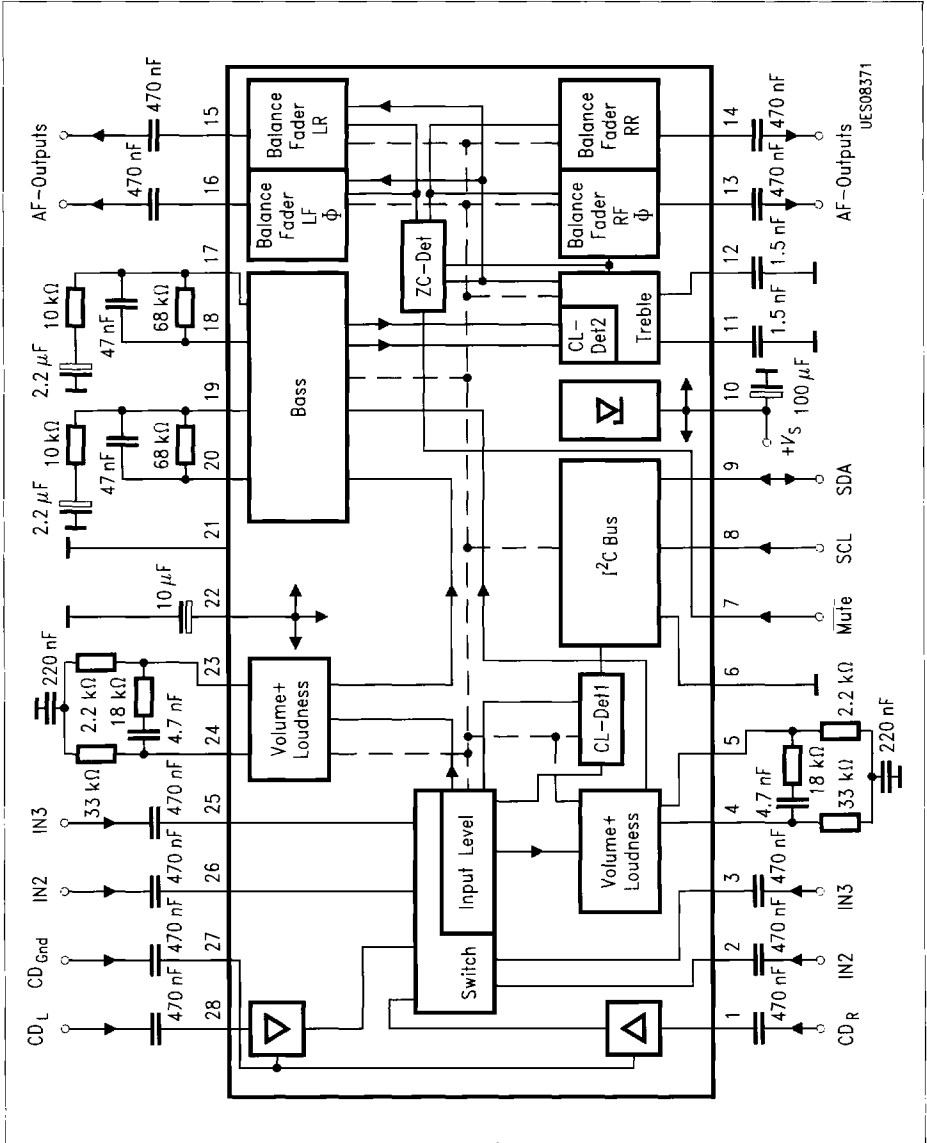

Figure 17
Bass/Treble Loudness Circuitry and 1. Order Bass Control Characteristic

Diagram

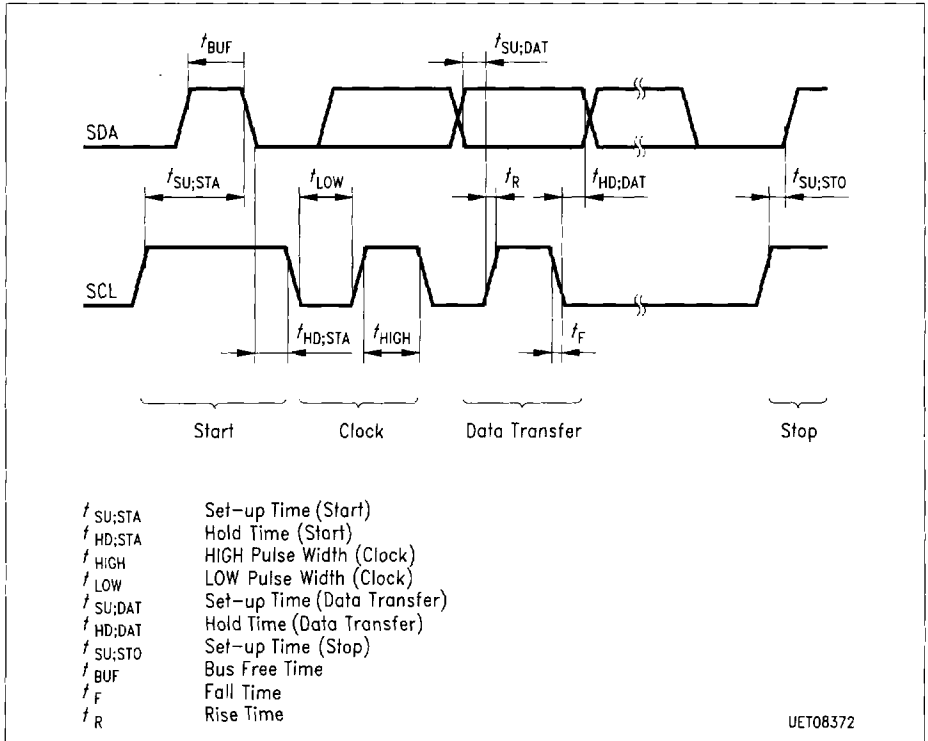
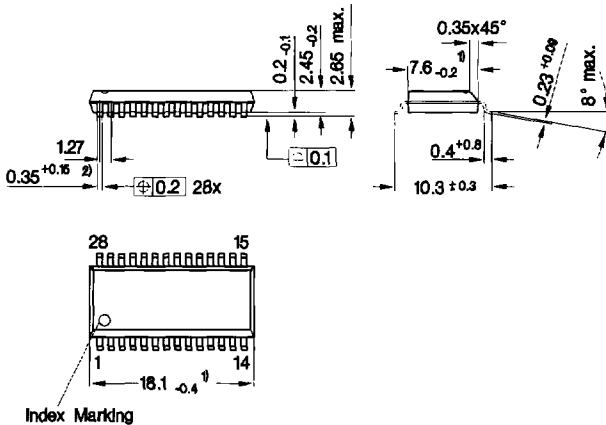

Figure 18
I²C Bus Timing

4 Package Outlines

P-DSO-28-1
(Plastic Dual Small Outline Package)



- 1) Does not include plastic or metal protrusion of 0.15 max. per side
- 2) Does not include dambar protrusion

GPS05123

Sorts of Packing

Package outlines for tubes, trays etc. are contained in our Data Book "Package Information".

SMD = Surface Mounted Device

Dimensions in mm