

Fast CMOS 18-Bit Registered Transceivers
Product Features:
Common Features:

- PI74FCT16501T and PI74FCT162501T have high current drive and three speed grades.
 "A" speeds at 5.1 ns max.
 "C" speeds at 4.6 ns max.
 "D" speeds at 4.1 ns max.
 "E" speeds at 3.8 ns max.
- $V_{CC} = 5\text{ V} \pm 10\%$
- Hysteresis on all inputs
- Packaged in 56-pin plastic TSSOP and SSOP

PI74FCT16501T Features:

- High output drive: $I_{OH} = -32\text{ mA}$; $I_{OL} = 64\text{ mA}$
- Power off disable outputs permit "live insertion"
- Typical V_{OLP} (Output Ground Bounce) $< 1.0\text{ V}$ at $V_{CC} = 5\text{ V}$, $T_A = 25^\circ\text{C}$

PI74FCT162501T Features:

- Balanced output drivers: $\pm 24\text{ mA}$
- Reduced system switching noise
- Typical V_{OLP} (Output Ground Bounce) $< 0.6\text{ V}$ at $V_{CC} = 5\text{ V}$, $T_A = 25^\circ\text{C}$

Product Description:

Pericom Semiconductor's PI74FCT series of logic circuits are produced in the Company's advanced 0.8 micron CMOS technology, achieving industry leading speed grades.

The PI74FCT16501T and PI74FCT162501T are 18-bit registered bus transceivers designed with D-type latches and flip-flops to allow data flow in transparent, latched, and clocked modes. The Output Enable (OEAB and OEBA, Latch Enable (LEAB and LEBA) and Clock (CLKAB and CLKBA) inputs control the data flow in each direction. When LEAB is HIGH, the device operates in transparent mode for A-to-B data flow. When LEAB is LOW, the A data is latched if CLKAB is held at a HIGH or LOW logic level. The A bus data is stored in the latch/flip-flop on the HIGH-to-LOW transition of CLKAB, if LEAB is LOW. OEAB performs the output enable function on the B port. Data flow from B port to A port is similar using OEBA, LEBA and CLKBA. These high-speed, low power devices offer a flow-through organization for ease of board layout.

The PI74FCT16501T output buffers are designed with a Power-Off disable allowing "live insertion" of boards when used as backplane drivers.

The PI74FCT162501T has $\pm 24\text{ mA}$ balanced output drivers. It is designed with current limiting resistors at its outputs to control the output edge rate resulting in lower ground bounce and undershoot. This eliminates the need for external terminating resistors for most interface applications.

All products are available in 56-pin 240 mil wide plastic TSSOP and 300 mil wide plastic SSOP packages.

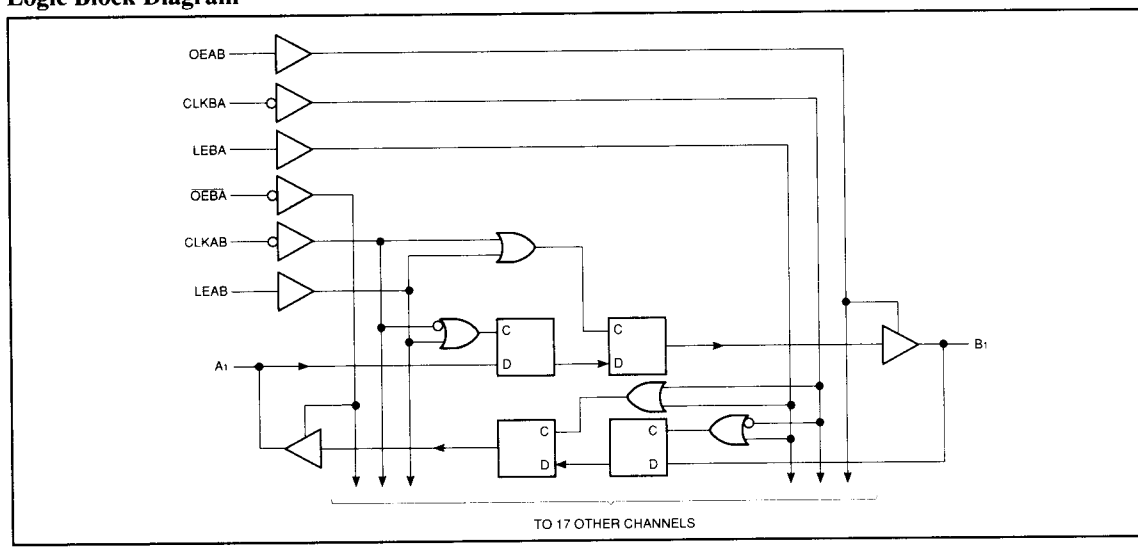
Logic Block Diagram

Product Pin Description

Pin Name	Description
OEAB	A-to-B Output Enable Input
\overline{OEBA}	B-to-A Output Enable Input (Active LOW)
LEAB	A-to-B Latch Enable Input
LEBA	B-to-A Latch Enable Input
CLKAB	A-to-B Clock Input
CLKBA	B-to-A Clock Input
Ax	A-to-B Data Inputs or B-to-A 3-State Outputs
Bx	B-to-A Data Inputs or A-to-B 3-State Outputs
GND	Ground
Vcc	Power

Truth Table^(1,4)

Inputs				Outputs
OEAB	LEAB	CLKAB	Ax	Bx
L	X	X	X	Z
H	H	X	L	L
H	H	X	H	H
H	L	↓	L	L
H	L	↓	H	H
H	L	H	X	B ⁽²⁾
H	L	L	X	B ⁽³⁾

NOTES:

1. A-to-B data flow is shown. B-to-A data flow is similar but uses OEBA, LEBA, and CLKBA.
2. Output level before the indicated steady-state input conditions were established.
3. Output level before the indicated steady-state input conditions were established, provided that CLKAB was LOW before LEAB went LOW.
4. H = High Voltage Level
L = Low Voltage Level
Z = High Impedance
↓ = HIGH-to-LOW Transition

Product Pin Configuration

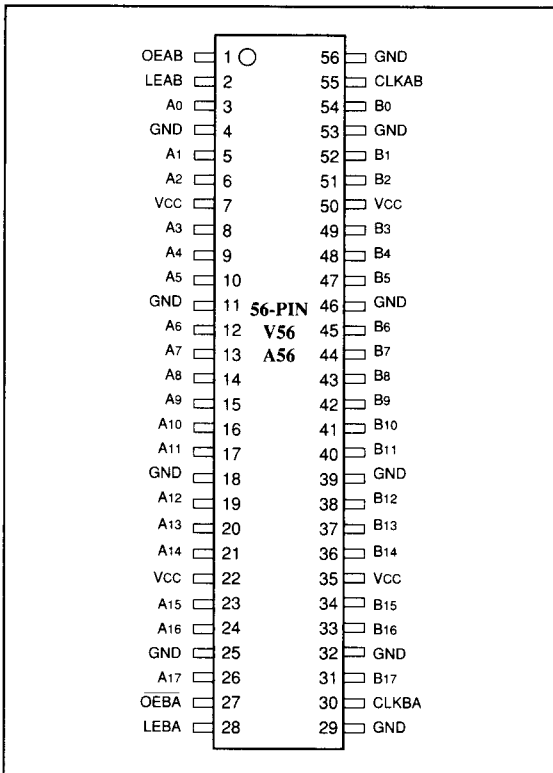



Maximum Ratings

(Above which the useful life may be impaired. For user guidelines, not tested.)

Storage Temperature	-55°C to +125°C
Ambient Temperature with Power Applied	-40°C to +85°C
Supply Voltage to Ground Potential (Inputs & Vcc Only)	-0.5V to +7.0V
Supply Voltage to Ground Potential (Outputs & D/O Only)	-0.5V to Vcc
DC Input Voltage	-0.5V to +7.0V
DC Output Current	120 mA
Power Dissipation	1.0W

Note:

Stresses greater than those listed under MAXIMUM RATINGS may cause permanent damage to the device. This is a stress rating only and functional operation of the device at these or any other conditions above those indicated in the operational sections of this specification is not implied. Exposure to absolute maximum rating conditions for extended periods may affect reliability.

DC Electrical Characteristics (Over the Operating Range, TA = -40°C to +85°C, VCC = 5.0V ± 10%)

Parameters	Description	Test Conditions ⁽¹⁾	Min.	Typ ⁽²⁾	Max.	Units
V _{IH}	Input HIGH Voltage	Guaranteed Logic HIGH Level	2.0			V
V _{IL}	Input LOW Voltage	Guaranteed Logic LOW Level			0.8	V
I _{IH}	Input HIGH Current	VCC = Max., VIN = VCC			±5	µA
I _{IL}	Input LOW Current	VCC = Max., VIN = GND			±5	µA
IOZH	High Impedance	VCC = Max., VOUT = 2.7 V			±10	µA
IOZL	Output Current	VCC = Max., VOUT = 0.5 V			±10	µA
V _{IK}	Clamp Diode Voltage	VCC = Min., IIN = -18 mA		-0.7	-1.2	V
IOS	Short Circuit Current	VCC = Max. ⁽³⁾ , VOUT = GND	-80	-140	-200	mA
IO	Output Drive Current	VCC = Max. ⁽³⁾ , VOUT = 2.5 V	-50		-180	mA
V _H	Input Hysteresis			100		mV

PI74FCT16501T Output Drive Characteristics (Over the Operating Range)

Parameters	Description	Test Conditions ⁽¹⁾	Min.	Typ ⁽²⁾	Max.	Units
VOH	Output HIGH Voltage	VCC = Min., VIN = VIH or VIL, IOH = -3.0 mA	2.5	3.5		V
		IOH = -15.0 mA	2.4	3.5		
		IOH = -32.0 mA	2.0	3.0		
VOL	Output LOW Voltage	VCC = Min., VIN = VIH or VIL, IOL = 64 mA		0.2	0.55	V
IOFF	Power Down Disable	VCC = 0 V, VIN or VOUT ≤ 4.5 V	—	—	±100	µA

PI74FCT162501T Output Drive Characteristics (Over the Operating Range)

Parameters	Description	Test Conditions ⁽¹⁾	Min.	Typ ⁽²⁾	Max.	Units
VOH	Output HIGH Voltage	VCC = Min., VIN = VIH or VIL, IOH = -24.0 mA	2.4	3.3		V
VOL	Output LOW Voltage	VCC = Min., VIN = VIH or VIL, IOL = 24 mA		0.3	0.55	V
I _{ODL}	Output LOW Current	VCC = 5 V, VIN = VIH or VIL, VOUT = 1.5 V ⁽³⁾	60	115	150	mA
I _{ODH}	Output HIGH Current	VCC = 5 V, VIN = VIH or VIL, VOUT = 1.5 V ⁽³⁾	-60	-115	-150	mA

Capacitance (TA = 25°C, f = 1 MHz)

Parameters ⁽⁴⁾	Description	Test Conditions	Typ	Max.	Units
C _{IN}	Input Capacitance	VIN = 0 V	4.5	6	pF
C _{OUT}	Output Capacitance	VOUT = 0 V	5.5	8	pF

Notes:

- For conditions show as Max. or Min., use appropriate value specified under Electrical Characteristics for the applicable device type.
- Typical values are at VCC = 5.0, +25°C ambient and maximum loading.
- Not more than one output should be shorted at one time. Duration of the test should not exceed one second.
- This parameter is determined by device characterization but is not production tested.

Power Supply Characteristics

Parameters	Description	Test Conditions ⁽¹⁾		Min.	Typ ⁽²⁾	Max.	Units
I _{CC}	Quiescent Power Supply Current	V _{CC} = Max.	V _{IN} = GND or V _{CC}		2	500	μA
ΔI _{CC}	Supply Current per Input @ TTL HIGH	V _{CC} = Max.	V _{IN} = 3.4 V ⁽³⁾		0.5	1.5	mA
I _{CCD}	Supply Current per Input per MHz ⁽⁴⁾	V _{CC} = Max., Outputs Open OEAB = OEBA = V _{CC} or GND One Bit Toggling 50% Duty Cycle	V _{IN} = V _{CC} V _{IN} = GND		75	120	μA/ MHz
I _C	Total Power Supply Current ⁽⁶⁾	V _{CC} = Max., Outputs Open f _{CP} = 10 MHz (CLKAB) 50% Duty Cycle OEAB = OEBA = V _{CC} LEAB = GND One Bit Toggling f _i = 5 MHz 50% Duty Cycle	V _{IN} = V _{CC} V _{IN} = GND		0.8	2.7 ⁽⁵⁾	mA
			V _{IN} = 3.4 V V _{IN} = GND		1.3	4.2 ⁽⁵⁾	
		V _{CC} = Max., Output Open f _{CP} = 10 MHz (CLKAB) 50% Duty Cycle OEAB = OEBA = V _{CC} LEAB = GND Eighteen Bits Toggling f _i = 2.5 MHz 50% Duty Cycle	V _{IN} = V _{CC} V _{IN} = GND		3.8	7.5 ⁽⁵⁾	
			V _{IN} = 3.4 V V _{IN} = GND		8.6	21.85 ⁽⁵⁾	

Notes:

- For conditions shown as Max. or Min., use appropriate value specified under Electrical Characteristics for the applicable device.
- Typical values are at V_{CC} = 5.0 V, +25°C ambient.
- Per TTL driven input (V_{IN} = 3.4 V); all other inputs at V_{CC} or GND.
- This parameter is not directly testable, but is derived for use in Total Power Supply Calculations.
- Values for these conditions are examples of the I_{CC} formula. These limits are guaranteed but not tested.

$$I_C = I_{CC} + \Delta I_{CC} + I_{CCD}$$

$$I_C = I_{CC} + \Delta I_{CC} \cdot D_H \cdot N_T + I_{CCD} (f_{CP}/2 + f_i N_i)$$

I_{CC} = Quiescent Current

ΔI_{CC} = Power Supply Current for a TTL High Input (V_{IN} = 3.4 V)

D_H = Duty Cycle for TTL Inputs High

N_T = Number of TTL Inputs at D_H

I_{CCD} = Dynamic Current Caused by an Input Transition Pair (HLH or LHL)

f_{CP} = Clock Frequency for Register Devices (Zero for Non-Register Devices)

f_i = Input Frequency

N_i = Number of Inputs at f_i

All currents are in milliamps and all frequencies are in megahertz.

PI74FCT16501T Switching Characteristics over Operating Range

Preliminary

Parameters	Description	Conditions ⁽¹⁾	FCT16501AT		FCT16501CT		FCT16501DT		FCT16501ET		Unit
			Com.		Com.		Com.		Com.		
			Min	Max	Min	Max	Min	Max	Min	Max	
t _{MAX}	CLKAB or CLKBA frequency	Cl = 50 pF	—	150	—	150	—	150	—	150	MHz
t _{PLH} t _{PHL}	Propagation Delay Ax to Bx or Ax to Bx	RL = 500 Ω	1.5	5.1	1.5	4.6	1.5	4.1	1.5	3.8	ns
t _{PLH} t _{PHL}	Propagation Delay LEBA to Ax, LEAB to Bx		1.5	5.6	1.5	5.3	1.5	4.6	1.5	4.2	ns
t _{PLH} t _{PHL}	Propagation Delay CLKBA to Ax, CLKAB to Bx		1.5	5.6	1.5	5.3	1.5	4.6	1.5	4.2	ns
t _{PZH} t _{PZL}	Output Enable Time OEBA to Ax, OEAB to Bx		1.5	6.0	1.5	5.6	1.5	5.0	1.5	4.8	ns
t _{PHZ} t _{PLZ}	Output Disable Time OEBA to Ax, OEAB to Bx		1.5	5.6	1.5	5.2	1.5	4.8	1.5	4.0	ns
t _{SU}	Setup Time HIGH or LOW Ax to CLKAB, Bx to CLKBA		3.0	—	3.0	—	3.0	—	2.4	—	ns
t _H	Hold Time HIGH or LOW Ax to CLKAB, Bx to CLKBA		0	—	0	—	0	—	0	—	ns
t _{SU}	Setup Time HIGH or LOW Ax to LEAB, Bx to LEBA	Clock HIGH	3.0	—	3.0	—	3.0	—	2.0	—	ns
		Clock LOW	1.5	—	1.5	—	1.5	—	1.5	—	ns
t _H	Hold Time HIGH or LOW Ax to LEAB, Bx to LEBA		1.5	—	1.5	—	1.5	—	0.5	—	ns
t _W	LEAB or LEBA Pulse Width HIGH ⁽³⁾		3.0	—	3.0	—	3.0	—	3.0	—	ns
t _W	CLKAB or CLKBA Pulse Width HIGH or LOW ⁽³⁾		3.0	—	3.0	—	3.0	—	3.0	—	ns
t _{SK(O)}	Output Skew ⁽⁴⁾		—	0.5	—	0.5	—	0.5	—	0.5	ns

Notes:

1. See test circuit and wave forms.
2. Minimum limits are guaranteed but not tested on Propagation Delays.
3. This parameter is guaranteed but not tested.
4. Skew between any two outputs, of the same package, switching in the same direction. This parameter is guaranteed by design.

PI74FCT162501T Switching Characteristics over Operating Range

Preliminary

Parameters	Description	Conditions ⁽¹⁾	Preliminary								Unit
			FCT162501AT		FCT162501CT		FCT162501DT		FCT162501ET		
			Com.		Com.		Com.		Com.		
			Min	Max	Min	Max	Min	Max	Min	Max	
t _{MAX}	CLKAB or CLKBA frequency	C _L = 50 pF	—	150	—	150	—	150	—	150	MHz
t _{PLH} t _{PHL}	Propagation Delay Ax to Bx or Ax to Bx	R _L = 500 Ω	1.5	5.1	1.5	4.6	1.5	4.1	1.5	3.8	ns
t _{PLH} t _{PHL}	Propagation Delay LEBA to Ax, LEAB to Bx		1.5	5.6	1.5	5.3	1.5	4.6	1.5	4.2	ns
t _{PLH} t _{PHL}	Propagation Delay CLKBA to Ax, CLKAB to Bx		1.5	5.6	1.5	5.3	1.5	4.6	1.5	4.2	ns
t _{PZH} t _{PZL}	Output Enable Time OEBA to Ax, OEAB to Bx		1.5	6.0	1.5	5.6	1.5	5.0	1.5	4.8	ns
t _{PHZ} t _{PLZ}	Output Disable Time OEBA to Ax, OEAB to Bx		1.5	5.6	1.5	5.2	1.5	4.8	1.5	4.0	ns
t _{SU}	Setup Time HIGH or LOW Ax to CLKAB, Bx to CLKBA		3.0	—	3.0	—	3.0	—	2.4	—	ns
t _H	Hold Time HIGH or LOW Ax to CLKAB, Bx to CLKBA		0	—	0	—	0	—	0	—	ns
t _{SU}	Setup Time HIGH or LOW Ax to LEAB, Bx to LEBA	Clock HIGH	3.0	—	3.0	—	3.0	—	2.0	—	ns
		Clock LOW	1.5	—	1.5	—	1.5	—	1.5	—	ns
t _H	Hold Time HIGH or LOW Ax to LEAB, Bx to LEBA		1.5	—	1.5	—	1.5	—	0.5	—	ns
t _w	LEAB or LEBA Pulse Width HIGH ⁽³⁾		3.0	—	3.0	—	3.0	—	3.0	—	ns
t _w	CLKAB or CLKBA Pulse Width HIGH of LOW ⁽³⁾		3.0	—	3.0	—	3.0	—	3.0	—	ns
t _{SK(O)}	Output Skew ⁽⁴⁾		—	0.5	—	0.5	—	0.5	—	0.5	ns

Notes:

1. See test circuit and wave forms.
2. Minimum limits are guaranteed but not tested on Propagation Delays.
3. This parameter is guaranteed but not tested.
4. Skew between any two outputs, of the same package, switching in the same direction. This parameter is guaranteed by design.