

DASH NO.	M CODE	MADE FROM
----------	--------	-----------

GSD

1525-3-9

REVISIONS

ISSUE	CHANGES
0	ER 36357 ME 06/07/95
1	CN 36957 D KH 05/10/96
2	CN 38206 C BDH 02/06/01

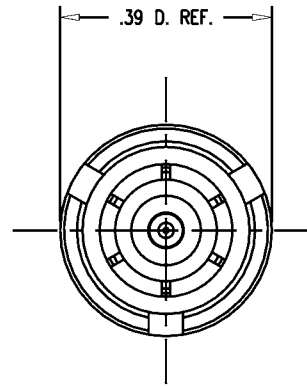
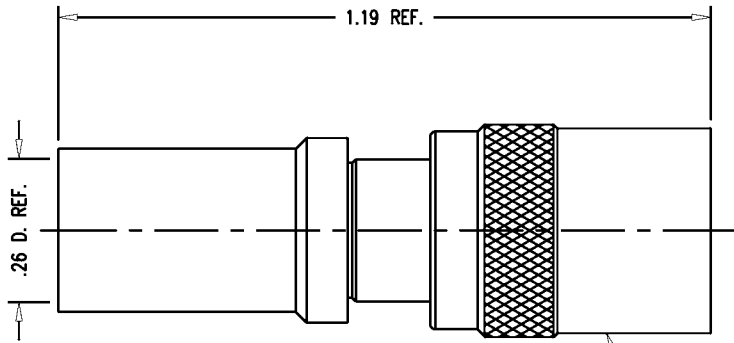

STAMP: 91836 1525-3-9
YRWK (DATE CODE)

NOTES:

- FOR USE WITH BOEING S280W503-3 AND ADAMS RUSSELL FC20Z CABLES.
- FOR CABLING INSTRUCTIONS SEE 3-546-1.
- FOR CRIMPING USE DIE KTH-2242.
- CONTACT P/N 1-7588-1MA9 TO BE SUPPLIED UNASSEMBLED.
- MARK PACKAGE: HS5982-1
1525-3-9
91836
YRWK (DATE CODE)
- MATERIALS:
GASKET: SIL. RUBBER, ZZ-R-765
INSULATOR: TEFLON, ASTM-D-4894
SPRING: STAINLESS STEEL WIRE
OUTER CONTACT: BER. COPPER, ASTM-B-196
ALL OTHER PARTS: BRASS, ASTM-B16
- FINISHES:
CENTER CONTACT: GOLD PLATE PER, MIL-G-45204
ALL OTHER METAL PARTS: KINGS TARNISH RESISTANT NICKEL FINISH (TR-5)
- ELECTRICAL CHARACTERISTICS:
NOMINAL IMPEDANCE: 50Ω
FREQUENCY RANGE: DC TO 10 GHz
VOLTAGE RATING: 500 VOLTS RMS

QGS0505

SCALE 4:1

APPROX SURFACE AREA

WAS: E-18859

USED ON

REF: Mc D. DOUGLAS #HS5982-1 REV. -

PL, TPS

DRAWN	ME	DATE	06/05/95
-------	----	------	----------

DESIGN	AR	DATE	06/05/95
--------	----	------	----------

APPR.		DATE	
-------	--	------	--

KINGS
ELECTRONICS CO., INC.
ROCK HILL, SOUTH CAROLINA 29730

GSD

1525-3-9