

2–18 GHz Low Noise Gallium Arsenide FET

Technical Data

ATF-13100

Features

- **Low Noise Figure:**
1.1 dB Typical at 12 GHz
- **High Associated Gain:**
9.5 dB Typical at 12 GHz
- **High Output Power:**
17.5 dBm Typical $P_{1\text{ dB}}$ at 12 GHz

Description

The ATF-13100 is a high performance gallium arsenide Schottky-barrier-gate field effect transistor chip. This device is designed for use in low noise, wideband amplifier and oscillator applications in the 2-18 GHz frequency range.

This GaAs FET device has a nominal 0.3 micron gate length with a total gate periphery of 250 microns. Proven gold based metallization systems and nitride passivation assure a rugged, reliable device.

The recommended mounting procedure is to die attach at a stage temperature of 300°C using a gold-tin preform under forming gas. Assembly can be preformed with either wedge or ball bonding using 0.7 mil gold wire. See also “Chip Use” in the APPLICATIONS section.

Chip Outline

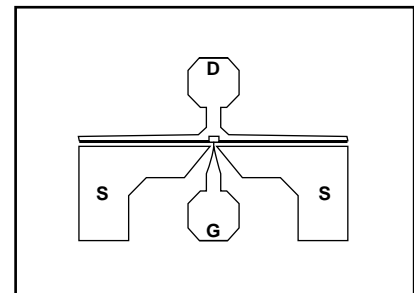

Electrical Specifications, $T_A = 25^\circ\text{C}$

Symbol	Parameters and Test Conditions ^[1]	Units	Min.	Typ.	Max.	
NF _O	Optimum Noise Figure; $V_{DS} = 2.5\text{ V}$, $I_{DS} = 20\text{ mA}$	$f = 8.0\text{ GHz}$	dB		0.8	1.2
		$f = 12.0\text{ GHz}$	dB		1.1	
		$f = 15.0\text{ GHz}$	dB		1.5	
G _A	Gain @ NF _O ; $V_{DS} = 2.5\text{ V}$, $I_{DS} = 20\text{ mA}$	$f = 8.0\text{ GHz}$	dB	9.0	12.0	
		$f = 12.0\text{ GHz}$	dB		9.5	
		$f = 15.0\text{ GHz}$	dB		8.0	
P _{1 dB}	Power Output @ 1 dB Gain Compression $V_{DS} = 4\text{ V}$, $I_{DS} = 40\text{ mA}$	$f = 12.0\text{ GHz}$	dBm		17.5	
G _{1 dB}	1 dB Compressed Gain; $V_{DS} = 4\text{ V}$, $I_{DS} = 40\text{ mA}$	$f = 12.0\text{ GHz}$	dB		8.5	
g _m	Transconductance; $V_{DS} = 2.5\text{ V}$, $V_{GS} = 0\text{ V}$		mmho	30	55	
I _{DSS}	Saturated Drain Current; $V_{DS} = 2.5\text{ V}$, $V_{GS} = 0\text{ V}$		mA	40	50	90
V _P	Pinchoff Voltage; $V_{DS} = 2.5\text{ V}$, $I_{DS} = 1\text{ mA}$		V	-3.0	-1.5	-0.8

Note:

1. RF performance is determined by assembling and testing 10 samples per wafer.

ATF-13100 Absolute Maximum Ratings

Symbol	Parameter	Units	Absolute Maximum ^[1]
V_{DS}	Drain-Source Voltage	V	+5
V_{GS}	Gate-Source Voltage	V	-4
V_{GD}	Gate-Drain Voltage	V	-6
I_{DS}	Drain Current	mA	I_{DSS}
P_T	Power Dissipation ^[2,3]	mW	225
T_{CH}	Channel Temperature	°C	175
T_{STG}	Storage Temperature	°C	-65 to +175

Thermal Resistance: $\theta_{jc} = 250^\circ\text{C/W}$; $T_{CH} = 150^\circ\text{C}$
Liquid Crystal Measurement: $1\ \mu\text{m}$ Spot Size^[4]

Notes:

1. Permanent damage may occur if any of these limits are exceeded.
2. $T_{\text{MOUNTING SURFACE}} = 25^\circ\text{C}$.
3. Derate at $4\ \text{mW}/^\circ\text{C}$ for $T_{\text{MOUNTING SURFACE}} > 119^\circ\text{C}$.
4. The small spot size of this technique results in a higher, though more accurate determination of θ_{jc} than do alternate methods. See MEASUREMENTS section for more information.

Part Number Ordering Information

Part Number	Devices Per Tray
ATF-13100-GP3	50

ATF-13100 Noise Parameters: $V_{DS} = 2.5\ \text{V}$, $I_{DS} = 20\ \text{mA}$

Freq. GHz	NF_0 dB	Γ_{opt}		$R_N/50$
		Mag	Ang	
4.0	0.4	0.60	30	0.32
6.0	0.7	0.32	68	0.21
8.0	0.8	0.25	102	0.15
12.0	1.1	0.23	-165	0.09
16.0	1.5	0.32	-112	0.21

ATF-13100 Typical Performance, $T_A = 25^\circ\text{C}$

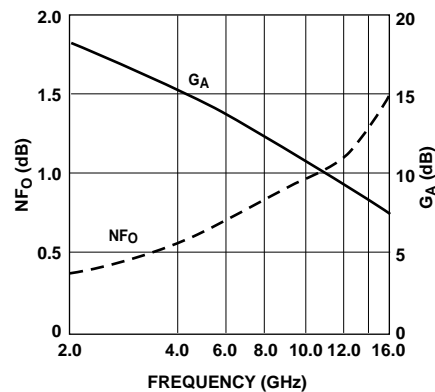

Figure 1. Optimum Noise Figure and Associated Gain vs. Frequency.
 $V_{DS} = 2.5\ \text{V}$, $I_{DS} = 20\ \text{mA}$, $T_A = 25^\circ\text{C}$.

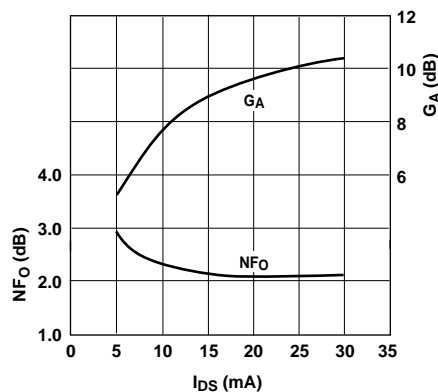
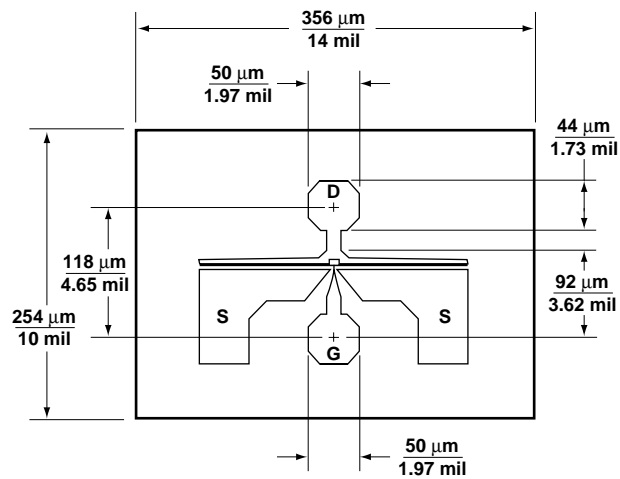

Figure 2. Optimum Noise Figure and Associated Gain vs. I_{DS} .
 $V_{DS} = 2.5\ \text{V}$, $f = 12.0\ \text{GHz}$.

Typical Scattering Parameters, Common Emitter, $Z_O = 50 \Omega$, $T_A = 25^\circ\text{C}$, $V_{DS} = 2.5 \text{ V}$, $I_{DS} = 20 \text{ mA}$

Freq. GHz	S_{11}		S_{21}			S_{12}			S_{22}	
	Mag.	Ang.	dB	Mag.	Ang.	dB	Mag.	Ang.	Mag.	Ang.
2.0	.96	-27	13.4	4.68	153	-26.9	.045	75	.55	-16
3.0	.92	-41	13.4	4.65	140	-23.6	.066	67	.52	-24
4.0	.85	-58	13.1	4.54	126	-21.4	.085	59	.49	-33
5.0	.79	-76	12.9	4.40	113	-19.8	.102	50	.44	-41
6.0	.73	-95	12.4	4.19	100	-18.7	.116	42	.38	-48
7.0	.68	-113	12.0	3.97	87	-18.0	.126	34	.30	-54
8.0	.63	-132	11.4	3.71	75	-17.5	.134	25	.24	-64
9.0	.62	-151	10.9	3.51	63	-17.1	.140	18	.18	-75
10.0	.59	-167	10.3	3.27	53	-16.8	.144	11	.13	-84
11.0	.59	173	9.7	3.07	40	-16.5	.149	2	.08	-104
12.0	.57	155	9.0	2.83	30	-16.5	.150	-9	.02	160
13.0	.60	136	8.6	2.69	19	-16.4	.151	-16	.08	106
14.0	.64	116	7.9	2.47	7	-16.4	.151	-25	.15	103
15.0	.67	98	7.1	2.26	-6	-16.4	.152	-34	.23	100
16.0	.73	83	5.8	1.96	-16	-16.9	.143	-40	.31	90
17.0	.77	72	4.6	1.70	-26	-17.0	.141	-45	.36	82
18.0	.80	63	3.5	1.50	-35	-17.4	.135	-48	.40	72

A model for this device is available in the DEVICE MODELS section.

ATF-13100 Chip Dimensions

Note: Die thickness is 4.5 mil, and backside metallization is 200 \AA Ti and 2000 \AA Au.



For technical assistance or the location of your nearest Hewlett-Packard sales office, distributor or representative call:

Americas/Canada: 1-800-235-0312 or 408-654-8675

Far East/Australasia: Call your local HP sales office.

Japan: (81 3) 3335-8152

Europe: Call your local HP sales office.

Data subject to change.
Copyright © 1997 Hewlett-Packard Co.

Printed in U.S.A. 5965-8694E (9/97)